

Pos.	Artikel-Nr.	PG	Bezeichnung	Stk.
9	346181-9	5	DRUCKFEDER 50	1
10	266349-0	4	VIERKANTSCHRAUBE M8x50	1
11	451539-0	5	GRIFFHALTER	1
12	313179-1	1	RACK	1
13	451540-5	1	VERRIEGELUNGSKNOPF	1
14	233360-7	1	DRUCKFEDER 4	1
15	154935-8	14	SEITENGRIF 36	1
16	140423-1	26	GETRIEBEGEHAEUSE	1
16,1	213345-9	13	O-RING 25	1
16,2	816445-0	1	HINWEISSCHILD	1
17	331890-3	8	HUELSE	1
18	211294-4	18	RILLENKUGELLAGER 6806LLU	1
19	232152-1	7	BLATTFEDER	1
20	325785-0	1	UMSCHALTSTIFT	1
21	234147-0	1	DRUCKFEDER 5	1
22	253308-3	2	SCHEIBE 6	1
23	213381-5	7	O-RING 21	1
24	451529-3	8	BETRIEBSARTENWAHLSCHALTER	1
25	451530-8	10	ABDECKUNG	1
27	216019-1	1	KUGEL 3	4
28	140266-1	35	ZYLINDER	1
29	313149-0	6	KUPPLUNGSSCHEIBE	1
30	227232-6	9	STIRNRAD 51	1
31	268226-2	11	STIFT 6	6
32	267414-8	1	SCHEIBE 30	1
33	234148-8	5	DRUCKFEDER 31	1
34	267153-0	1	SCHEIBE 30	1
35	257932-4	9	SICHERUNGSSCHEIBE 30	1
36	267153-0	1	SCHEIBE 30	1
37	325783-4	6	HUELSE 9B	1
38	325791-5	22	SCHLAGBOLZEN	1
39	325792-3	2	SCHEIBE 10	1
40	234149-6	1	DRUCKFEDER 20	1
41	325793-1	7	O-RING-GEHAEUSE	1
42	213073-6	3	O-RING 9	1
43	233979-2	1	SPRENGRING 28	1
44	325784-2	12	SCHLAEGER	1
45	213258-4	8	O-RING 17,5	1
46	310345-1	22	KOLBEN	1
47	346036-8	1	FUEHRUNGSPLATTE	1
48	324215-8	7	STIFT	1
49	234098-7	3	DRUCKFEDER 14	1
50	211012-0	21	RILLENKUGELLAGER 606ZZ	1
51	961012-7	2	SICHERUNGSSCHEIBE E-6	1
52	267449-9	1	SCHEIBE 7	1
53	233360-7	1	DRUCKFEDER 4	1
54	346176-2	1	VERRIEGELUNGSPLATTE	1

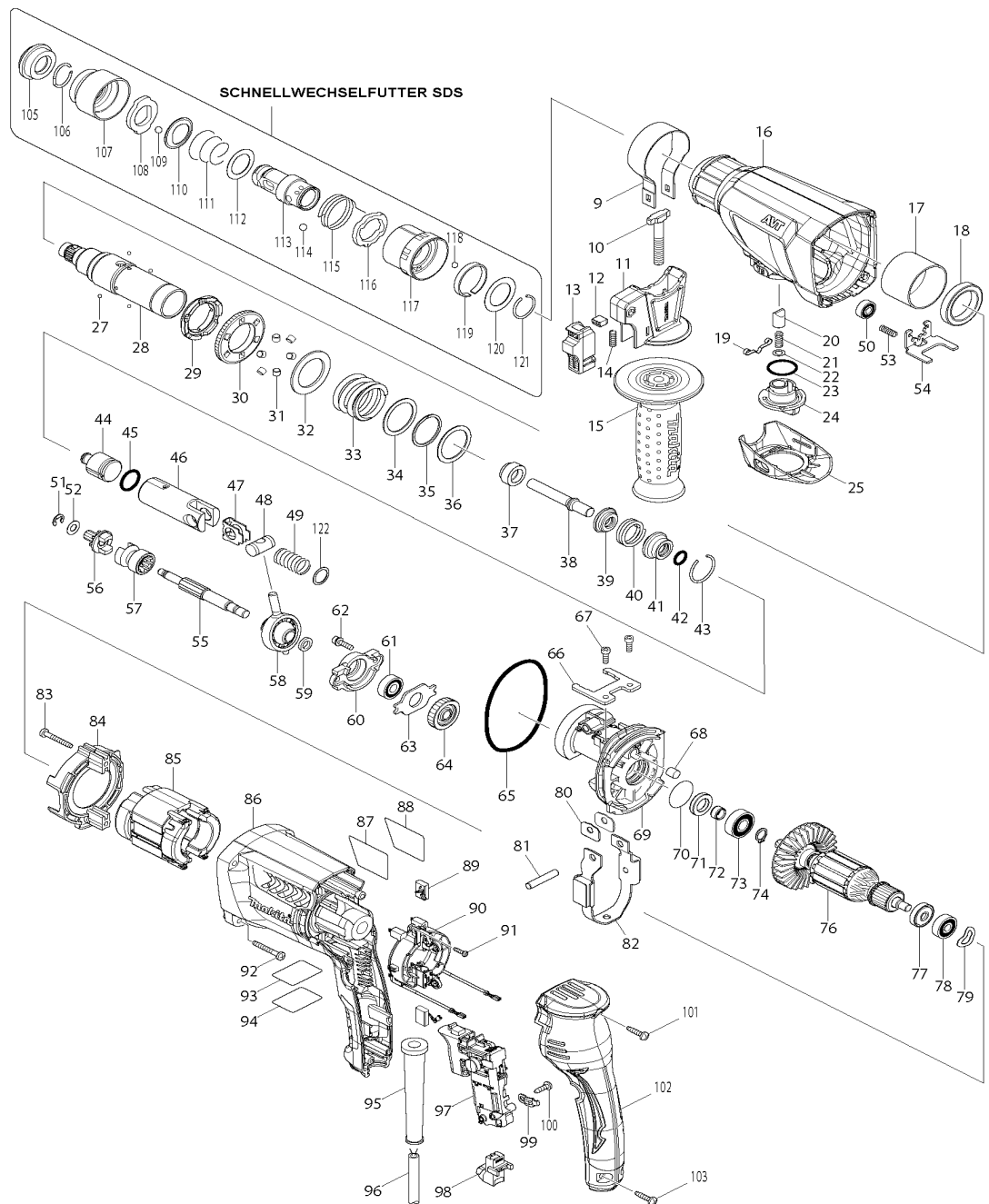

Pos.	Artikel-Nr.	PG	Bezeichnung	Stk.
55	325786-8	21	ZAHNWELLE	1
56	227231-8	25	STIRNRAD 10	1
57	331814-9	16	KUPPLUNGSHUELSE A	1
58	219020-5	31	PENDELLAGER 10	1
59	267234-0	1	SCHEIBE 8	1
60	310344-3	6	LAGERGEHAEUSE	1
61	211032-4	18	RILLENKUGELLAGER 608ZZ	1
62	266437-3	2	INNENSECHSKANTSCHRAUBE M4x16	2
63	285735-6	1	LAGERABDECKUNG	1
64	227719-8	15	STIRNRAD 26	1
65	213728-3	5	O-RING 68	1
66	346222-1	1	PLATTE	1
67	265353-6	1	INNENSECHSKANTSCHRAUBE M4x12	2
68	443153-6	1	FILZ	1
69	140267-9	19	LAGERGEHAEUSE	1
70	213407-3	3	O-RING 26	1
71	213133-4	18	DICHTRING 12	1
72	262569-4	1	HUELSE 9	1
73	211097-6	14	RILLENKUGELLAGER 6000LLB	1
74	961006-2	1	SICHERUNGSRING S-10	1
76	515359-7	34	ANKER INKL. 72-74, 77, 78	1
77	681652-2	2	ISOLIERSCHEIBE	1
78	210023-2	12	RILLENKUGELLAGER 627DDW	1
79	267804-5	1	WELLENSCHEIBE 15	1
80	346180-1	1	FUEHRUNGSPLATTE	2
81	256246-8	1	STIFT 6	1
82	165593-5	16	KONTERGEWICHT	1
83	266361-0	1	BLECHSCHRAUBE 4x30	2
84	451527-7	1	FELDABDECKUNG	1
85	626634-7	28	FELD	1
86	451535-8	27	MOTORGEHAEUSE	1
87	867747-7	1	TYPENSCHILD HR2611FT	1
88	819390-8	1	SCHUTZFOLIE	1
89	194074-2	13	KOHLEBUERSTEN CB-325	1
90	638655-7	20	BUERSTENBRUECKE	1
91	266556-5	1	BLECHSCHRAUBE 3x12	2
92	266361-0	1	BLECHSCHRAUBE 4x30	4
93	867751-6	1	SERIEN-NR.-SCHILD HR2611FT	1
94	819389-3	1	SCHUTZFOLIE	1
95	682566-8	6	KNICKSCHUTZ	1
96	665890-4	23	ANSCHLUSSLEITUNG H07RN-F	1
97	650625-6	27	ELEKTRONIKSCHALTER	1
98	631937-6	23	LED-BAUSTEIN	1
99	687682-1	2	KABELKLEMMPLATTE	1
100	266385-6	1	BLECHSCHRAUBE 4x14	1
101	266326-2	1	SCHRAUBE 4x18	1
102	451528-5	18	HANDGRIFFDECKEL	1

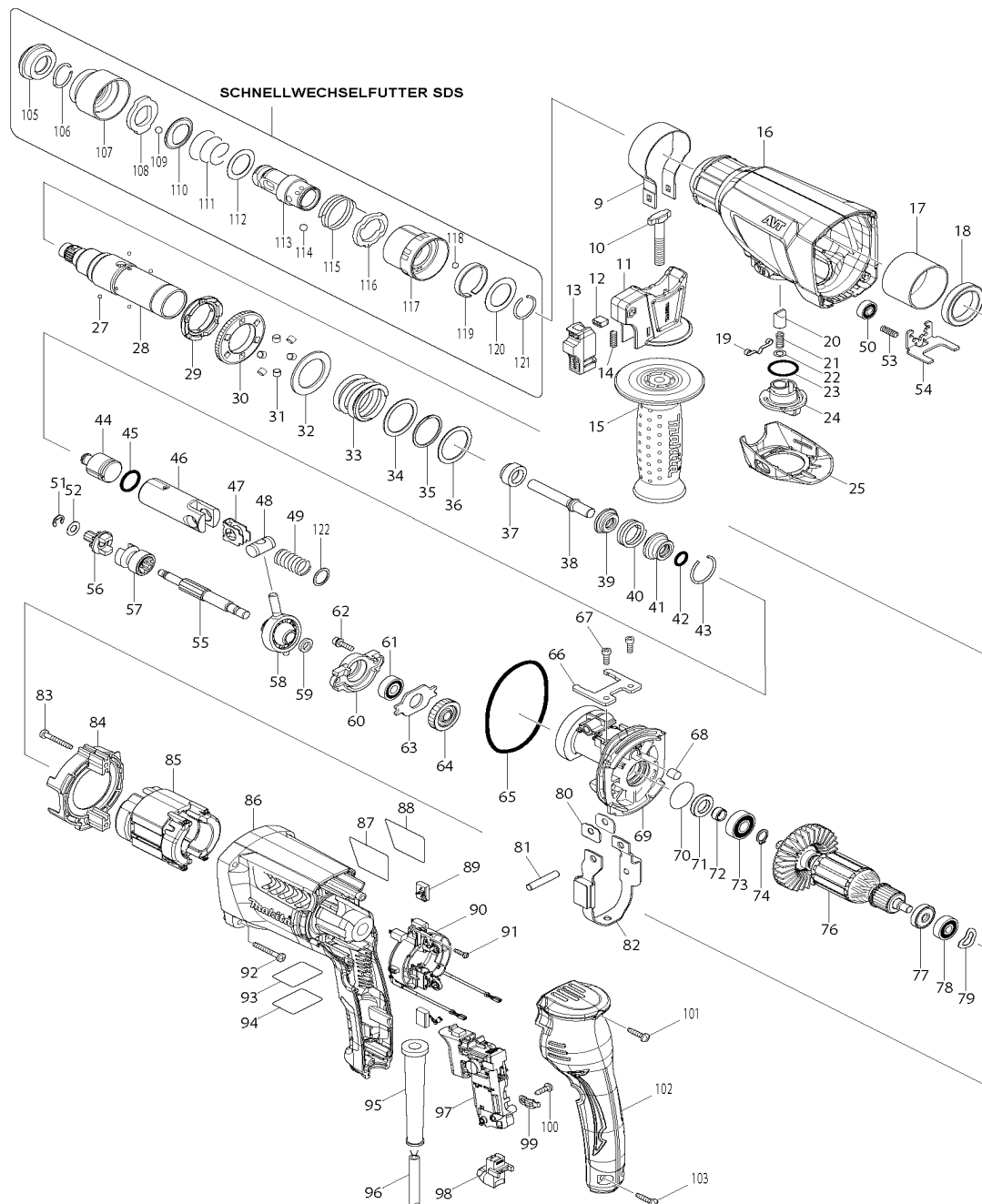

Pos.	Artikel-Nr.	PG	Bezeichnung	Stk.
103	266326-2	1	SCHRAUBE 4x18	2
105	286263-4	3	STAUBSCHUTZ 35	1
106	233940-9	1	SPRENGRING 19	1
107	418217-5	4	SCHUTZABDECKUNG	1
108	345333-9	3	STOPPER	1
109	216022-2	1	KUGEL 7,0	1
110	345187-4	2	FUEHRUNGSSCHEIBE	1
111	233916-6	1	SPIRALFEDER 21-29	1
112	267279-8	1	SCHEIBE 21	1
113	324355-2	36	WERKZEUGHALTER	1
114	216013-3	2	KUGEL 6	2
115	231669-1	1	SPANNFEDER 31	1
116	345334-7	5	STELLRING	1
117	418218-3	4	VERRIEGELUNGSHUELSE	1
118	216018-3	1	KUGEL 5.0	1
119	345335-5	2	BLATTFEDER	1
120	267270-6	2	SCHEIBE 24	1
121	233924-7	1	SPRENGRING 21	1
122	267447-3	1	SCHEIBE 14	1

*** ZUBEHÖR ***

Z	194080-7	32	SCHNELLWECHSELFUTTER SDS	1
Z	122878-2		SEITENGRIF KPL.	1
Z	331886-4		TIEFENANSLAG	1
Z	140403-7		TRANSPORTKOFFER	1
Z	162302-3		KOFFERVERSCHLUSS	2
Z	451749-9	10	HANDGRIF FUER TRANSPORTKOFFER	1
Z	194079-2	55	SCHNELLWECHSELFUTTER	1