

Spare Parts List

2006-05

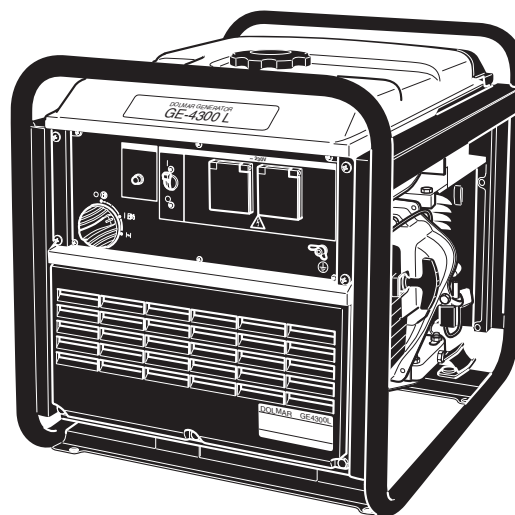

GE-4300 L

DOLMAR



A member of the *Makita* Group

995 700 279 (DE, GB, FR, ES)

DOLMAR GmbH

Postfach 70 04 20

D-22004 Hamburg

Germany

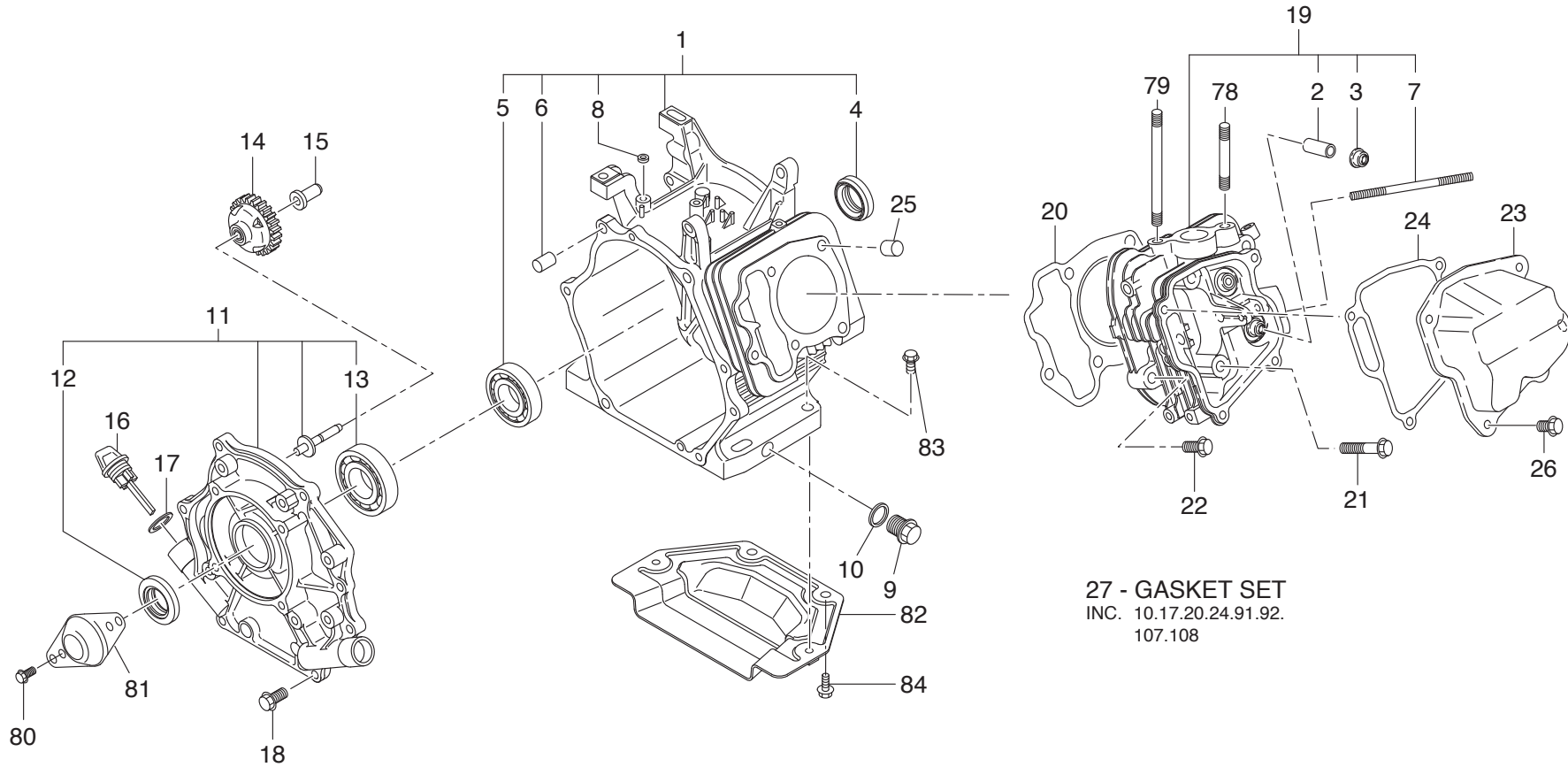

GE-4300 L



Seite / Page	Pos.	GE-4300 L	Teil-Nr. Part No. No. de pièce No. de pieza	Hinweise Notes Renseign. Nota	Bezeichnung	Spezifikation Specification	Description	Désignation	Denominación
1	1	1	368 101 027		KURBELGEHÄUSE KPL.		CRANKCASE CPL.	CARTER-VILEBREQUIN CPL.	CARTER CIGÜEÑAL CPL.
1	2	2	368 142 020		VENTILFÜHRUNG	5.5DX9.5DX27L	VALVE GUIDE	GUIDE-SOUPAPE	GUÍA VÁLVULA
1	3	1	368 160 100		DICHTUNG	5.5DX9.5DX15DX7.8B	GASKET	JOINT	JUNTA
1	4	1	368 030 016		RADIALDICHTRING	30DX45DX7B	OIL SEAL	JOINT RADIAL	JUNTA RADIAL
1	5	1	368 030 034		KUGELLAGER	30DX62DX16B	BALL BEARING	ROULEMENT A BILLES	RODAMIENTO DE BOLAS
1	6	2	368 150 110		ROHR	10.3DX8.5DX14L	PIPE KNOCK	TUBE	CONDUCTO
1	7	2	368 506 041		STIFTSCHRAUBE	M6X1.0X107L	STUD	GOUJON FILETÉ	PRISIONERO
1	8	1	381 006 002		RADIALDICHTRING	6DX10DX2.5B	OIL SEAL	JOINT RADIAL	JUNTA RADIAL
1	9	2	368 114 003		STOPFEN	M14X1.5X20DX12L	PLUG	BOUCHON	TAPON
1	10	2	368 114 002		DICHTUNG	14.1DX19DX2.3T	GASKET	JOINT	JUNTA
1	11	1	368 110 012		ABDECKUNG		COVER	COUVERCLE	CUBIERTA
1	12	1	368 030 016		RADIALDICHTRING	30DX45DX7B	OIL SEAL	JOINT RADIAL	JUNTA RADIAL
1	13	1	368 030 037		KUGELLAGER	30DX62DX16B	BALL BEARING	ROULEMENT A BILLES	RODAMIENTO DE BOLAS
1	14	1	368 450 041		REGLER KPL., GETRIEBE		GOVERNOR GEAR CPL.	RÉGULATEUR, TRANSMISSION CPL.	ENGRANAJE REGULADOR CPL.
1	15	1	381 419 010		REGLER, HÜLSE		GOVERNOR SLEEVE	RÉGULATEUR, DOUILLE	MANGUITO REGULADOR
1	16	2	381 636 011		ÖLPEILSTAB	M22X1.5 L=67.5+18	OIL GAUGE	GAUGE D'HUILE	INDICADOR DEL NIVEL DE ACEITE
1	17	2	368 320 005		DICHTUNG		GASKET	JOINT	JUNTA
1	18	7	368 040 835		BOLZEN		BOLT	BOULON	BULÓN
1	19	1	368 130 051		ZYLINDERKOPF KPL.		CYLINDER HEAD CPL.	CULASSE CPL.	CULATA CPL.
1	20	1	368 150 013		DICHTUNG	T=0.2	GASKET	JOINT	JUNTA
1	21	4	368 008 024		BOLZEN	M8X1.25X16DX68L	BOLT	BOULON	BULÓN
1	22	1	368 008 031		BOLZEN	M8X33L	BOLT	BOULON	BULÓN
1	23	1	368 155 030		ABDECKUNG F.KIPPHEBEL KPL.		ROCKER COVER CPL.	CAPOT POUR CULBUTEUR CPL.	TAPA DE BALANCINES CPL
1	24	1	368 160 011		DICHTUNG, ABDECKUNG F.KIPPHEBEL	T=0.5	GASKET, ROCKER COVER	JOINT, CAPOT POUR CULBUTEUR	JUNTA, TAPA DE BALANCINES CPL
1	25	2	368 150 110		ROHR	10.3DX8.5DX14L	PIPE KNOCK	TUBE	CONDUCTO
1	26	4	383 006 002		BOLZEN	M6X1.0X14DX12L	BOLT	BOULON	BULÓN
1	27	1	381 990 012		DICHTUNGEN, SATZ		GASKET, SET	JOINT, JEU	JUNTA, JUEGO
1	78	1	368 508 029		STIFTSCHRAUBE		STUD	GOUJON FILETÉ	PRISIONERO
1	79	1	368 508 044		STIFTSCHRAUBE	M8X120L	STUD	GOUJON FILETÉ	PRISIONERO
1	80	2	368 008 015		BOLZEN	M8X12L	BOLT	BOULON	BULÓN
1	81	1	368 870 010		ABDECKUNG		COVER	COUVERCLE	CUBIERTA
1	82	1	368 350 011		GRUNDPLATTE KPL.		BOTTOM PLATE CPL.	PLAQUE CPL.	PLACA CPL.
1	83	2	368 008 027		BOLZEN	M8X33L	BOLT	BOULON	BULÓN
1	84	2	368 008 015		BOLZEN	M8X12L	BOLT	BOULON	BULÓN

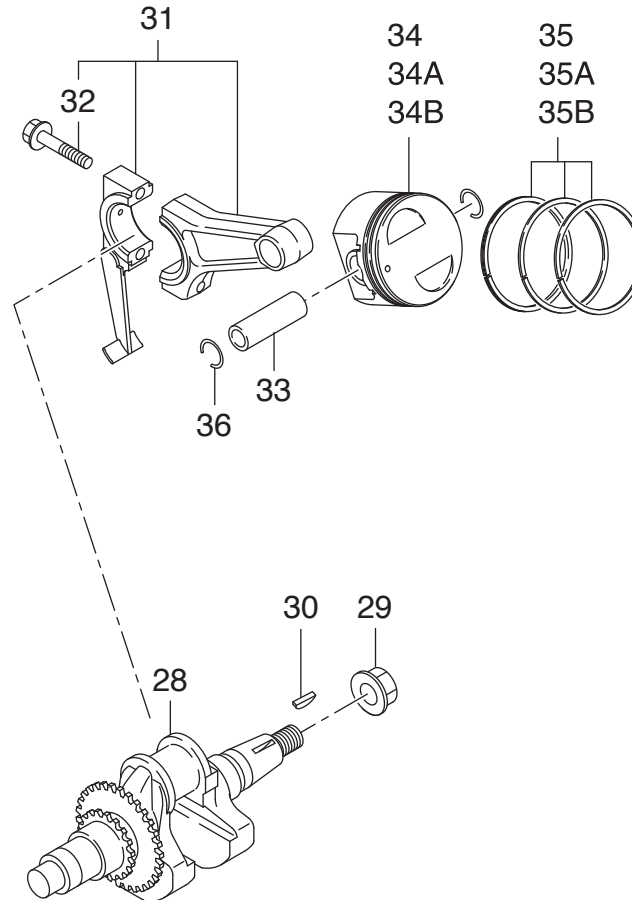

GE-4300 L



Seite / Page	Pos.	GE-4300 L	Teil-Nr. Part No. No. de pièce No. de pieza	Hinweise Notes Renseign. Nota	Bezeichnung	Spezifikation Specification	Description	Désignation	Denominación
2	28	1	368 205 010		KURBELWELLE KPL.		CRANKSHAFT CPL.	VILEBREQUIN CPL.	CIGÜEÑAL CPL.
2	29	1	368 018 001		MUTTER	M18X15X31DX14H	NUT	ECROU	TUERCA
2	30	1	368 303 001		SCHEIBENFEDER		WOODRUFF KEY	CLAVETTE	CHAVETA
2	31	1	368 225 012		PLEUELSTANGE KPL.		CONNECTING ROD ASSY.	BIELLE	BIELA
2	32	2	383 230 010		BOLZEN	M7X1.0X13.8DX40L	BOLT	BOULON	BULÓN
2	33	1	381 233 011		KOLBENBOLZEN	18DX13DX53L	PISTON PIN	AXE DE PISTON	PERNO DE PISTÓN
2	34	1	381 234 013		KOLBEN	STD (75DX43H)	PISTON	PISTON	PISTON
2	34A	1	383 234 033		KOLBEN		PISTON	PISTON	PISTON
2	34B	1	381 234 043		KOLBEN		PISTON	PISTON	PISTON
2	35	1	368 235 111		KOLBENRING-SATZ	STD(75D) OIL EXPAND	PISTON RING SET	JEU DE SEGMENTS DE PISTON	JUEGO DE SEGMENTOS DEL PISTÓN
2	35A	1	368 235 121		KOLBENRING-SATZ	0.25 OVER SIZE	PISTON RING SET	JEU DE SEGMENTS DE PISTON	JUEGO DE SEGMENTOS DEL PISTÓN
2	35B	1	368 235 131		KOLBENRING-SATZ	0.25 OVER SIZE	PISTON RING SET	JEU DE SEGMENTS DE PISTON	JUEGO DE SEGMENTOS DEL PISTÓN
2	36	2	368 518 001		SPRENGRING	18.9DX1.6D	CLIP	ANNEAU RESSORT	ANILLO ELÁSTICO

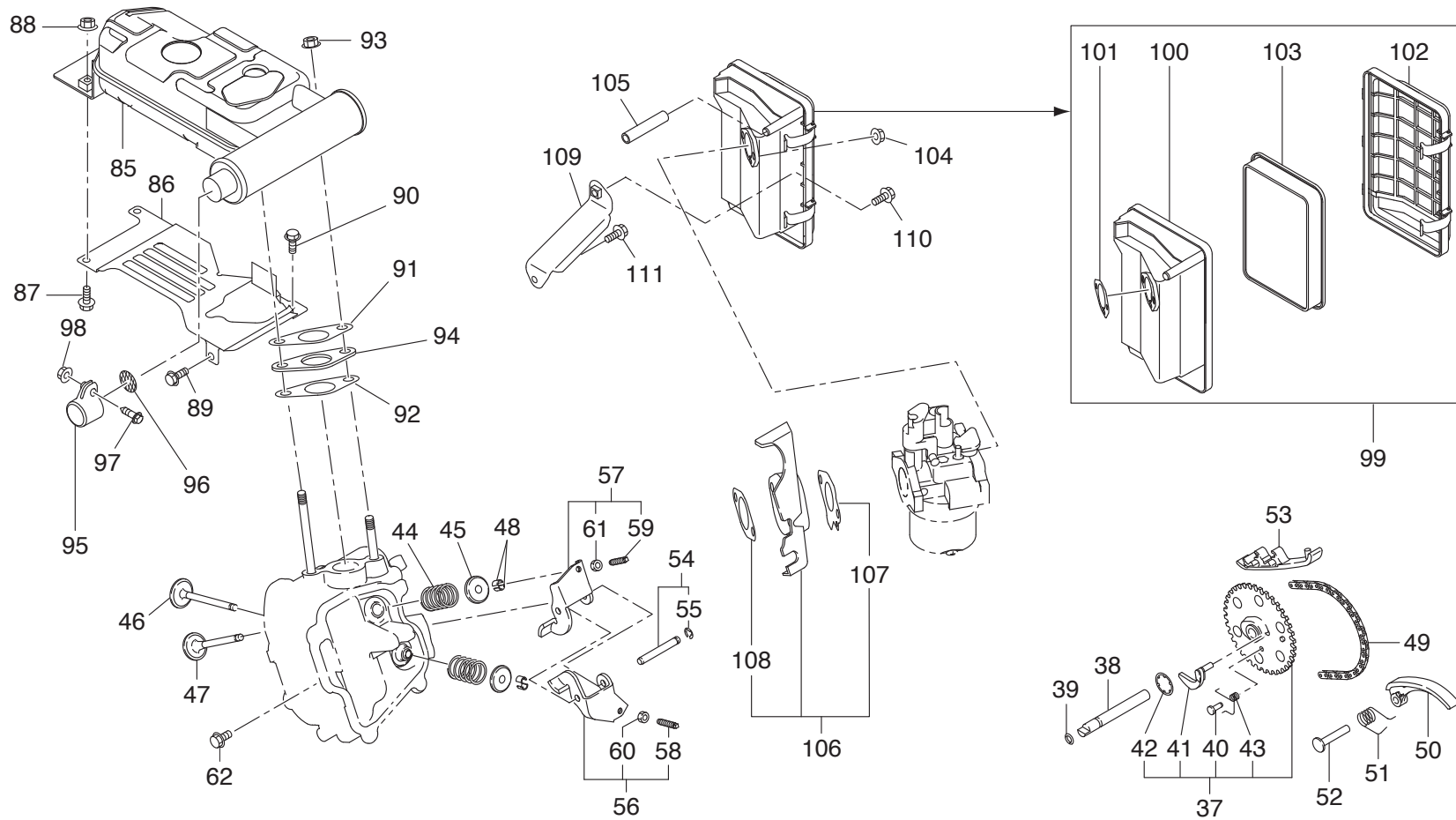

GE-4300 L



Seite / Page	Pos.	GE-4300 L	Teil-Nr. Part No. No. de pièce No. de pieza	Hinweise Notes Renseign. Nota	Bezeichnung	Spezifikation Specification	Description	Désignation	Denominación
3	37	1	368 316 021		ACHSE F.NOCKENRAD	93DX2.9B N=44	CAM GEAR SHAFT	AXE DE PIGNON DE DISTRIBUTION	EJE D. PIÑÓN D. ÁRB. DE LEV.
3	38	1	368 351 010		STIFT	9DX78.5L	PIN	GOUPILLE	PERNO
3	39	1	381 006 001		O-RING	5.8DX9.6D	O RING	ANNEAU TORIQUE	ANILLO OBTURADOR
3	40	1	368 386 010		STIFT	4DX8DX9L	PIN	GOUPILLE	PERNO
3	41	1	368 364 010		ENTRIEGELUNGSHEBEL		RELEASE LEVER	LEVIER DE DÉBLOQUAGE	PALANCA DE DESBLOQUEO
3	42	1	368 365 010		SPRENGRING	13.8DX20.3DX0.4T	CLIP	ANNEAU RESSORT	ANILLO ELÁSTICO
3	43	1	368 387 011		FEDER		SPRING	RESSORT	MUELLE
3	44	2	368 336 010		VENTILFEDER	19.2DX2.3DX27.4L	VALVE SPRING	RESSORT DE VANNE	MUELLE DE VÁLVULA
3	45	2	368 337 010		FEDERTELLER		SPRING RETAINER	CUVETTE DE RESSORT	CAJA DE RESORTE
3	46	1	368 334 013		EINLASSVENTIL	28.5DX5.5DX67.8L	INTAKE VALVE	VALVE D'ADMISSION	VÁLVULA DE ADMISIÓN
3	47	1	368 335 013		AUSLASSVENTIL	26.5DX5.5DX67.8L	EXHAUST VALVE	SOUPAPE D'EMISSION	VÁLVULA DE ESCAPE
3	48	4	383 100 300		BUCHSE		COLLET	DOUILLE	ENCHUFE
3	49	1	368 356 011		STEUERKETTE KPL.	100 LINK	TIMING CHAIN CPL.	CHAÎNE DE DISTRIBUTION CPL.	CADENA DE DISTRIBUCIÓN CPL.
3	50	1	368 369 110		KETTENSANNER		TENSIONER	TENDEUR DE CHAÎNE	SENSOR DE CADENA
3	51	1	368 371 010		FEDER	10DX1.8DX14L N=4.5	SPRING	RESSORT	MUELLE
3	52	1	368 369 020		STIFT	6DX13DX34L	PIN	GOUPILLE	PERNO
3	53	1	368 369 131		FÜHRUNGSBLECH		CHAIN GUIDE	TÔLE DE GUIDAGE	CHAPA DE GUÍA
3	54	1	368 350 020		ACHSE F. KIPPHEBEL KPL.	6DX46L	ROCKER SHAFT CPL.	AXE DE CULBUTEUR CPL.	EJE DE BALANCINES CPL.
3	55	1	368 130 500		SPRENGRING		CLIP	ANNEAU RESSORT	ANILLO ELÁSTICO
3	56	1	368 362 010		KIPPHEBEL (IN) KPL.		ROCKER ARM (IN) ASSY.	CULBUTEUR (IN) CPL.	GRUPO DEL BALANCÍN (IN) CPL.
3	57	1	368 362 020		KIPPHEBEL KPL.		ROCKER ARM ASSY.	CULBUTEUR CPL.	GRUPO DEL BALANCÍN CPL.
3	58	1	368 905 002		STELLSCHRAUBE	M5	ADJUST SCREW	VIS DE REGLAGE	TORNILLO DE AJUSTE
3	59	1	368 905 002		STELLSCHRAUBE	M5	ADJUST SCREW	VIS DE REGLAGE	TORNILLO DE AJUSTE
3	60	1	368 005 003		MUTTER	M5	NUT	ECROU	TUERCA
3	61	1	368 005 003		MUTTER	M5	NUT	ECROU	TUERCA
3	62	1	383 006 002		BOLZEN	M6X1.0X14DX12L	BOLT	BOULON	BULÓN
3	85	1	368 304 013		SCHALLDÄMPFER KPL.		MUFFLER CPL.	POT D'ECHAPPEMENT CPL.	SILENCIOSO CPL.
3	86	1	368 526 010		ABBLENDBLECH		BAFFLE	TÔLE CPL.	CHAPA CPL.
3	87	2	368 008 027		BOLZEN	M8X33L	BOLT	BOULON	BULÓN
3	88	2	368 380 800		MUTTER		NUT	ECROU	TUERCA
3	89	1	368 008 032		BOLZEN		BOLT	BOULON	BULÓN
3	90	1	368 006 001		BOLZEN	M6X1.0X14DX8L	BOLT	BOULON	BULÓN
3	91	1	368 352 011		DICHTUNG		GASKET	JOINT	JUNTA
3	92	1	368 352 011		DICHTUNG		GASKET	JOINT	JUNTA

GE-4300 L



Seite / Page	Pos.	GE-4300 L	Teil-Nr. Part No. No. de pièce No. de pieza	Hinweise Notes Renseign. Nota	Bezeichnung	Spezifikation Specification	Description	Désignation	Denominación
3	93	2	368 200 828		MUTTER	M8	NUT	ECROU	TUERCA
3	94	1	368 392 010		FLANSCH		FLANGE	BRIDE	BRIDA
3	95	1	368 372 100		ABDECKUNG		COVER	COUVERCLE	CUBIERTA
3	96	1	368 372 210		SIEB		SCREEN	TAMIS	TAMIZ
3	97	1	374 350 516		SCHRAUBE KPL.		SCREW ASSY.	VIS CPL.	TORNILLO CPL.
3	98	1	367 180 500		MUTTER	M5	NUT	ECROU	TUERCA
3	99	1	368 326 220		LUFTFILTER KPL.	GENERATOR	AIR CLEANER ASSY.	FILTRE À AIR CPL.	FILTRO DE AIRE CPL.
3	100	1	368 326 350		LUFTFILTERGEHÄUSE KPL.		CLEANER BODY CPL.	FOND A AIR CPL.	FONDO DE AIRE CPL.
3	101	1	368 326 500		DICHTUNG		GASKET	JOINT	JUNTA
3	102	1	368 326 460		ABDECKUNG KPL.		COVER CPL.	COUVERCLE CPL.	CUBIERTA CPL.
3	103	1	368 326 120		FILTER	GENERATOR	FILTER	FILTRE	FILTRO
3	104	2	368 380 600		MUTTER	M6	NUT	ECROU	TUERCA
3	105	1	368 108 000		SCHLAUCH	1 m	RUBBER PIPE	TUYAU SOUPLE	TUBO FLEXIBLE
3	106	1	368 329 021		ABSCHIRMBLECH KPL.	W/GASKET	INSULATOR CPL.	TÔLE DE DERIVATION CPL.	CHAPA DE DISIPACIÓN CPL.
3	107	1	368 359 023		DICHTUNG	T=0.5	GASKET	JOINT	JUNTA
3	108	1	368 359 033		DICHTUNG	T=0.5	GASKET	JOINT	JUNTA
3	109	1	368 390 040		HALTERUNG KPL.		BRACKET CPL.	FIXATION CPL.	SOPORTE CPL.
3	110	1	368 006 005		BOLZEN		BOLT	BOULON	BULÓN
3	111	1	368 006 015		BOLZEN		BOLT	BOULON	BULÓN

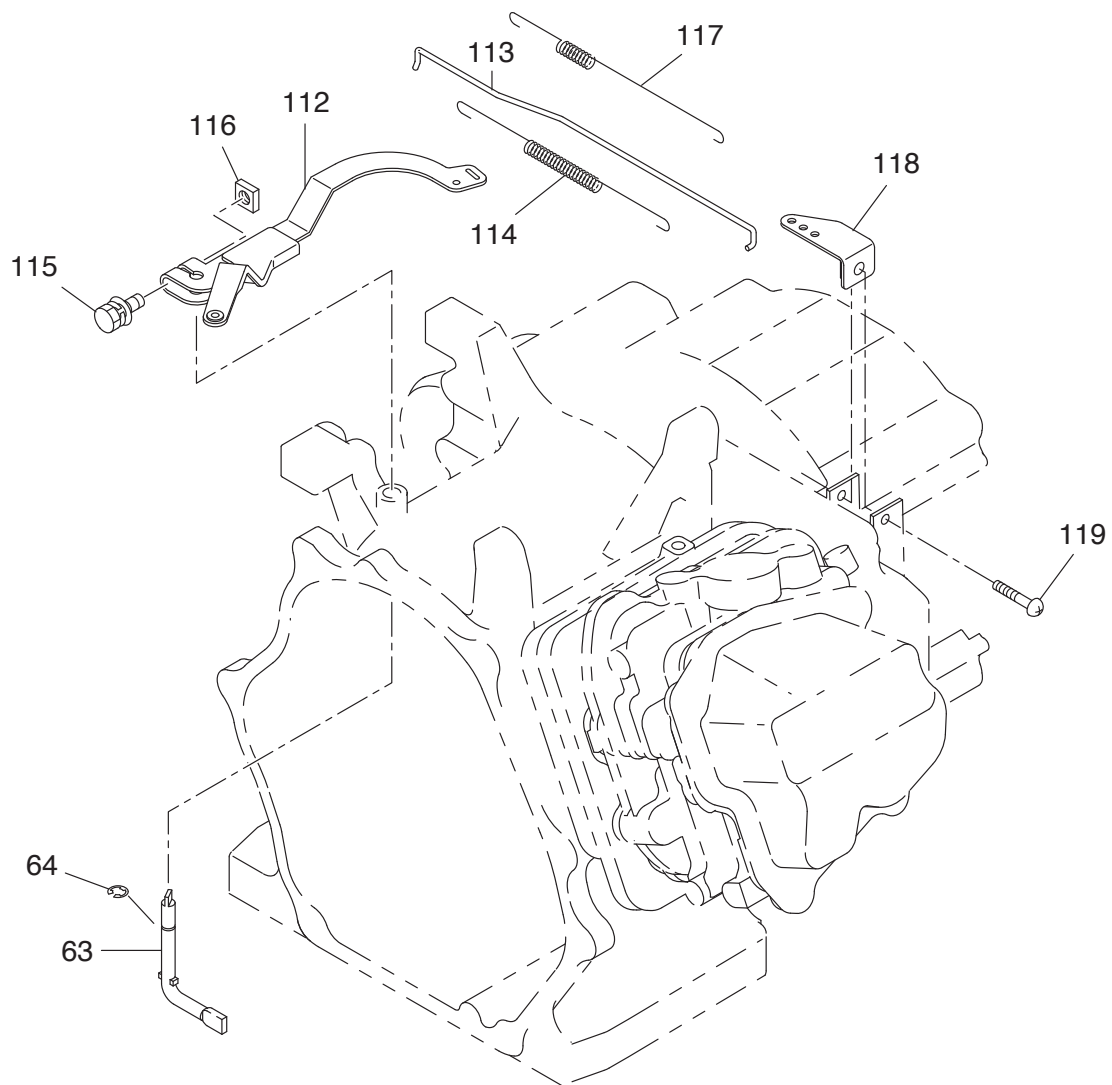

GE-4300 L



Seite / Page	Pos.	GE-4300 L	Teil-Nr. Part No. No. de pièce No. de pieza	Hinweise Notes Renseign. Nota	Bezeichnung	Spezifikation Specification	Description	Désignation	Denominación
4	63	1	368 422 013		REGLERWELLE		GOVERNOR SHAFT	ARBRE RÉGULATEUR	EJE REGULADOR
4	64	1	368 130 500		SPRENGRING		CLIP	ANNEAU RESSORT	ANILLO ELÁSTICO
4	112	1	368 423 014		REGLERHEBEL		GOVERNOR LEVER	LEVIER RÉGULATEUR	PALANCA REGULADOR
4	113	1	381 427 011		REGLERSTANGE KPL.		GOVERNOR ROD CPL.	BARRE RÉGULATEUR CPL.	VARILLA REGULADOR CPL.
4	114	1	368 428 012		FEDER	7DX0.5DX182L N=16	SPRING	RESSORT	MUELLE
4	115	1	368 006 024		SCHRAUBE MIT SCHEIBE		BOLT & WASHER ASSY.	VIS AVEC RONDELLE	TORNILLO CON ARANDELA
4	116	1	368 606 002		MUTTER	M6X1.0X4.9H	NUT	ECROU	TUERCA
4	117	1	368 425 250		FEDER		SPRING	RESSORT	MUELLE
4	118	1	368 480 010		PLATTE KPL.		PLATE CPL.	PLAQUE CPL.	PLACA CPL.
4	119	1	388 310 555		SCHRAUBE	M5X55	SCREW	VIS	TORNILLO

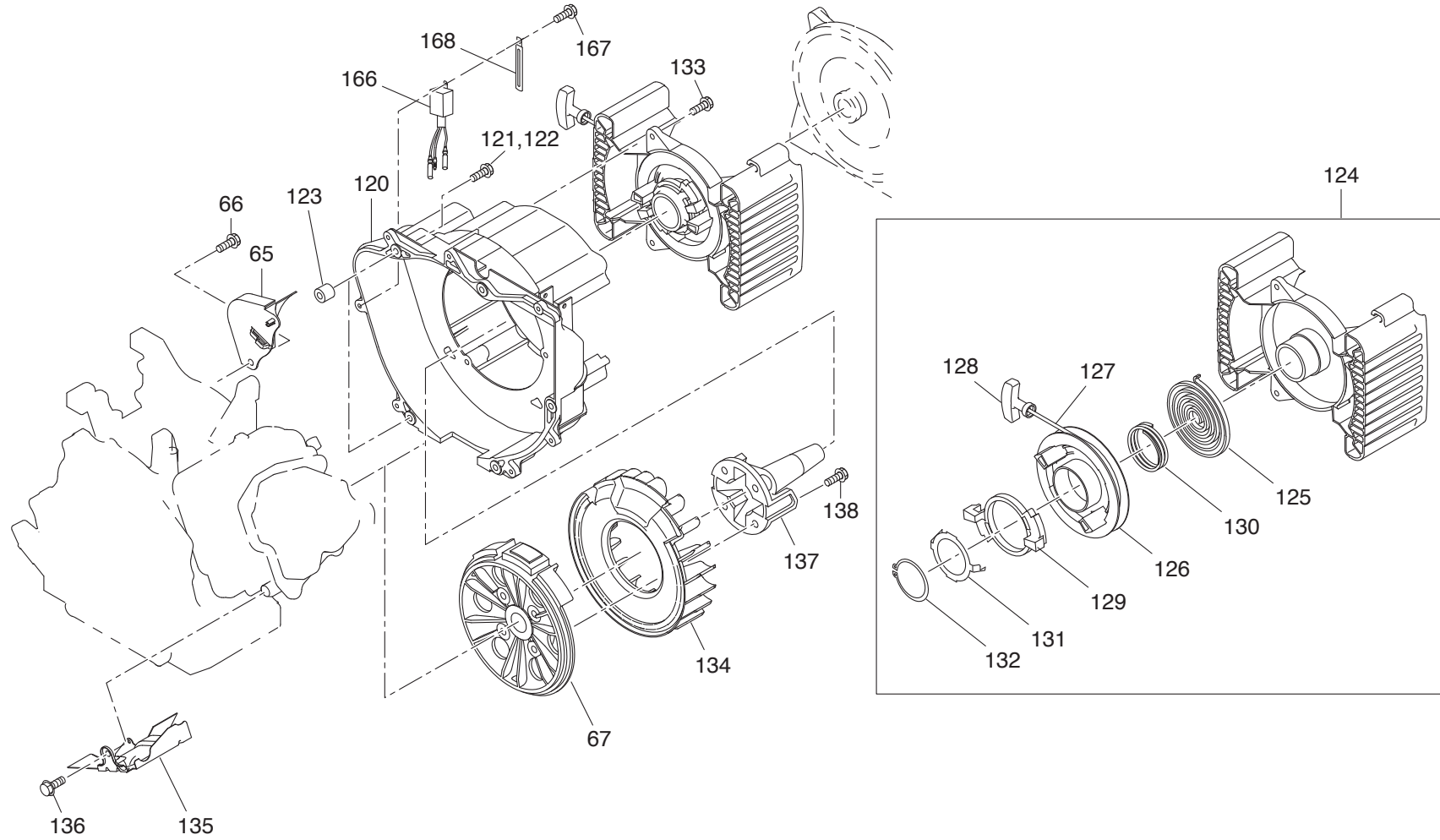

GE-4300 L



Seite / Page	Pos.	GE-4300 L	Teil-Nr. Part No. No. de pièce No. de pieza	Hinweise Notes Renseign. Nota	Bezeichnung	Spezifikation Specification	Description	Désignation	Denominación
5	65	1	368 527 111		ABLENDBLECH KPL.		BAFFLE CPL.	TÔLE CPL.	CHAPA CPL.
5	66	1	368 650 812		BOLZEN		BOLT	BOULON	BULÓN
5	67	1	368 792 620		POLRAD KPL.		FLYWHEEL CPL.	ROUE POLAIRE CPL.	VOLANTE ENCEND. CPL.
5	120	1	381 520 011		VENTILATORGEHÄUSE		BLOWER HOUSING	CARTER DE VENTILATEUR	CARCASA DEL VENTILADOR
5	121	1	368 140 630		SCHRAUBE MIT SCHEIBE		BOLT & WASHER ASSY.	VIS AVEC RONDELLE	TORNILLO CON ARANDELA
5	122	4	368 140 660		SCHRAUBE MIT SCHEIBE		BOLT & WASHER ASSY.	VIS AVEC RONDELLE	TORNILLO CON ARANDELA
5	123	2	368 400 811		STIFT	8X10	PIN	GOUPILLE	PERNO
5	124	1	368 504 011		STARTER KPL.		RECOIL STARTER ASSY.	STARTER CPL.	ARRANQUE CPL.
5	125	1	368 504 020		FEDER		SPRING	RESSORT	MUELLE
5	126	1	368 504 030		SEILTROMMEL		REEL	TAMBOUR DE CÂBLE	TAMBOR PARA CUERDA
5	127	1	368 504 080		ANWERFSEIL		STARTER ROPE	CÂBLE DE DÉMARRAGE	CORDÓN DE ARRANQUE
5	128	1	368 504 090		ANWERFGRIFF		STARTER KNOB	POIGNEE DE LANCEMENT	TIRADOR DE ARRANQUE
5	129	1	368 504 040		SPERRKLINKE		RATCHET	CLIQUET D'ARRÊT	TRINQUETE
5	130	1	368 504 050		FEDER		SPRING	RESSORT	MUELLE
5	131	1	368 504 070		REIBSCHEIBE		FRICTION PLATE	DISCQUE DE FRICTION	RODAJA DE FRICCION
5	132	1	368 504 060		SICHERUNGSRING		RETAINING RING	CIRCLIP	ANILLO SEGURIDAD
5	133	3	368 006 014		BOLZEN	M6X18L	BOLT	BOULON	BULÓN
5	134	1	368 541 100		GEBLÄSE		COOLING BLOWER	VENTILATEUR	VENTILADOR
5	135	1	368 527 021		ABLENDBLECH		BAFFLE	TÔLE CPL.	CHAPA CPL.
5	136	1	383 006 002		BOLZEN	M6X1.0X14DX12L	BOLT	BOULON	BULÓN
5	137	1	368 244 010		WELLE		SHAFT	ARBRE	EJE
5	138	4	368 010 011		BOLZEN	M8X27L	BOLT	BOULON	BULÓN
5	166	1	368 110 431		STEUERUNG, SCHWIMMER		FLOAT C/U	COMMANDE, FLOTTEUR	MANDO FLOTADOR
5	167	1	383 006 002		BOLZEN	M6X1.0X14DX12L	BOLT	BOULON	BULÓN
5	168	1	368 600 025		KLAMMER		CLAMP	CRAMPON	GRAPA

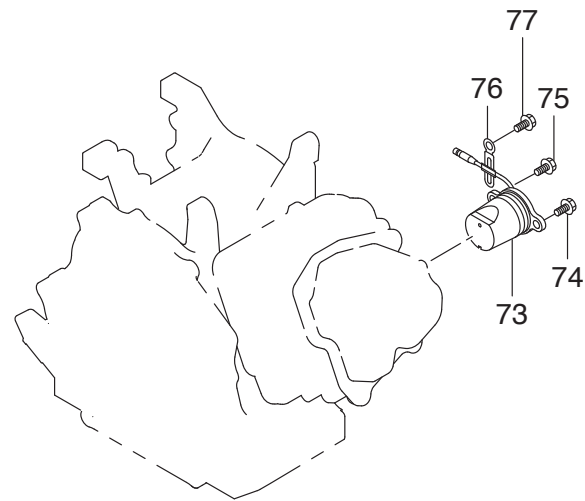
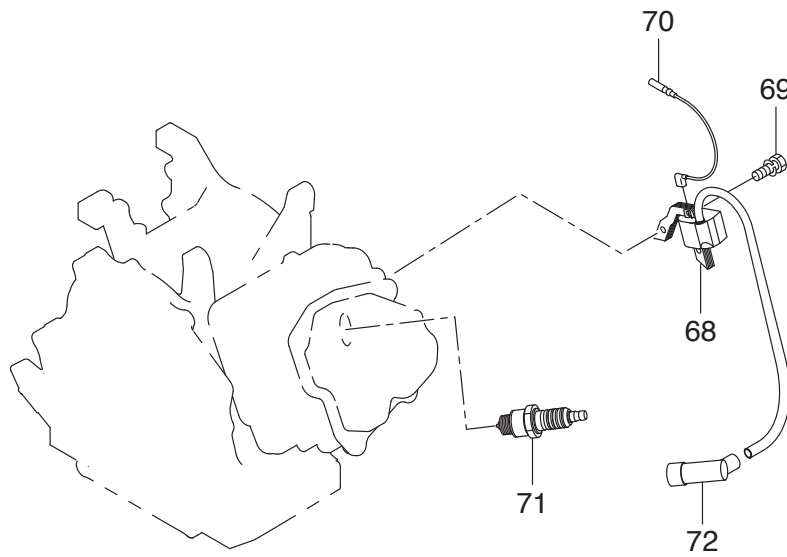

GE-4300 L



Seite / Page	Pos.	GE-4300 L	Teil-Nr. Part No. No. de pièce No. de pieza	Hinweise Notes Renseign. Nota	Bezeichnung	Spezifikation Specification	Description	Désignation	Denominación
6	68	1	368 794 300		ZÜNDSPULE KPL.	MARK AB	IGNITION COIL CPL.	BOBINE D' ALLUMAGE CPL.	BOBINA DE ENCENDIDO CPL.
6	69	2	368 140 625		SCHRAUBE MIT SCHEIBE		BOLT & WASHER ASSY.	VIS AVEC RONDELLE	TORNILLO CON ARANDELA
6	70	1	368 731 021		KABEL KPL.		WIRE CPL.	CÂBLE COMPLET	CABLE CPL
6	71	1	368 014 015		ZÜNDKERZE	NGK BR6HS	SPARK PLUG	BOUGIE	BUIJA
6	72	1	368 500 027		ZÜNDKERZENSTECKER		SPARK PLUG CAP	FICHE DE BOUGIE	TAPA BUIJA
6	73	1	368 763 014		ÖLSENSOR KPL.		OIL SENSOR CPL.	CAPTEUR D'HUILE CPL.	SENSOR DE ACEITE CPL.
6	74	1	368 140 616		SCHRAUBE MIT SCHEIBE		BOLT & WASHER ASSY.	VIS AVEC RONDELLE	TORNILLO CON ARANDELA
6	75	1	368 006 026		SCHRAUBE MIT SCHEIBE		BOLT & WASHER ASSY.	VIS AVEC RONDELLE	TORNILLO CON ARANDELA
6	76	1	368 755 011		KLAMMER		CLAMP	CRAMPON	GRAPA
6	77	1	368 206 005		BOLZEN		BOLT	BOULON	BULÓN

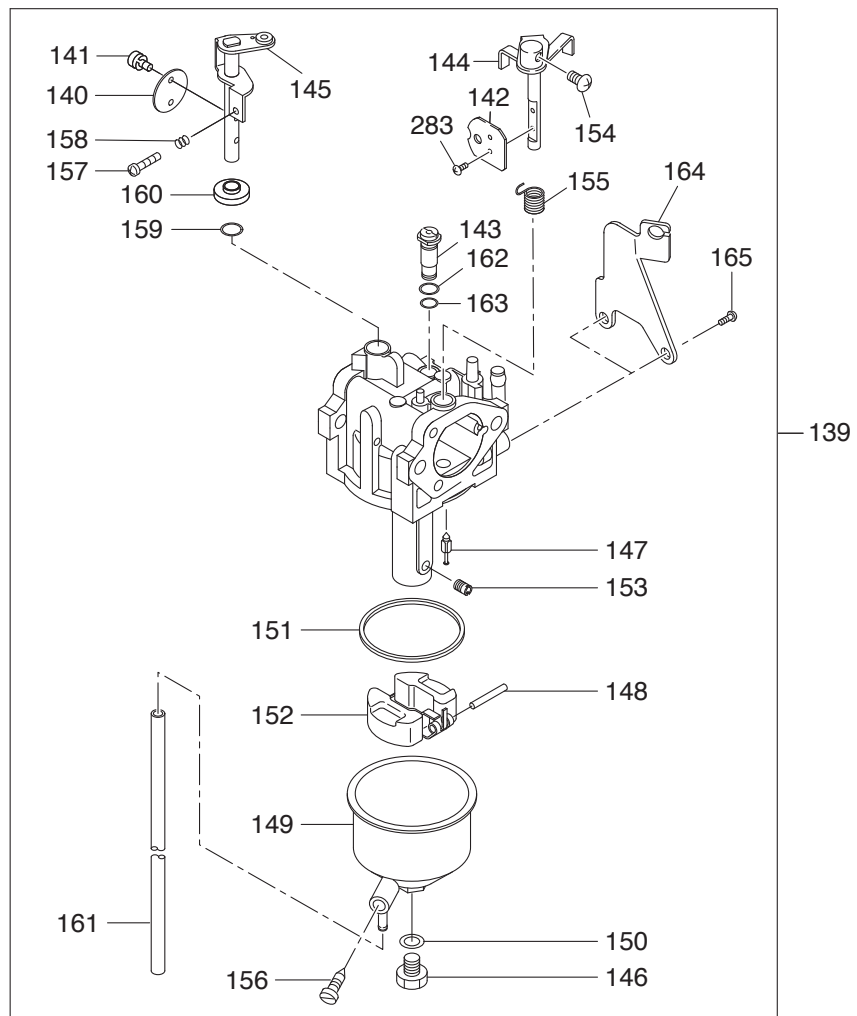

GE-4300 L



Seite / Page	Pos.	GE-4300 L	Teil-Nr. Part No. No. de pièce No. de pieza	Hinweise Notes Renseign. Nota	Bezeichnung	Spezifikation Specification	Description	Désignation	Denominación
7	139	1	368 623 310		VERGASER KPL.		CARBURETOR ASSY.	CARBURATEUR CPL.	CARBURADOR CPL.
7	140	1	368 625 350		DROSSELKLAPPE		THROTTLE VALVE	CLAPET D'ÉTRANGLEMENT	VÁLVULA REG.
7	141	2	368 624 500		SCHRAUBE		SCREW	VIS	TORNILLO
7	142	1	368 625 260		CHOKEKLAPPE		CHOKE VALVE	CLAPET DE STARTER	TAPA DEL CHOKE
7	143	1	368 624 200		DÜSE		JET	BUSE	CHICLÉ
7	144	1	368 625 210		CHOKEHEBEL		CHOKE LEVER	LEVIER DE STARTER	PALANCA ESTRANGUL. AIRE
7	145	1	381 625 300		UNTER-REP.-SATZ DROSSELWELLE		SHAFT SUB ASSY(THROTTLE)	JEU AXE CLAPET D'ÉTRANG.	JUEGO EJE VÁLVULA REG.
7	146	1	368 624 530		SCHRAUBE		SCREW	VIS	TORNILLO
7	147	1	368 625 000		EINLASSNADEL KPL.		VALVE, INLET NEEDLE CPL.	POINTEAU D'ARRVÉE D'ESSENCE CPL.	AGUJA DE VÁLVULA CPL.
7	148	1	368 625 150		STIFT		PIN	GOUPILLE	PERNO
7	149	1	368 625 530		SCHWIMMERKÖRPER		FLOAT BODY	CORPS DU FLOTTEUR	CUERPO DEL FLOTADOR
7	150	1	368 623 500		DICHTUNG		GASKET	JOINT	JUNTA
7	151	1	381 625 400		DICHTUNG		GASKET	JOINT	JUNTA
7	152	1	368 625 050		UNTER-REP.-SATZ SCHWIMMER		FLOAT SUB ASSY	NÉCESSAIRE DE RÉPARATIONS FLOTTEUR	JUEGO REPARACIÓN FLOTADOR INFERIOR
7	153	1	381 624 000		DÜSE		JET	BUSE	CHICLÉ
7	154	1	368 624 560		SCHRAUBE		SCREW	VIS	TORNILLO
7	155	1	368 624 470		FEDER		SPRING	RESSORT	MUELLE
7	156	1	368 625 810		SCHRAUBE		SCREW	VIS	TORNILLO
7	157	1	368 623 531		STELLSCHRAUBE		ADJUST SCREW	VIS DE REGLAGE	TORNILLO DE AJUSTE
7	158	1	368 624 450		FEDER		SPRING	RESSORT	MUELLE
7	159	1	368 625 610		TÜLLE		BUSH	PASSE-FIL	BOQUILLA
7	160	1	368 625 620		HÜLSE		COLLAR	DOUILLE	CASQUILLO
7	161	1	368 625 900		ROHR		VYNYL PIPE	TUBE	TUBO
7	162	1	368 624 520		O-RING		O RING	ANNEAU TORIQUE	ANILLO OBTURADOR
7	163	1	381 624 510		O-RING		O RING	ANNEAU TORIQUE	ANILLO OBTURADOR
7	164	1	381 625 760		HALTERUNG		BRACKET	FIXATION	SOPORTE
7	165	2	381 625 800		SCHRAUBE		SCREW	VIS	TORNILLO
7	283	2	368 624 500		SCHRAUBE		SCREW	VIS	TORNILLO

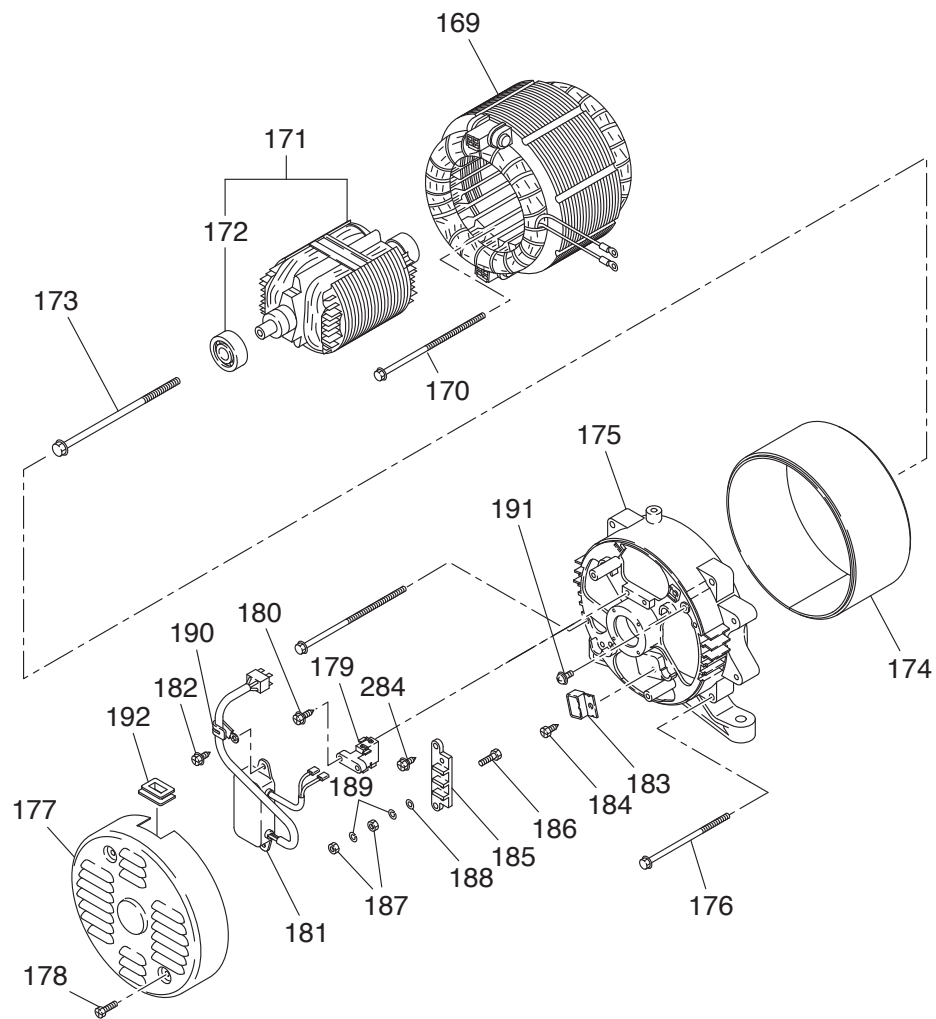

GE-4300 L



Seite / Page	Pos.	GE-4300 L	Teil-Nr. Part No. No. de pièce No. de pieza	Hinweise Notes Renseign. Nota	Bezeichnung	Spezifikation Specification	Description	Désignation	Denominación
8	169	1	368 217 520		STATOR KPL.		STATOR ASSY.	STATOR CPL.	ESTADOR CPL.
8	170	2	368 230 520		BOLZEN		BOLT	BOULON	BULÓN
8	171	1	368 211 610		ROTOR		ROTOR CPL.	ROTOR CPL.	ROTOR CPL.
8	172	1	368 210 010		KUGELLAGER		BALL BEARING	ROULEMENT A BILLES	RODAMIENTO DE BOLAS
8	173	1	381 210 530		BOLZEN	M10X185L	BOLT	BOULON	BULÓN
8	174	1	368 230 610		ABDECKUNG		COVER	COUVERCLE	CUBIERTA
8	175	1	368 230 720		ABDECKUNG		COVER	COUVERCLE	CUBIERTA
8	176	4	377 210 510		BOLZEN	M6X115L	BOLT	BOULON	BULÓN
8	177	1	368 230 510		ABDECKUNG		COVER	COUVERCLE	CUBIERTA
8	178	2	368 210 550		SCHRAUBE MIT SCHEIBE		BOLT & WASHER ASSY.	VIS AVEC RONDELLE	TORNILLO CON ARANDELA
8	179	1	368 231 010		KOHLEBÜRSTE KPL.		BRUSH CPL.	CHARBON CPL.	ESCOBILLA CPL.
8	180	1	368 210 620		SCHRAUBE	M5X18L	SCREW	VIS	TORNILLO
8	181	1	368 230 010		AUTOMATISCHER SPANNUNGSREGLER KPL.		AVR CPL.	REGULATEUR DE LA TENSION AUTOM. CPL.	REGULADOR AUTOM. DE LA TENSION CPL.
8	182	2	320 210 510		SCHRAUBE		SCREW	VIS	TORNILLO
8	183	1	368 231 210		DIODE KPL.		DIODE CPL.	DIODE CPL.	DIODO CPL.
8	184	1	368 210 520		SCHRAUBE		SCREW	VIS	TORNILLO
8	185	1	381 210 520		SOCKEL		BASE	SOCLE	BASE
8	186	4	368 210 610		BOLZEN		BOLT	BOULON	BULÓN
8	187	8	367 210 510		MUTTER	M5	NUT	ECROU	TUERCA
8	188	4	383 210 530		SCHEIBE		WASHER	RONDELLE	ARANDELA
8	189	8	368 210 540		FEDERSCHEIBE		SPRING WASHER	RONDELLE A RESSORT	ARANDELA ELASTICO
8	190	1	368 210 600		KLAMMER		CLAMP	CRAMPON	GRAPA
8	191	1	368 210 530		SCHRAUBE		SCREW	VIS	TORNILLO
8	192	1	368 450 020		TÜLLE		GROMMET	PASSE-FIL	CAPERUCITA
8	284	2	320 210 510		SCHRAUBE		SCREW	VIS	TORNILLO

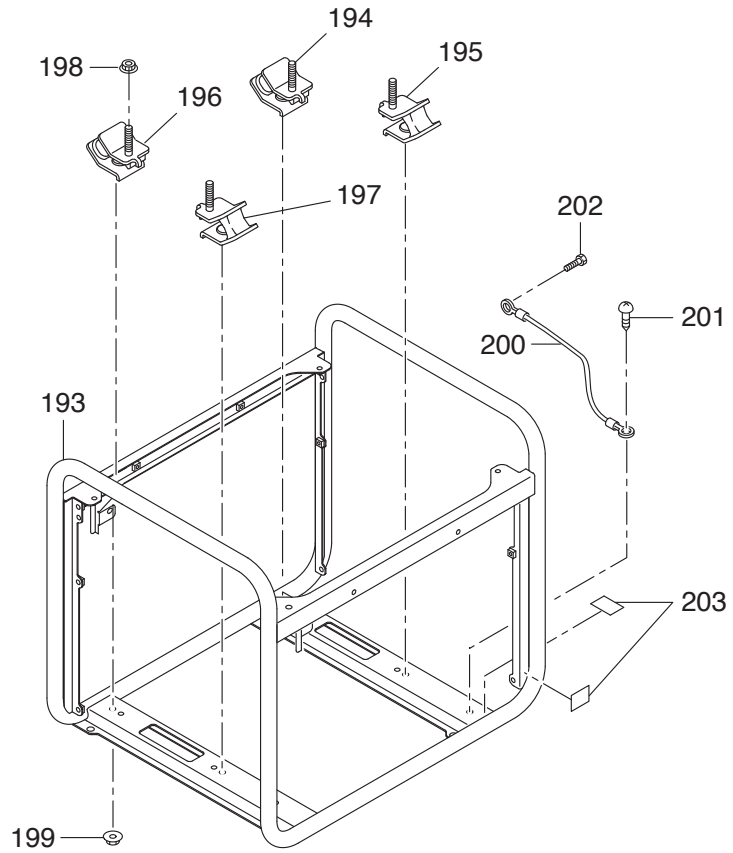

GE-4300 L



Seite / Page	Pos.	GE-4300 L	Teil-Nr. Part No. No. de pièce No. de pieza	Hinweise Notes Renseign. Nota	Bezeichnung	Spezifikation Specification	Description	Désignation	Denominación
9	193	1	368 300 011		RAHMEN KPL.		FRAME CPL.	CADRE	MARKO
9	194	1	368 302 130		HALTERUNG KPL. (R)	35L	MOUNT CPL. (R)	FIXATION CPL. , DROITE	SOPORTE CPL., DERECHO
9	195	1	368 302 140		HALTERUNG KPL. (L)	35L	MOUNT CPL. (L)	FIXATION CPL. , GAUCHE	SOPORTE CPL., IZQUIERDO
9	196	1	368 302 030		HALTERUNG KPL. (R)	35L	MOUNT CPL. (R)	FIXATION CPL. , DROITE	SOPORTE CPL., DERECHO
9	197	1	368 302 040		HALTERUNG KPL. (L)	35L	MOUNT CPL. (L)	FIXATION CPL. , GAUCHE	SOPORTE CPL., IZQUIERDO
9	198	4	368 380 800		MUTTER		NUT	ECROU	TUERCA
9	199	4	368 380 800		MUTTER		NUT	ECROU	TUERCA
9	200	1	368 480 920		ERDUNGSLEITUNG KPL.		EARTH WIRE CPL.	CONDUCTEUR DE MISE À LA TERRE CPL.	CABLE A TIERRA CPL.
9	201	1	368 006 012		SCHRAUBE		SCREW	VIS	TORNILLO
9	202	1	368 030 812		BOLZEN		BOLT	BOULON	BULÓN
9	203	2	368 200 265		SCHILD		LABEL	PLAQUE	CALCOMANIA

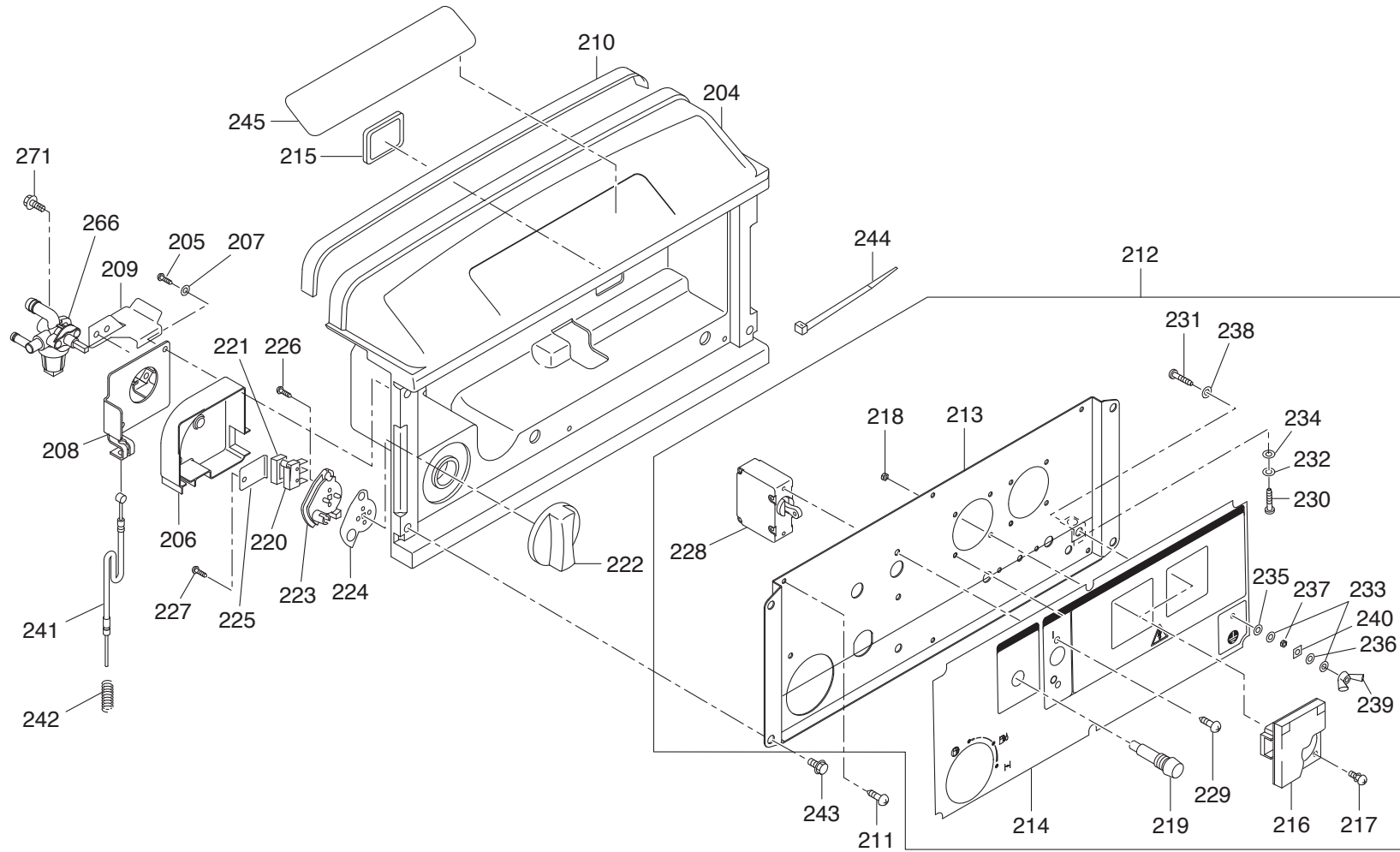

GE-4300 L



Seite / Page	Pos.	GE-4300 L	Teil-Nr. Part No. No. de pièce No. de pieza	Hinweise Notes Renseign. Nota	Bezeichnung	Spezifikation Specification	Description	Désignation	Denominación
10	204	1	368 500 030		ABDECKUNG KPL.		COVER CPL.	COUVERCLE CPL.	CUBIERTA CPL.
10	205	2	368 004 007		SCHNEIDSCHRAUBE		TAPPING SCREW	VIS DE COUPE	TORNILLO DE ROSCA CORTANTE
10	206	1	368 460 010		ABDECKUNG		COVER	COUVERCLE	CUBIERTA
10	207	2	368 100 400		SCHEIBE		WASHER	RONDELLE	ARANDELA
10	208	1	368 460 121		HALTERUNG		BRACKET	FIXATION	SOPORTE
10	209	1	368 460 330		PLATTE KPL.		PLATE CPL.	PLAQUE CPL.	PLACA CPL.
10	210	1	368 573 110		ABDICHTUNG		GASKET	JOINT	JUNTA
10	211	6	368 499 040		SCHNEIDSCHRAUBE	M4X10MM	TAPPING SCREW	VIS DE COUPE	TORNILLO DE ROSCA CORTANTE
10	212	1	368 434 200		BEDIENFELD KPL.		CONTROL PANEL ASSY.	PANNEAU DE COMMANDE COMPLET	PANEL CONTROL COMPLETO
10	213	1	368 451 190		PLATTE KPL.		PLATE CPL.	PLAQUE CPL.	PLACA CPL.
10	214	1	368 492 591		BLECH		SHEET	TÔLE	CHAPA
10	215	1	368 750 010		TÜLLE		GROMMET	PASSE-FIL	CAPERUCITA
10	216	2	368 406 210		WECHSELSTROM-STECKDOSE	AC250V 16A	AC RECEPTACLE	PRISE COURANT ALTERNATIF	BASE DE ENCHUFE DE CA
10	217	8	368 360 312		SCHRAUBE MIT SCHEIBE KPL.		SCREW & WASHER ASSY.	VIS AVEC RONDELLE CPL.	TORNILLO CON ARANDELA CPL.
10	218	8	368 170 300		MUTTER	M5	NUT	ECROU	TUERCA
10	219	1	368 406 660		NEONLAMPE		NEON LAMP	LAMPE AU NÉON	LÁMPARA DE NEÓN
10	220	1	368 418 110		MIKROSCHALTER		MICRO SWITCH	INTERRUPTEUR	INTERRUPTOR
10	221	1	368 460 400		DISTANZSTÜCK		SPACER	PIECE DISTANCE	ANILLO SEPARADOR
10	222	1	368 420 100		SCHALTER		CONTROL DIAL	COMMUTATEUR	INTERRUPTOR
10	223	1	368 420 200		HALTERUNG		BRACKET	FIXATION	SOPORTE
10	224	1	368 420 302		PLATTE		PLATE	PLAQUE	PLACA
10	225	1	368 460 150		HALTERUNG		BRACKET	FIXATION	SOPORTE
10	226	2	368 418 140		SCHNEIDSCHRAUBE	M3X16L	TAPPING SCREW	VIS DE COUPE	TORNILLO DE ROSCA CORTANTE
10	227	1	368 004 007		SCHNEIDSCHRAUBE		TAPPING SCREW	VIS DE COUPE	TORNILLO DE ROSCA CORTANTE
10	228	1	368 431 580		UNTERBRECHERSCHALTER	AC250V 15A	CIRCUIT BREAKER	DISJONCTEUR	DISYUNTOR DE CIRCUITO
10	229	2	368 790 110		SCHRAUBE MIT SCHEIBE KPL.		SCREW & WASHER ASSY.	VIS AVEC RONDELLE CPL.	TORNILLO CON ARANDELA CPL.
10	230	1	368 430 610		SCHRAUBE		SCREW	VIS	TORNILLO
10	231	1	368 880 010		SCHRAUBE	M5X18	SCREW	VIS	TORNILLO
10	232	1	368 000 500		FEDERSCHEIBE		SPRING WASHER	RONDELLE A RESSORT	ARANDELA ELASTICO
10	233	2	368 000 500		FEDERSCHEIBE		SPRING WASHER	RONDELLE A RESSORT	ARANDELA ELASTICO
10	234	1	368 499 030		SCHEIBE		WASHER	RONDELLE	ARANDELA
10	235	1	368 499 030		SCHEIBE		WASHER	RONDELLE	ARANDELA
10	236	1	368 499 030		SCHEIBE		WASHER	RONDELLE	ARANDELA
10	237	1	368 499 020		MUTTER		NUT	ECROU	TUERCA
10	238	1	368 300 500		SICHERUNGSCHEIBE		LOCK WASHER	RONDELLE DE SÉCURITÉ	ARANDELA SEGURIDAD
10	239	1	368 499 010		MUTTER		NUT	ECROU	TUERCA
10	240	1	368 421 010		PLATTE		PLATE	PLAQUE	PLACA
10	241	1	368 460 210		KABEL KPL.		CHOKE WIRE CPL.	CÂBLE CPL.	CABLE CPL.
10	242	1	368 450 010		FEDER		SPRING	RESSORT	MUELLE
10	243	4	368 006 019		SCHRAUBE		SCREW	VIS	TORNILLO
10	244	5	368 300 002		BAND		WIRE BAND	BANDE	BANDA
10	245	1	368 900 232		SCHILD		LABEL	PLAQUE	CALCOMANIA
10	266	1	368 201 030		KRAFTSTOFFFILTER KPL.		STRAINER SCREEN CPL.	TAMIS CPL.	TAMIZ CPL.
10	271	1	383 006 002		BOLZEN	M6X1.0X14DX12L	BOLT	BOULON	BULÓN

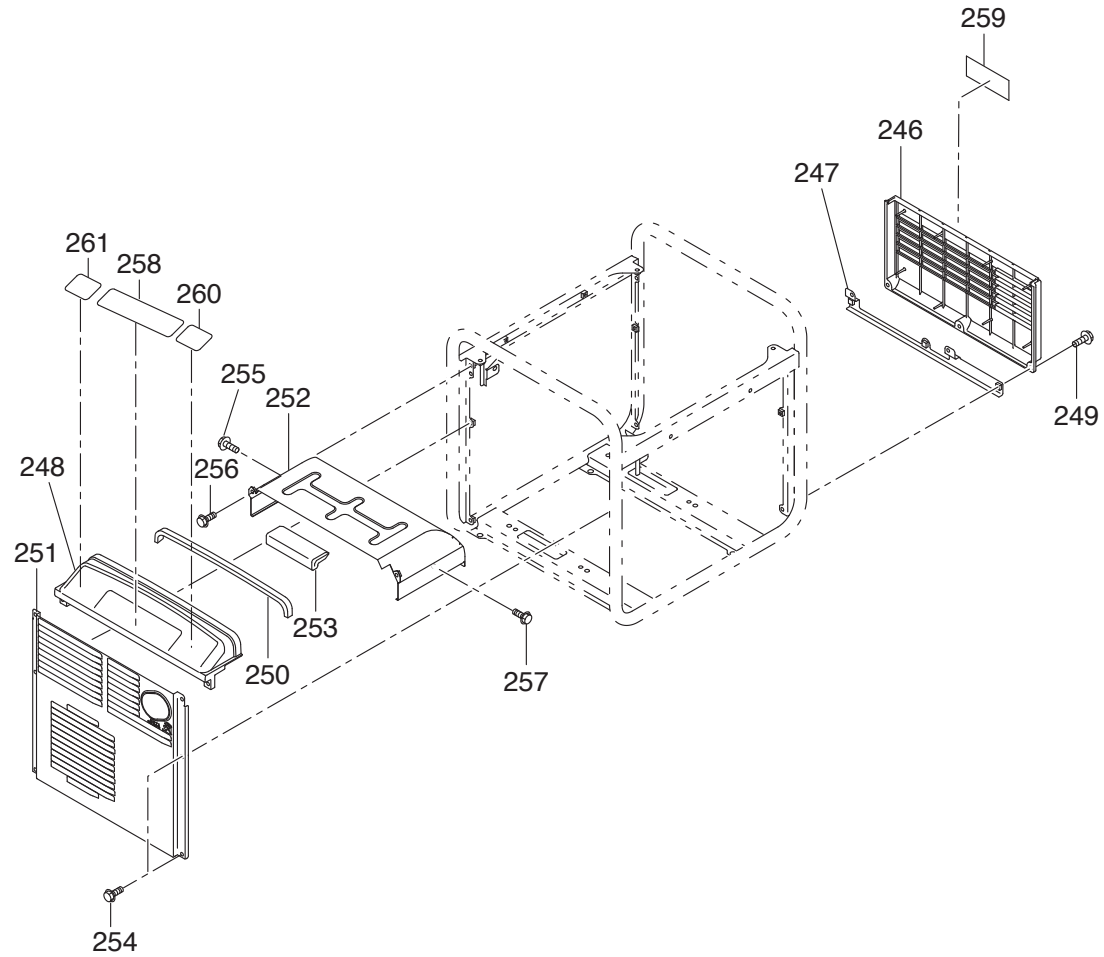

GE-4300 L



Seite / Page	Pos.	GE-4300 L	Teil-Nr. Part No. No. de pièce No. de pieza	Hinweise Notes Renseign. Nota	Bezeichnung	Spezifikation Specification	Description	Désignation	Denominación
11	246	1	368 501 010		ABDECKUNG KPL.		COVER CPL.	COUVERCLE CPL.	CUBIERTA CPL.
11	247	1	368 355 010		HALTERUNG KPL.		BRACKET CPL.	FIXATION CPL.	SOPORTE CPL.
11	248	1	381 505 010		ABDECKUNG		COVER	COUVERCLE	CUBIERTA
11	249	3	368 006 018		BOLZEN	M6X1.0X14DX18L	BOLT	BOULON	BULÓN
11	250	1	368 573 110		ABDICHTUNG		GASKET	JOINT	JUNTA
11	251	1	368 562 010		VERBRENNUNGSSCHUTZ KPL.		MUFFLER COVER CPL.	PROTECTION DE COMBUSTION CPL.	PROTECCIÓN CONTRA COMBUSTIÓN CPL.
11	252	1	368 560 510		VERBRENNUNGSSCHUTZ KPL.		MUFFLER COVER CPL.	PROTECTION DE COMBUSTION CPL.	PROTECCIÓN CONTRA COMBUSTIÓN CPL.
11	253	1	368 570 050		ABDICHTUNG		GASKET	JOINT	JUNTA
11	254	6	368 006 018		BOLZEN	M6X1.0X14DX18L	BOLT	BOULON	BULÓN
11	255	1	368 006 008		BOLZEN	M6X12L	BOLT	BOULON	BULÓN
11	256	2	368 006 008		BOLZEN	M6X12L	BOLT	BOULON	BULÓN
11	257	1	368 006 008		BOLZEN	M6X12L	BOLT	BOULON	BULÓN
11	258	1	368 972 321		SCHILD		LABEL	PLAQUE	CALCOMANIA
11	259	1	368 952 564		SCHILD		LABEL	PLAQUE	CALCOMANIA
11	260	1	368 200 450		SCHILD		LABEL	PLAQUE	CALCOMANIA
11	261	1	368 200 541		SCHILD		LABEL	PLAQUE	CALCOMANIA

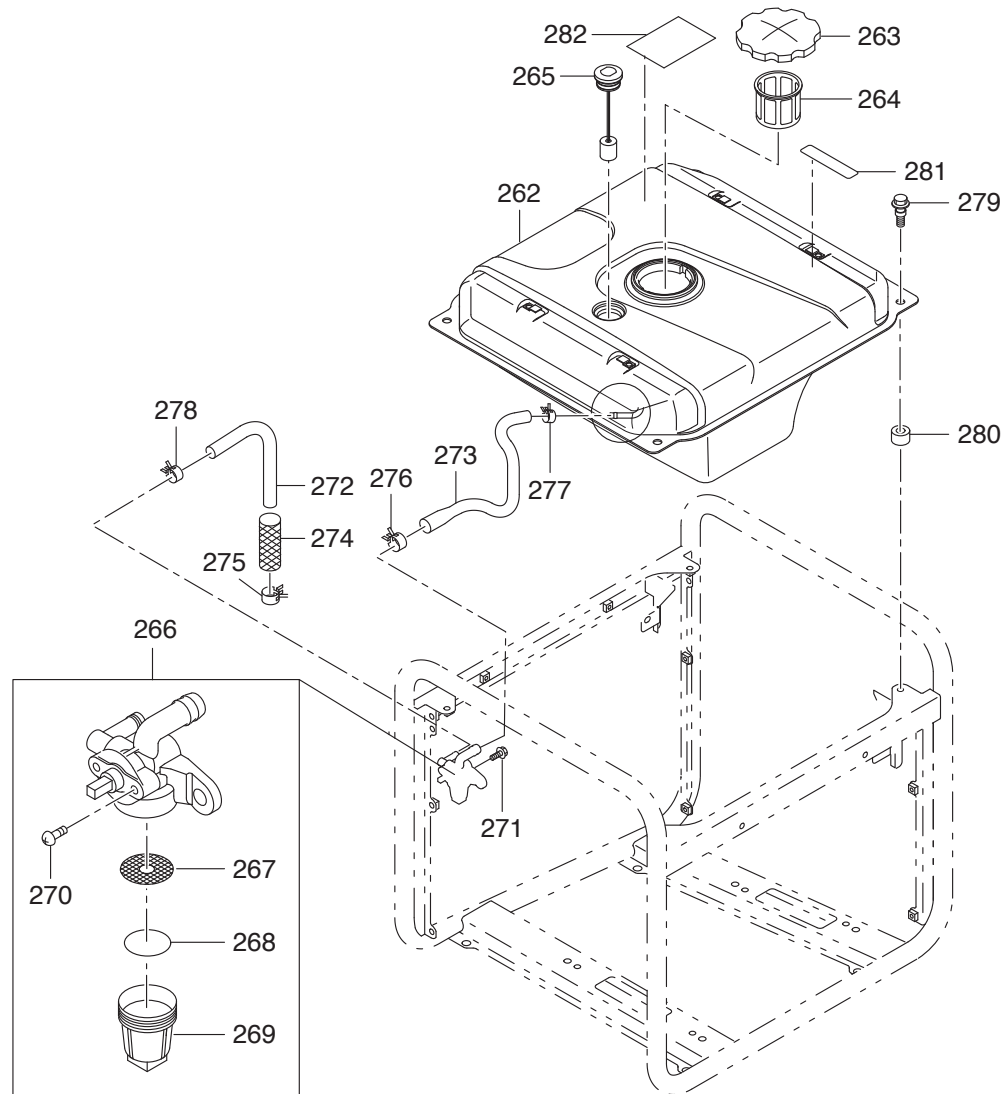

GE-4300 L



Seite / Page	Pos.	GE-4300 L	Teil-Nr. Part No. No. de pièce No. de pieza	Hinweise Notes Renseign. Nota	Bezeichnung	Spezifikation Specification	Description	Désignation	Denominación
12	262	1	368 601 031		KRAFTSTOFFTANK		FUEL TANK	RESERVOIR D'ESSENCE	DEPÓSITO DE COMBUSTIBLE
12	263	1	368 059 001		TANKVERSCHLUSS KPL.	59DX102DX15H	FUEL TANK CAP ASSY.	BOUCHON RÉSERVOIR CPL.	CIERRE DEPÓSITO CPL.
12	264	1	368 154 001		BENZINFILTER	54DX58DX48H	GASOLIN FILTER	FILTRE D'ESSENCE	FILTRO DE GASOLINA
12	265	1	368 800 150		KRAFTSTOFFSTANDANZEIGER KPL.		FUEL GAUGE CPL.	GAUGE À ESSENCE CPL.	INDICADOR DE COMBUSTIBLE CPL.
12	266	1	368 201 030		KRAFTSTOFFFILTER KPL.		STRAINER SCREEN CPL.	TAMIS CPL.	TAMIZ CPL.
12	267	1	368 200 932		FILTER		FILTER	FILTRE	FILTRO
12	268	1	368 200 641		DICHTUNG		PACKING	JOINT	JUNTA
12	269	1	368 200 781		GEFÄß		CUP	RÉCIPIENT	RECIPIENTE
12	270	2	368 200 479		SCHRAUBE		SCREW	VIS	TORNILLO
12	271	1	383 006 002		BOLZEN	M6X1.0X14DX12L	BOLT	BOULON	BULÓN
12	272	1	368 106 000		SCHLAUCH	6x12x160	RUBBER PIPE	TUYAU SOUPLE	TUBO FLEXIBLE
12	273	1	368 107 004		SCHLAUCH		RUBBER PIPE	TUYAU SOUPLE	TUBO FLEXIBLE
12	274	1	368 173 020		SCHUTZ		MESH PROTECTOR	PROTECTION	PROTECCIÓN
12	275	1	368 111 002		SCHLAUCHKLEMME	11.5DX8BX0.7T	HOSE CLAMP	COLLIER	ABRAZADERA
12	276	1	368 113 001		SCHLAUCHKLEMME	13.2DX10BX0.8T	HOSE CLAMP	COLLIER	ABRAZADERA
12	277	1	368 113 001		SCHLAUCHKLEMME	13.2DX10BX0.8T	HOSE CLAMP	COLLIER	ABRAZADERA
12	278	1	368 110 003		SCHLAUCHKLEMME	10DX8BX1T	HOSE CLAMP	COLLIER	ABRAZADERA
12	279	4	368 006 022		BOLZEN		BOLT	BOULON	BULÓN
12	280	4	368 390 001		GUMMI		RUBBER	BUTOIR CAOUTCHOUC	TOPE DE GOMA
12	281	1	368 971 021		SCHILD		LABEL	PLAQUE	CALCOMANIA
12	282	1	368 200 451		SCHILD		LABEL	PLAQUE	CALCOMANIA

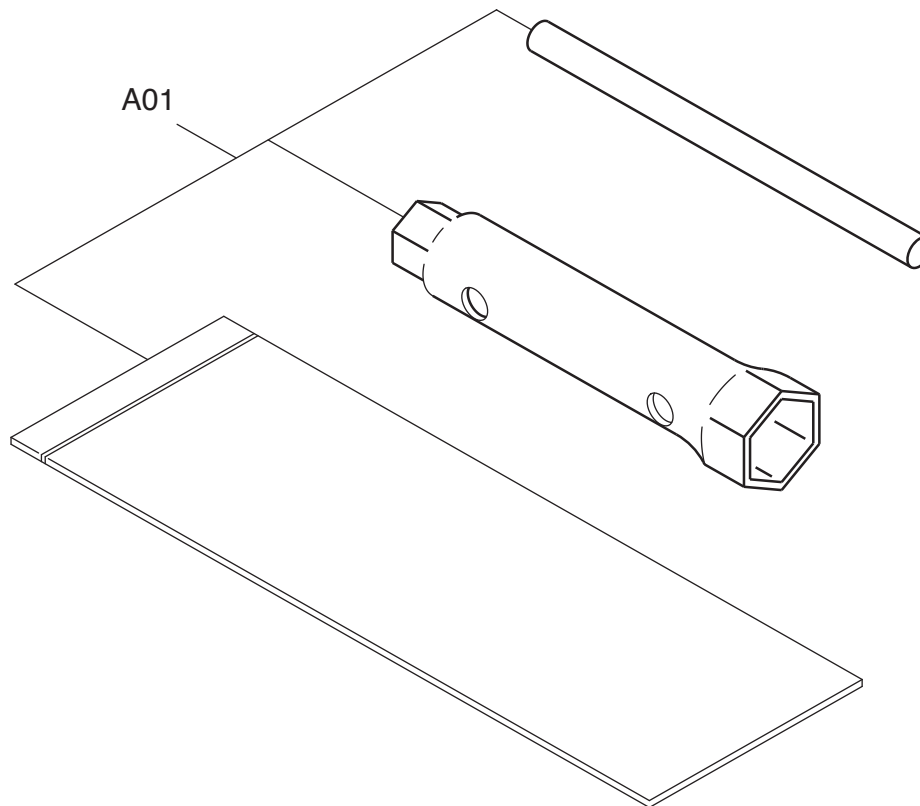

GE-4300 L



Seite / Page	Pos.	GE-4300 L	Teil-Nr. Part No. No. de pièce No. de pieza	Hinweise Notes Renseign. Nota	Bezeichnung	Spezifikation Specification	Description	Désignation	Denominación
13	A01	1	368 903 010		WERKZEUGSATZ		ACCESSORY TOOL KIT	OUTILS CPL	HERRAMIENTAS CPL.

1	Kurbelgehäuse, Zylinder	Crankcase, cylinder	Carter-vilebrequin, cylindre	Carter cigüeñal, cilindro
2	Kurbelwelle, Kolben	Crankshaft, piston	Vilebrequin, piston	Cigüeñal, pistón
3	Ventile, Luftfilter, Schalldämpfer	Valves, air cleaner, muffler	Soupapes, filtre à air, pot d'échappement	Válvulas, filtro de aire, silenciador
4	Reglerhebel	Governor lever	Levier régulateur	Palanca regulador
5	Anwerfvorrichtung, Ventilatorgehäuse	Starter, blower housing	Dispositivo de démarrage, carter de ventilateur	Dispositivo de arranque, carcasa del ventilador
6	Zündung, Ölsensor	Ignition, oil sensor	Bobine d'allumage, capteur d'huile	Bobina encendido, sensor de aceite
7	Vergaser	Carburetor	Carburateur	Carburador
8	Rotor, Stator	Rotor, stator	Rotor, stator	Rotor, estador
9	Rahmen	Frame	Cadre	Marko
10	Frontblende	Front panel	Panneau frontal	Panel frontal
11	Gehäuse	Housing	Carter	Caja
12	Kraftstofftank	Fuel tank	Reservoir d'essence	Depósito de combustible
13	Werkzeug	Tool set	Outils	Herramientas

	Zeichenerklärung	Key to symbols	Légende	Explicación de símbolos
⇒ 1999999 2000000 ⇒ 2003.04 ⇒ TI 2003/07 Acc. = { m Corr.	Produktion bis Serien-Nr. Neues Teil ab Serien-Nr. Neues Teil ab Jahr / Monat Siehe Technische Information Jahr / Nr. Zubehör (nicht im Lieferumfang) Keine Serienausführung, jedoch verwendbar Beinhaltet Positions-Nr. Meterware Druckfehlerberichtigung	Production to serial number New part from serial number New part from Year / Month See Technical Information Year / No. Accessories (not included in the delivery inventory) No standard execution, may be used Contains item number Sold by the meter Error correction	Production jusqu'à n° de série Nouveau pièce à partir du n° de série Nouveau pièce à partir de année / mois Voir information technique année / n° Accessoires (non compris dans la livraison) Aucune exécut. en série, cependant utilisable contient n° de numéro Au mètre Rectification d'erreurs	Producción hasta N° de serie Pieza nueva a partir de N° de serie Pieza nueva a partir de año / mes Véase inform. técnico año / N° Accesorios (no incluido en la extensión del suministro) No es de serie, pero sirve Contiene pos N° Por metro Fe de erratas
	Änderungen vorbehalten	Specifications subject to change without notice	Changements sans préavis	Mejoras constructivas sin previo aviso