

# Spare Parts List

2006-05

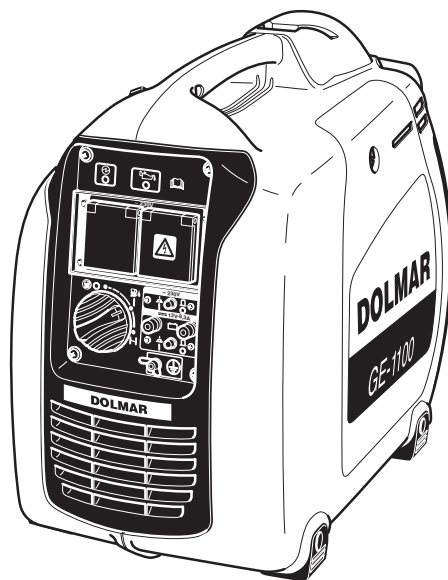

**GE-1100**

---

**DOLMAR**



A member of the *Makita* Group

995 700 272 (DE, GB, FR, ES)

DOLMAR GmbH

Postfach 70 04 20

D-22004 Hamburg

Germany

GE-1100

1

Kurbelgehäuse, Zylinder  
Crankcase, cylinder  
Carter-vilebrequin, cylindre  
Carter cigüeñal, cilindro

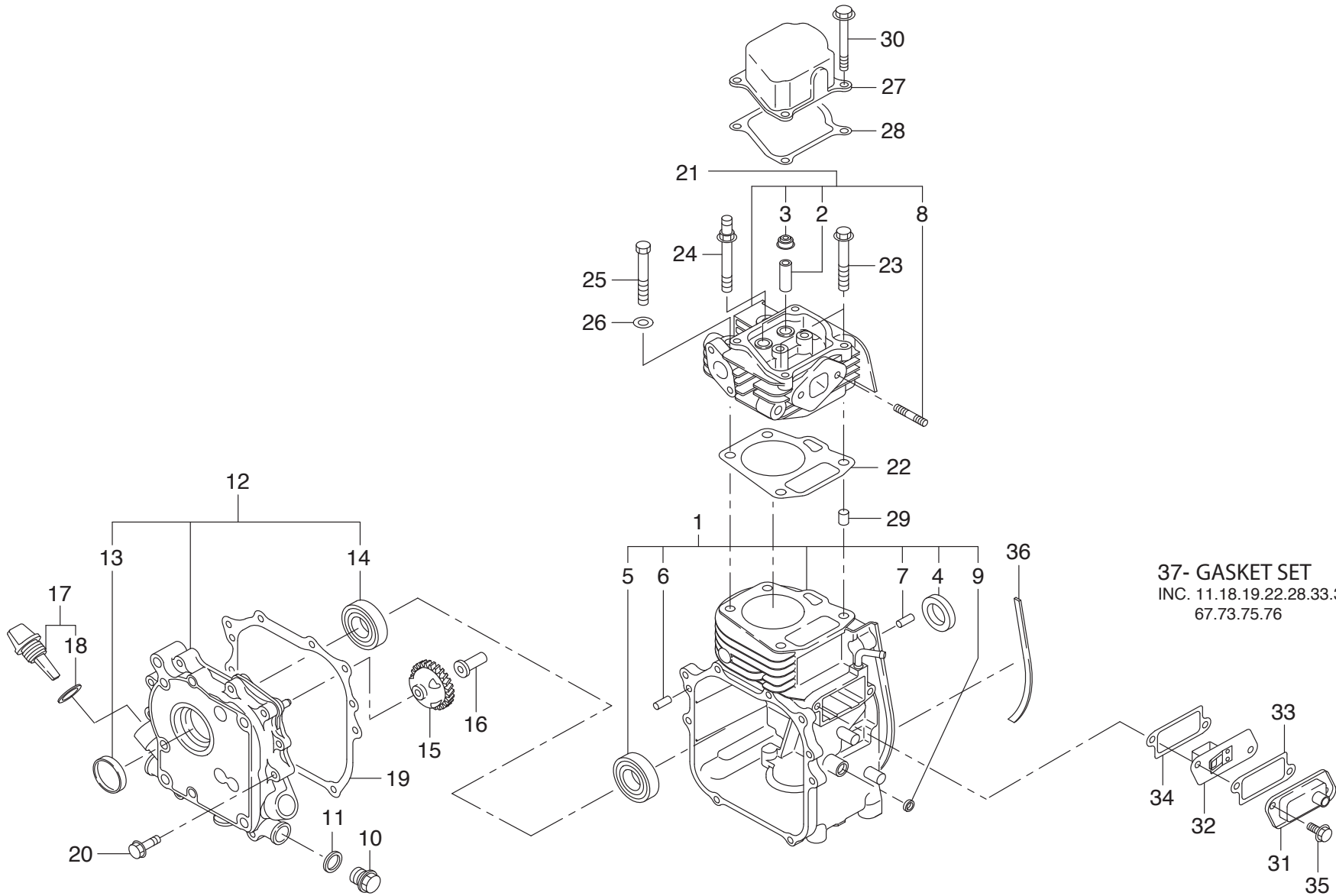

**GE-1100**



Seite / Page	Pos.	GE-1100	Teil-Nr. Part No. No. de pièce No. de pieza	Hinweise Notes Renseign. Nota	Bezeichnung	Spezifikation Specification	Description	Désignation	Denominación
1	1	1	368 101 030		KURBELGEHÄUSE KPL.		CRANKCASE CPL.	CARTER-VILEBREQUIN CPL.	CARTER CIGÜEÑAL CPL.
1	2	2	368 142 020		VENTILFÜHRUNG	5.5DX9.5DX27L	VALVE GUIDE	GUIDE-SOUPAPE	GUÍA VÁLVULA
1	3	1	368 160 100		DICHTUNG	5.5DX9.5DX15DX7.8B	GASKET	JOINT	JUNTA
1	4	1	368 020 007		RADIALDICHRING	20DX32DX6B	OIL SEAL	JOINT RADIAL	JUNTA RADIAL
1	5	1	368 020 014		KUGELLAGER	20DX42DX12B	BALL BEARING	ROULEMENT A BILLES	RODAMIENTO DE BOLAS
1	6	2	388 006 002		FÜHRUNGSSTIFT		DOWEL PIN	GOUPILLE	PERNO
1	7	2	368 150 110		ROHR	10.3DX8.5DX14L	PIPE KNOCK	TUBE	CONDUCTO
1	8	2	368 506 042		STIFTSCHRAUBE		STUD	GOUJON FILETÉ	PRISIONERO
1	9	1	381 006 002		RADIALDICHRING	6DX10DX2.5B	OIL SEAL	JOINT RADIAL	JUNTA RADIAL
1	10	1	368 114 003		STOPFEN	M14X1.5X20DX12L	PLUG	BOUCHON	TAPON
1	11	1	368 114 002		DICHTUNG	14.1DX19DX2.3T	GASKET	JOINT	JUNTA
1	12	1	368 112 012		ABDECKUNG KPL.		MAINBEARING COVER CPL.	COUVERCLE CPL.	CUBIERTA CPL.
1	13	1	368 171 020		GUMMISTOPFEN		PLUG, RUBBER	BOUCHON	TAPON
1	14	1	368 020 014		KUGELLAGER	20DX42DX12B	BALL BEARING	ROULEMENT A BILLES	RODAMIENTO DE BOLAS
1	15	1	368 450 030		REGLER KPL., GETRIEBE	44DX20T N=26	GOVERNOR GEAR CPL.	RÉGULATEUR, TRANSMISSION CPL.	ENGRANAJE REGULADOR CPL.
1	16	1	368 419 010		REGLER, HÜLSE	6DX9DX16DX26L	GOVERNOR SLEEVE	RÉGULATEUR, DOUILLE	MANGUITO REGULADOR
1	17	1	368 636 010		ÖLPEILSTAB KPL.	M18X1.5 L=38+18	OIL GAUGE CPL.	GAUGE D'HUILE CPL.	INDICADOR DEL NIVEL DE ACEITE CPL.
1	18	1	367 316 002		DICHTUNG	16DX23X1.2T	GASKET	JOINT	JUNTA
1	19	1	368 160 030		DICHTUNG		GASKET	JOINT	JUNTA
1	20	8	368 006 010		BOLZEN		BOLT	BOULON	BULÓN
1	21	1	368 130 030		ZYLINDERKOPF KPL.		CYLINDER HEAD CPL.	CULASSE CPL.	CULATA CPL.
1	22	1	368 150 011		DICHTUNG		GASKET	JOINT	JUNTA
1	23	2	368 008 021		BOLZEN		BOLT	BOULON	BULÓN
1	24	1	368 008 030		BOLZEN		BOLT	BOULON	BULÓN
1	25	1	368 008 042		BOLZEN		BOLT	BOULON	BULÓN
1	26	1	388 008 021		SCHEIBE		WASHER	RONDELLE	ARANDELA
1	27	1	368 155 010		ABDECKUNG F.KIPPHEBEL		ROCKER COVER	CAPOT POUR CULBUTEUR	TAPA DE BALANCINES CPL
1	28	1	368 160 040		DICHTUNG		GASKET	JOINT	JUNTA
1	29	2	368 150 110		ROHR	10.3DX8.5DX14L	PIPE KNOCK	TUBE	CONDUCTO
1	30	4	368 006 042		BOLZEN		BOLT	BOULON	BULÓN
1	31	1	368 143 010		ABDECKUNG KPL.		COVER CPL.	COUVERCLE CPL.	TAPA CPL.
1	32	1	368 144 010		PLATTE KPL.		PLATE CPL.	PLAQUE CPL.	PLACA CPL.
1	33	1	368 160 061		DICHTUNG		GASKET	JOINT	JUNTA
1	34	1	368 160 070		DICHTUNG		GASKET	JOINT	JUNTA
1	35	2	383 006 002		BOLZEN	M6X1.0X14DX12L	BOLT	BOULON	BULÓN
1	36	1	368 583 170		SCHAUMGUMMI		SPONGE	ÉPONGE	ESPONJA
1	37	1	368 990 021		DICHTUNGEN, SATZ		GASKET, SET	JOINT, JEU	JUNTA, JUEGO

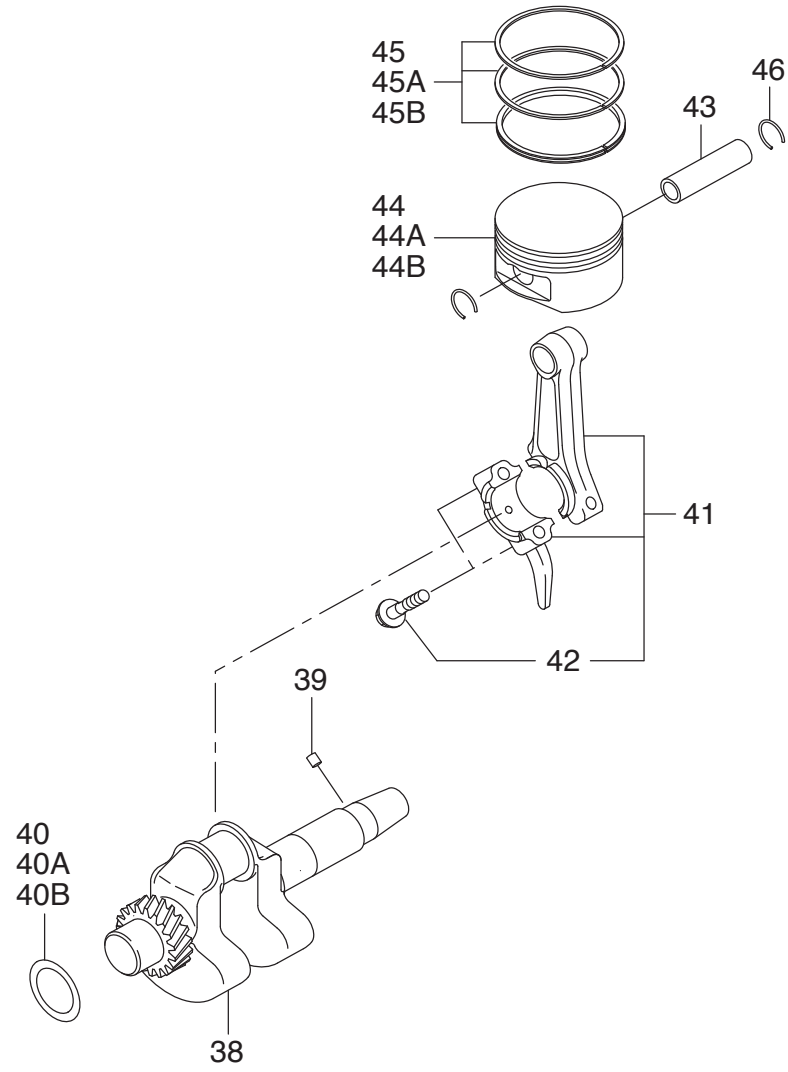

## GE-1100



Seite / Page	Pos.	GE-1100	Teil-Nr. Part No. No. de pièce No. de pieza	Hinweise Notes Renseign. Nota	Bezeichnung	Spezifikation Specification	Description	Désignation	Denominación
2	38	1	368 205 011		KURBELWELLE KPL.		CRANKSHAFT CPL.	VILEBREQUIN CPL.	CIGÜEÑAL CPL.
2	39	1	368 004 001		FÜHRUNGSSTIFT		DOWEL PIN	GOUPILLE	PERNO
2	40	1	368 020 010		DISTANZSTÜCK	20.5DX28DX0.8T	SPACER	PIECE DISTANCE	ANILLO SEPARADOR
2	40A	1	368 020 011		DISTANZSTÜCK	20.5DX28DX1.0T	SPACER	PIECE DISTANCE	ANILLO SEPARADOR
2	40B	1	368 020 012		DISTANZSTÜCK	20.5DX28DX1.2T	SPACER	PIECE DISTANCE	ANILLO SEPARADOR
2	41	1	368 225 013		PLEUELSTANGE KPL.	66CDX18B 21D-11D	CONNECTING ROD ASSY.	BIELLE	BIELA
2	42	2	388 230 010		BOLZEN	M5X0.8X11DX25L	BOLT	BOULON	BULÓN
2	43	1	368 233 010		KOLBENBOLZEN	11DX8DX40L	PISTON PIN	AXE DE PISTON	PERNO DE PISTÓN
2	44	1	383 234 013		KOLBEN	STD(51DX31H)	PISTON	PISTON	PISTON
2	44A	1	368 234 023		KOLBEN		PISTON	PISTON	PISTON
2	44B	1	381 234 033		KOLBEN		PISTON	PISTON	PISTON
2	45	1	368 235 010		KOLBENRING-SATZ	STD(51D)	PISTON RING SET	JEU DE SEGMENTS DE PISTON	JUEGO DE SEGMENTOS DEL PISTÓN
2	45A	1	368 235 020		KOLBENRING-SATZ	0.25 OVER SIZE	PISTON RING SET	JEU DE SEGMENTS DE PISTON	JUEGO DE SEGMENTOS DEL PISTÓN
2	45B	1	368 235 030		KOLBENRING-SATZ	0.50 OVER SIZE	PISTON RING SET	JEU DE SEGMENTS DE PISTON	JUEGO DE SEGMENTOS DEL PISTÓN
2	46	2	368 511 001		SPRENGRING	12DX1D	CLIP	ANNEAU RESSORT	ANILLO ELÁSTICO

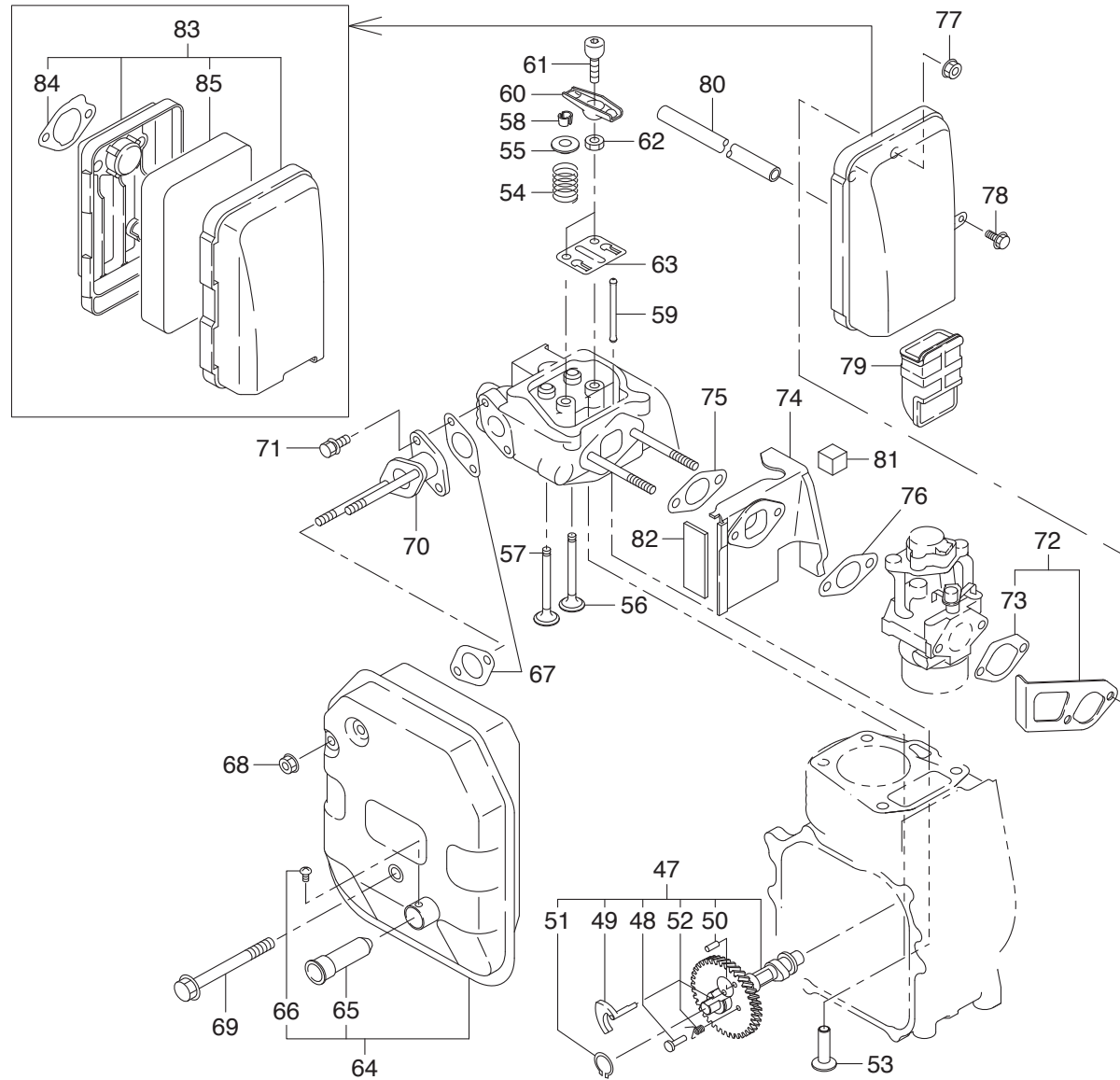

**GE-1100**



Seite / Page	Pos.	GE-1100	Teil-Nr. Part No. No. de pièce No. de pieza	Hinweise Notes Renseign. Nota	Bezeichnung	Spezifikation Specification	Description	Désignation	Denominación
3	47	1	368 317 012		ACHSE F.NOCKENRAD		CAM GEAR SHAFT	AXE DE PIGNON DE DISTRIBUTION	EJE D. PIÑÓN D. ÁRB. DE LEV.
3	48	1	368 386 012		STIFT	3.8DX7.5DX14L	PIN	GOUPILLE	PERNO
3	49	1	388 364 010		ENTRIEGELUNGSHEBEL		RELEASE LEVER	LEVIER DE DÉBLOQUAGE	PALANCA DE DESBLOQUEO
3	50	1	368 190 410		STIFT		PIN	GOUPILLE	PERNO
3	51	1	368 151 700		SICHERUNGSRING		SNAP RING	CIRCLIP	ANILLO SEGURIDAD
3	52	1	368 387 012		FEDER		SPRING	RESSORT	MUELLE
3	53	2	368 333 010		VENTILSTÖBEL	17DX8DX32L	TAPPET	POUSSOIR DE SOUPAPE	LEVANTAVÁLVULAS
3	54	2	381 336 010		VENTILFEDER		VALVE SPRING	RESSORT DE VANNE	MUELLE DE VÁLVULA
3	55	2	368 337 020		FEDERTELLER		SPRING RETAINER	CUVETTE DE RESSORT	CAJA DE RESORTE
3	56	1	368 334 010		EINLASSVENTIL	21DX5.5DX63.6L	INTAKE VALVE	VALVE D'ADMISSION	VÁLVULA DE ADMISIÓN
3	57	1	368 335 010		AUSLASSVENTIL	18DX5.5DX63.6L	EXHAUST VALVE	SOUPAPE D'EMISSION	VÁLVULA DE ESCAPE
3	58	4	383 100 300		BUCHSE		COLLET	DOUILLE	ENCHUFE
3	59	2	368 353 010		STÖBELSTANGE		PUSH ROD	TIGE DE CULBUTEUR	EMPUJADOR
3	60	2	368 360 030		KIPPHEBEL KPL.		ROCKER ARM ASSY.	CULBUTEUR CPL.	GRUPO DEL BALANCÍN CPL.
3	61	2	368 358 010		BOLZEN		BOLT	BOULON	BULÓN
3	62	2	368 006 009		MUTTER	M6X0.75X5.1H	NUT	ECROU	TUERCA
3	63	1	381 365 010		LEITBLECH		GUIDE PLATE	PLAQUE DE GUIDAGE	PLACA GUÍA
3	64	1	368 302 012		SCHALLDÄMPFER KPL.		MUFFLER CPL.	POT D'ECHAPPEMENT CPL.	SILENCIOSO CPL.
3	65	1	381 376 010		FUNKENSCHUTZSIEB		SPARK ARRESTER	TAMIS CONTRE ÉTINCELLES	TAMIZ PARACHISPAS
3	66	1	368 004 006		SCHNEIDSCHRAUBE	M4X6L	TAPPING SCREW	VIS DE COUPE	TORNILLO DE ROSCA CORTANTE
3	67	2	368 352 040		DICHTUNG KPL.		GASKET CPL.	JOINT CPL.	JUNTA CPL.
3	68	2	383 006 003		MUTTER	M6	NUT	ECROU	TUERCA
3	69	1	368 008 011		BOLZEN	M8X1.25X80L	BOLT	BOULON	BULÓN
3	70	1	368 341 011		AUSLASS		EXHAUST PIPE	TUYAU D'ÉVACUATION	CONDUCTO DE SALIDA
3	71	2	368 140 616		SCHRAUBE MIT SCHEIBE		BOLT & WASHER ASSY.	VIS AVEC RONDELLE	TORNILLO CON ARANDELA
3	72	1	368 329 040		ABBLENDBLECH KPL.		BAFFLE CPL.	TÔLE CPL.	CHAPA CPL.
3	73	1	368 467 010		DICHTUNG		GASKET	JOINT	JUNTA
3	74	1	368 329 030		ABSCHIRMBLECH		INSULATOR	TÔLE DE DERIVATION	CHAPA DE DISIPACIÓN
3	75	1	368 359 020		DICHTUNG		GASKET	JOINT	JUNTA
3	76	1	368 350 010		DICHTUNG		GASKET	JOINT	JUNTA
3	77	2	368 380 600		MUTTER	M6	NUT	ECROU	TUERCA
3	78	1	368 006 018		BOLZEN	M6X1.0X14DX18L	BOLT	BOULON	BULÓN
3	79	1	368 321 010		KANAL		DUCT	CONDUIT	CONDUCTO
3	80	1	368 108 000		SCHLAUCH	1 m	RUBBER PIPE	TUYAU SOUPLE	TUBO FLEXIBLE
3	81	1	368 583 151		SCHAUMGUMMI		SPONGE	ÉPONGE	ESPONJA
3	82	1	368 583 211		SCHAUMGUMMI		SPONGE	ÉPONGE	ESPONJA
3	83	1	368 326 300		LUFTFILTER KPL.		AIR CLEANER ASSY.	FILTRE À AIR CPL.	FILTRO DE AIRE CPL.
3	84	1	368 360 041		DICHTUNG	T=0.3 27D 6.5DX42P	GASKET	JOINT	JUNTA
3	85	1	368 326 310		LUFTFILTERELEMENT		ELEMENT	FILTRE À AIR	FILTRO DE AIRE

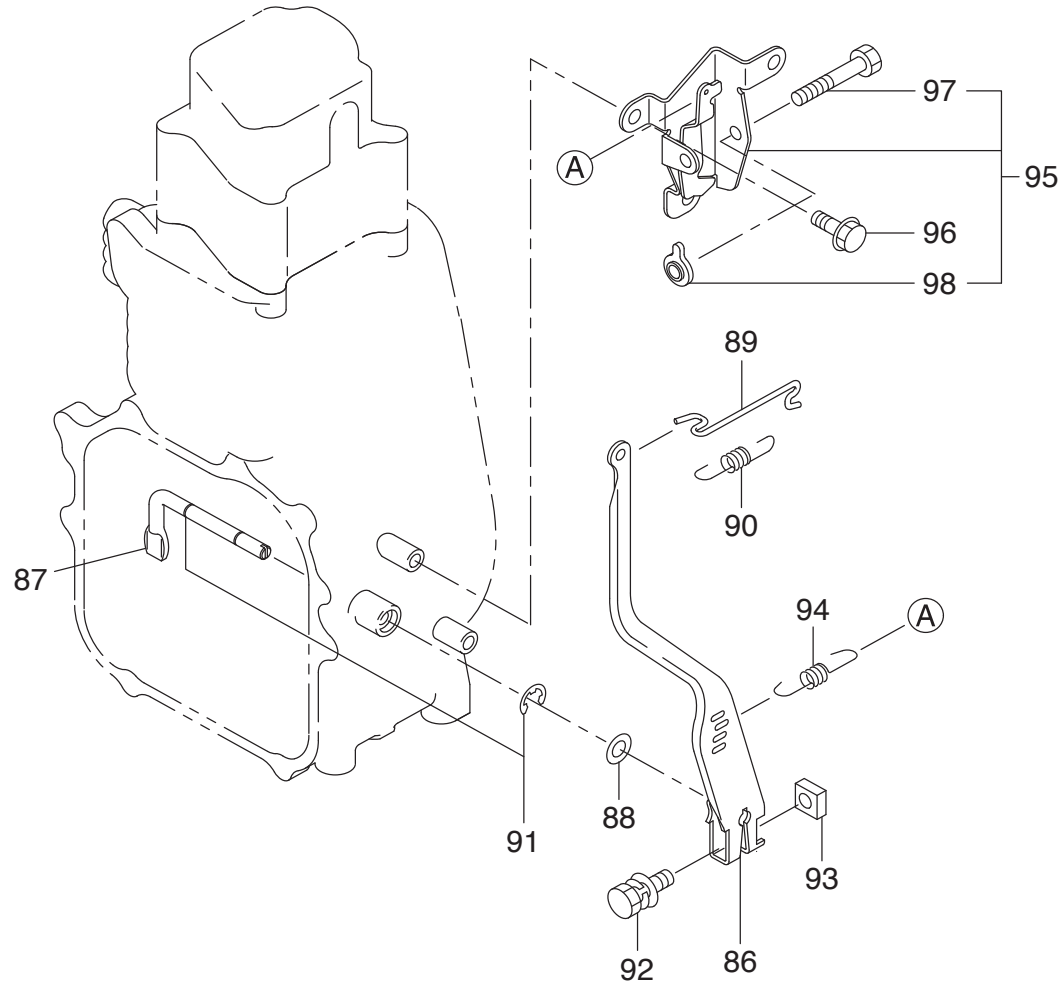



**GE-1100**



Seite / Page	Pos.	GE-1100	Teil-Nr. Part No. No. de pièce No. de pieza	Hinweise Notes Renseign. Nota	Bezeichnung	Spezifikation Specification	Description	Désignation	Denominación
4	86	1	368 423 022		REGLERHEBEL KPL.		GOVERNOR LEVER CPL.	LEVIER RÉGULATEUR CPL.	PALANCA REGULADOR CPL.
4	87	1	368 422 010		REGLERWELLE		GOVERNOR SHAFT	ARBRE RÉGULATEUR	EJE REGULADOR
4	88	1	368 006 037		DISTANZSTÜCK		SPACER	PIECE DISTANCE	ANILLO SEPARADOR
4	89	1	368 427 011		REGLERSTANGE KPL.		GOVERNOR ROD CPL.	BARRE RÉGULATEUR CPL.	VARILLA REGULADOR CPL.
4	90	1	368 428 030		FEDER		SPRING	RESSORT	MUELLE
4	91	2	368 130 500		SPRENGRING		CLIP	ANNEAU RESSORT	ANILLO ELÁSTICO
4	92	1	368 140 625		SCHRAUBE MIT SCHEIBE		BOLT & WASHER ASSY.	VIS AVEC RONDELLE	TORNILLO CON ARANDELA
4	93	1	368 606 002		MUTTER	M6X1.0X4.9H	NUT	ECROU	TUERCA
4	94	1	368 425 011		FEDER		SPRING	RESSORT	MUELLE
4	95	1	368 462 000		HALTERUNG		BRACKET	FIXATION	SOPORTE
4	96	2	368 006 001		BOLZEN	M6X1.0X14DX8L	BOLT	BOULON	BULÓN
4	97	1	368 650 635		BOLZEN		BOLT	BOULON	BULÓN
4	98	1	368 490 020		EINSTELLMUTTER		ADJUSTMENT NUT	ECROU DE REGLAGE	TUERCA REGLAJE

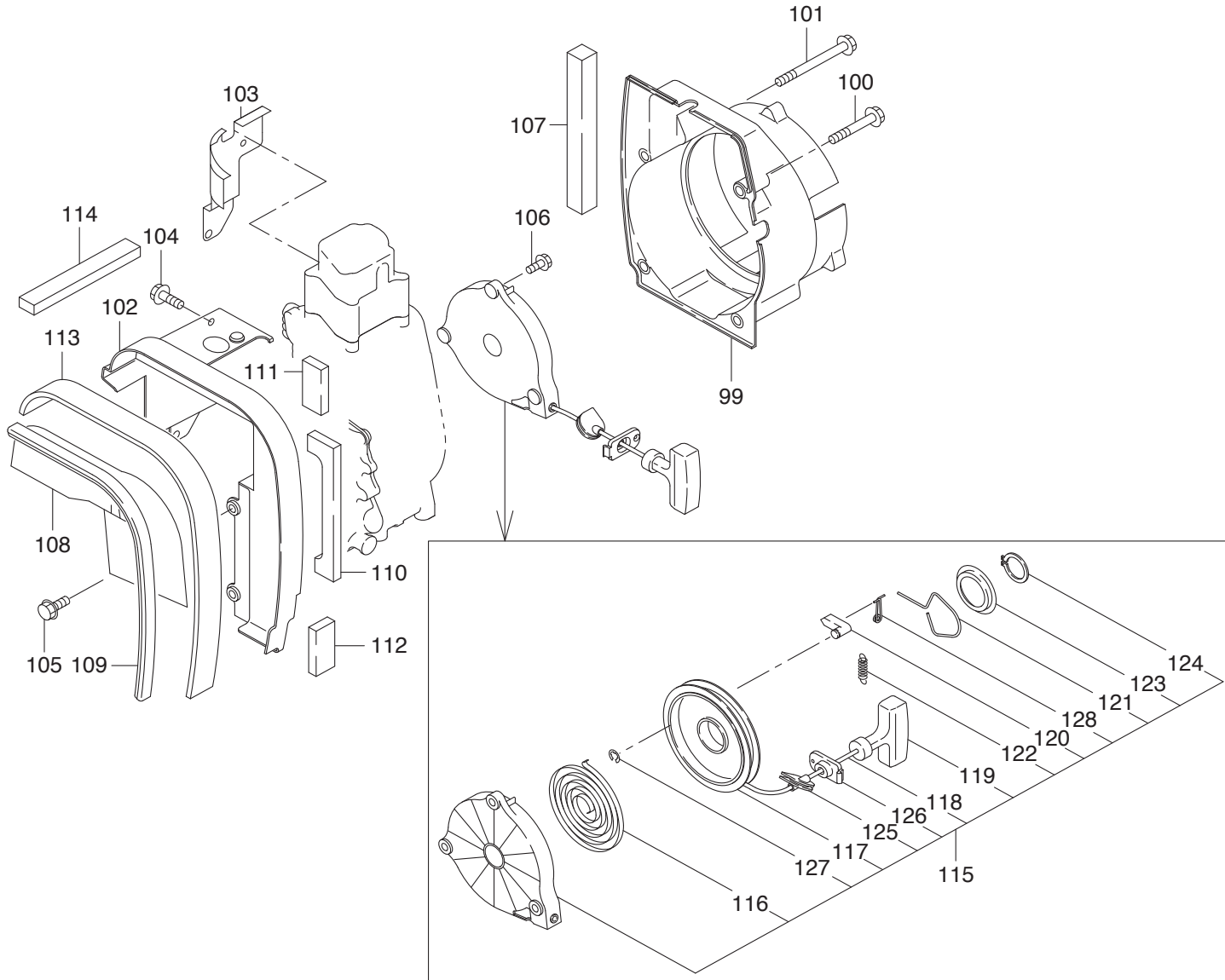

## GE-1100



Seite / Page	Pos.	GE-1100	Teil-Nr. Part No. No. de pièce No. de pieza	Hinweise Notes Renseign. Nota	Bezeichnung	Spezifikation Specification	Description	Désignation	Denominación
5	99	1	368 512 010		VENTILATORGEHÄUSE		BLOWER HOUSING	CARTER DE VENTILATEUR	CARCASA DEL VENTILADOR
5	100	1	368 008 016		BOLZEN		BOLT	BOULON	BULÓN
5	101	3	381 008 030		BOLZEN		BOLT	BOULON	BULÓN
5	102	1	368 536 010		ABDECKPLATTE KPL.		CYLINDER BAFFLE CPL.	PLAQUE DE RECOUVREMENT CPL.	PLACA COBERTORA CPL.
5	103	1	368 536 030		ABDECKPLATTE		CYLINDER BAFFLE(E/G)	PLAQUE DE RECOUVREMENT	PLACA COBERTORA
5	104	3	368 008 015		BOLZEN	M8X12L	BOLT	BOULON	BULÓN
5	105	1	383 006 002		BOLZEN	M6X1.0X14DX12L	BOLT	BOULON	BULÓN
5	106	3	368 006 014		BOLZEN	M6X18L	BOLT	BOULON	BULÓN
5	107	1	368 512 030		ABDICHTUNG		GASKET	JOINT	JUNTA
5	108	1	368 536 062		ISOLIERUNG		INSULATION	ISOLATION	AISLAMIENTO
5	109	1	368 536 050		ABDICHTUNG		GASKET	JOINT	JUNTA
5	110	1	368 536 090		ABDICHTUNG		GASKET	JOINT	JUNTA
5	111	1	368 536 100		ABDICHTUNG		GASKET	JOINT	JUNTA
5	112	1	368 536 100		ABDICHTUNG		GASKET	JOINT	JUNTA
5	113	1	368 583 230		SCHAUMGUMMI		SPONGE	ÉPONGE	ESPONJA
5	114	1	368 536 080		ABDICHTUNG		GASKET	JOINT	JUNTA
5	115	1	368 502 211		STARTER KPL.		RECOILSTARTER ASSY.	STARTER CPL.	ARRANQUE CPL.
5	116	1	368 502 240		FEDER		SPRING	RESSORT	MUELLE
5	117	1	368 502 220		SEILTROMMEL		REEL	TAMBOUR DE CÂBLE	TAMBOR PARA CUERDA
5	118	1	368 502 330		ANWERFSEIL		STARTER ROPE	CÂBLE DE DÉMARRAGE	CORDÓN DE ARRANQUE
5	119	1	382 500 211		ANWERFGRIFF		STARTER KNOB	POIGNEE DE LANCEMENT	TIRADOR DE ARRANQUE
5	120	1	368 502 230		SPERRKLINKE		RATCHET	CLIQUET D'ARRÊT	TRINQUETE
5	121	1	368 502 260		FEDER		FRICTION SPRING	RESSORT	MUELLE
5	122	1	368 502 270		FEDER		SPRING	RESSORT	MUELLE
5	123	1	368 502 251		REIBSCHEIBE		FRICTION PLATE	DISCQUE DE FRICTION	RODAJA DE FRICCION
5	124	1	368 502 310		SICHERUNGSRING		RETAINING RING	CIRCLIP	ANILLO SEGURIDAD
5	125	1	368 561 010		SEILFÜHRUNG		ROPE GUIDE	GUIDAGE CÂBLE	CABLE GUÍA
5	126	1	368 530 010		FÜHRUNG KPL.		GUIDE CPL.	GUIDE CPL.	GUÍA CPL.
5	127	1	368 502 290		SICHERUNGSRING		RETAINING RING	CIRCLIP	ANILLO SEGURIDAD
5	128	1	368 502 280		KLINKENFÜHRUNG		RACHET GUIDE	GUIDE À CLIQUET	GUÍA DE TRINQUETE

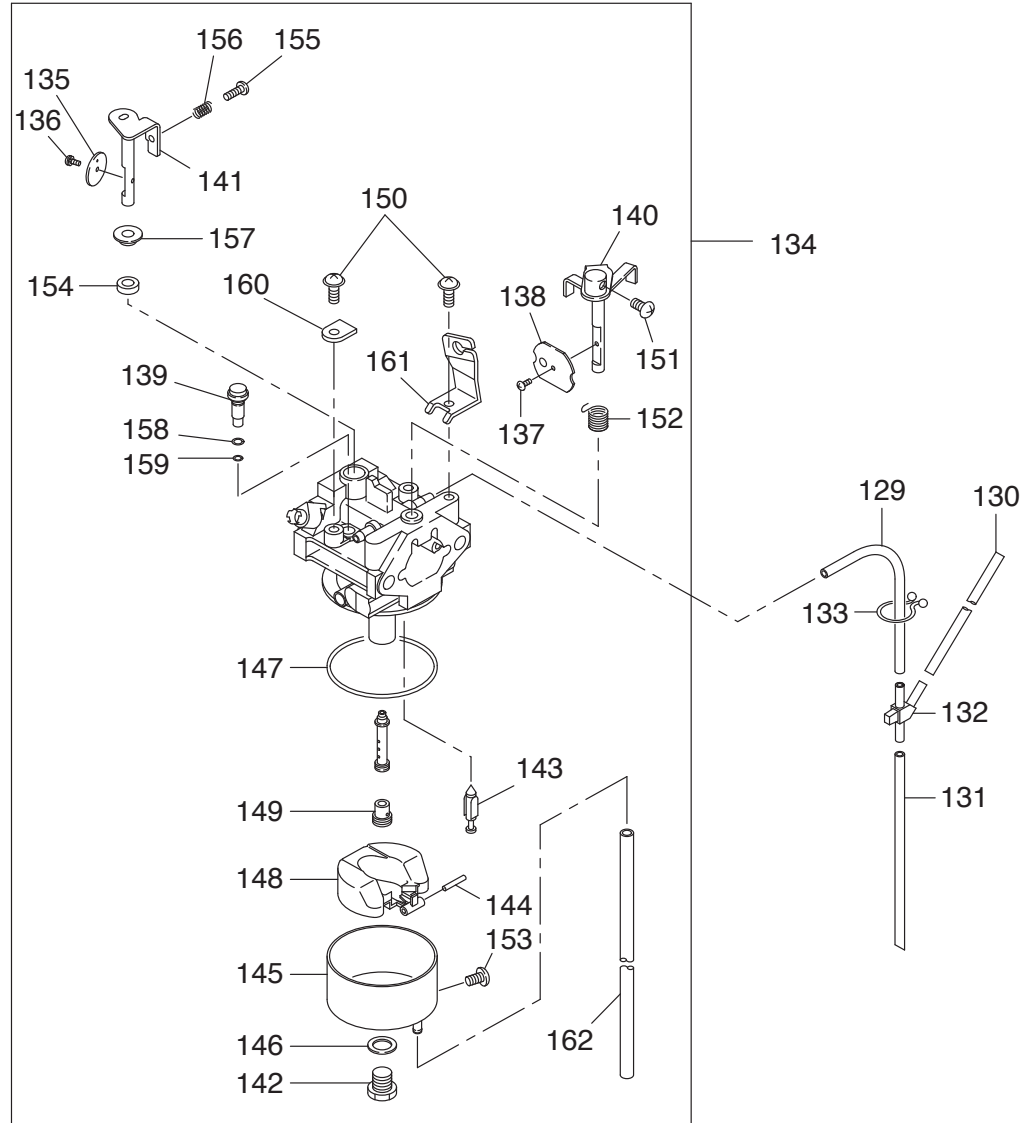

GE-1100

**DOLMAR**  

Seite / Page	Pos.	GE-1100	Teil-Nr. Part No. No. de pièce No. de pieza	Hinweise Notes Renseign. Nota	Bezeichnung	Spezifikation Specification	Description	Désignation	Denominación
6	129	1	368 093 000		SCHLAUCH		VINYL PIPE	TUBE	TUBO
6	130	1	368 093 000		SCHLAUCH		VINYL PIPE	TUBE	TUBO
6	131	1	368 093 000		SCHLAUCH		VINYL PIPE	TUBE	TUBO
6	132	1	368 671 010		Y-ANSCHLUSS		Y CONNECTOR	CONNECTEUR Y	CONECTOR Y
6	133	1	368 900 002		VERSCHLUSS KPL.		PURSE LOCK ASSY.	OBTURATEUR CPL.	CIERRE CPL.
6	134	1	368 623 012		VERGASER KPL.		CARBURETOR ASSY	CARBURATEUR CPL.	CARBURADOR CPL.
6	135	1	383 625 350		DROSSELKLAPPE		THROTTLE VALVE	CLAPET D'ÉTRANGLEMENT	VÁLVULA REG.
6	136	1	368 624 550		SCHRAUBE		SCREW	VIS	TORNILLO
6	137	1	368 624 550		SCHRAUBE		SCREW	VIS	TORNILLO
6	138	1	368 625 250		CHOKEKLAPPE		CHOKE VALVE	CLAPET DE STARTER	TAPA DEL CHOKE
6	139	1	388 624 200		DÜSE		JET	BUSE	CHICLÉ
6	140	1	368 625 200		CHOKEHEBEL		CHOKE LEVER	LEVIER DE STARTER	PALANCA ESTRANGUL. AIRE
6	141	1	368 625 300		DROSSELWELLE		THROTTLE SHAFT	AXE CLAPET D'ÉTRANG.	EJE VÁLVULA REG.
6	142	1	368 623 550		BOLZEN		BOLT	BOULON	BULÓN
6	143	1	368 625 000		EINLASSNADEL KPL.		VALVE, INLET NEEDLE CPL.	POINTEAU D'ARRVÉE D'ESSENCE CPL.	AGUJA DE VÁLVULA CPL.
6	144	1	381 625 150		STIFT		PIN	GOUPILLE	PERNO
6	145	1	368 625 500		SCHWIMMERKÖRPER		FLOAT BODY	CORPS DU FLOTTEUR	CUERPO DEL FLOTADOR
6	146	1	368 623 500		DICHTUNG		GASKET	JOINT	JUNTA
6	147	1	368 625 400		ABDICHTUNG		PACKING	JOINT	JUNTA
6	148	1	381 625 050		SCHWIMMER KPL.		FLOAT CPL.	FLOTTEUR CPL.	FLOTADOR CPL.
6	149	1	368 624 000		DÜSE		JET	BUSE	CHICLÉ
6	150	2	368 624 560		SCHRAUBE		SCREW	VIS	TORNILLO
6	151	1	368 624 560		SCHRAUBE		SCREW	VIS	TORNILLO
6	152	1	381 624 450		FEDER		SPRING	RESSORT	MUELLE
6	153	1	368 626 610		SCHRAUBE		SCREW	VIS	TORNILLO
6	154	1	368 625 590		TÜLLE		BUSH	PASSE-FIL	BOQUILLA
6	155	1	368 623 530		STELLSCHRAUBE	M5	ADJUST SCREW	VIS DE REGLAGE	TORNILLO DE AJUSTE
6	156	1	368 624 450		FEDER		SPRING	RESSORT	MUELLE
6	157	1	368 625 600		HÜLSE		COLLAR	DOUILLE	CASQUILLO
6	158	1	381 624 500		O-RING		O RING	ANNEAU TORIQUE	ANILLO OBTURADOR
6	159	1	368 624 510		O-RING		O RING	ANNEAU TORIQUE	ANILLO OBTURADOR
6	160	1	368 625 630		PLATTE		PLATE	PLAQUE	PLACA
6	161	1	368 625 701		HALTERUNG		BRACKET	FIXATION	SOPORTE
6	162	1	368 625 670		SCHLAUCH		VYNYL PIPE	TUBE	TUBO

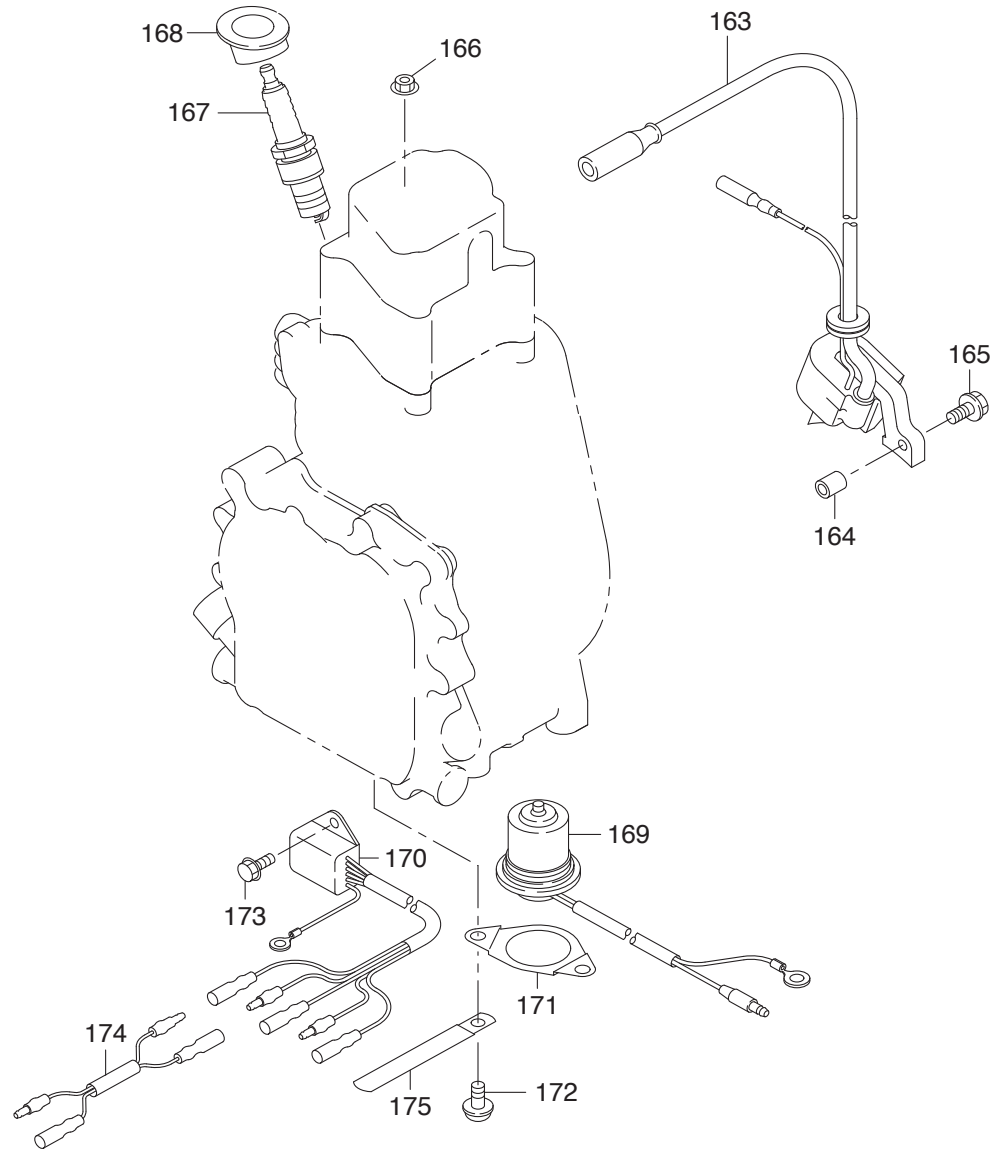

**GE-1100****DOLMAR**

Seite / Page	Pos.	GE-1100	Teil-Nr. Part No. No. de pièce No. de pieza	Hinweise Notes Renseign. Nota	Bezeichnung	Spezifikation Specification	Description	Désignation	Denominación
7	163	1	368 794 302		ZÜNDSPULE KPL.	MARK AH	IGNITION COIL CPL.	BOBINE D' ALLUMAGE CPL.	BOBINA DE ENCENDIDO CPL.
7	164	2	368 006 036		DISTANZSTÜCK		SPACER	PIECE DISTANCE	ANILLO SEPARADOR
7	165	2	368 140 645		SCHRAUBE MIT SCHEIBE		BOLT & WASHER ASSY.	VIS AVEC RONDELLE	TORNILLO CON ARANDELA
7	166	1	368 380 800		MUTTER		NUT	ECROU	TUERCA
7	167	1	368 014 038		ZÜNDKERZE	NGK BMR4A	SPARK PLUG	BOUGIE	BUIJA
7	168	1	368 755 010		TÜLLE		GROMMET	PASSE-FIL	CAPERUCITA
7	169	1	368 763 011		ÖLSENSOR		OIL SENSOR	CAPTEUR D'HUILE	SENSOR DE ACEITE
7	170	1	368 110 410		STEUERUNG, SCHWIMMER		FLOAT C/U	COMMANDE, FLOTTEUR	MANDO FLOTADOR
7	171	1	368 758 010		HALTERUNG, ÖLSENSOR		RETAINER, OIL SENSOR	FIXATION, CAPTEUR D'HUILE	FIXATION, SENSOR DE ACEITE
7	172	2	368 350 610		SCHRAUBE MIT SCHEIBE KPL.		SCREW & WASHER ASSY.	VIS AVEC RONDELLE CPL.	TORNILLO CON ARANDELA CPL.
7	173	1	383 006 002		BOLZEN	M6X1.0X14DX12L	BOLT	BOULON	BULÓN
7	174	1	368 795 911		KABELBAUM KPL.		OIL SENSOR HARNESS CPL.	FAISCEAU DE CÂBLES CPL.	MAZO DE CABLES CPL.
7	175	1	368 751 010		KLAMMER		CLAMP	CRAMPON	GRAPA

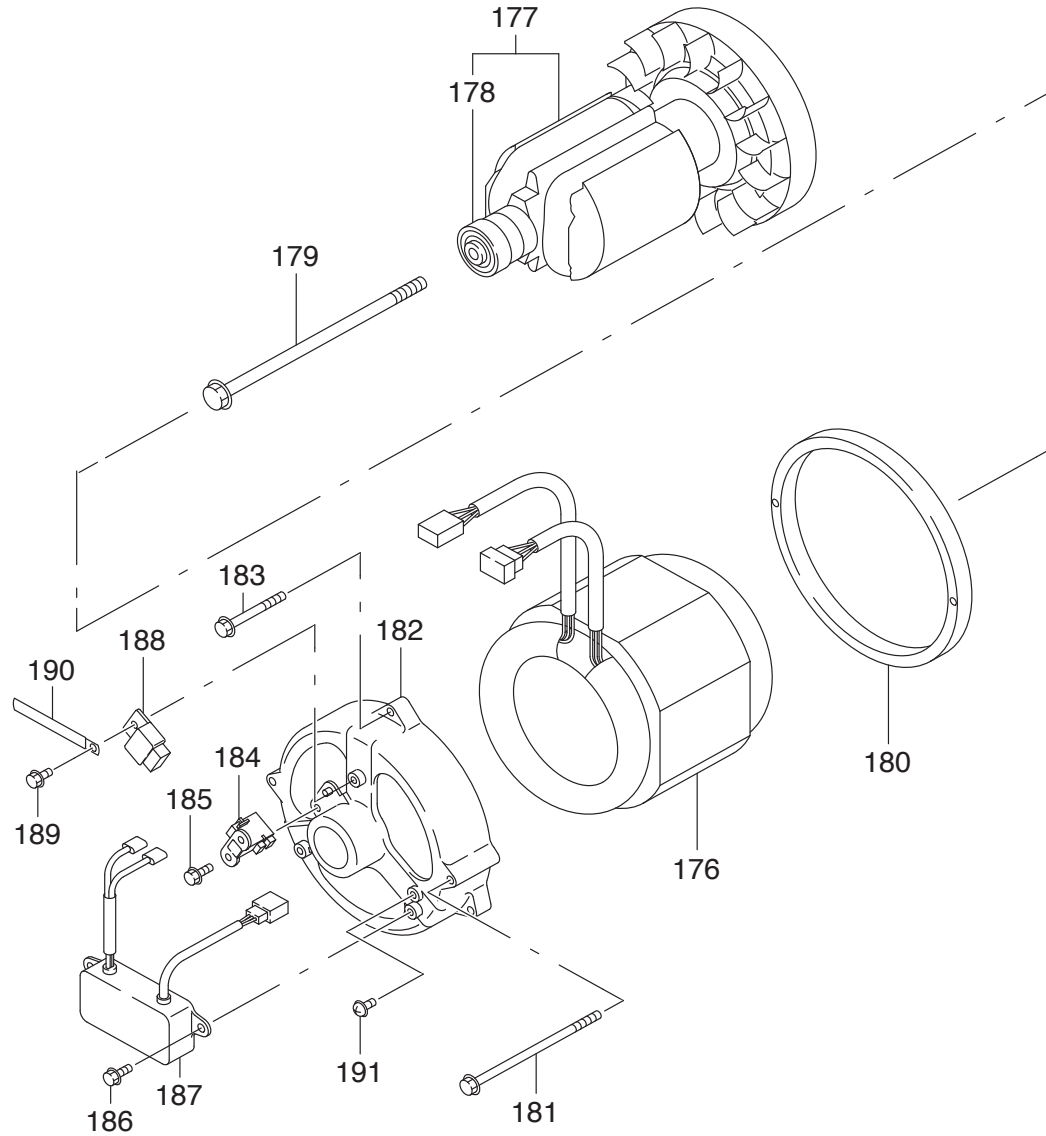



## GE-1100



Seite / Page	Pos.	GE-1100	Teil-Nr. Part No. No. de pièce No. de pieza	Hinweise Notes Renseign. Nota	Bezeichnung	Spezifikation Specification	Description	Désignation	Denominación
8	176	1	368 217 510		STATOR KPL.		STATOR CPL.	STATOR CPL.	ESTADOR CPL.
8	177	1	368 209 020		ROTOR KPL.		ROTOR CPL.	ROTOR CPL.	ROTOR CPL.
8	178	1	383 210 010		KUGELLAGER		BALL BEARING	ROULEMENT A BILLES	RODAMIENTO DE BOLAS
8	179	1	383 209 060		BOLZEN		BOLT	BOULON	BULÓN
8	180	1	388 209 070		RING		RING	BAGUE	ANILLO
8	181	2	381 209 050		BOLZEN		BOLT	BOULON	BULÓN
8	182	1	381 209 030		ABDECKUNG		COVER	COUVERCLE	CUBIERTA
8	183	3	388 209 040		BOLZEN		BOLT	BOULON	BULÓN
8	184	1	381 231 010		KOHLEBÜRSTE KPL.		BRUSH CPL.	CHARBON CPL.	ESCOBILLA CPL.
8	185	1	320 210 510		SCHRAUBE		SCREW	VIS	TORNILLO
8	186	2	320 210 510		SCHRAUBE		SCREW	VIS	TORNILLO
8	187	1	367 230 010		AUTOMATISCHER SPANNUNGSREGLER KPL.		AVR CPL.	REGULATEUR DE LA TENSION AUTOM. CPL.	REGULADOR AUTOM. DE LA TENSION CPL.
8	188	1	381 231 210		DIODE KPL.		DIODE CPL.	DIODE CPL.	DIODO CPL.
8	189	4	368 210 520		SCHRAUBE		SCREW	VIS	TORNILLO
8	190	3	368 210 600		KLAMMER		CLAMP	CRAMPON	GRAPA
8	191	1	368 210 530		SCHRAUBE		SCREW	VIS	TORNILLO

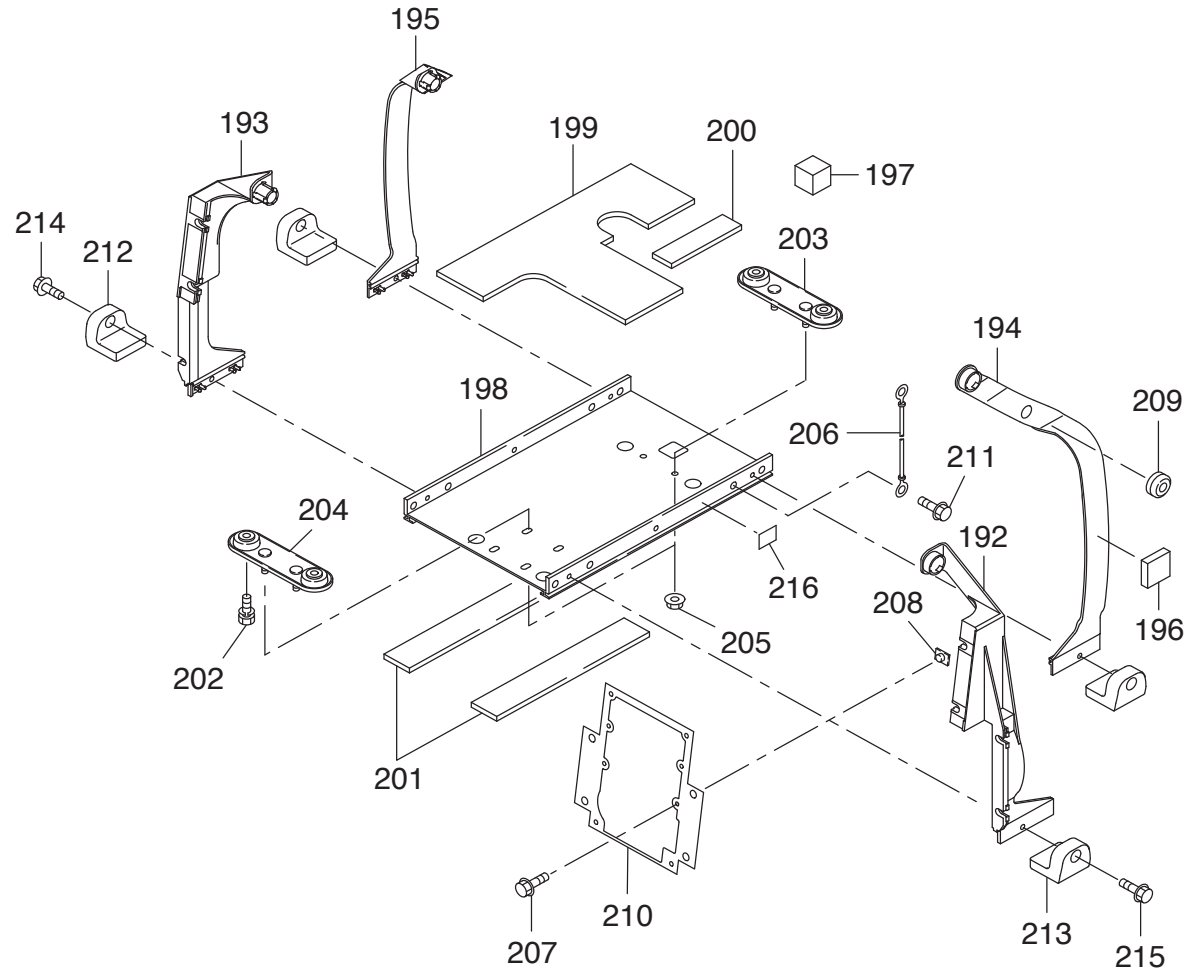

GE-1100

**DOLMAR**  

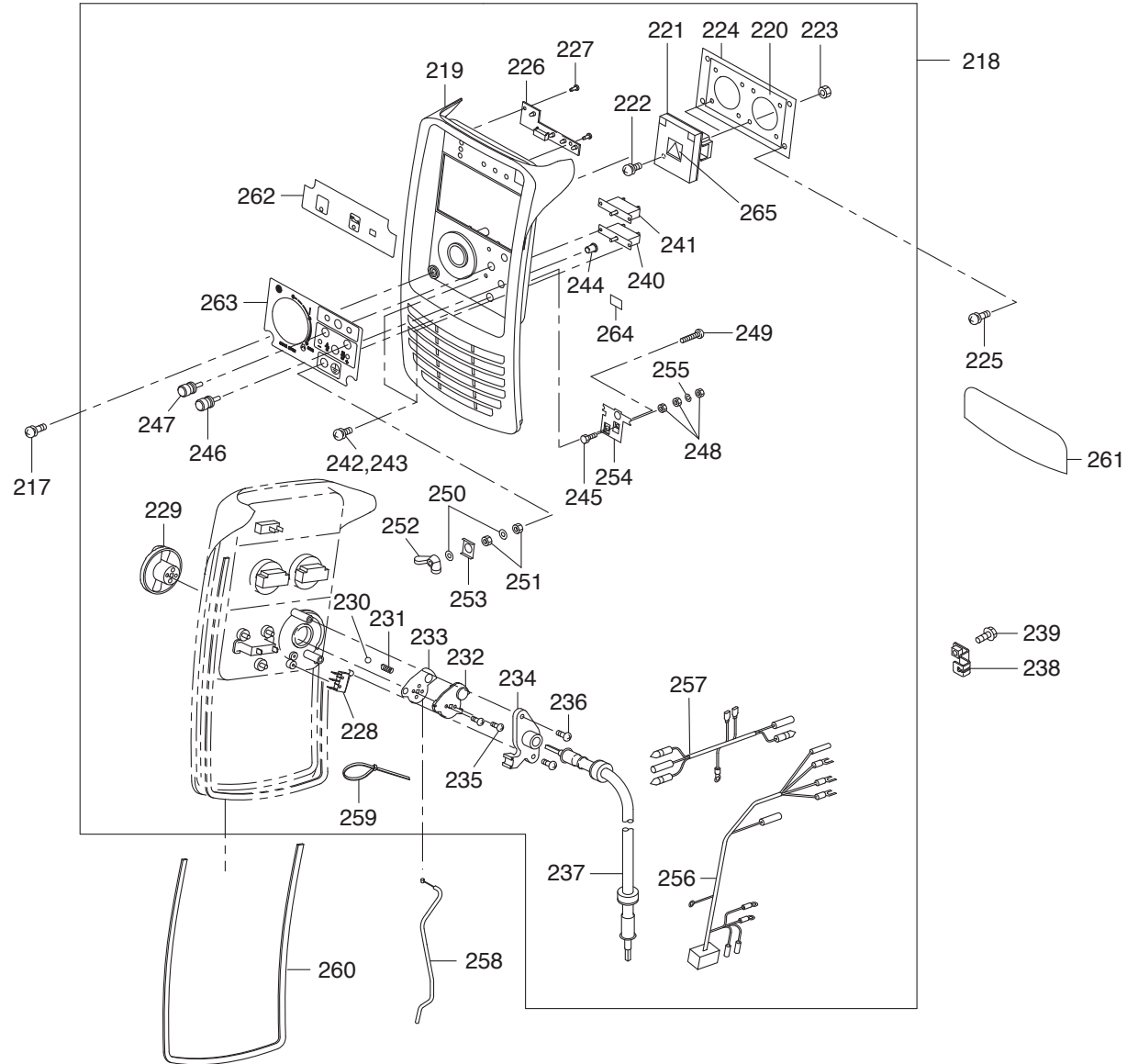

Seite / Page	Pos.	GE-1100	Teil-Nr. Part No. No. de pièce No. de pieza	Hinweise Notes Renseign. Nota	Bezeichnung	Spezifikation Specification	Description	Désignation	Denominación
9	192	1	381 371 010		RAHMEN (R)		FRAME (R)	CADRE	MARKO
9	193	1	368 372 010		RAHMEN (L)		FRAME (L)	CADRE	MARKO
9	194	1	368 373 010		RAHMEN		REAR FRAME	CADRE	MARKO
9	195	1	368 374 010		RAHMEN		REAR FRAME	CADRE	MARKO
9	196	1	368 584 130		SCHAUMGUMMI	35X35X10	SPONGE	ÉPONGE	ESPONJA
9	197	2	368 584 140		SCHAUMGUMMI		SPONGE	ÉPONGE	ESPONJA
9	198	1	368 306 020		SOCKEL		BASE	SOCLE	BASE
9	199	1	368 583 100		SCHAUMGUMMI		SPONGE	ÉPONGE	ESPONJA
9	200	1	368 583 110		SCHAUMGUMMI	30X110X20	SPONGE	ÉPONGE	ESPONJA
9	201	2	368 583 200		SCHAUMGUMMI	40X240X1.5	SPONGE	ÉPONGE	ESPONJA
9	202	4	368 140 820		SCHRAUBE MIT SCHEIBE		BOLT & WASHER ASSY.	VIS AVEC RONDELLE	TORNILLO CON ARANDELA
9	203	1	368 301 010		HALTERUNG, BASIS KPL.		MOUNT, BASE CPL.	FIXATION, BASE CPL.	SOPORTE, BASE CPL.
9	204	1	368 301 010		HALTERUNG, BASIS KPL.		MOUNT, BASE CPL.	FIXATION, BASE CPL.	SOPORTE, BASE CPL.
9	205	4	368 380 600		MUTTER	M6	NUT	ECROU	TUERCA
9	206	1	368 418 360		ERDUNGSLEITUNG KPL.		EARTH WIRE CPL.	CONDUCTEUR DE MISE À LA TERRE CPL.	CABLE A TIERRA CPL.
9	207	4	383 006 002		BOLZEN	M6X1.0X14DX12L	BOLT	BOULON	BULÓN
9	208	5	368 380 010		MUTTER		NUT	ECROU	TUERCA
9	209	2	368 380 050		TÜLLE		GROMMET	PASSE-FIL	CAPERUCITA
9	210	1	368 376 010		ABDECKUNG KLP.		BACK PANEL CPL.	PANNEAU ARRIÈRE COMPLET	PANEL TRASERO COMPLETO
9	211	1	368 006 001		BOLZEN	M6X1.0X14DX8L	BOLT	BOULON	BULÓN
9	212	2	368 361 010		HALTERUNG KPL.		MOUNT CPL.	FIXATION CPL.	SOPORTE
9	213	2	368 361 010		HALTERUNG KPL.		MOUNT CPL.	FIXATION CPL.	SOPORTE
9	214	2	368 006 018		BOLZEN	M6X1.0X14DX18L	BOLT	BOULON	BULÓN
9	215	2	368 006 018		BOLZEN	M6X1.0X14DX18L	BOLT	BOULON	BULÓN
9	216	1	368 200 265		SCHILD		LABEL	PLAQUE	CALCOMANIA



GE-1100

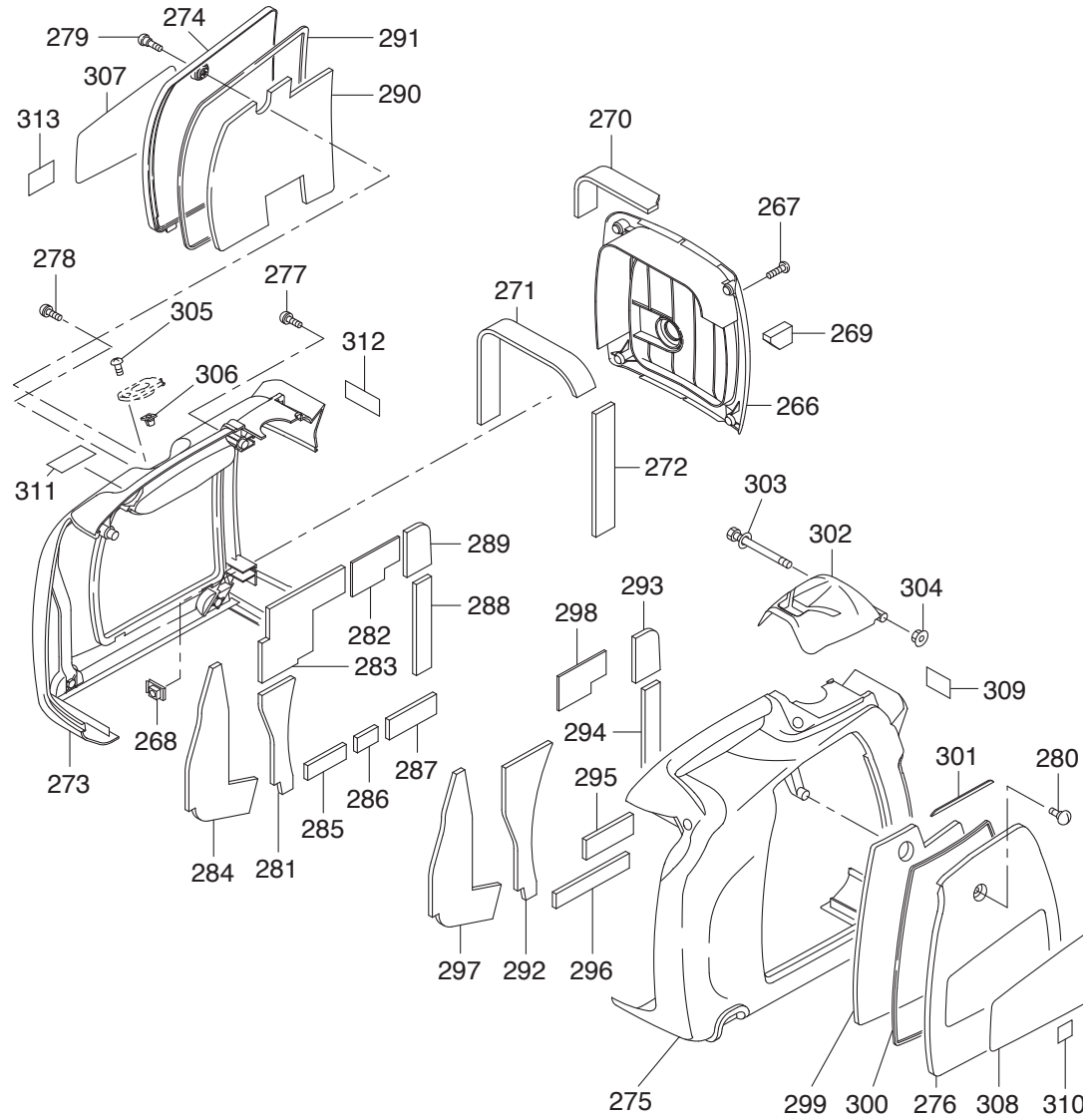

Seite / Page	Pos.	GE-1100	Teil-Nr. Part No. No. de pièce No. de pieza	Hinweise Notes Renseign. Nota	Bezeichnung	Spezifikation Specification	Description	Désignation	Denominación
10	217	4	368 005 010		SCHRAUBE		SCREW	VIS	TORNILLO
10	218	1	368 490 718		BEDIENFELD KPL.		CONTROL PANEL ASSY.	PANNEAU DE COMMANDE COMPLET	PANEL CONTROL COMPLETO
10	219	1	368 401 010		ABDECKUNG		FRONT PANEL	PANNEAU FRONTAL	PANEL FRONTAL
10	220	1	368 499 021		FOLIE		FILM	FILM	LAMINA
10	221	2	368 406 210		WECHSELSTROM-STECKDOSE	AC250V 16A	AC RECEPTACLE	PRISE COURANT ALTERNATIF	BASE DE ENCHUFE DE CA
10	222	8	368 360 312		SCHRAUBE MIT SCHEIBE KPL.		SCREW & WASHER ASSY.	VIS AVEC RONDELLE CPL.	TORNILLO CON ARANDELA CPL.
10	223	8	368 170 300		MÜTTER	M5	NUT	ECROU	TUERCA
10	224	1	368 407 070		HALTERUNG		BRACKET	FIXATION	SOPORTE
10	225	4	368 104 006		SCHRAUBE MIT SCHEIBE KPL.		SCREW & WASHER ASSY.	VIS AVEC RONDELLE CPL.	TORNILLO CON ARANDELA CPL.
10	226	1	368 110 133		ANZEIGE KPL.		INDICATOR CPL.	INDICATEUR CPL.	INDICADOR CPL.
10	227	2	368 003 002		SCHNEIDSCHRAUBE		TAPPING SCREW	VIS DE COUPE	TORNILLO DE ROSCA CORTANTE
10	228	1	368 418 110		MIKROSCHALTER		MICRO SWITCH	INTERRUPTEUR	INTERRUPTOR
10	229	1	368 420 100		SCHALTER		CONTROL DIAL	INTERRUPTEUR	INTERRUPTOR
10	230	1	368 420 710		KUGEL		BALL	BILLE	BOLA
10	231	1	368 420 740		FEDER		SPRING	RESSORT	MUELLE
10	232	1	368 420 200		HALTERUNG		BRACKET	FIXATION	SOPORTE
10	233	1	368 420 302		PLATTE		PLATE	PLAQUE	PLACA
10	234	1	368 420 400		PLATTE KPL.		PLATE CPL.	PLAQUE CPL.	PLACA CPL.
10	235	2	368 004 007		SCHNEIDSCHRAUBE		TAPPING SCREW	VIS DE COUPE	TORNILLO DE ROSCA CORTANTE
10	236	2	368 418 140		SCHNEIDSCHRAUBE	M3X16L	TAPPING SCREW	VIS DE COUPE	TORNILLO DE ROSCA CORTANTE
10	237	1	368 420 501		WELLE KPL.		WIRE CPL.	CABLE COMPLET	CABLE CPL.
10	238	1	368 420 800		HALTERUNG		BRACKET	FIXATION	SOPORTE
10	239	1	368 006 001		BOLZEN	M6X1.0X14DX8L	BOLT	BOULON	BULON
10	240	1	368 418 330		GLEICHSTR. UNTERBRECHERSCHALTER	RED 10A	CIRCUIT BREAKER (DC)	DISJONCTEUR	DISYUNTOR DE CIRCUITO
10	241	1	368 418 320		UNTERBRECHERSCHALTER		CIRCUIT BREAKER	DISJONCTEUR	DISYUNTOR DE CIRCUITO
10	242	2	368 103 001		SCHRAUBE MIT SCHEIBE KPL.		SCREW & WASHER ASSY.	VIS AVEC RONDELLE CPL.	TORNILLO CON ARANDELA CPL.
10	243	2	368 421 060		SCHRAUBE MIT SCHEIBE KPL.		SCREW & WASHER ASSY.	VIS AVEC RONDELLE CPL.	TORNILLO CON ARANDELA CPL.
10	244	2	368 418 170		KAPPE		CAP	CAPUCHON	CAPUCHA
10	245	1	368 421 070		SCHRAUBE		SCREW	VIS	TORNILLO
10	246	1	368 457 010		ANSCHUSSKLEMME	RED 20A	TERMINAL BOLT	BORNE	BORNE
10	247	1	368 457 000		ANSCHUSSKLEMME	BLACK 20A	TERMINAL BOLT	BORNE	BORNE
10	248	3	368 421 020		MÜTTER		NUT	ECROU	TUERCA
10	249	1	368 421 040		SCHRAUBE		SCREW	VIS	TORNILLO
10	250	2	368 499 030		SCHEIBE		WASHER	RONDELLE	ARANDELA
10	251	2	368 499 020		MÜTTER		NUT	ECROU	TUERCA
10	252	1	368 499 010		MÜTTER		NUT	ECROU	TUERCA
10	253	1	368 421 010		PLATTE		PLATE	PLAQUE	PLACA
10	254	1	368 421 000		PLATTE		PLATE	PLAQUE	PLACA
10	255	1	368 421 080		FEDERSCHEIBE		SPRING WASHER	RONDELLE A RESSORT	ARANDELA ELASTICO
10	256	1	368 418 390		KABELBAUM KPL.		PANEL HARNESS GER CPL.	FAISCEAU DE CABLES CPL.	MAZO DE CABLES CPL.
10	257	1	368 418 150		KABELBAUM		CONCENT HARNESS	FAISCEAU DE CABLES	MAZO DE CABLES
10	258	1	368 420 602		KABEL KPL.		CHOKE WIRE CPL.	CABLE CPL.	CABLE CPL.
10	259	1	368 300 002		BAND		WIRE BAND	BANDE	BANDA
10	260	1	368 584 110		ABDICHTUNG	4.5X650X2.5	GASKET	JOINT	JUNTA
10	261	1	368 930 600		SCHILD		LABEL	PLAQUE	CALCOMANIA
10	262	1	368 403 030		FOLIE		FILM	FILM	LAMINA
10	263	1	368 404 030		FOLIE		FILM	FILM	LAMINA
10	264	1	368 200 265		SCHILD		LABEL	PLAQUE	CALCOMANIA
10	265	1	368 200 449		SCHILD		LABEL	PLAQUE	CALCOMANIA



## GE-1100

DOLMAR



Seite / Page	Pos.	GE-1100	Teil-Nr. Part No. No. de pièce No. de pieza	Hinweise Notes Renseign. Nota	Bezeichnung	Spezifikation Specification	Description	Désignation	Denominación
11	266	1	368 502 010		ABDECKUNG		COVER	COUVERCLE	CUBIERTA
11	267	4	368 106 003		SCHRAUBE MIT SCHEIBE KPL.		SCREW & WASHER ASSY.	VIS AVEC RONDELLE CPL.	TORNILLO CON ARANDELA CPL.
11	268	4	368 502 050		MUTTER KPL.		NUT CPL.	ECROU CPL.	TUERCA CPL.
11	269	2	368 583 181		SCHAUMGUMMI		REAR COVER SPONGE	EPONGE	ESPONJA
11	270	1	368 583 191		SCHAUMGUMMI		REAR COVER SPONGE	EPONGE	ESPONJA
11	271	1	368 583 220		SCHAUMGUMMI		REAR COVER SPONGE	EPONGE	ESPONJA
11	272	1	368 583 240		SCHAUMGUMMI		REAR COVER SPONGE	EPONGE	ESPONJA
11	273	1	368 523 011		GEHAUSE LINKS		CASE LEFT	CARTER GAUCHE	CARTER IZQU
11	274	1	368 523 110		ABDECKUNG		COVER	COUVERCLE	CUBIERTA
11	275	1	368 524 011		GEHAUSE RECHTS		CASE RIGHT	CARTER DROITE	CARTER DERECHO
11	276	1	368 524 110		ABDECKUNG		COVER	COUVERCLE	CUBIERTA
11	277	2	368 360 625		SCHRAUBE MIT SCHEIBE KPL.		SCREW & WASHER ASSY.	VIS AVEC RONDELLE CPL.	TORNILLO CON ARANDELA CPL.
11	278	1	377 360 620		SCHRAUBE	M6X20	SCREW	VIS	TORNILLO
11	279	1	368 505 010		SCHRAUBE		BOLT	VIS	TORNILLO
11	280	1	368 505 010		SCHRAUBE		BOLT	VIS	TORNILLO
11	281	1	368 583 010		SCHAUMGUMMI		SPONGE	EPONGE	ESPONJA
11	282	1	368 583 070		SCHAUMGUMMI		SPONGE	EPONGE	ESPONJA
11	283	1	368 583 050		SCHAUMGUMMI		SPONGE	EPONGE	ESPONJA
11	284	1	368 583 040		SCHAUMGUMMI		SPONGE	EPONGE	ESPONJA
11	285	1	368 583 080		SCHAUMGUMMI	35X102X20	SPONGE	EPONGE	ESPONJA
11	286	1	368 583 090		SCHAUMGUMMI	35X55X20	SPONGE	EPONGE	ESPONJA
11	287	1	368 584 080		SCHAUMGUMMI	125X47X10	SPONGE	EPONGE	ESPONJA
11	288	1	368 584 090		SCHAUMGUMMI	217X40X10	SPONGE	EPONGE	ESPONJA
11	289	1	368 583 060		SCHAUMGUMMI		SPONGE	EPONGE	ESPONJA
11	290	1	368 583 020		SCHAUMGUMMI		SPONGE	EPONGE	ESPONJA
11	291	1	368 583 030		ABDICHTUNG	2.5X5X920	GASKET	JOINT	JUNTA
11	292	1	368 584 010		SCHAUMGUMMI		SPONGE	EPONGE	ESPONJA
11	293	1	368 584 060		SCHAUMGUMMI		SPONGE	EPONGE	ESPONJA
11	294	1	368 584 090		SCHAUMGUMMI	217X40X10	SPONGE	EPONGE	ESPONJA
11	295	1	368 584 080		SCHAUMGUMMI	125X47X10	SPONGE	EPONGE	ESPONJA
11	296	1	368 584 070		SCHAUMGUMMI	35X194X20	SPONGE	EPONGE	ESPONJA
11	297	1	368 584 040		SCHAUMGUMMI		SPONGE	EPONGE	ESPONJA
11	298	1	368 584 050		SCHAUMGUMMI		SPONGE	EPONGE	ESPONJA
11	299	1	368 584 020		SCHAUMGUMMI		SPONGE	EPONGE	ESPONJA
11	300	1	368 584 030		ABDICHTUNG	2.5X5X860	GASKET	JOINT	JUNTA
11	301	1	368 584 100		ABDICHTUNG		GASKET	JOINT	JUNTA
11	302	1	368 552 011		ABDECKUNG		COVER	COUVERCLE	CUBIERTA
11	303	1	368 104 009		SCHRAUBE MIT SCHEIBE KPL.		SCREW & WASHER ASSY.	VIS AVEC RONDELLE CPL.	TORNILLO CON ARANDELA CPL.
11	304	1	368 004 000		MUTTER		NUT	ECROU	TUERCA
11	305	1	368 004 009		SCHNEIDSCHRAUBE	4X10	TAPPING SCREW	VIS DE COUPE	TORNILLO DE ROSCA CORTANTE
11	306	1	368 530 020		TULLE		SCREW GROMMET	OEILLET VIS	ARMELLA ROSCADA
11	307	1	368 900 502		SCHILD		LABEL	PLAQUE	CALCOMANIA
11	308	1	368 910 503		SCHILD		LABEL	PLAQUE	CALCOMANIA
11	309	1	368 920 603		SCHILD		LABEL	PLAQUE	CALCOMANIA
11	310	1	368 200 452		SCHILD		LABEL	PLAQUE	CALCOMANIA
11	311	1	368 200 451		SCHILD		LABEL	PLAQUE	CALCOMANIA
11	312	1	368 200 450		SCHILD		LABEL	PLAQUE	CALCOMANIA
11	313	1	368 200 519		SCHILD		LABEL	PLAQUE	CALCOMANIA

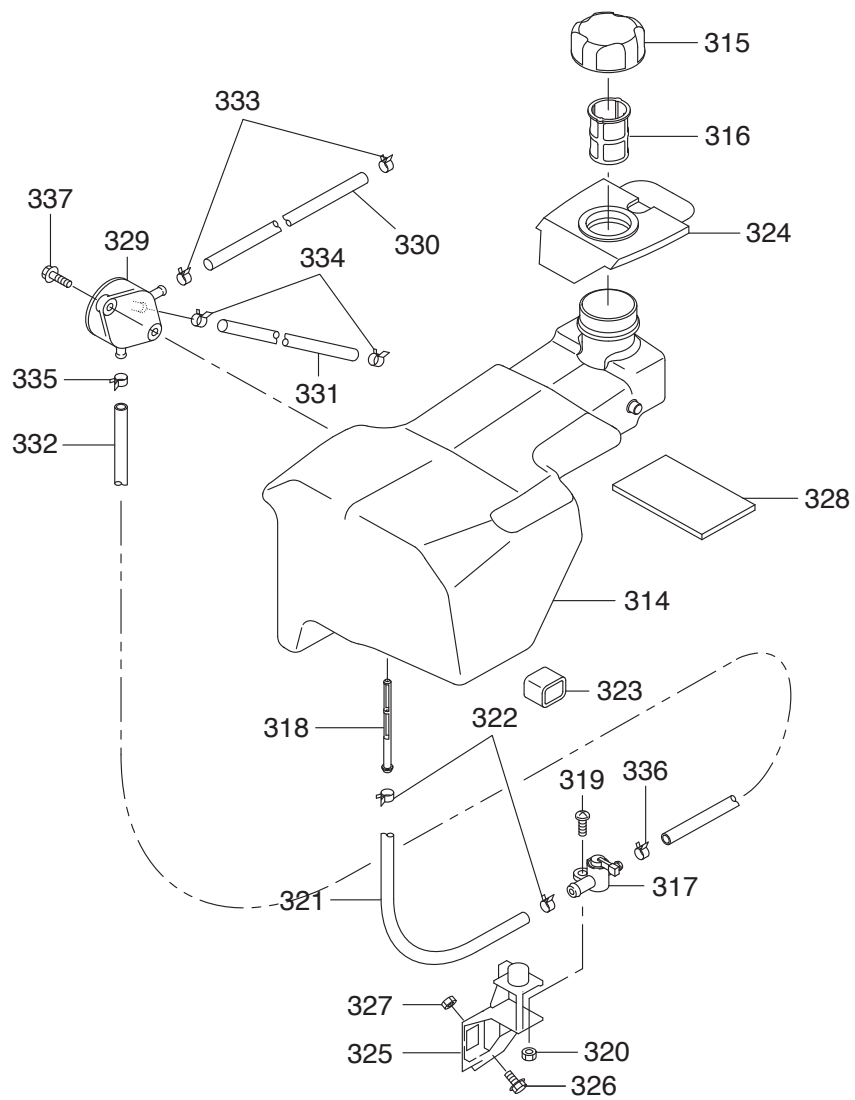



## GE-1100



Seite / Page	Pos.	GE-1100	Teil-Nr. Part No. No. de pièce No. de pieza	Hinweise Notes Renseign. Nota	Bezeichnung	Spezifikation Specification	Description	Désignation	Denominación
12	314	1	368 611 011		KRAFTSTOFFTANK		FUEL TANK	RESERVOIR D'ESSENCE	DEPÓSITO DE COMBUSTIBLE
12	315	1	368 650 100		TANKVERSCHLUSS KPL.		FUEL TANK CAP ASSY.	BOUCHON RÉSERVOIR CPL.	CIERRE DEPÓSITO CPL.
12	316	1	368 612 011		BENZINFILTER KPL.		GASOLIN FILTER CPL.	FILTRE D'ESSENCE CPL.	FILTRO DE GASOLINA CPL.
12	317	1	368 630 011		KRAFTSTOFFHAHN KPL.		FUEL COCK ASSY.	ROBINET D'ESSENCE CPL.	LLAVE DE COMBUSTIBLE CPL.
12	318	1	368 614 010		KRAFTSTOFFFILTER		FUEL STRAINER	TAMIS	TAMIZ
12	319	1	381 360 512		SCHRAUBE KPL.	M5X12	SCREW ASSY.	VIS CPL.	TORNILLO CPL.
12	320	1	367 180 500		MUTTER	M5	NUT	ECROU	TUERCA
12	321	1	368 622 500		SCHLAUCH		RUBBER PIPE	TUYAU SOUPLE	TUBO FLEXIBLE
12	322	2	368 113 001		SCHLAUCHKLEMME	13.2DX10BX0.8T	HOSE CLAMP	COLLIER	ABRAZADERA
12	323	2	368 641 010		HALTERUNG		MOUNT	FIXATION	SOPORTE
12	324	1	368 640 011		GUMMISTUTZEN		NECK RUBBER	MANCHON DE CAOUTCHOUC	TUBO DE GOMA
12	325	1	368 630 020		HALTERUNG		MOUNT	FIXATION	SOPORTE
12	326	1	368 006 003		BOLZEN	M6X1.0X14DX14L	BOLT	BOULON	BULÓN
12	327	1	377 170 600		MUTTER	M6	NUT	ECROU	TUERCA
12	328	1	368 584 121		SCHAUMGUMMI	80X45X5	SPONGE	ÉPONGE	ESPONJA
12	329	1	368 622 010		KRAFTSTOFFPUMPE KPL.		FUEL PUMP CPL.	POMPE D'ESSENCE CPL.	BOMBA DE COMBUSTIBLE CPL.
12	330	1	368 196 000		SCHLAUCH	1 M	RUBBER PIPE	TUYAU SOUPLE	TUBO FLEXIBLE
12	331	1	368 196 000		SCHLAUCH	1 M	RUBBER PIPE	TUYAU SOUPLE	TUBO FLEXIBLE
12	332	1	368 196 000		SCHLAUCH	1 M	RUBBER PIPE	TUYAU SOUPLE	TUBO FLEXIBLE
12	333	2	368 111 002		SCHLAUCHKLEMME	11.5DX8BX0.7T	HOSE CLAMP	COLLIER	ABRAZADERA
12	334	2	368 111 002		SCHLAUCHKLEMME	11.5DX8BX0.7T	HOSE CLAMP	COLLIER	ABRAZADERA
12	335	1	368 111 002		SCHLAUCHKLEMME	11.5DX8BX0.7T	HOSE CLAMP	COLLIER	ABRAZADERA
12	336	1	368 111 002		SCHLAUCHKLEMME	11.5DX8BX0.7T	HOSE CLAMP	COLLIER	ABRAZADERA
12	337	2	368 006 002		SCHNEIDSCHRAUBE		TAPPING SCREW	VIS DE COUPE	TORNILLO DE ROSCA CORTANTE

GE-1100

13

Werkzeug  
Tool set  
Outils  
Herramientas

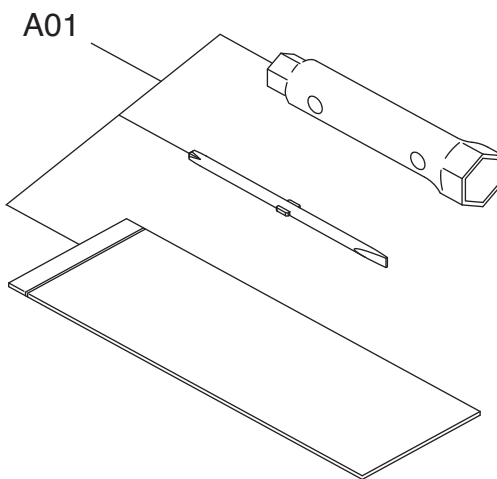

**GE-1100**



Seite / Page	Pos.	GE-1100	Teil-Nr. Part No. No. de pièce No. de pieza	Hinweise Notes Renseign. Nota	Bezeichnung	Spezifikation Specification	Description	Désignation	Denominación
13	A01	1	368 990 010		WERKZEUGSATZ		ACCESSORY TOOL KIT	OUTILS CPL	HERRAMIENTAS CPL.

<b>1</b>	Kurbelgehäuse, Zylinder	Crankcase, cylinder	Carter-vilebrequin, cylindre	Carter cigüeñal, cilindro
<b>2</b>	Kurbelwelle, Kolben	Crankshaft, piston	Vilebrequin, piston	Cigüeñal, pistón
<b>3</b>	Ventile, Luftfilter, Schalldämpfer	Valves, air cleaner, muffler	Soupapes, filtre à air, pot d'échappement	Válvulas, filtro de aire, silenciador
<b>4</b>	Reglerhebel	Governor lever	Levier régulateur	Palanca regulador
<b>5</b>	Anwerfvorrichtung, Ventilatorgehäuse	Starter, blower housing	Dispositivo de démarrage, carter de ventilateur	Dispositivo de arranque, carcasa del ventilador
<b>6</b>	Vergaser	Carburetor	Carbureteur	Carburador
<b>7</b>	Zündung	Ignition	Bobine d'allumage	Bobina encendido
<b>8</b>	Rotor, Stator	Rotor, stator	Rotor, stator	Rotor, estador
<b>9</b>	Rahmen	Frame	Cadre	Marko
<b>10</b>	Frontblende	Front panel	Panneau frontal	Panel frontal
<b>11</b>	Gehäuse	Housing	Carter	Caja
<b>12</b>	Kraftstofftank	Fuel tank	Reservoir d'essence	Depósito de combustible
<b>13</b>	Werkzeug	Tool set	Outils	Herramientas

	<b>Zeichenerklärung</b>	<b>Key to symbols</b>	<b>Légende</b>	<b>Explicación de símbolos</b>
<b>⇒ 1999999</b> <b>2000000 ⇒</b> <b>2003.04 ⇒</b> <b>TI 2003/07</b> <b>Acc.</b> <b>=</b> <b>{</b> <b>m</b> <b>Corr.</b>	Produktion bis Serien-Nr. Neues Teil ab Serien-Nr. Neues Teil ab Jahr / Monat Siehe Technische Information Jahr / Nr. Zubehör (nicht im Lieferumfang) Keine Serienausführung, jedoch verwendbar Beinhaltet Positions-Nr. Meterware Druckfehlerberichtigung	Production to serial number New part from serial number New part from Year / Month See Technical Information Year / No. Accessories (not included in the delivery inventory) No standard execution, may be used Contains item number Sold by the meter Error correction	Production jusqu'à n° de série Nouveau pièce à partir du n° de série Nouveau pièce à partir de année / mois Voir information technique année / n° Accessoires (non compris dans la livraison) Aucune exécut. en série, cependant utilisable contient n° de numéro Au mètre Rectification d'erreurs	Producción hasta N° de serie Pieza nueva a partir de N° de serie Pieza nueva a partir de año / mes Véase inform. técnico año / N° Accesorios (no incluido en la extensión del suministro) No es de serie, pero sirve Contiene pos N° Por metro Fe de erratas
	Änderungen vorbehalten	Specifications subject to change without notice	Changements sans préavis	Mejoras constructivas sin previo aviso