

Ersatzteilliste
Spare Parts List
Liste de pièces détachées
Lista de piezas de repuesto

2006-09



EM-3310 2006 →
EM-3713 2006 →
EM-4316 S 2006 →
EM-4816 2006 →



PM-43 2006 →
PM-48 2006 →
PM-48 S 2006 →
PM-480 S 2006 →
PM-4850 2006 →
PM-4850 S 2006 →
PM-5150 S 2006 →

DOLMAR



A member of the *Makita* Group

995 700 128 (DE, GB, FR, ES)

1

EM-3310

DOLMAR
■■■■■■■■■■

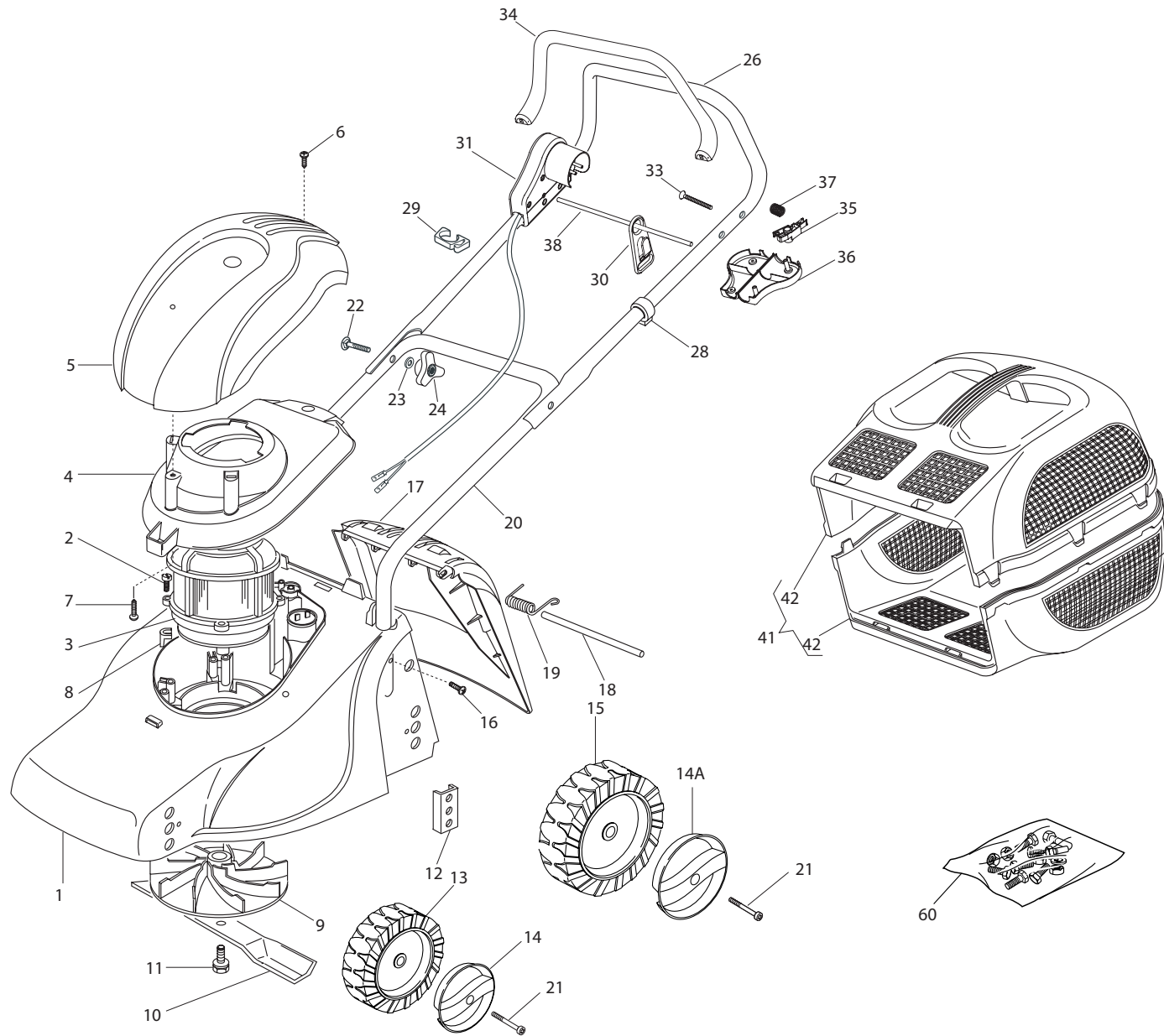

Seite / Page	Pos.	EM-3310	EM-3713	EM-4316 S	EM-4816	PM-43	PM-48	PM-48 S	PM-480 S	PM-4850	PM-4850 S	PM-5150 S	Teil-Nr. Part No. No. de pièce No. de pieza	Bezeichnung	Spezifikation Specification	Description	Désignation	Denominación
1	1	1											664 002 366	GEHAUSE ROT		DECK RED	CHASSIS ROUGE	CAJA ROJA
1	2	4											664 735 410	SCHRAUBE		SCREW	VIS	TORNILLO
1	3	1											664 563 650	MOTOR	1100 W	MOTOR	MOTEUR	MOTOR
1	4	1											664 055 050	HALTER, HAUBE		SUPPORT, COVER	SUPPORT CAPOT	SOPORTE, CUBIERTA
1	5	1											664 055 049	HAUBE		COVER	CAPOT	CUBIERTA
1	6	1											664 728 680	SCHRAUBE		SCREW	VIS	TORNILLO
1	7	1											664 728 450	SCHRAUBE		SCREW	VIS	TORNILLO
1	8	4											664 167 700	DISTANZRING		SPACER	ENTRETOISE	DISTANCIADOR
1	9	1											664 465 602	MESSERHALTER		HUB	MOYEU	SOPORTE DE LA CUCHILLA
1	10	1											664 004 115	MESSER	33 CM	BLADE	LAME	CUCHILLA ESTÁNDAR
1	11	1											664 004 352	MESSERSCHRAUBE		SCREW	VIS	TORNILLO
1	12	4											664 785 087	HÖHENVERSTELLUNG		SUPPORT, WHEELS	SUPPORT ROUE	SOPORTE, RUEDAS
1	13	2											664 686 083	RAD	Ø 130	WHEEL	ROUE	RUEDA
1	14	2											664 110 434	RADKAPPE ROT		HUB CAP RED	COUVRE-MOYEU ROUGE	TAPACUBOS ROJO
1	14A	2											664 110 446	RADKAPPE ROT		HUB CAP RED	COUVRE-MOYEU ROUGE	TAPACUBOS ROJO
1	15	2											664 686 085	RAD	Ø 160	WHEEL	ROUE	RUEDA
1	16	2											664 728 450	SCHRAUBE		SCREW	VIS	TORNILLO
1	17	1											664 600 055	PRALLBLECH		STONE-GUARD	PARE-PIERRES	CUBIERTA PROTECTORA
1	18	1											664 512 530	BOLZEN		PIN	PIVOT	PIVOTE
1	19	1											664 450 250	FEDER		SPRING	RESSORT	RESORTE
1	20	1											664 006 608	HOLM, UNTERTEIL		HANDLE, LOWER PART	MANCHERON, PARTIE INFERIEURE	MANILLAR, PARTE INFERIOR
1	21	1											664 524 337	BOLZEN		PIN	PIVOT	PIVOTE
1	22	2											664 815 245	SCHRAUBE		SCREW	VIS	TORNILLO
1	23	2											664 523 040	SCHEIBE		WASHER	RONDELLE	ARANDELA
1	24	2											664 399 903	GRIFF		KNOB	POIGNÉE	MANETA
1	26	1											664 006 647	HOLM, OBERTEIL		HANDLE, UPPER PART	MANCHERON, PARTIE SUPERIEURE	MANILLAR, PARTE SUPERIOR
1	28	1											664 192 151	KABELBEFESTIGUNG		FAIRLEAD	FIXATION CABLE	SUJETACABLE
1	29	1											664 192 010	BOWDENZUGHALTER		ANCHOR CLAMP	COLLIER ANCRAGE	SOPORTE CABLE BOWDEN
1	30	1											664 195 101	KABELBEFESTIGUNG		FAIRLEAD	FIXATION CABLE	SUJETACABLE
1	31	1											664 600 503	TOTMANN-SCHALTER		DEAD HAND SWITCH	INT. MAIN MORTE	INTERRUPTOR DE HOMBRE MUERTO
1	33	4											664 728 685	SCHRAUBE		SCREW	VIS	TORNILLO
1	34	1											664 322 880	HEBEL, MOTORBREMSE		LEVER, MOTOR BRAKE	LEVIER FREIN MOTEUR	PALANCA, FRENO MOTOR
1	35	1											664 230 350	GELENKPUNKT		FULCRUM PIN	POINT D'APPUI	PUNTO DE ARTICULACIÓN
1	36	1											664 785 144	HALTER		SUPPORT	SUPPORT	SOPORTE
1	37	1											664 450 115	FEDER		SPRING	RESSORT	RESORTE
1	38	1											664 010 250	KABELHALTER		FAIRLEAD BEARING	SUPPORT SERRECABLE	SOPORTE SUJETACABLE
1	41	1											664 350 000	KORB, KOMPLETT		GRASSCATCHER, COMPLETE	SAC, COMPLETE	CESTO, COMPLETO
1	42	2											664 486 048	KORB, OBER/UNTERTEIL		GRASS-BOX, UPPER/LOWER PART	SAC, PARTIE INFERIEURE/SUPERIEURE	CESTO, PARTE SUPERIOR/INFERIOR
1	60	1											664 008 668	SATZ, SCHRAUBEN		OUTFIT, SCREWS	DOTATION VISSERIE	JUEGO DE TORNILLOS

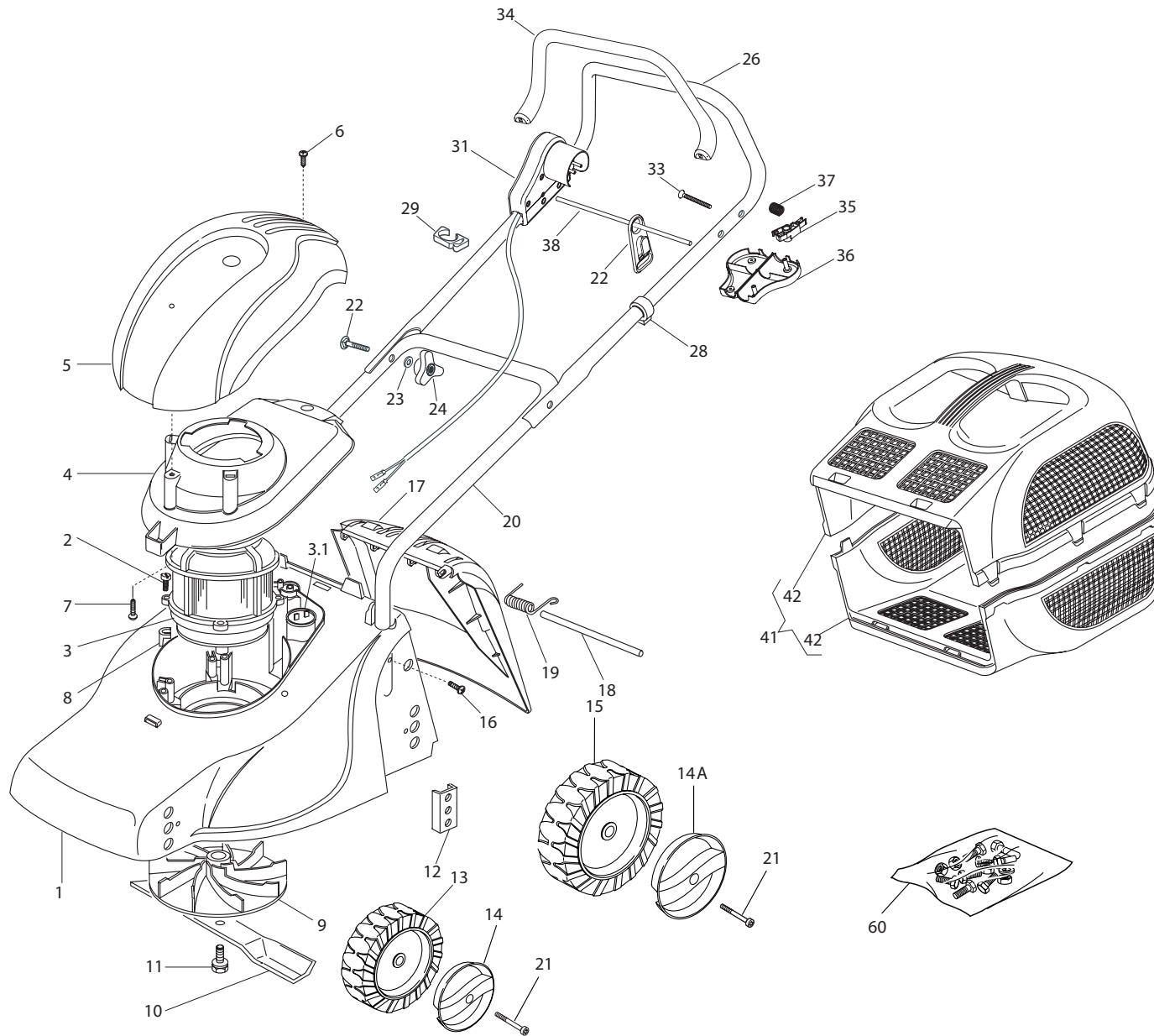

Seite / Page	Pos.	EM-3310	EM-3713	EM-4316 S	EM-4816	PM-43	PM-48	PM-48 S	PM-480 S	PM-4850	PM-4850 S	PM-5150 S	Teil-Nr. Part No. No. de pièce No. de pieza	Bezeichnung	Spezifikation Specification	Description	Désignation	Denominación
2	1		1										664 002 367	GEHAUSE ROT		DECK RED	CHASSIS ROUGE	CAJA ROJA
2	2		4										664 735 410	SCHRAUBE		SCREW	VIS	TORNILLO
2	3		1										664 563 651	MOTOR	1300 W	MOTOR	MOTEUR	MOTOR
2	3,1		1										664 222 037	KONDENSATOR	16 µF	CONDENSER	CONDENSEUR	CONDENSADOR
2	4		1										664 055 050	HALTER, HAUBE		SUPPORT, COVER	SUPPORT CAPOT	SOPORTE, CUBIERTA
2	5		1										664 055 049	HAUBE		COVER	CAPOT	CUBIERTA
2	6		1										664 728 680	SCHRAUBE		SCREW	VIS	TORNILLO
2	7		1										664 728 450	SCHRAUBE		SCREW	VIS	TORNILLO
2	8		4										664 167 700	DISTANZRING		SPACER	ENTRETOISE	DISTANCIADOR
2	9		1										664 465 602	MESSERHALTER		HUB	MOYEU	SOPORTE DE LA CUCHILLA
2	10		1										664 004 117	MESSER	37CM	BLADE	LAME	CUCHILLA ESTÁNDAR
2	11		1										664 004 352	MESSERSCHRAUBE		SCREW	VIS	TORNILLO
2	12		4										664 785 087	HÖHENVERSTELLUNG		SUPPORT, WHEELS	SUPPORT ROUE	SOPORTE, RUEDAS
2	13		2										664 686 083	RAD VORNE	D=130	WHEEL	ROUE	RUEDA
2	14		2										664 110 434	RADKAPPE ROT		HUB CAP RED	COUVRE-MOYEU ROUGE	TAPACUBOS ROJO
2	14A		2										664 110 446	RADKAPPE ROT		HUB CAP RED	COUVRE-MOYEU ROUGE	TAPACUBOS ROJO
2	15		2										664 686 085	RAD HINTEN	D=160	WHEEL	ROUE	RUEDA
2	16		2										664 728 450	SCHRAUBE		SCREW	VIS	TORNILLO
2	17		1										664 600 056	PRALLBLECH		STONE-GUARD	PARE-PIERRES	CUBIERTA PROTECTORA
2	18		1										664 512 530	BOLZEN		PIN	PIVOT	PIVOTE
2	19		1										664 450 250	FEDER		SPRING	RESSORT	RESORTE
2	20		1										664 006 608	HOLM, UNTERTEIL		HANDLE, LOWER PART	MANCHERON, PARTIE INFERIEURE	MANILLAR, PARTE INFERIOR
2	21		1										664 524 337	BOLZEN		PIN	PIVOT	PIVOTE
2	22		2										664 815 245	SCHRAUBE		SCREW	VIS	TORNILLO
2	23		2										664 523 040	SCHEIBE		WASHER	RONDELLE	ARANDELA
2	24		2										664 399 903	GRIFF		KNOB	POIGNÉE	MANETA
2	26		1										664 006 647	HOLM, OBERTEIL		HANDLE, UPPER PART	MANCHERON, PARTIE SUPERIEURE	MANILLAR, PARTE SUPERIOR
2	28		1										664 192 151	KABELBEFESTIGUNG		FAIRLEAD	FIXATION CABLE	SUJETACABLE
2	29		1										664 192 010	BOWDENZUGHALTER		ANCHOR CLAMP	COLLIER ANCRAGE	SOPORTE CABLE BOWDEN
2	30		1										664 195 101	KABELBEFESTIGUNG		FAIRLEAD	FIXATION CABLE	SUJETACABLE
2	31		1										664 600 503	TOTMANN-SCHALTER		DEAD HAND SWITCH	INT. MAIN MORTE	INTERRUPTOR DE HOMBRE MUERTO
2	32		1										664 034 601	SCHUTZ		PROTECTION	PROTECTION	PROTECCIÓN
2	33		4										664 728 685	SCHRAUBE		SCREW	VIS	TORNILLO
2	34		1										664 322 880	HEBEL MOTORBREMSE		LEVER, MOTOR BRAKE	LEVIER FREIN MOTEUR	PALANCA, FRENO MOTOR
2	35		1										664 230 350	GELENKPUNKT		FULCRUM PIN	POINT D'APPUI	PUNTO DE ARTICULACIÓN
2	36		1										664 785 144	HALTER		SUPPORT	SUPPORT	SOPORTE
2	37		1										664 450 115	FEDER		SPRING	RESSORT	RESORTE
2	38		1										664 010 250	KABELHALTER		FAIRLEAD BEARING	SUPPORT SERRECABLE	SOPORTE SUJETACABLE
2	41		1										664 390 000	KORB, KOMPLETT		GRASSCATCHER, COMPLETE	SAC, COMPLETE	CESTO, COMPLETO
2	42		2										664 486 049	KORB, OBER/UNTERTEIL		GRASS-BOX, UPPER/LOWER PART	SAC	CESTO
2	60		1										664 008 668	SATZ, SCHRAUBEN		OUTFIT, SCREWS	DOTATION VISSERIE	JUEGO DE TORNILLOS

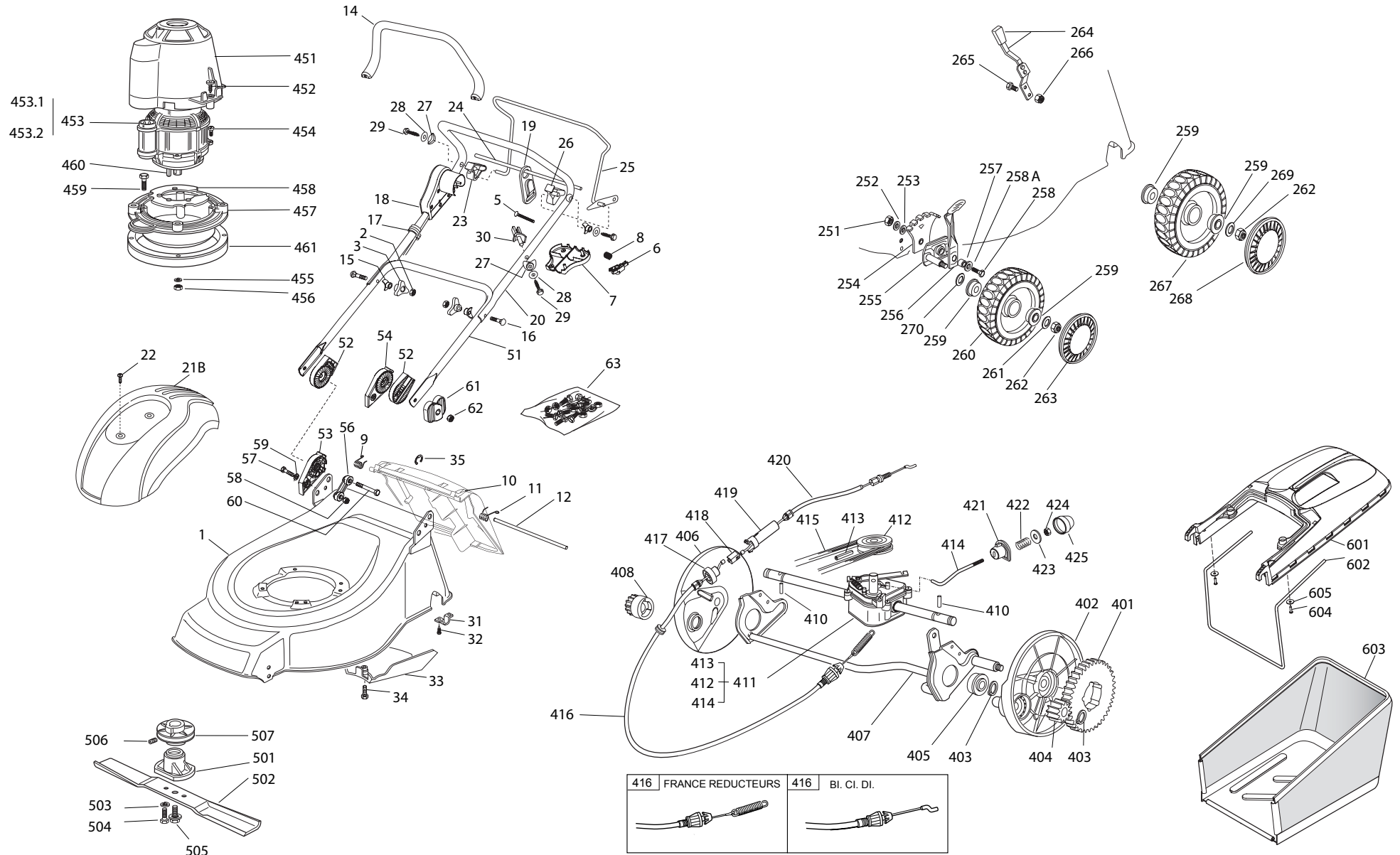

Seite / Page	Pos.	EM-3310	EM-3713	EM-4316 S	EM-4816	PM-43	PM-48	PM-48 S	PM-480 S	PM-4850	PM-4850 S	PM-5150 S	Teil-Nr. Part No. No. de pièce No. de pieza	Bezeichnung	Spezifikation Specification	Description	Désignation	Denominación
3	1			1									664 002 363	GEHAUSE ROT		DECK RED	CHASSIS ROUGE	CAJA ROJA
3	2			2									664 293 200	6KT-MUTTER	M8	NUT	ECROU	TUERCA
3	3			2									664 399 900	GRIFF		KNOB	POIGNÉE	MANETA
3	5			4									664 728 685	SCHRAUBE		SCREW	VIS	TORNILLO
3	6			1									664 230 350	GELENKPUNKT		FULCRUM PIN	POINT D'APPUI	PUNTO DE ARTICULACIÓN
3	7			1									664 785 144	HALTER		SUPPORT	SUPPORT	SOPORTE
3	8			1									664 450 115	FEDER		SPRING	RESSORT	RESORTE
3	9			1									664 450 410	FEDER RECHTS		RIGHT SPRING	RESSORT D	RESORTE DER.
3	10			1									664 600 063	PRALLBLECH		STONE-GUARD	PARE-PIERRES	CUBIERTA PROTECTORA
3	11			1									664 450 420	FEDER LINKS		L SPRING	RESSORT G	RESORTE IZQ.
3	12			1									664 517 906	BOLZEN		PIN	PIVOT	PIVOTE
3	14			1									664 322 881	HEBEL, MOTORBREMSE		LEVER, MOTOR BRAKE	LEVIER FREIN MOTEUR	PALANCA, FRENO MOTOR
3	15			2									664 680 006	SCHEIBE		WASHER	RONDELLE	ARANDELA
3	16			2									664 819 201	SCHRAUBE		SCREW	VIS	TORNILLO
3	17			3									664 192 000	BOWDENZUGHALTER		ANCHOR CLAMP	COLLIER ANCRAGE	GRAPA DE SUJECIÓN
3	18			1									664 600 503	TOTMANN-SCHALTER		DEAD HAND SWITCH	INT. MAIN MORTE	INTERRUPTOR DE HOMBRE MUERTO
3	19			1									664 195 101	KABELBEFESTIGUNG		FAIRLEAD	FIXATION CABLE	SUJETACABLE
3	20			1									664 006 603	HOLM, OBERTEIL		HANDLE, UPPER PART	MANCHERON, PARTIE SUPERIEURE	MANILLAR, PARTE SUPERIOR
3	21B			1									664 055 065	HAUBE		COVER	CAPOT	CUBIERTA
3	22			2									664 728 680	SCHRAUBE		SCREW	VIS	TORNILLO
3	23			1									664 806 518	HALTER, RECHTS		SUPPORT, R	SUPPORT D	SOPORTE DER.
3	24			1									664 010 251	KABELHALTER		FAIRLEAD BEARING	SUPPORT SERRECABLE	SOPORTE SUJETACABLE
3	25			1									664 001 245	HEBEL, ANTRIEB		LEVER, DRIVING	LEVIER TRACTION	PALANCA, CONDUCCIÓN
3	26			1									664 806 519	HALTER, LINKS		SUPPORT, L	SUPPORT G	SOPORTE, IZQ.
3	27			3									664 680 006	SCHEIBE		WASHER	RONDELLE	ARANDELA
3	28			3									664 523 040	SCHEIBE		WASHER	RONDELLE	ARANDELA
3	29			3									664 735 103	SCHRAUBE		SCREW	VIS	TORNILLO
3	30			1									664 806 520	HALTER, REGLER		SUPPORT, ADJUSTER	SUPPORT ECROU REG.	SOPORTE, AJUSTE
3	31			2									664 545 152	LAGERSCHALE		PLATE	PLAQUETTE	COJINETE
3	32			4									664 731 350	SCHRAUBE		SCREW	VIS	TORNILLO
3	33			1									664 060 191	SCHUTZ, RIEMEN		PROTECTION, BELT	PROTECTION	PROTECCIÓN, CORREA
3	34			1									664 727 791	SCHRAUBE		SCREW	VIS	TORNILLO
3	35			1									664 000 930	SPRENGRING		SNAP RING	ANNEAU RESSORT	ANILLO DE SUJECIÓN
3	51			1									664 006 532	HOLM, UNTERTEIL		HANDLE, LOWER PART	MANCHERON, PARTIE INFERIEURE	MANILLAR, PARTE INFERIOR
3	52			2									664 785 081	HALTER, AUßEN		SUPPORT, EXTERNAL	SUPPORT EXTERNE	SOPORTE, EXTERIOR
3	53			1									664 785 082	HALTER, INNEN R		SUPPORT, R INTERNAL	SUPPORT INTERNE D	SOPORTE INTERIOR, DER.
3	54			1									664 785 083	HALTER, INNEN L		SUPPORT, L INTERNAL	SUPPORT INTERNE G	SOPORTE INTERIOR, IZQ.
3	56			2									664 551 575	PLATTE, INNEN		PLATE, INSIDE	PLAQUETTE INTERNE	PLANCHA, INTERIOR
3	57			2									664 793 701	SCHRAUBE		SCREW	VIS	TORNILLO
3	58			2									664 155 000	MUTTER		NUT	ECROU	TUERCA
3	59			2									664 521 350	SCHEIBE		WASHER	RONDELLE	ARANDELA
3	60			2									664 691 810	SCHRAUBE		SCREW	VIS	TORNILLO
3	61			2									664 399 803	GRIFF		KNOB	POIGNÉE	MANETA
3	62			2									664 293 202	MUTTER		NUT	ECROU	TUERCA
3	63			1									664 008 622	SATZ, SCHRAUBEN		OUTFIT, SCREWS	DOTATION VISSERIE	JUEGO DE TORNILLOS
3	251			2									664 293 200	6KT-MUTTER	M8	NUT	ECROU	TUERCA
3	252			2									664 583 500	FEDERRING		GROWER	GROWER	ARANDELA DE PRESIÓN
3	253			2									664 523 070	SCHEIBE		WASHER	RONDELLE	ARANDELA
3	254			2									664 735 547	SEKTOR, HÖHENVERSTELLUNG		SECTOR, HEIGHT ADJUSTMENT	SECTEUR REGLAGE HAUTEUR	SECTOR, AJUSTE ALTURA
3	255			2									664 005 082	RADHALTER		SUPPORT, WHEEL	SUPPORT ROUE	SOPORTE, RUEDA

Seite / Page	Pos.	EM-3310	EM-3713	EM-4316 S	EM-4816	PM-43	PM-48	PM-48 S	PM-480 S	PM-4850	PM-4850 S	PM-5150 S	Teil-Nr. Part No. No. de pièce No. de pieza	Bezeichnung	Spezifikation Specification	Description	Désignation	Denominación
3	256			2									664 003 285	HEBEL, HOHENVERSTELLUNG		LEVER, HEIGHT ADJUSTMENT	LEVIER, REGLAGE HAUTEUR	PALANCA, AJUSTE ALTURA
3	257			2									664 171 001	DISTANZRING		SPACER	ENTRETOISE	DISTANCIADOR
3	258			2									664 793 701	SCHRAUBE		SCREW	VIS	TORNILLO
3	258A			2									664 521 350	SCHEIBE		WASHER	RONDELLE	ARANDELA
3	259			8									664 122 200	KUGELLAGER		BEARING	COUSSINET	RODAMIENTO
3	260			2									664 007 336	RAD MIT STOLLENPROFIL	Ø 170	WHEEL, KNOBBLY	ROUE SCULPTEE	RUEDA CON PERFIL
3	261			2									664 521 350	SCHEIBE		WASHER	RONDELLE	ARANDELA
3	262			4									664 155 000	MUTTER		NUT	ECROU	TUERCA
3	263			2									664 110 304	RADKAPPE ROT		HUB CAP RED	COUVRE-MOYEU ROUGE	TAPACUBOS ROJO
3	264			1									664 003 279	RASTHEBEL		LEVER, HEIGHT ADJUSTMENT	LEVIER, REGLAGE HAUTEUR	PALANCA, AJUSTE ALTURA
3	265			2									664 789 000	SCHRAUBE		SCREW	VIS	TORNILLO
3	266			2									664 154 330	MUTTER		NUT	ECROU	TUERCA
3	267			2									664 007 337	RAD MIT STOLLENPROFIL	Ø 210	WHEEL, KNOBBLY	ROUE SCULPTEE	RUEDA CON PERFIL
3	268			2									664 110 305	RADKAPPE ROT		HUB CAP RED	COUVRE-MOYEU ROUGE	TAPACUBOS ROJO
3	269			2									664 369 500	FEDERSCHEIBE		ELASTIC WASHER	DISQUE ELASTIQUE	ARANDELA ELÁSTICA
3	270			2									664 530 150	FEDERSCHEIBE		ELASTIC WASHER	RONDELLE ELASTIQUE	ARANDELA ELÁSTICA
3	401			2									664 120 105	ZAHNRAD		RING GEAR	COURONNE	CORONA DENTADA
3	402			1									664 600 093	SCHUTZ, LINKS RÄDER		PROTECTION, L WHEEL	PROTECTION ROUE G	PROTECCIÓN, RUEDA IZQ.
3	403			4									664 608 600	SICHERUNGSRING		SEEGER	SEEGER	ANILLO DE SEGURIDAD
3	404			1									664 570 120	RITZEL LINKS		PINION L	PIGNON G	PINÓN, IZQ.
3	405			2									664 216 035	LAGER		BEARING	COUSSINET	RODAMIENTO
3	406			1									664 600 092	SCHUTZ, RECHTS, RÄDER		PROTECTION, R WHEEL	PROTECTION ROUE D	PROTECCIÓN, RUEDA DER.
3	407			1									664 000 147	ACHSE, HINTERRAD		AXLE, REAR WHEELS	AXE ROUES ARRIERE	EJE, RUEDAS TRASERAS
3	408			1									664 570 110	RITZEL RECHTS		PINION RIGHT	PIGNON D	PINÓN, DER.
3	410			2									664 753 000	STIFT		PIN	GOUPILLE	PASADOR
3	411			1									664 003 081	ANTRIEB (GRAU)	(Bl. Ci. Di.)	GEAR BOX (GREY)	GROUPE TRACTION	UNIDAD DE TRACCIÓN (GRIS)
3	411			1									664 003 076	ANTRIEB	(FRANCE REDUCTEURS)	GEAR BOX	GROUPE TRACTION	UNIDAD DE TRACCIÓN
3	412			1									664 601 904	RIEMENSCHLEIBE		PULLEY	POULIE	POLEA
3	413			1									664 645 705	STIFT		PIN	GOUPILLE	PASADOR
3	414			1									664 033 280	VERSTELLHEBEL	(Bl. Ci. Di.)	ADJUSTMENT ROD	TIGE REGLAGE	VÁSTAGO DE AJUSTE
3	414			1									664 033 283	VERSTELLHEBEL	(FRANCE REDUCTEURS)	ADJUSTMENT ROD	TIGE REGLAGE	VÁSTAGO DE AJUSTE
3	415			1									664 063 710	RIEMEN	Z=25	BELT	COURROIE	CORREA
3	416			1									664 000 676	KABEL ANTRIEB OBER	(Bl. Ci. Di.)	CABLE, REAR DRIVE LOWER	CABLE TRACTION SUPERIEURE	CABLE TRASERA SUPERIOR
3	416			1									664 000 671	KABEL ANTRIEB UNTER	(FRANCE REDUCTEURS)	CABLE, REAR DRIVE LOWER	CABLE TRACTION INFERIEURE	CABLE TRASERA INFERIOR
3	417			1									664 246 031	VERBINDUNG OBEN		LOWER JOINT	CONNECTION INF	CONEXIÓN INFERIOR
3	418			1									664 042 040	ISOLATION KOMPASS		ISOLATION COMPASS	BOUSSOLE DE	COMPÁS AISLANTE
3	419			1									664 246 030	VERBINDUNG UNTEN		UPPER JOINT	CONNECTION SUP	CONEXIÓN SUPERIOR
3	420			1									664 001 150	KABEL, ANTRIEB OBER		CABLE, REAR DRIVE LOWER	CABLE TRACTION SUPERIEURE	CABLE TRASERA SUPERIOR
3	421			1									664 041 957	BUCHSE		BUSH	DOUILLE	CASQUILLO
3	422			1									664 450 063	FEDER		SPRING	RESSORT	RESORTE
3	423			1									664 680 009	SCHEIBE		WASHER	RONDELLE	ARANDELA
3	424			1									664 154 510	MUTTER		NUT	ECROU	TUERCA
3	425			1									664 110 230	GUMMISTOPFEN		CAP	BOUCHON	TAPÓN
3	451			1									664 785 210	HALTER, HAUBE		SUPPORT, COVER	SUPPORT CAPOT	SOPORTE, CUBIERTA
3	452			4									664 728 710	SCHRAUBE		SCREW	VIS	TORNILLO
3	453			1									664 563 641	MOTOR	1800 W	MOTOR	MOTEUR	MOTOR
3	453,1			1									664 740 054	LÜFTER MOTOR ATB		FAN MOTOR ATB	VENTILATEUR MOTEUR ATB	VENTILADOR MOTOR ATB
3	453,2			1									664 222 039	KONDENSATOR	25 µF	CONDENSER	CONDENSEUR	CONDENSADOR
3	454			4									664 735 410	SCHRAUBE		SCREW	VIS	TORNILLO
3	455			4									664 583 500	FEDERRING		GROWER	GROWER	ARANDELA DE PRESIÓN

Seite / Page	Pos.	EM-3310	EM-3713	EM-4316 S	EM-4816	PM-43	PM-48	PM-48 S	PM-480 S	PM-4850	PM-4850 S	PM-5150 S	Teil-Nr. Part No. No. de pièce No. de pieza	Bezeichnung	Spezifikation Specification	Description	Désignation	Denominación
3	456			4									664 293 200	6KT-MUTTER	M8	NUT	ECROU	TUERCA
3	457			1									664 207 211	FLANSCH		FLANGE	BRIDE	BRIDA
3	458			1									664 720 360	LÜFTUNGSSCHIRM		VENTILATION SCREEN	ECRAN VENTILATION	PANTALLA DE VENTILACIÓN
3	459			4									664 691 800	SCHRAUBE		SCREW	VIS	TORNILLO
3	460			1									664 139 440	KEIL		FEATHER	CLAVETTE	CHAVETA
3	461			1									664 170 960	DISTANZRING		SPACER	ENTRETOISE	DISTANCIADOR
3	501			1									664 463 186	MESSERHALTER		HUB	MOYEU	SOPORTE DE LA CUCHILLA
3	502			1									664 531 043	MESSER	43 CM	BLADE	LAME	CUCHILLA ESTÁNDAR
3	503			2									664 583 500	FEDERRING		GROWER	GROWER	ARANDELA DE PRESIÓN
3	504			2									664 793 101	SCHRAUBE		SCREW	VIS	TORNILLO
3	505			1									664 004 352	MESSERSCHRAUBE		SCREW	VIS	TORNILLO
3	506			1									664 713 801	STIFT		PIN	GOUPILLE	PASADOR
3	507			1									664 601 911	RIEMENSCHLEIBE		PULLEY	POUILE	POLEA
3	601			1									664 486 101	KORB, OBERTEIL		GRASS-BOX, UPPER	SAC, PARTIE	CESTO, SUPERIOR
3	602			1									664 608 525	VERSTÄRKUNG		STIFFENING LOWER	RÉNFORCEMENT INF	REFUERZO INFERIOR
3	603			1									664 002 211	SACK, TUCH		BOX, FABRIC	SAC, TOILE	CESTO, TELA
3	604			2									664 728 680	SCHRAUBE		SCREW	VIS	TORNILLO
3	605			2									664 523 050	SCHEIBE		WASHER	RONDELLE	ARANDELA

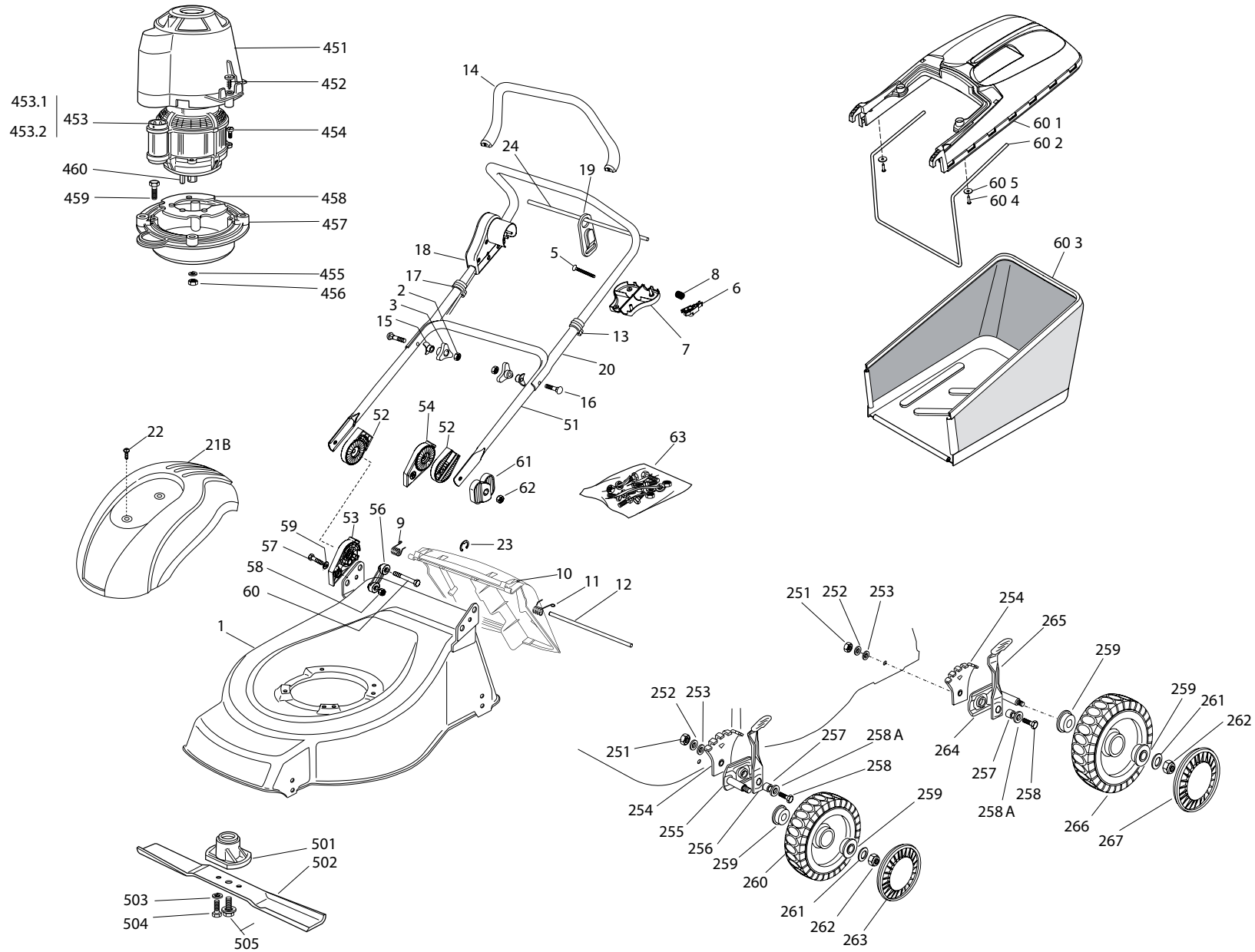

Seite / Page	Pos.	EM-3310	EM-3713	EM-4316 S	EM-4816	PM-43	PM-48	PM-480 S	PM-4850	PM-5150 S	Teil-Nr. Part No. No. de pièce No. de pieza	Bezeichnung	Spezifikation Specification	Description	Désignation	Denominación
4	1				1						664 002 720	GEHAUSE ROT		DECK RED	CHASSIS ROUGE	CAJA ROJA
4	2				2						664 293 200	6KT-MUTTER	M8	NUT	ECROU	TUERCA
4	3				2						664 399 900	GRIFF		KNOB	POIGNÉE	MANETA
4	4				1						664 034 601	SCHUTZ		PROTECTION	PROTECTION	PROTECCIÓN
4	5				4						664 728 685	SCHRAUBE		SCREW	VIS	TORNILLO
4	6				1						664 230 350	GELENKPUNKT		FULCRUM PIN	POINT D'APPUI	PUNTO DE ARTICULACIÓN
4	7				1						664 785 144	HALTER		SUPPORT	SUPPORT	SOPORTE
4	8				1						664 450 115	FEDER		SPRING	RESSORT	RESORTE
4	9				1						664 450 410	FEDER RECHTS		RIGHT SPRING	RESSORT D	RESORTE DER.
4	10				1						664 600 063	PRALLBLECH		STONE-GUARD	PARE-PIERRES	CUBIERTA PROTECTORA
4	11				1						664 450 420	FEDER LINKS		L SPRING	RESSORT G	RESORTE IZQ.
4	12				1						664 517 906	STANGE		PIN	PIVOT	PASADOR
4	13				1						664 192 151	KABELBEFESTIGUNG		FAIRLEAD	FIXATION CABLE	SUJETACABLE
4	14				1						664 322 881	HEBEL MOTORBREMSE		LEVER, MOTOR BRAKE	LEVIER FREIN MOTEUR	PALANCA, FRENO MOTOR
4	15				2						664 680 006	SCHEIBE		WASHER	RONDELLE	ARANDELA
4	16				2						664 819 201	SCHRAUBE		SCREW	VIS	TORNILLO
4	17				1						664 192 000	BOWDENZUGHALTER		ANCHOR CLAMP	COLLIER ANCRAGE	GRAPA DE SUJECCIÓN
4	18				1						664 600 503	TOTMANN-SCHALTER		DEAD HAND SWITCH	INT. MAIN MORTE	INTERRUPTOR DE HOMBRE MUERTO
4	19				1						664 195 101	KABELBEFESTIGUNG		FAIRLEAD	FIXATION CABLE	SUJETACABLE
4	20				1						664 007 017	HOLM, OBERTEIL		HANDLE, UPPER PART	MANCHERON, PARTIE SUPERIEURE	MANILLAR, PARTE SUPERIOR
4	21B				1						664 055 065	HAUBE		COVER	CAPOT	CUBIERTA
4	22				2						664 728 680	SCHRAUBE		SCREW	VIS	TORNILLO
4	23				1						664 000 930	SPRENGRING		SNAP RING	ANNEAU RESSORT	ANILLO DE SUJECCIÓN
4	24				1						664 010 251	KABELHALTER		FAIRLEAD BEARING	SUPPORT SERRECABLE	SOPORTE SUJETACABLE
4	51				1						664 006 532	HOLM, UNTERTEIL		HANDLE, LOWER PART	MANCHERON, PARTIE INFERIEURE	MANILLAR, PARTE INFERIOR
4	52				2						664 785 081	HALTER, AUßEN		SUPPORT, EXTERNAL	SUPPORT EXTERNE	SOPORTE, EXTERIOR
4	53				1						664 785 082	HALTER, INNEN R		SUPPORT, R INTERNAL	SUPPORT INTERNE D	SOPORTE INTERIOR, DER.
4	54				1						664 785 083	HALTER, INNEN L		SUPPORT, L INTERNAL	SUPPORT INTERNE G	SOPORTE INTERIOR, IZQ.
4	56				2						664 551 575	PLATTE, INNEN		PLATE, INSIDE	PLAQUETTE INTERNE	PLANCHA, INTERIOR
4	57				2						664 793 701	SCHRAUBE		SCREW	VIS	TORNILLO
4	58				2						664 155 000	MUTTER		NUT	ECROU	TUERCA
4	59				2						664 521 350	SCHEIBE		WASHER	RONDELLE	ARANDELA
4	60				2						664 691 810	SCHRAUBE		SCREW	VIS	TORNILLO
4	61				2						664 399 803	GRIFF		KNOB	POIGNÉE	MANETA
4	62				2						664 293 202	MUTTER		NUT	ECROU	TUERCA
4	63				1						664 008 622	SATZ SCHRAUBEN		OUTFIT, SCREWS	DOTATION VISSERIE	JUEGO DE TORNILLOS
4	251				4						664 293 200	6KT-MUTTER	M8	NUT	ECROU	TUERCA
4	252				4						664 583 500	FEDERRING		GROWER	GROWER	ARANDELA DE PRESIÓN
4	253				4						664 523 070	SCHEIBE		WASHER	RONDELLE	ARANDELA
4	254				4						664 735 547	SEKTOR, HÖHENVERSTELLUNG		SECTOR, HEIGHT ADJUSTMENT	SECTEUR REGLAGE HAUTEUR	SECTOR, AJUSTE ALTURA
4	255				2						664 005 082	RADHALTER		SUPPORT, WHEEL	SUPPORT ROUE	SOPORTE, RUEDA
4	256				2						664 003 285	HEBEL, HÖHENVERSTELLUNG		LEVER, HEIGHT ADJUSTMENT	LEVIER, REGLAGE HAUTEUR	PALANCA, AJUSTE ALTURA
4	257				4						664 171 001	DISTANZRING		SPACER	ENTRETOISE	DISTANCIADOR
4	258				4						664 793 701	SCHRAUBE		SCREW	VIS	TORNILLO
4	258A				4						664 521 350	SCHEIBE		WASHER	RONDELLE	ARANDELA
4	259				8						664 034 508	BUCHSE		BUSH	DOUILLE	CASQUILLO
4	260				2						664 007 336	RAD MIT STOLLENPROFIL	Ø 170	WHEEL, KNOBBLY	ROUE SCULPTEE	RUEDA CON PERFIL
4	261				4						664 523 060	SCHEIBE		WASHER	RONDELLE	ARANDELA
4	262				4						664 155 000	MUTTER		NUT	ECROU	TUERCA
4	263				2						664 110 304	RADKAPPE ROT		HUB CAP RED	COUVRE-MOYEU ROUGE	TAPACUBOS ROJO

Seite / Page	Pos.	EM-3310	EM-3713	EM-4316 S	EM-4816	PM-43	PM-48	PM-48 S	PM-480 S	PM-4850	PM-4850 S	PM-5150 S	Teil-Nr. Part No. No. de pièce No. de pieza	Bezeichnung	Spezifikation Specification	Description	Désignation	Denominación
4	264				2								664 005 084	HALTER, RAD		SUPPORT, WHEEL	SUPPORT ROUE	SOPORTE, RUEDA
4	265				2								664 003 286	HEBEL, HOHENVERSTELLUNG		LEVER, HEIGHT ADJUSTMENT	LEVIER, REGLAGE HAUTEUR	PALANCA, AJUSTE ALTURA
4	266				2								664 007 337	RAD MIT STOLLENPROFIL	Ø 210	WHEEL, KNOBBLY	ROUE SCULPTEE	RUEDA CON PERFIL
4	267				2								664 110 305	RADKAPPE ROT		HUB CAP RED	COUVRE-MOYEU ROUGE	TAPACUBOS ROJO
4	451				1								664 785 061	HALTER, HAUBE		SUPPORT, COVER	SUPPORT CAPOT	SOPORTE, CUBIERTA
4	452				4								664 728 710	SCHRAUBE		SCREW	VIS	TORNILLO
4	453				1								664 563 009	MOTOR RST	1600 W	MOTOR RST	MOTEUR RST	MOTOR RST
4	453				1								664 563 605	MOTOR ATB	1600 W	MOTOR ATB	MOTEUR ATB	MOTOR ATB
4	453,1				1								664 740 051	LÜFTER RST MOTOR		FAN	VENTILATEUR MOTEUR RST	VENTILADOR MOTOR RST
4	453,1				1								664 740 054	LÜFTER MOTOR ATB		FAN MOTOR ATB	VENTILATEUR MOTEUR ATB	VENTILADOR MOTOR ATB
4	453,2				1								664 222 045	KONDENSATOR	(ATB)	CONDENSER	CONDENSEUR	CONDENSADOR
4	453,2				1								664 222 038	KONDENSATOR	(RST)	CONDENSER	CONDENSEUR	CONDENSADOR
4	454				4								664 735 410	SCHRAUBE		SCREW	VIS	TORNILLO
4	455				4								664 583 500	FEDERRING		GROWER	GROWER	ARANDELA DE PRESIÓN
4	456				4								664 293 200	MUTTER		NUT	ECROU	TUERCA
4	457				1								664 207 211	FLANSCH		FLANGE	BRIDE	BRIDA
4	458				1								664 720 360	LÜFTUNGSSCHIRM		VENTILATION SCREEN	ECRAN VENTILATION	PANTALLA DE VENTILACIÓN
4	459				4								664 793 700	SCHRAUBE	M8X30	SCREW	VIS	TORNILLO
4	460				1								664 139 440	KEIL		FEATHER	CLAVETTE	CHAVETA
4	501				1								664 463 186	MESSERHALTER		HUB	MOYEU	SOPORTE DE LA CUCHILLA
4	502				1								664 531 048	MESSER	48 CM	BLADE	LAME	CUCHILLA ESTÁNDAR
4	503				2								664 583 500	FEDERRING		GROWER	GROWER	ARANDELA DE PRESIÓN
4	504				2								664 793 101	SCHRAUBE		SCREW	VIS	TORNILLO
4	505				1								664 004 352	MESSERSCHRAUBE		SCREW	VIS	TORNILLO
4	601				1								664 486 101	KORB, OBERTEIL		GRASS-BOX, UPPER	SAC, PARTIE	CESTO, SUPERIOR
4	602				1								664 608 525	VERSTÄRKUNG		STIFFENING LOWER	RÉNFORCEMENT INF	REFUERZO INFERIOR
4	603				1								664 002 211	SACK, TUCH		BOX, FABRIC	SAC, TOILE	CESTO, TELA
4	604				2								664 728 680	SCHRAUBE		SCREW	VIS	TORNILLO
4	605				2								664 523 050	SCHEIBE		WASHER	RONDELLE	ARANDELA

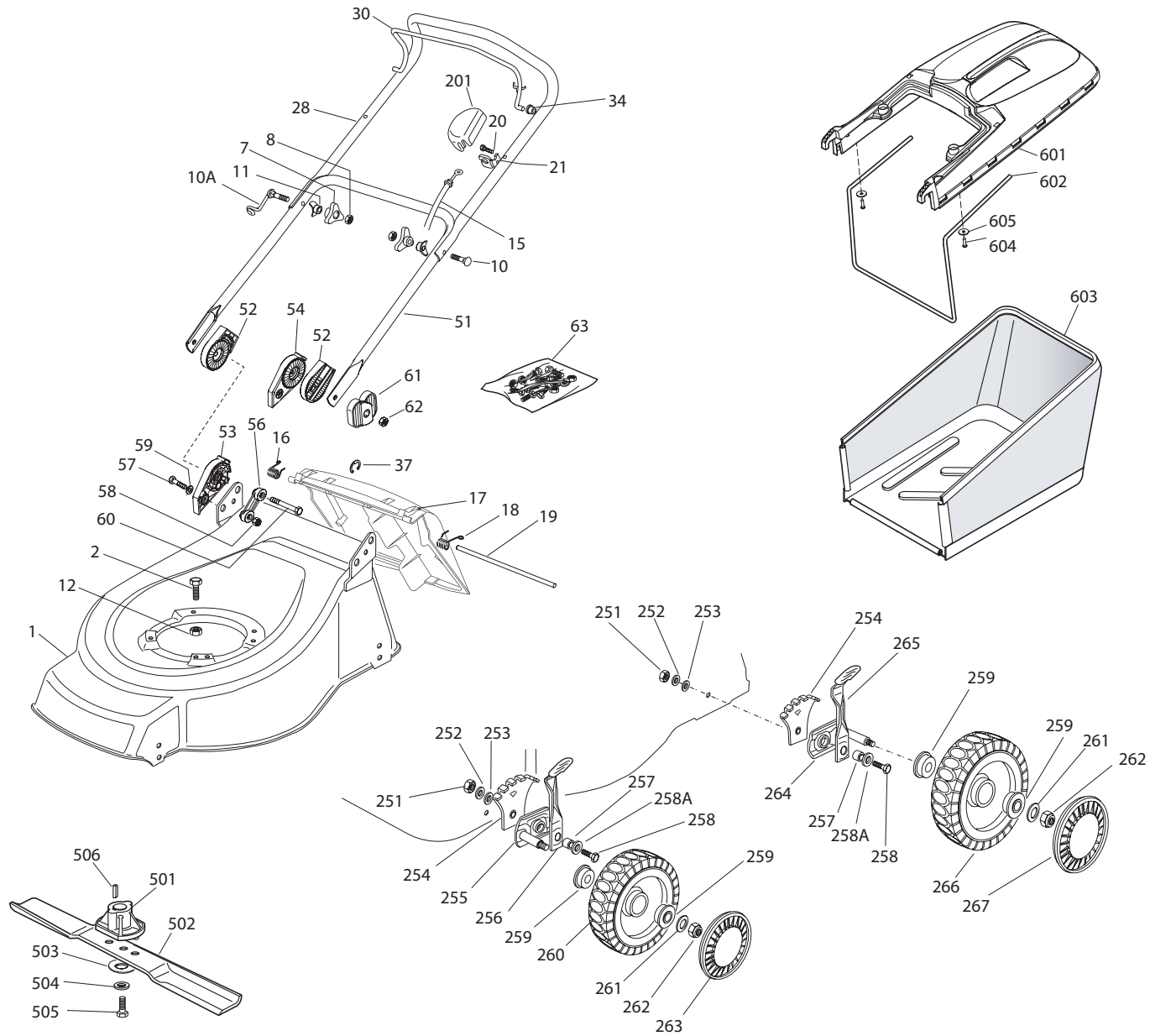

Seite / Page	Pos.	EM-3310	EM-3713	EM-4316 S	EM-4816	PM-43	PM-48	PM-48 S	PM-480 S	PM-4850	PM-4850 S	PM-5150 S	Teil-Nr. Part No. No. de pièce No. de pieza	Bezeichnung	Spezifikation Specification	Description	Désignation	Denominación
5 1					1								664 002 362	GEHAUSE ROT		DECK RED	CHASSIS ROUGE	CAJA ROJA
5 2					0/1								664 691 800	SCHRAUBE		SCREW	VIS	TORNILLO
5 2					3/2								664 793 701	SCHRAUBE		SCREW	VIS	TORNILLO
5 7					2								664 399 900	GRIFF		KNOB	POIGNÉE	MANETA
5 8					2								664 293 200	MUTTER		NUT	ECROU	TUERCA
5 10					1								664 819 201	SCHRAUBE		SCREW	VIS	TORNILLO
5 10A					1								664 003 801	FEDER		SPRING	RESSORT	RESORTE
5 11					2								664 680 006	SCHEIBE		WASHER	RONDELLE	ARANDELA
5 12					0/1								664 155 000	MUTTER		NUT	ECROU	TUERCA
5 12					3/2								664 293 201	MUTTER		NUT	ECROU	TUERCA
5 15					1								664 000 625	KABEL, MOTORBREMSE	(B&S CLASSIC/SPRINT/LS/LC)	CABLE, THREAD MOTOR BRAKE	CABLE FREIN MOTEUR	CABLE, FRENO MOTOR
5 16					1								664 450 410	FEDER RECHTS		RIGHT SPRING	RESSORT D	RESORTE DER.
5 17					1								664 600 063	PRALLBLECH		STONE-GUARD	PARE-PIERRES	CUBIERTA PROTECTORA
5 18					1								664 450 420	FEDER LINKS		L SPRING	RESSORT G	RESORTE IZQ.
5 19					1								664 517 906	STANGE		PIN	PIVOT	PASADOR
5 20					1								664 728 518	SCHRAUBE		SCREW	VIS	TORNILLO
5 21					1								664 806 612	HALTER		SUPPORT	SUPPORT	SOPORTE
5 28					1								664 007 018	OBERHOLM		HANDLE, UPPER PART	MANCHERON, PARTIE SUPERIEURE	MANILLAR, PARTE SUPERIOR
5 30					1								664 003 291	HEBEL, MOTORBREMSE		LEVER, MOTOR BRAKE	LEVIER FREIN MOTEUR	PALANCA, FRENO MOTOR
5 34					2								664 041 966	BUCHSE		BUSH	DOUILLE	CASQUILLO
5 37					1								664 000 930	SPRENGRING		SNAP RING	ANNEAU RESSORT	ANILLO DE SUJECIÓN
5 51					1								664 006 532	HOLM, UNTERTEIL		HANDLE, LOWER PART	MANCHERON, PARTIE INFERIEURE	MANILLAR, PARTE INFERIOR
5 52					2								664 785 081	HALTER, AUßEN		SUPPORT, EXTERNAL	SUPPORT EXTERNE	SOPORTE, EXTERIOR
5 53					1								664 785 082	HALTER, INNEN R		SUPPORT, R INTERNAL	SUPPORT INTERNE D	SOPORTE INTERIOR, DER.
5 54					1								664 785 083	HALTER, INNEN L		SUPPORT, L INTERNAL	SUPPORT INTERNE G	SOPORTE INTERIOR, IZQ.
5 56					2								664 551 575	PLATTE, INNEN		PLATE, INSIDE	PLAQUETTE INTERNE	PLANCHA, INTERIOR
5 57					2								664 793 701	SCHRAUBE		SCREW	VIS	TORNILLO
5 58					2								664 155 000	MUTTER		NUT	ECROU	TUERCA
5 59					2								664 521 350	SCHEIBE		WASHER	RONDELLE	ARANDELA
5 60					2								664 691 810	SCHRAUBE		SCREW	VIS	TORNILLO
5 61					2								664 399 803	GRIFF		KNOB	POIGNÉE	MANETA
5 62					2								664 293 202	MUTTER		NUT	ECROU	TUERCA
5 63					1								664 008 623	SATZ, SCHRAUBEN		OUTFIT, SCREWS	DOTATION VISSERIE	JUEGO DE TORNILLOS
5 201					1								664 601 000	SCHUTZ		PROTECTION	PROTECTION	PROTECCIÓN
5 251					4								664 293 200	MUTTER		NUT	ECROU	TUERCA
5 252					4								664 583 500	FEDERRING		GROWER	GROWER	ARANDELA DE PRESIÓN
5 253					4								664 523 070	SCHEIBE		WASHER	RONDELLE	ARANDELA
5 254					4								664 735 547	SEKTOR, HOHENVERSTELLUNG		SECTOR, HEIGHT ADJUSTMENT	SECTEUR REGLAGE HAUTEUR	SECTOR, AJUSTE ALTURA
5 255					2								664 005 082	HALTER, RAD		SUPPORT, WHEEL	SUPPORT ROUE	SOPORTE, RUEDA
5 256					2								664 003 285	HEBEL, HOHENVERSTELLUNG		LEVER, HEIGHT ADJUSTMENT	LEVIER, REGLAGE HAUTEUR	PALANCA, AJUSTE ALTURA
5 257					4								664 171 001	DISTANZRING		SPACER	ENTRETOISE	DISTANCIADOR
5 258					4								664 793 701	SCHRAUBE		SCREW	VIS	TORNILLO
5 258A					4								664 521 350	SCHEIBE		WASHER	RONDELLE	ARANDELA
5 259					8								664 034 508	BUCHSE		BUSH	DOUILLE	CASQUILLO
5 260					2								664 007 336	RAD MIT STOLLENPROFIL	Ø 170	WHEEL, KNOBBLY	ROUE SCULPTEE	RUEDA CON PERFIL
5 261					4								664 523 060	SCHEIBE		WASHER	RONDELLE	ARANDELA
5 262					4								664 155 000	MUTTER		NUT	ECROU	TUERCA
5 263					2								664 110 304	RADKAPPE ROT		HUB CAP RED	COUVRE-MOYEU ROUGE	TAPACUBOS ROJO
5 264					2								664 005 084	HALTER, RAD		SUPPORT, WHEEL	SUPPORT ROUE	SOPORTE, RUEDA
5 265					2								664 003 286	HEBEL, HOHENVERSTELLUNG		LEVER, HEIGHT ADJUSTMENT	LEVIER, REGLAGE HAUTEUR	PALANCA, AJUSTE ALTURA

DOLMAR

Seite / Page	Pos.	EM-3310	EM-3713	EM-4316 S	EM-4816	PM-43	PM-48	PM-48 S	PM-480 S	PM-4850	PM-4850 S	PM-5150 S	Teil-Nr. Part No. No. de pièce No. de pieza	Bezeichnung	Spezifikation Specification	Description	Désignation	Denominación
5	266					2							664 007 337	RAD MIT STOLLENPROFIL	Ø 210	WHEEL, KNOBBLY	ROUE SCULPTEE	RUEDA CON PERFIL
5	267					2							664 110 305	RADKAPPE ROT		HUB CAP RED	COUVRE-MOYEU ROUGE	TAPACUBOS ROJO
5	501					1							664 463 012	MESSERKUPPLUNG		HUB	MOYEU	SOPORTE DE LA CUCHILLA
5	502					1							664 531 043	MESSER	43CM	BLADE	LAME	CUCHILLA ESTÁNDAR
5	503					1							664 160 400	TELLERFEDER		ELASTIC WASHER	RONDELLE ELASTIQUE	ARANDELA ELÁSTICA
5	504					1							664 523 080	SCHEIBE		WASHER	RONDELLE	ARANDELA
5	505					1							664 735 698	SCHRAUBE		SCREW	VIS	TORNILLO
5	506					1							664 139 100	KEIL		FEATHER	CLAVETTE	CHAVETA
5	601					1							664 486 101	KORB, OBERTEIL		GRASS-BOX, UPPER	SAC, PARTIE	CESTO, SUPERIOR
5	602					1							664 608 525	VERSTÄRKUNG		STIFFENING LOWER	RÉNFORCEMENT INF	REFUERZO INFERIOR
5	603					1							664 002 211	SACK, TUCH		BOX, FABRIC	SAC, TOILE	CESTO, TELA
5	604					2							664 728 680	SCHRAUBE		SCREW	VIS	TORNILLO
5	605					2							664 523 050	SCHEIBE		WASHER	RONDELLE	ARANDELA

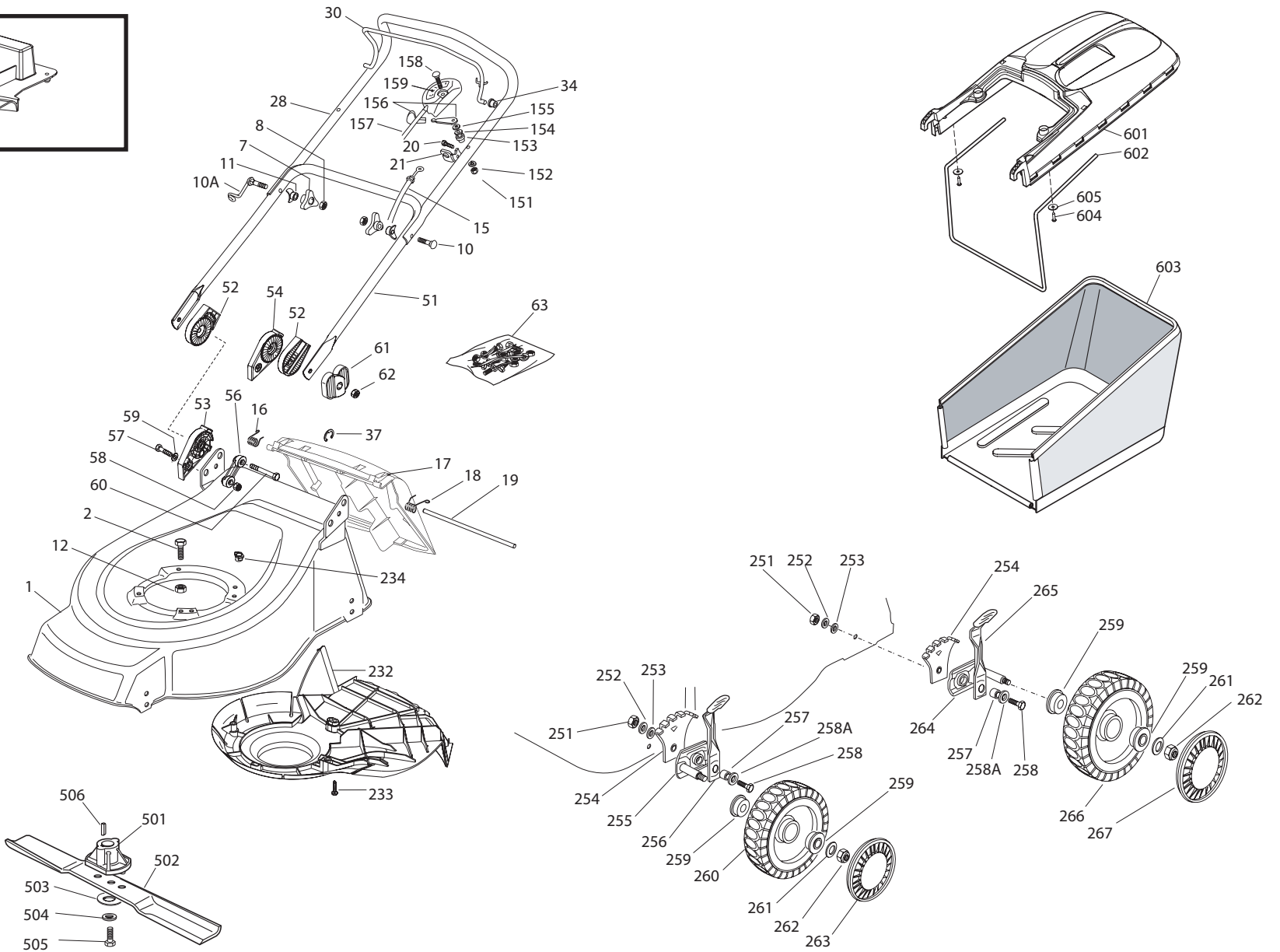
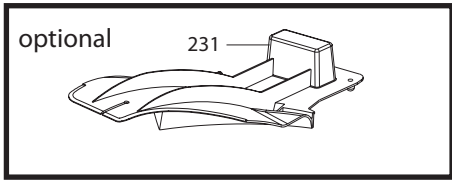

Seite / Page	Pos.	EM-3310	EM-3713	EM-4316 S	EM-4816	PM-43	PM-48	PM-48 S	PM-480 S	PM-4850	PM-4850 S	PM-5150 S	Teil-Nr. Part No. No. de pièce No. de pieza	Bezeichnung	Spezifikation Specification	Description	Désignation	Denominación
6 1							1						664 002 720	GEHAUSE ROT		DECK RED	CHASSIS ROUGE	CAJA ROJA
6 2							0/1						664 691 800	SCHRAUBE		SCREW	VIS	TORNILLO
6 2							3/2						664 793 701	SCHRAUBE		SCREW	VIS	TORNILLO
6 7							2						664 399 900	GRIFF		KNOB	POIGNÉE	MANETA
6 8							2						664 293 200	MUTTER		NUT	ECROU	TUERCA
6 10							1						664 819 201	SCHRAUBE		SCREW	VIS	TORNILLO
6 10A							1						664 003 801	HOLMFEDER		SPRING	RESSORT	RESORTE
6 11							2						664 680 006	SCHEIBE		WASHER	RONDELLE	ARANDELA
6 12							0/1						664 155 000	MUTTER		NUT	ECROU	TUERCA
6 12							3/2						664 293 201	MUTTER		NUT	ECROU	TUERCA
6 15							1						664 000 625	KABEL MOTORBREMSE	(B&S CLASSIC/SPRINT/LS/LC)	CABLE, THREAD MOTOR BRAKE	CABLE FREIN MOTEUR	CABLE, FRENO MOTOR
6 16							1						664 450 410	FEDER RECHTS		RIGHT SPRING	RESSORT D	RESORTE DER.
6 17							1						664 600 063	PRALLBLECH		STONE-GUARD	PARE-PIERRES	CUBIERTA PROTECTORA
6 18							1						664 450 420	FEDER LINKS		L SPRING	RESSORT G	RESORTE IZQ.
6 19							1						664 517 906	STANGE		PIN	PIVOT	PASADOR
6 20							1						664 728 518	SCHRAUBE		SCREW	VIS	TORNILLO
6 21							1						664 806 612	HALTER		SUPPORT	SUPPORT	SOPORTE
6 28							1						664 007 018	OBERHOLM		HANDLE, UPPER PART	MANCHERON, PARTIE SUPERIEURE	MANILLAR, PARTE SUPERIOR
6 30							1						664 003 291	HEBEL, MOTORBREMSE		LEVER, MOTOR BRAKE	LEVIER FREIN MOTEUR	PALANCA, FRENO MOTOR
6 34							2						664 041 966	BUCHSE		BUSH	DOUILLE	CASQUILLO
6 37							1						664 000 930	SPRENGRING		SNAP RING	ANNEAU RESSORT	ANILLO DE SUJECIÓN
6 51							1						664 006 532	HOLM, UNTERTEIL		HANDLE, LOWER PART	MANCHERON, PARTIE INFERIEURE	MANILLAR, PARTE INFERIOR
6 52							2						664 785 081	HALTER, AUßEN		SUPPORT, EXTERNAL	SUPPORT EXTERNE	SOPORTE, EXTERIOR
6 53							1						664 785 082	HALTER, INNEN R		SUPPORT, R INTERNAL	SUPPORT INTERNE D	SOPORTE INTERIOR, DER.
6 54							1						664 785 083	HALTER, INNEN L		SUPPORT, L INTERNAL	SUPPORT INTERNE G	SOPORTE INTERIOR, IZQ.
6 56							2						664 551 575	PLATTE, INNEN		PLATE, INSIDE	PLAQUETTE INTERNE	PLANCHA, INTERIOR
6 57							2						664 793 701	SCHRAUBE		SCREW	VIS	TORNILLO
6 58							2						664 155 000	MUTTER		NUT	ECROU	TUERCA
6 59							2						664 521 350	SCHEIBE		WASHER	RONDELLE	ARANDELA
6 60							2						664 691 810	SCHRAUBE		SCREW	VIS	TORNILLO
6 61							2						664 399 803	GRIFF		KNOB	POIGNÉE	MANETA
6 62							2						664 293 202	MUTTER		NUT	ECROU	TUERCA
6 63							1						664 008 623	SATZ, SCHRAUBEN		OUTFIT, SCREWS	DOTATION VISSERIE	JUEGO DE TORNILLOS
6 151							1						664 291 000	MUTTER		NUT	ECROU	TUERCA
6 152							1						664 581 500	FEDERRING		GROWER	GROWER	ARANDELA DE PRESIÓN
6 153							1						664 171 005	DISTANZRING		SPACER	ENTRETOISE	DISTANCIADOR
6 154							1						664 521 360	SCHEIBE		WASHER	RONDELLE	ARANDELA
6 155							1						664 508 100	FEDERSCHEIBE		SPRING WASHER	RONDELLE ELASTIQUE	ARANDELA ELÁSTICA
6 156							1						664 007 279	HEBEL, BESCHLEUNIGER		LEVER, THROTTLE	LEVIER	PALANCA, ACELERADOR
6 157							1						664 007 080	MOTORFERNBEDIENUNG (SATZ)		CABLE, TROTTLE	CABLE, ACCELERATEUR	CABLE, ACELERADOR
6 158							1						664 815 000	SCHRAUBE		SCREW	VIS	TORNILLO
6 159							1						664 356 703	SCHILD	(B&S)	LABEL	ETIQUETTE	ETIQUETA
6 231							1						664 140 223	MULCHEINSATZ	optional for MULCHING	MULCH PLUG	INSERT MULCH	TAPA
6 232							1						664 060 198	SCHUTZ		PROTECTION	PROTECTION	PROTECCIÓN
6 233							3						664 728 530	SCHRAUBE		SCREW	VIS	TORNILLO
6 234							1						664 291 150	GUMMIEINSATZ		RUBBER INSERT	INSERT DE	INSERTO DE CAUCHO
6 251							4						664 293 200	MUTTER		NUT	ECROU	TUERCA
6 252							4						664 583 500	FEDERRING		GROWER	GROWER	ARANDELA DE PRESIÓN
6 253							4						664 523 070	SCHEIBE		WASHER	RONDELLE	ARANDELA
6 254							4						664 735 547	SEKTOR, HÖHENVERSTELLUNG		SECTOR, HEIGHT ADJUSTMENT	SECTEUR REGLAGE HAUTEUR	SECTOR, AJUSTE ALTURA

Seite / Page	Pos.	EM-3310	EM-3713	EM-4316 S	EM-4816	PM-43	PM-48	PM-48 S	PM-480 S	PM-4850	PM-4850 S	PM-5150 S	Teil-Nr. Part No. No. de pièce No. de pieza	Bezeichnung	Spezifikation Specification	Description	Désignation	Denominación
6	255						2						664 005 082	RADHALTER		SUPPORT, WHEEL	SUPPORT ROUE	SOPORTE, RUEDA
6	256						2						664 003 285	HEBEL, HOHENVERSTELLUNG		LEVER, HEIGHT ADJUSTMENT	LEVIER, REGLAGE HAUTEUR	PALANCA, AJUSTE ALTURA
6	257						4						664 171 001	DISTANZRING		SPACER	ENTRETOISE	DISTANCIADOR
6	258						4						664 793 701	SCHRAUBE		SCREW	VIS	TORNILLO
6	258A						4						664 521 350	SCHEIBE		WASHER	RONDELLE	ARANDELA
6	259						8						664 034 508	BUCHSE		BUSH	DOUILLE	CASQUILLO
6	260						2						664 007 336	RAD MIT STOLLENPROFIL	Ø 170	WHEEL, KNOBBLY	ROUE SCULPTEE	RUEDA CON PERFIL
6	261						4						664 523 060	SCHEIBE		WASHER	RONDELLE	ARANDELA
6	262						4						664 155 000	MUTTER		NUT	ECROU	TUERCA
6	263						2						664 110 304	RADKAPPE ROT		HUB CAP RED	COUVRE-MOYEU ROUGE	TAPACUBOS ROJO
6	264						2						664 005 084	HALTER, RAD		SUPPORT, WHEEL	SUPPORT ROUE	SOPORTE, RUEDA
6	265						2						664 003 286	HEBEL, HOHENVERSTELLUNG		LEVER, HEIGHT ADJUSTMENT	LEVIER, REGLAGE HAUTEUR	PALANCA, AJUSTE ALTURA
6	266						2						664 007 337	RAD MIT STOLLENPROFIL	Ø 210	WHEEL, KNOBBLY	ROUE SCULPTEE	RUEDA CON PERFIL
6	267						2						664 110 305	RADKAPPE ROT		HUB CAP RED	COUVRE-MOYEU ROUGE	TAPACUBOS ROJO
6	501						1						664 463 012	MESSERKUPPLUNG		HUB	MOYEU	SOPORTE DE LA CUCHILLA
6	502						1						664 531 048	MESSER	48 CM	BLADE	LAME	CUCHILLA ESTÁNDAR
6	503						1						664 160 400	TELLERFEDER		ELASTIC WASHER	RONDELLE ELASTIQUE	ARANDELA ELÁSTICA
6	504						1						664 523 080	SCHEIBE		WASHER	RONDELLE	ARANDELA
6	505						1						664 735 698	SCHRAUBE		SCREW	VIS	TORNILLO
6	506						1						664 139 100	SCHEIBENFEDER		FEATHER	CLAVETTE	CHAVETA
6	601						1						664 486 101	KORB, OBERTEIL		GRASS-BOX, UPPER	SAC, PARTIE	CESTO, SUPERIOR
6	602						1						664 608 525	VERSTÄRKUNG		STIFFENING LOWER	RÉNFORCEMENT INF	REFUERZO INFERIOR
6	603						1						664 002 211	SACK, TUCH		BOX, FABRIC	SAC, TOILE	CESTO, TELA
6	604						2						664 728 680	SCHRAUBE		SCREW	VIS	TORNILLO
6	605						2						664 523 050	SCHEIBE		WASHER	RONDELLE	ARANDELA

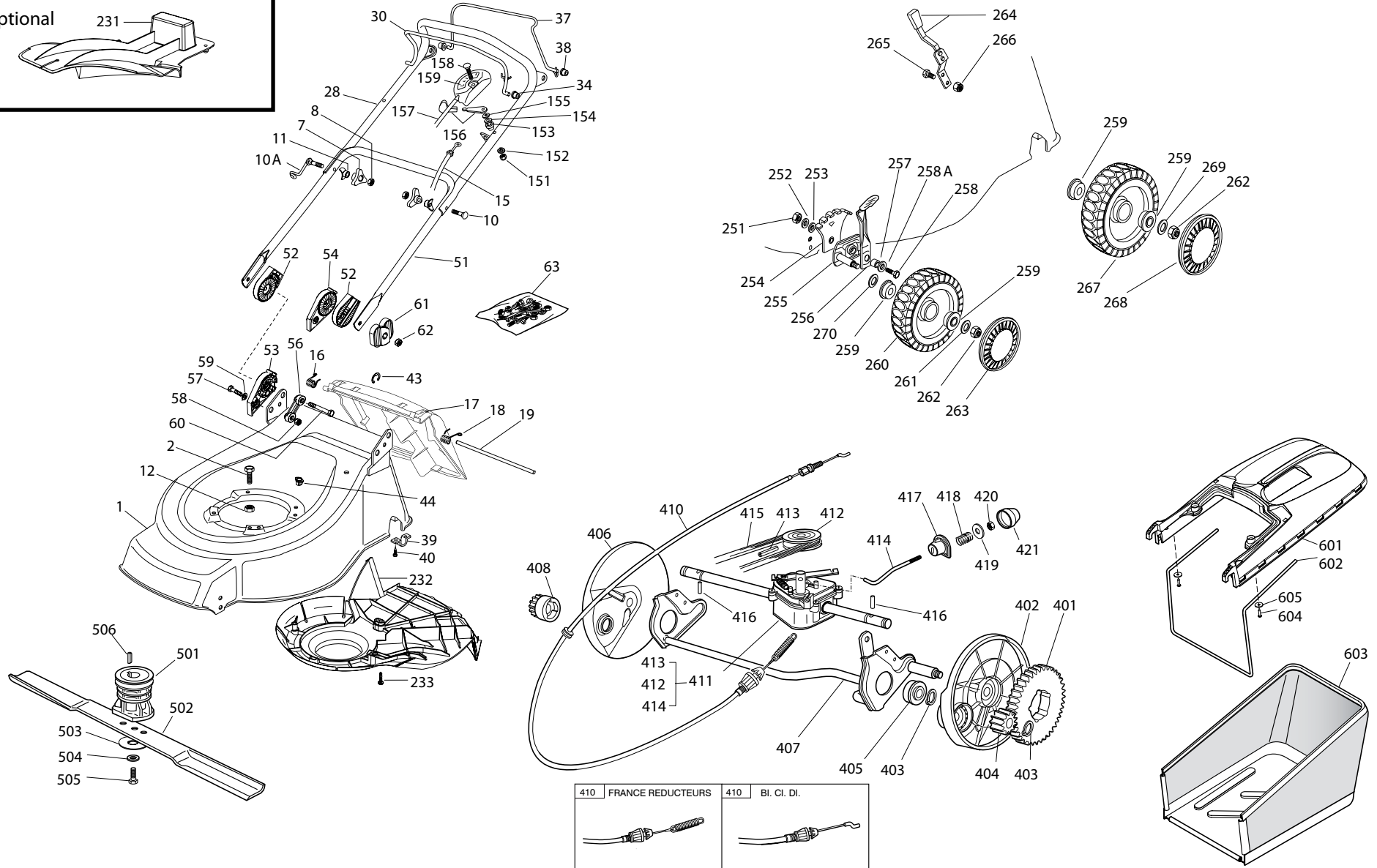
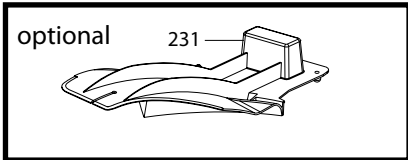



Seite / Page	Pos.	EM-3310	EM-3713	EM-4316 S	EM-4816	PM-43	PM-48	PM-48 S	PM-480 S	PM-4850	PM-4850 S	PM-5150 S	Teil-Nr. Part No. No. de pièce No. de pieza	Bezeichnung	Spezifikation Specification	Description	Désignation	Denominación
7 1							1						664 002 721	GEHAUSE ROT		DECK RED	CHASSIS ROUGE	CAJA ROJA
7 2							0/1						664 691 800	SCHRAUBE		SCREW	VIS	TORNILLO
7 2							3/2						664 793 701	SCHRAUBE		SCREW	VIS	TORNILLO
7 7							2						664 399 900	GRIFF		KNOB	POIGNÉE	MANETA
7 8							2						664 293 200	MUTTER		NUT	ECROU	TUERCA
7 10							1						664 819 201	SCHRAUBE		SCREW	VIS	TORNILLO
7 10A							1						664 003 801	FEDER		SPRING	RESSORT	RESORTE
7 11							2						664 680 006	SCHEIBE		WASHER	RONDELLE	ARANDELA
7 12							0/1						664 155 000	MUTTER		NUT	ECROU	TUERCA
7 12							3/2						664 293 201	MUTTER		NUT	ECROU	TUERCA
7 15							1						664 000 625	KABEL, MOTORBREMSE	(B&S CLASSIC/SPRINT/LS/LC	CABLE, THREAD MOTOR BRAKE	CABLE FREIN MOTEUR	CABLE, FRENO MOTOR
7 16							1						664 450 410	FEDER RECHTS		RIGHT SPRING	RESSORT D	RESORTE DER.
7 17							1						664 600 063	PRALLBLECH		STONE-GUARD	PARE-PIERRES	CUBIERTA PROTECTORA
7 18							1						664 450 420	FEDER LINKS		L SPRING	RESSORT G	RESORTE IZQ.
7 19							1						664 517 906	STANGE		PIN	PIVOT	PASADOR
7 28							1						664 007 024	OBERHOLM		HANDLE, UPPER PART	MANCHERON, PARTIE SUPERIEURE	MANILLAR, PARTE SUPERIOR
7 30							1						664 003 291	HEBEL, MOTORBREMSE		LEVER, MOTOR BRAKE	LEVIER FREIN MOTEUR	PALANCA, FRENO MOTOR
7 34							2						664 041 966	BUCHSE		BUSH	DOUILLE	CASQUILLO
7 37							1						664 003 288	BÜGEL		LEVER, DRIVING	LEVIER TRACTION	PALANCA, CONDUCCIÓN
7 38							2						664 041 965	BUCHSE		BUSH	DOUILLE	CASQUILLO
7 39							2						664 545 152	LAGERSCHALE		PLATE	PLAQUETTE	COJINETE
7 40							4						664 731 350	SCHRAUBE		SCREW	VIS	TORNILLO
7 43							1						664 000 930	SPRENGRING		SNAP RING	ANNEAU RESSORT	ANILLO DE SUJECIÓN
7 44							1						664 291 150	GUMMIEINSATZ		RUBBER INSERT	INSERT DE	INSERTO DE CAUCHO
7 51							1						664 006 532	HOLM, UNTERTEIL		HANDLE, LOWER PART	MANCHERON, PARTIE INFERIEURE	MANILLAR, PARTE INFERIOR
7 52							2						664 785 081	HALTER, AUßEN		SUPPORT, EXTERNAL	SUPPORT EXTERNE	SOPORTE, EXTERIOR
7 53							1						664 785 082	HALTER, INNEN R		SUPPORT, R INTERNAL	SUPPORT INTERNE D	SOPORTE INTERIOR, DER.
7 54							1						664 785 083	HALTER, INNEN L		SUPPORT, L INTERNAL	SUPPORT INTERNE G	SOPORTE INTERIOR, IZQ.
7 56							2						664 551 575	PLATTE, INNEN		PLATE, INSIDE	PLAQUETTE INTERNE	PLANCHA, INTERIOR
7 57							2						664 793 701	SCHRAUBE		SCREW	VIS	TORNILLO
7 58							2						664 155 000	MUTTER		NUT	ECROU	TUERCA
7 59							2						664 521 350	SCHEIBE		WASHER	RONDELLE	ARANDELA
7 60							2						664 691 810	SCHRAUBE		SCREW	VIS	TORNILLO
7 61							2						664 399 803	GRIFF		KNOB	POIGNÉE	MANETA
7 62							2						664 293 202	MUTTER		NUT	ECROU	TUERCA
7 63							1						664 008 623	SATZ, SCHRAUBEN		OUTFIT, SCREWS	DOTATION VISSERIE	JUEGO DE TORNILLOS
7 151							1						664 291 000	MUTTER		NUT	ECROU	TUERCA
7 152							1						664 581 500	FEDERRING		GROWER	GROWER	ARANDELA DE PRESIÓN
7 153							1						664 171 005	DISTANZRING		SPACER	ENTRETOISE	DISTANCIADOR
7 154							1						664 521 360	SCHEIBE		WASHER	RONDELLE	ARANDELA
7 155							1						664 508 100	FEDERSCHEIBE		SPRING WASHER	RONDELLE ELASTIQUE	ARANDELA ELÁSTICA
7 156							1						664 007 279	HEBEL, BESCHLEUNIGER		LEVER, THROTTLE	LEVIER	PALANCA, ACELERADOR
7 157							1						664 007 080	MOTORFERNBEDIENUNG (SATZ)		CABLE, TROTTLE	CABLE, ACCELERATEUR	CABLE, ACELERADOR
7 158							1						664 815 000	SCHRAUBE		SCREW	VIS	TORNILLO
7 159							1						664 356 703	SCHILD	(B&S)	LABEL	ETIQUETTE	ETIQUETA
7 231							1						664 140 223	MULCHEINSATZ	ACC.	MULCH PLUG	INSERT MULCH	TAPA
7 232							1						664 060 198	SCHUTZ		PROTECTION	PROTECTION	PROTECCIÓN
7 233							2						664 728 530	SCHRAUBE		SCREW	VIS	TORNILLO
7 251							2						664 293 200	MUTTER		NUT	ECROU	TUERCA
7 252							2						664 583 500	FEDERRING		GROWER	GROWER	ARANDELA DE PRESIÓN

Seite / Page	Pos.	EM-3310	EM-3713	EM-4316 S	EM-4816	PM-43	PM-48	PM-48 S	PM-480 S	PM-4850	PM-4850 S	PM-5150 S	Teil-Nr. Part No. No. de pièce No. de pieza	Bezeichnung	Spezifikation Specification	Description	Désignation	Denominación
7	253							2					664 523 070	SCHEIBE		WASHER	RONDELLE	ARANDELA
7	254							2					664 735 547	SEKTOR, HÖHENVERSTELLUNG		SECTOR, HEIGHT ADJUSTMENT	SECTEUR REGLAGE HAUTEUR	SECTOR, AJUSTE ALTURA
7	255							2					664 005 082	RADHALTER		SUPPORT, WHEEL	SUPPORT ROUE	SOPORTE, RUEDA
7	256							2					664 003 285	HEBEL, HÖHENVERSTELLUNG		LEVER, HEIGHT ADJUSTMENT	LEVIER, REGLAGE HAUTEUR	PALANCA, AJUSTE ALTURA
7	257							2					664 171 001	DISTANZRING		SPACER	ENTRETOISE	DISTANCIADOR
7	258							2					664 793 701	SCHRAUBE		SCREW	VIS	TORNILLO
7	258A							2					664 521 350	SCHEIBE		WASHER	RONDELLE	ARANDELA
7	259							8					664 122 200	KUGELLAGER		BEARING	COUSSINET	RODAMIENTO
7	260							2					664 007 336	RAD MIT STOLLENPROFIL	Ø 170	WHEEL, KNOBBLY	ROUE SCULPTEE	RUEDA CON PERFIL
7	261							2					664 521 350	SCHEIBE		WASHER	RONDELLE	ARANDELA
7	262							4					664 155 000	MÜTTER		NUT	ECROU	TUERCA
7	263							2					664 110 304	RADKAPPE ROT		HUB CAP RED	COUVRE-MOYEU ROUGE	TAPACUBOS ROJO
7	264							1					664 003 279	RASTHEBEL		LEVER, HEIGHT ADJUSTMENT	LEVIER, REGLAGE HAUTEUR	PALANCA, AJUSTE ALTURA
7	265							2					664 789 000	SCHRAUBE		SCREW	VIS	TORNILLO
7	266							2					664 154 330	MÜTTER		NUT	ECROU	TUERCA
7	267							2					664 007 337	RAD MIT STOLLENPROFIL	Ø 210	WHEEL, KNOBBLY	ROUE SCULPTEE	RUEDA CON PERFIL
7	268							2					664 110 305	RADKAPPE ROT		HUB CAP RED	COUVRE-MOYEU ROUGE	TAPACUBOS ROJO
7	269							2					664 369 500	FEDERSCHEIBE		ELASTIC WASHER	DISQUE ELASTIQUE	ARANDELA ELÁSTICA
7	270							2					664 530 150	FEDERSCHEIBE		ELASTIC WASHER	RONDELLE ELASTIQUE	ARANDELA ELÁSTICA
7	401							2					664 120 105	ZAHNRAD		RING GEAR	COURONNE	CORONA DENTADA
7	402							1					664 600 093	SCHUTZ, LINKS RÄDER		PROTECTION, L WHEEL	PROTECTION ROUE G	PROTECCION, RUEDA IZQ.
7	403							4					664 608 600	SICHERUNGSRING		SEEGER	SEEGER	ANILLO DE SEGURIDAD
7	404							1					664 570 120	RITZEL LINKS		PINION L	PIGNON G	PIÑÓN, IZQ.
7	405							2					664 216 035	LAGER		BEARING	COUSSINET	RODAMIENTO
7	406							1					664 600 092	SCHUTZ, RECHTS, RÄDER		PROTECTION, R WHEEL	PROTECTION ROUE D	PROTECCION, RUEDA DER.
7	407							1					664 000 147	ACHSE, HINTERRAD		AXLE, REAR WHEELS	AXE ROUES ARRIERE	EJE, RUEDAS TRASERAS
7	408							1					664 570 110	RITZEL RECHTS		PINION RIGHT	PIGNON D	PIÑÓN, DER.
7	410							1					664 000 672	KABEL, ANTRIEB	(BI. CI. DI.)	CABLE, REAR DRIVE	CÂBLE, COMMANDE TRACTION	CABLE, UNIDAD TRASERA
7	410							1					664 000 668	KABEL, ANTRIEB	(FRANCE REDUCTEURS)	CABLE, REAR DRIVE	CÂBLE, COMMANDE TRACTION	CABLE, UNIDAD TRASERA
7	411							1					664 003 081	ANTRIEB (GRAU)	(BI. CI. DI.)	GEAR BOX (GREY)	GROUPE TRACTION	UNIDAD DE TRACCIÓN (GRIS)
7	411							1					664 003 076	ANTRIEB	(FRANCE REDUCTEURS)	GEAR BOX	GROUPE TRACTION	UNIDAD DE TRACCIÓN
7	412							1					664 601 904	RIEMENSCHLEIBE		PULLEY	POULIE	POLEA
7	413							1					664 645 705	STIFT		PIN	GOUPILLE	PASADOR
7	414							1					664 033 280	VERSTELLHEBEL	(BI. CI. DI.)	ADJUSTMENT ROD	TIGE REGLAGE	VÁSTAGO DE AJUSTE
7	414							1					664 033 283	VERSTELLHEBEL	(FRANCE REDUCTEURS)	ADJUSTMENT ROD	TIGE REGLAGE	VÁSTAGO DE AJUSTE
7	415							1					664 063 800	KEILRIEMEN	Z 27	BELT	COURROIE	CORREA
7	416							2					664 753 000	STIFT		PIN	GOUPILLE	PASADOR
7	417							1					664 041 957	BUCHSE		BUSH	DOUILLE	CASQUILLO
7	418							1					664 450 063	FEDER		SPRING	RESSORT	RESORTE
7	419							1					664 680 009	SCHEIBE		WASHER	RONDELLE	ARANDELA
7	420							1					664 154 510	MÜTTER		NUT	ECROU	TUERCA
7	421							1					664 110 230	GUMMISTOPFEN		CAP	BOUCHON	TAPÓN
7	501							1					664 465 607	MESSERKUPPLUNG		HUB WITH PULLEY	MOYEU AVEC POULIE	SOPORTE DE LA CUCHILLA CON POLEA
7	502							1					664 531 048	MESSER	48 CM	BLADE	LAME	CUCHILLA ESTÁNDAR
7	503							1					664 160 400	TELLERFEDER		ELASTIC WASHER	RONDELLE ELASTIQUE	ARANDELA ELÁSTICA
7	504							1					664 523 080	SCHEIBE		WASHER	RONDELLE	ARANDELA
7	505							1					664 735 698	SCHRAUBE		SCREW	VIS	TORNILLO
7	506							1					664 139 100	SCHEIBENFEDER		FEATHER	CLAVETTE	CHAVETA
7	601							1					664 486 101	KORB, OBERTEIL		GRASS-BOX, UPPER	SAC, PARTIE	CESTO, SUPERIOR
7	602							1					664 608 525	VERSTÄRKUNG		STIFFENING LOWER	RÉNFORCEMENT INF	REFUERZO INFERIOR

Seite / Page	Pos.	EM-3310	EM-3713	EM-4316 S	EM-4816	PM-43	PM-48	PM-48 S	PM-480 S	PM-4850	PM-4850 S	PM-5150 S	Teil-Nr. Part No. No. de pièce No. de pieza	Bezeichnung	Spezifikation Specification	Description	Désignation	Denominación
7	603							1					664 002 211	SACK, TUCH		BOX, FABRIC	SAC, TOILE	GESTO, TELA
7	604							2					664 728 680	SCHRAUBE		SCREW	VIS	TORNILLO
7	605							2					664 523 050	SCHEIBE		WASHER	RONDELLE	ARANDELA

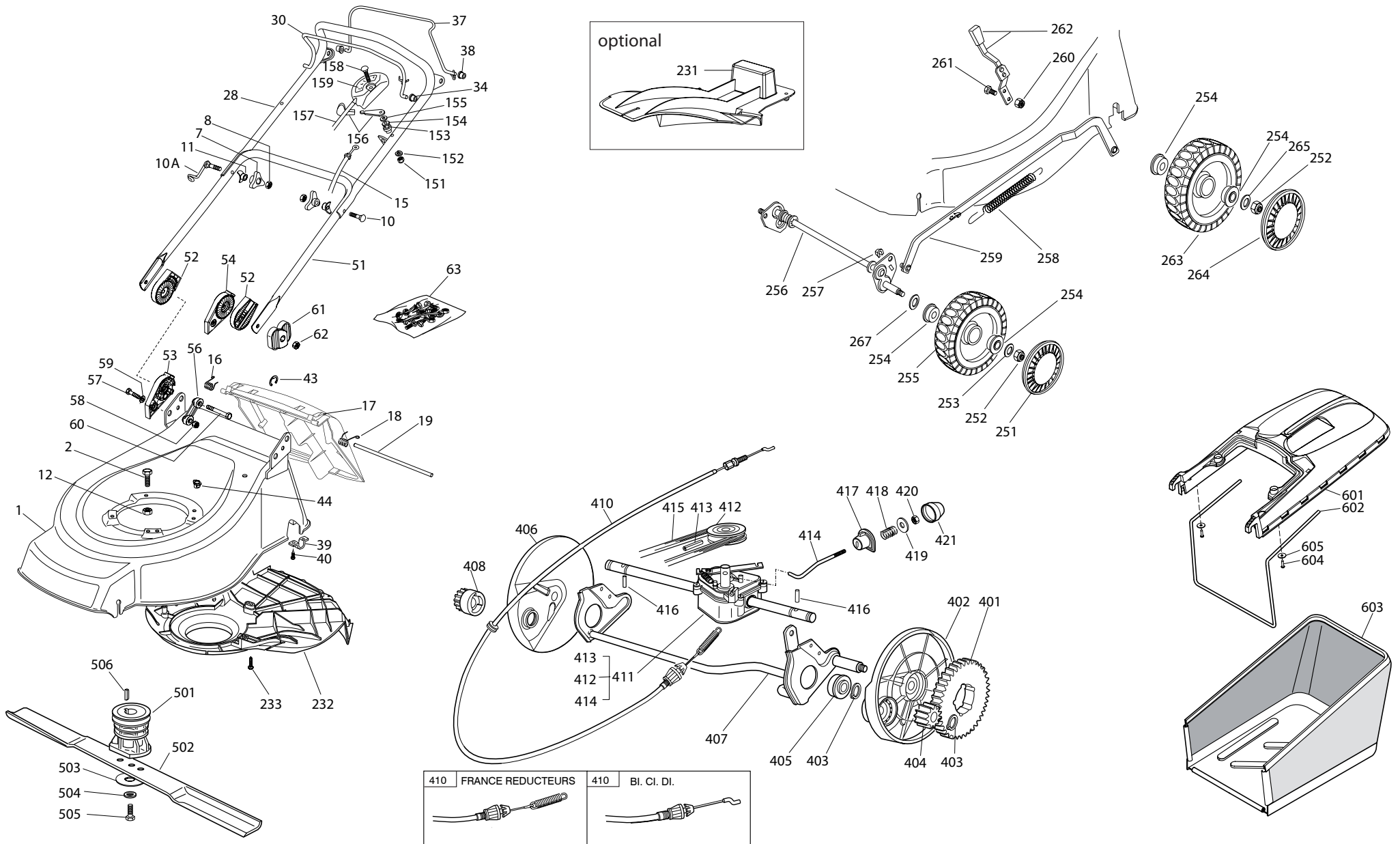

Seite / Page	Pos.	EM-3310	EM-3713	EM-4316 S	EM-4816	PM-43	PM-48	PM-48 S	PM-480 S	PM-4850	PM-4850 S	PM-5150 S	Teil-Nr. Part No. No. de pièce No. de pieza	Bezeichnung	Spezifikation Specification	Description	Désignation	Denominación
8	1								1				664 002 941	GEHAUSE ROT		DECK RED	CHASSIS ROUGE	CAJA ROJA
8	2								0/1				664 691 800	SCHRAUBE		SCREW	VIS	TORNILLO
8	2								3/2				664 793 701	SCHRAUBE		SCREW	VIS	TORNILLO
8	7								2				664 399 900	GRIFF		KNOB	POIGNÉE	MANETA
8	8								2				664 293 200	MUTTER		NUT	ECROU	TUERCA
8	10								1				664 819 201	SCHRAUBE		SCREW	VIS	TORNILLO
8	10A								1				664 003 801	HOLMFEDER		SPRING	RESSORT	RESORTE
8	11								2				664 680 006	SCHEIBE		WASHER	RONDELLE	ARANDELA
8	12								0/1				664 155 000	MUTTER		NUT	ECROU	TUERCA
8	12								3/2				664 293 201	MUTTER		NUT	ECROU	TUERCA
8	15								1				664 000 631	BOWDENZUG (MOTORBREMSE)	(B&S)	CABLE, THREAD MOTOR BRAKE	CABLE FREIN MOTEUR	CABLE DE BOWDEN, FRENO MOTOR
8	16								1				664 450 410	FEDER RECHTS		RIGHT SPRING	RESSORT D	RESORTE DER.
8	17								1				664 600 063	PRALLBLECH		STONE-GUARD	PARE-PIERRES	CUBIERTA PROTECTORA
8	18								1				664 450 420	FEDER LINKS		LEFT SPRING	RESSORT G	RESORTE IZQ.
8	19								1				664 517 906	STANGE		PIN	PIVOT	PASADOR
8	28								1				664 007 024	OBERTHOLM		HANDLE, UPPER PART	MANCHERON, PARTIE SUPERIEURE	MANILLAR, PARTE SUPERIOR
8	30								1				664 003 291	TOTMANN-BÜGEL		LEVER, MOTOR BRAKE	LEVIER FREIN MOTEUR	PALANCA, FRENO MOTOR
8	34								2				664 041 966	BUCHSE		BUSH	DOUILLE	CASQUILLO
8	37								1				664 003 288	HEBEL, ANTRIEB		LEVER, DRIVING	LEVIER TRACTION	PALANCA, CONDUCCIÓN
8	38								2				664 041 965	BUCHSE		BUSH	DOUILLE	CASQUILLO
8	39								2				664 545 152	LAGERSCHALE		PLATE	PLAQUETTE	COJINETE
8	40								4				664 731 350	SCHRAUBE		SCREW	VIS	TORNILLO
8	43								1				664 000 930	SPRENGRING		SNAP RING	ANNEAU RESSORT	ANILLO DE SUJECIÓN
8	44								1				664 291 150	GUMMIEINSATZ		RUBBER INSERT	INSERT DE	INSERTO DE CAUCHO
8	51								1				664 006 532	HOLM, UNTERTEIL		HANDLE, LOWER PART	MANCHERON, PARTIE INFERIEURE	MANILLAR, PARTE INFERIOR
8	52								2				664 785 081	HALTER, AUßEN		SUPPORT, EXTERNAL	SUPPORT EXTERNE	SOPORTE, EXTERIOR
8	53								1				664 785 082	HALTER, INNEN R		SUPPORT, R INTERNAL	SUPPORT INTERNE D	SOPORTE INTERIOR, DER.
8	54								1				664 785 083	HALTER, INNEN L		SUPPORT, L INTERNAL	SUPPORT INTERNE G	SOPORTE INTERIOR, IZQ.
8	56								2				664 551 575	PLATTE, INNEN		PLATE, INSIDE	PLAQUETTE INTERNE	PLANCHA, INTERIOR
8	57								2				664 793 701	SCHRAUBE		SCREW	VIS	TORNILLO
8	58								2				664 155 000	MUTTER		NUT	ECROU	TUERCA
8	59								2				664 521 350	SCHEIBE		WASHER	RONDELLE	ARANDELA
8	60								2				664 691 810	SCHRAUBE		SCREW	VIS	TORNILLO
8	61								2				664 399 803	GRIFF		KNOB	POIGNÉE	MANETA
8	62								2				664 293 202	MUTTER		NUT	ECROU	TUERCA
8	63								1				664 008 623	SATZ, SCHRAUBEN		OUTFIT, SCREWS	DOTATION VISSERIE	JUEGO DE TORNILLOS
8	151								1				664 291 000	MUTTER		NUT	ECROU	TUERCA
8	152								1				664 581 500	FEDERRING		GROWER	GROWER	ARANDELA DE PRESIÓN
8	153								1				664 171 005	DISTANZRING		SPACER	ENTRETOISE	DISTANCIADOR
8	154								1				664 521 360	SCHEIBE		WASHER	RONDELLE	ARANDELA
8	155								1				664 508 100	FEDERSCHEIBE		SPRING WASHER	RONDELLE ELASTIQUE	ARANDELA ELÁSTICA
8	156								1				664 007 279	HEBEL, BESCHLEUNIGER		LEVER, THROTTLE	LEVIER	PALANCA, ACELERADOR
8	157								1				664 007 080	MOTORFERNBEDIENUNG (SATZ)		CABLE, TROTTLE	CABLE, ACCELERATEUR	CABLE, ACELERADOR
8	158								1				664 815 000	SCHRAUBE		SCREW	VIS	TORNILLO
8	159								1				664 356 703	SCHILD	(B&S)	LABEL	ETIQUETTE	ETIQUETA
8	231								1				664 140 223	MULCHEINSATZ	optional for MULCHING	MULCH PLUG	INSERT MULCH	TAPA
8	232								1				664 060 198	SCHUTZ		PROTECTION	PROTECTION	PROTECCIÓN
8	233								2				664 728 530	SCHRAUBE		SCREW	VIS	TORNILLO
8	251								2				664 110 304	RADKAPPE ROT		HUB CAP RED	COUVRE-MOYEU ROUGE	TAPACUBOS ROJO
8	252								4				664 155 000	MUTTER		NUT	ECROU	TUERCA

Seite / Page	Pos.	EM-3310	EM-3713	EM-4316 S	EM-4816	PM-43	PM-48	PM-48 S	PM-480 S	PM-4850	PM-4850 S	PM-5150 S	Teil-Nr. Part No. No. de pièce No. de pieza	Bezeichnung	Spezifikation Specification	Description	Désignation	Denominación
8	253							2					664 521 350	SCHEIBE		WASHER	RONDELLE	ARANDELA
8	254							8					664 122 200	KUGELLAGER		BEARING	COUSSINET	RODAMIENTO
8	255							2					664 007 336	RAD MIT STOLLENPROFIL	D=170	WHEEL, KNOBBLY	ROUE SCULPTEE	RUEDA CON PERFIL
8	256							1					664 001 274	ACHSE, VORDERRAD		AXLE, FRONT WHEELS	AXE ROUES AVANT	EJE, RUEDAS DELANTERAS
8	257							2					664 436 050	PLATTCHEN		PLATE	PLAQUETTE	PLANCHA
8	258							1					664 446 180	FEDER		SPRING	RESSORT	RESORTE
8	259							1					664 001 276	STANGE,HOHENVERSTELLUNG		ROD, HEIGHT ADJUSTMENT	TIGE COMMANDE REGLAGE HAUTEUR	VASTAGO, AJUSTE ALTURA
8	260							2					664 154 330	MUTTER		NUT	ECROU	TUERCA
8	261							2					664 789 000	SCHRAUBE		SCREW	VIS	TORNILLO
8	262							1					664 003 279	RASTHEBEL		LEVER,HEIGHT ADJUSTMENT	LEVIER, REGLAGE HAUTEUR	PALANCA, AJUSTE ALTURA
8	263							2					664 007 337	RAD MIT STOLLENPROFIL	D=210	WHEEL, KNOBBLY	ROUE SCULPTEE	RUEDA CON PERFIL
8	264							2					664 110 305	RADKAPPE ROT		HUB CAP RED	COUVRE-MOYEU ROUGE	TAPACUBOS ROJO
8	265							2					664 369 500	FEDERSCHEIBE		ELASTIC WASHER	DISQUE ELASTIQUE	ARANDELA ELÁSTICA
8	267							2					664 530 150	FEDERSCHEIBE		ELASTIC WASHER	RONDELLE ELASTIQUE	ARANDELA ELÁSTICA
8	401							2					664 120 105	ZAHNRAD		RING GEAR	COURONNE	CORONA DENTADA
8	402							1					664 600 093	SCHUTZ, LINKS RÄDER		PROTECTION, LEFT WHEEL	PROTECTION ROUE G	PROTECCIÓN, RUEDA IZQ.
8	403							4					664 608 600	SICHERUNGSRING		SEEGER	SEEGER	ANILLO DE SEGURIDAD
8	404							1					664 570 120	RITZEL LINKS		PINION L	PIGNON G	PINÓN, IZQ.
8	405							2					664 216 035	LAGER		BEARING	COUSSINET	RODAMIENTO
8	406							1					664 600 092	SCHUTZ, RECHTS, RÄDER		PROTECTION, R WHEEL	PROTECTION ROUE D	PROTECCIÓN, RUEDA DER.
8	407							1					664 000 147	ACHSE, HINTERRAD		AXLE, REAR WHEELS	AXE ROUES ARRIERE	EJE, RUEDAS TRASERAS
8	408							1					664 570 110	RITZEL RECHTS		PINION RIGHT	PIGNON D	PINÓN, DER.
8	410							1					664 000 672	KABEL ANTRIEB	(BI. CI. DI.)	CABLE, REAR DRIVE	CÂBLE, COMMANDE TRACTION	CABLE, UNIDAD TRASERA
8	410							1					664 000 668	KABEL ANTRIEB	(FRANCE REDUCTEURS)	CABLE, REAR DRIVE	CÂBLE, COMMANDE TRACTION	CABLE, UNIDAD TRASERA
8	411							1					664 003 081	ANTRIEB (GRAU)	(BI. CI. DI.)	GEAR BOX (GREY)	GROUPE TRACTION (GRIS)	UNIDAD DE TRACCIÓN (GRIS)
8	411							1					664 003 076	ANTRIEB	(FRANCE REDUCTEURS)	GEAR BOX	GROUPE TRACTION	UNIDAD DE TRACCIÓN
8	412							1					664 601 904	RIEMENSCHLEIBE		PULLEY	POULIE	POLEA
8	413							1					664 645 705	STIFT		PIN	GOUPILLE	PASADOR
8	414							1					664 033 280	VERSTELLHEBEL	(BI. CI. DI.)	ADJUSTMENT ROD	TIGE REGLAGE	VASTAGO DE AJUSTE
8	414							1					664 033 283	VERSTELLHEBEL	(FRANCE REDUCTEURS)	ADJUSTMENT ROD	TIGE REGLAGE	VASTAGO DE AJUSTE
8	415							1					664 063 800	KEILRIEMEN		BELT	COURROIE	CORREA
8	416							2					664 753 000	STIFT		PIN	GOUPILLE	PASADOR
8	417							1					664 041 957	BÜCHSE		BUSH	DOUILLE	CASQUILLO
8	418							1					664 450 063	FEDER		SPRING	RESSORT	RESORTE
8	419							1					664 680 009	SCHEIBE		WASHER	RONDELLE	ARANDELA
8	420							1					664 154 510	MUTTER		NUT	ECROU	TUERCA
8	421							1					664 110 230	GUMMISTOPFEN		CAP	BOUCHON	TAPÓN
8	501							1					664 465 607	MESSERKUPPLUNG		HUB WITH PULLEY	MOYEU AVEC POULIE	SOPORTE DE LA CUCHILLA CON POLEA
8	502							1					664 531 048	MESSER	48CM	BLADE	LAME	CUCHILLA ESTÁNDAR
8	503							1					664 160 400	TELLERFEDER		ELASTIC WASHER	RONDELLE ELASTIQUE	ARANDELA ELÁSTICA
8	504							1					664 523 080	SCHEIBE		WASHER	RONDELLE	ARANDELA
8	505							1					664 735 698	SCHRAUBE		SCREW	VIS	TORNILLO
8	506							1					664 139 100	SCHEIBENFEDER		FEATHER	CLAVETTE	CHAVETA
8	601							1					664 486 101	KORB OBERTEIL		GRASS-BOX, UPPER	SAC, PARTIE	CESTO, SUPERIOR
8	602							1					664 608 525	VERSTÄRKUNG		STIFFENING LOWER	RÉNFORCEMENT INF	REFUERZO INFERIOR
8	603							1					664 002 211	SACK, TUCH		BOX, FABRIC	SAC, TOILE	CESTO, TELA
8	604							2					664 728 680	SCHRAUBE		SCREW	VIS	TORNILLO
8	605							2					664 523 050	SCHEIBE		WASHER	RONDELLE	ARANDELA

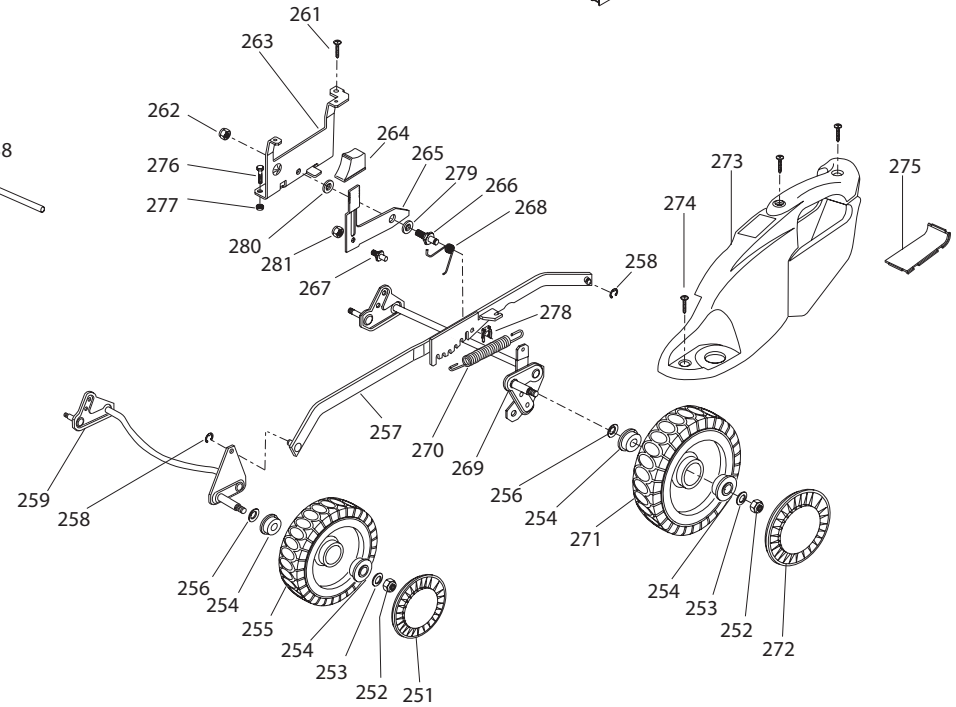
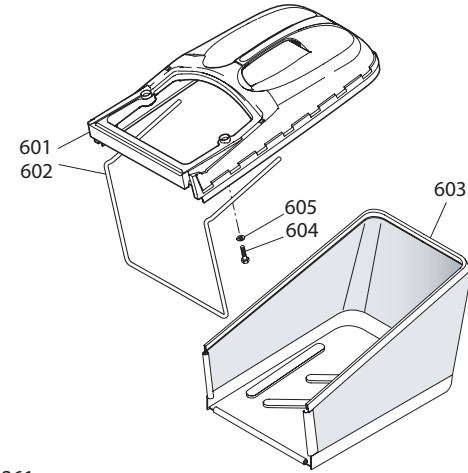
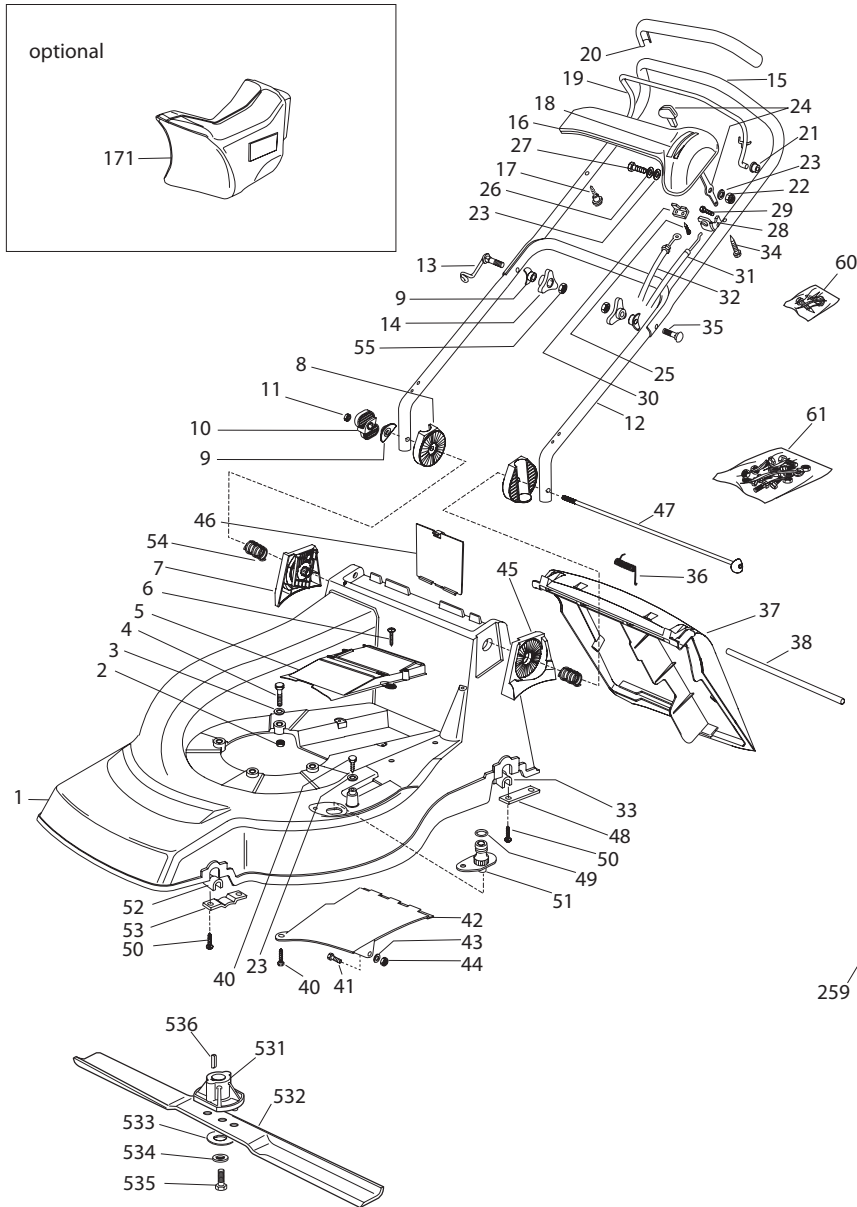
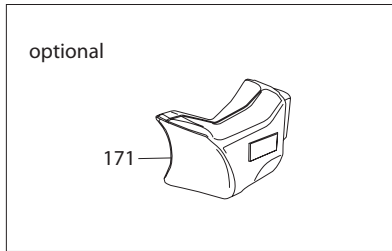

Seite / Page	Pos.	EM-3310	EM-3713	EM-4316 S	EM-4816	PM-43	PM-48	PM-48 S	PM-480 S	PM-4850	PM-4850 S	PM-5150 S	Teil-Nr. Part No. No. de pièce No. de pieza	Bezeichnung	Spezifikation Specification	Description	Désignation	Denominación
9 1													664 002 731	GEHAUSE ROT		DECK RED	CHASSIS ROUGE	CAJA ROJA
9 2													664 155 000	MUTTER		NUT	ECROU	TUERCA
9 3													664 521 350	SCHEIBE		WASHER	RONDELLE	ARANDELA
9 4													664 691 800	SCHRAUBE		SCREW	VIS	TORNILLO
9 5													664 060 200	SCHUTZ, RIEMEN		PROTECTION, BELT	PROTECTION	PROTECCIÓN, CORREA
9 6													664 728 522	SCHRAUBE		SCREW	VIS	TORNILLO
9 7													664 785 077	HALTER INNEN R		SUPPORT, R INTERNAL	SUPPORT INTERNE D	SOPORTE INTERIOR, DER.
9 8													664 785 076	HALTER AUßEN		SUPPORT, EXTERNAL	SUPPORT EXTERNE	SOPORTE, EXTERIOR
9 9													664 680 006	SCHEIBE		WASHER	RONDELLE	ARANDELA
9 10													664 399 803	GRIFF		KNOB	POIGNÉE	MANETA
9 11													664 293 202	MUTTER		NUT	ECROU	TUERCA
9 12													664 007 033	HOLM, UNTERTEIL		HANDLE, LOWER PART	MANCHERON, PARTIE INFERIEURE	MANILLAR, PARTE INFERIOR
9 13													664 003 801	HOLMFEDER		SPRING	RESSORT	RESORTE
9 14													664 399 900	GRIFF		KNOB	POIGNÉE	MANETA
9 15													664 007 018	OBERHOLM		HANDLE, UPPER PART	MANCHERON, PARTIE SUPERIEURE	MANILLAR, PARTE SUPERIOR
9 16													664 120 158	KONSOLE SCHWARZ		DASH BOARD BLACK	CONSOLE NOIRE	CONSOLA NEGRA
9 17													664 943 006	SCHRAUBE		SCREW	VIS	TORNILLO
9 18													664 356 744	SCHILD	(B&S)	LABEL	ETIQUETTE	ETIQUETA
9 19													664 003 291	HEBEL, MOTORBREMSE		LEVER, MOTOR BRAKE	LEVIER FREIN MOTEUR	PALANCA, FRENO MOTOR
9 20													664 291 050	HANDGRIFF SCHWARZ		HANDGRIP BLACK	POIGNÉE NOIRE	EMPUÑADURA NEGRA
9 21													664 041 966	BUCHSE		BUSH	DOUILLE	CASQUILLO
9 22													664 154 510	MUTTER		NUT	ECROU	TUERCA
9 23													664 523 040	SCHEIBE		WASHER	RONDELLE	ARANDELA
9 24													664 007 280	HEBEL BESCHLEUNIGER		LEVER, THROTTLE	LEVIER	PALANCA, ACELERADOR
9 25													664 735 105	SCHRAUBE		SCREW	VIS	TORNILLO
9 26													664 530 060	FEDERSCHEIBE		ELASTIC WASHER	RONDELLE ELASTIQUE	ARANDELA ELÁSTICA
9 27													664 791 500	SCHRAUBE		SCREW	VIS	TORNILLO
9 28													664 806 612	HALTER		SUPPORT	SUPPORT	SOPORTE
9 29													664 728 518	SCHRAUBE		SCREW	VIS	TORNILLO
9 30													664 981 467	PLATTE		PLATE	PLAQUETTE	PLANCHA
9 31													664 007 160	BOWDENZUG (FERNBEDIENUNG)		BOWDEN CABLE	CABLE, ACCELERATEUR	CABLE DE BOWDEN, ACELERADOR
9 32													664 000 631	BOWDENZUG (MOTORBREMSE)	(B&S)	CABLE, THREAD MOTOR BRAKE	CABLE FREIN MOTEUR	CABLE DE BOWDEN, FRENO MOTOR
9 33													664 038 399	BUCHSE		BUSH	DOUILLE	CASQUILLO
9 34													664 728 460	SCHRAUBE		SCREW	VIS	TORNILLO
9 35													664 819 201	SCHRAUBE		SCREW	VIS	TORNILLO
9 36													664 451 000	FEDER		SPRING	RESSORT	RESORTE
9 37													664 600 066	PRALLBLECH		STONE-GUARD	PARE-PIERRES	CUBIERTA PROTECTORA
9 38													664 517 857	BOLZEN		PIN	PIVOT	PIVOTE
9 40													664 729 600	SCHRAUBE		SCREW	VIS	TORNILLO
9 41													664 789 000	SCHRAUBE		SCREW	VIS	TORNILLO
9 42													664 108 205	ABDECKBLECH		PLATE	CONVOYEUR	PLANCHA PROTECTORA
9 43													664 523 020	SCHEIBE		WASHER	RONDELLE	ARANDELA
9 44													664 154 330	MUTTER		NUT	ECROU	TUERCA
9 45													664 785 078	HALTER INNEN L		SUPPORT, L INTERNAL	SUPPORT INTERNE G	SOPORTE INTERIOR, IZQ.
9 46													664 595 352	ABDECKPLATTE		INSPECTION DOOR	VOYANT DE VISITE	PUERTA DE INSPECCIÓN
9 47													664 001 208	BOLZEN		PIN	PIVOT	PIVOTE
9 48													664 545 142	PLATTE		PLATE	PLAQUETTE	PLANCHA
9 49													664 035 000	RING OR		OR RING	BAGUE OR	ARANDELA OR
9 50													664 731 350	SCHRAUBE		SCREW	VIS	TORNILLO
9 51													664 034 000	SCHLAUCHANSCHLUSS		WASHING CONNECTION	ATTAQUE LAVAGE	RACOR DE EMPALME

Seite / Page	Pos.	EM-3310	EM-3713	EM-4316 S	EM-4816	PM-43	PM-48	PM-48 S	PM-480 S	PM-4850	PM-4850 S	PM-5150 S	Teil-Nr. Part No. No. de pièce No. de pieza	Bezeichnung	Spezifikation Specification	Description	Désignation	Denominación
9	52												664 038 400	BUCHSE		BUSH	DOUILLE	CASQUILLO
9	53												664 545 156	PLATTE		PLATE	PLAQUETTE	PLANCHA
9	54												664 446 190	FEDER		SPRING	RESSORT	RESORTE
9	55												664 293 200	MUTTER		NUT	ECROU	TUERCA
9	59												664 008 609	SATZ KONSOLE SCHRAUBEN		OUTFIT, DASH-BOARD SCREWS	DOTATION VISSERIE CONSOLLE	TORNILLOS PARA CONSOLA
9	60												664 008 623	SATZ, SCHRAUBEN		OUTFIT, SCREWS	DOTATION VISSERIE	JUEGO DE TORNILLOS
9	171												664 140 224	MULCHEINSATZ	ACC.	MULCH PLUG	INSERT MULCH	TAPA
9	251												664 110 304	RADKAPPE ROT		HUB CAP RED	COUVRE-MOYEU ROUGE	TAPACUBOS ROJO
9	252												664 155 000	MUTTER		NUT	ECROU	TUERCA
9	253												664 521 350	SCHEIBE		WASHER	RONDELLE	ARANDELA
9	254												664 122 200	KUGELLAGER		BEARING	COUSSINET	RODAMIENTO
9	255												664 007 317	RAD	Ø 170	WHEEL	ROUE	RUEDA
9	256												664 530 150	FEDERSCHEIBE		ELASTIC WASHER	RONDELLE ELASTIQUE	ARANDELA ELÁSTICA
9	257												664 001 135	STANGE,HÖHENVERSTELLUNG		ROD, HEIGHT ADJUSTMENT	TIGE COMMANDE REGLAGE HAUTEUR	VÁSTAGO, AJUSTE ALTURA
9	258												664 000 930	SPRENGRING		SNAP RING	ANNEAU RESSORT	ANILLO DE SUJECIÓN
9	259												664 002 801	ACHSE, VORDERRAD		AXLE, FRONT WHEELS	AXE ROUES AVANT	EJE, RUEDAS DELANTERAS
9	261												664 729 600	SCHRAUBE		SCREW	VIS	TORNILLO
9	262												664 155 000	MUTTER		NUT	ECROU	TUERCA
9	263												664 785 115	HALTER		SUPPORT, HEIGHT	SUPPORT REGLAGE	SOPORTE, ALTURA
9	264												664 602 000	STEUERHEBEL,DRUCK		PUSHBUTTON, LEVER	BOUTON DE	PULSADOR, PALANCA
9	265												664 322 829	HEBEL HOHENVERSTELLUNG		LEVER, HEIGHT ADJUSTMENT	LEVIER, REGLAGE HAUTEUR	PALANCA, AJUSTE ALTURA
9	266												664 517 880	BOLZEN		PIN	PIVOT	PIVOTE
9	267												664 519 746	BOLZEN		PIN	PIVOT	PIVOTE
9	268												664 446 176	FEDER		SPRING	RESSORT	RESORTE
9	269												664 002 804	ACHSE HINTERRAD		AXLE, REAR WHEELS	AXE ROUES ARRIERE	EJE, RUEDAS TRASERAS
9	270												664 446 180	FEDER		SPRING	RESSORT	RESORTE
9	271												664 007 318	RAD	Ø 170	WHEEL	ROUE	RUEDA
9	272												664 110 305	RADKAPPE ROT		HUB CAP RED	COUVRE-MOYEU ROUGE	TAPACUBOS ROJO
9	273												664 060 146	GEHÄUSE		DECK, ADJUSTMENT	CHÂSSIS REGLAGE	CARCASA, AJUSTE
9	274												664 728 520	SCHRAUBE		SCREW	VIS	TORNILLO
9	275												664 546 070	PLATTE		PLATE	PLAQUETTE	PLANCHA
9	276												664 793 101	SCHRAUBE		SCREW	VIS	TORNILLO
9	277												664 293 201	MUTTER		NUT	ECROU	TUERCA
9	278												664 436 050	PLATTCHEN		PLATE	PLAQUETTE	PLANCHA
9	279												664 672 152	SCHEIBE		WASHER	RONDELLE	ARANDELA
9	280												664 672 151	SCHEIBE		WASHER	RONDELLE	ARANDELA
9	281												664 154 510	MUTTER		NUT	ECROU	TUERCA
9	531												664 463 012	MESSERKUPPLUNG		HUB WITH PULLEY	MOYEU AVEC POULIE	SOPORTE DE LA CUCHILLA
9	532												664 004 366	MESSER		BLADE	LAME	CUCHILLA ESTÁNDAR
9	533												664 160 400	TELLERFEDER		ELASTIC WASHER	RONDELLE ELASTIQUE	ARANDELA ELÁSTICA
9	534												664 523 080	SCHEIBE		WASHER	RONDELLE	ARANDELA
9	535												664 735 698	SCHRAUBE		SCREW	VIS	TORNILLO
9	536												664 139 100	SCHEIBENFEDER		FEATHER	CLAVETTE	CHAVETA
9	601												664 486 102	KORB, OBERTEIL		GRASS-BOX, UPPER	SAC, PARTIE	CESTO, SUPERIOR
9	602												664 608 526	VERSTÄRKUNG		STIFFENING LOWER	RÉNFORCEMENT INF	REFUERZO INFERIOR
9	603												664 002 212	SACK, TUCH		BOX, FABRIC	SAC, TOILE	CESTO, TELA
9	604												664 728 680	SCHRAUBE		SCREW	VIS	TORNILLO
9	605												664 523 050	SCHEIBE		WASHER	RONDELLE	ARANDELA

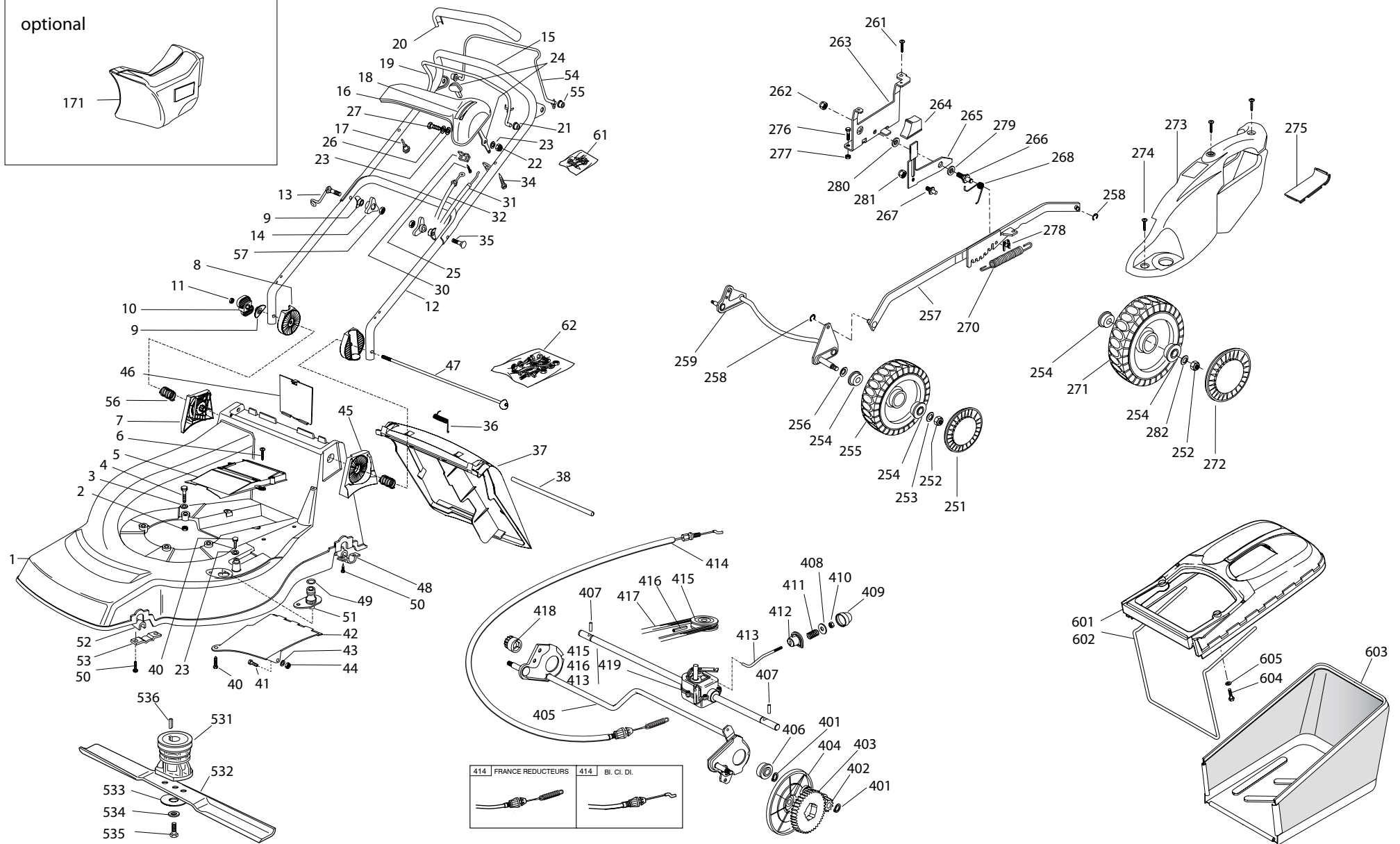
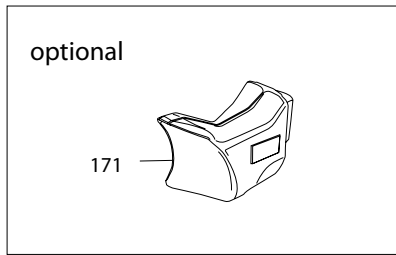



Seite / Page	Pos.	EM-3310	EM-3713	EM-4316 S	EM-4816	PM-43	PM-48	PM-48 S	PM-480 S	PM-4850	PM-4850 S	PM-5150 S	Teil-Nr. Part No. No. de pièce No. de pieza	Bezeichnung	Spezifikation Specification	Description	Désignation	Denominación
10	1												664 002 731	GEHAUSE ROT		DECK RED	CHASSIS ROUGE	CAJA ROJA
10	2												664 155 000	MUTTER		NUT	ECROU	TUERCA
10	3												664 521 350	SCHEIBE		WASHER	RONDELLE	ARANDELA
10	4												664 691 800	SCHRAUBE		SCREW	VIS	TORNILLO
10	5												664 060 200	SCHUTZ, RIEMEN		PROTECTION, BELT	PROTECTION	PROTECCIÓN, CORREA
10	6												664 728 522	SCHRAUBE		SCREW	VIS	TORNILLO
10	7												664 785 077	HALTER, INNEN R		SUPPORT, R INTERNAL	SUPPORT INTERNE D	SOPORTE INTERIOR, DER.
10	8												664 785 076	HALTER, AUßEN		SUPPORT, EXTERNAL	SUPPORT EXTERNE	SOPORTE, EXTERIOR
10	9												664 680 006	SCHEIBE		WASHER	RONDELLE	ARANDELA
10	10												664 399 803	GRIFF		KNOB	POIGNÉE	MANETA
10	11												664 293 202	MUTTER		NUT	ECROU	TUERCA
10	12												664 007 033	HOLM, UNTERTEIL		HANDLE, LOWER PART	MANCHERON, PARTIE INFERIEURE	MANILLAR, PARTE INFERIOR
10	13												664 003 801	FEDER		SPRING	RESSORT	RESORTE
10	14												664 399 900	GRIFF		KNOB	POIGNÉE	MANETA
10	15												664 007 024	OBERHOLM		HANDLE, UPPER PART	MANCHERON, PARTIE SUPERIEURE	MANILLAR, PARTE SUPERIOR
10	16												664 120 158	KONSOLE SCHWARZ		DASH BOARD BLACK	CONSOLE NOIRE	CONSOLA NEGRA
10	17												664 943 006	SCHRAUBE		SCREW	VIS	TORNILLO
10	18												664 356 744	SCHILD	(B&S)	LABEL	ETIQUETTE	ETIQUETA
10	19												664 003 291	HEBEL, MOTORBREMSE		LEVER, MOTOR BRAKE	LEVIER FREIN MOTEUR	PALANCA, FRENO MOTOR
10	20												664 291 050	HANDGRIFF SCHWARZ		HANDGRIP BLACK	POIGNÉE NOIRE	EMPUÑADURA NEGRA
10	21												664 041 966	BUCHSE		BUSH	DOUILLE	CASQUILLO
10	22												664 154 510	MUTTER		NUT	ECROU	TUERCA
10	23												664 523 040	SCHEIBE		WASHER	RONDELLE	ARANDELA
10	24												664 007 280	HEBEL, BESCHLEUNIGER		LEVER, THROTTLE	LEVIER	PALANCA, ACELERADOR
10	25												664 735 105	SCHRAUBE		SCREW	VIS	TORNILLO
10	26												664 530 060	FEDERSCHEIBE		ELASTIC WASHER	RONDELLE ELASTIQUE	ARANDELA ELÁSTICA
10	27												664 791 500	SCHRAUBE		SCREW	VIS	TORNILLO
10	30												664 981 467	PLATTE		PLATE	PLAQUETTE	PLANCHA
10	31												664 007 160	BOWDENZUG (FERNBEDIENUNG)		CABLE, TROTTLE	CABLE, ACCELERATEUR	CABLE DE BOWDEN, ACELERADOR
10	32												664 000 631	BOWDENZUG (MOTORBREMSE)	(B&S)	CABLE, THREAD MOTOR BRAKE	CABLE FREIN MOTEUR	CABLE DE BOWDEN, FRENO MOTOR
10	34												664 728 460	SCHRAUBE		SCREW	VIS	TORNILLO
10	35												664 819 201	SCHRAUBE		SCREW	VIS	TORNILLO
10	36												664 451 000	FEDER		SPRING	RESSORT	RESORTE
10	37												664 600 066	PRALLBLECH		STONE-GUARD	PARE-PIERRES	CUBIERTA PROTECTORA
10	38												664 517 857	BOLZEN		PIN	PIVOT	PIVOTE
10	40												664 729 600	SCHRAUBE		SCREW	VIS	TORNILLO
10	41												664 789 000	SCHRAUBE		SCREW	VIS	TORNILLO
10	42												664 108 205	ABDECKBLECH		PLATE	CONVOYEUR	PLANCHA PROTECTORA
10	43												664 523 020	SCHEIBE		WASHER	RONDELLE	ARANDELA
10	44												664 154 330	MUTTER		NUT	ECROU	TUERCA
10	45												664 785 078	HALTER, INNEN L		SUPPORT, L INTERNAL	SUPPORT INTERNE G	SOPORTE INTERIOR, IZQ.
10	46												664 595 352	ABDECKPLATTE		INSPECTION DOOR	VOYANT DE VISITE	PUERTA DE INSPECCIÓN
10	47												664 001 208	BOLZEN		PIN	PIVOT	PIVOTE
10	48												664 545 152	LAGERSCHALE		PLATE	PLAQUETTE	COJINETE
10	49												664 035 000	RING OR		OR RING	BAGUE OR	ARANDELA OR
10	50												664 731 350	SCHRAUBE		SCREW	VIS	TORNILLO
10	51												664 034 000	SCHLAUCHANSCHLUSS		WASHING CONNECTION	ATTAQUE LAVAGE	RACOR DE EMPALME
10	52												664 038 400	BUCHSE		BUSH	DOUILLE	CASQUILLO
10	53												664 545 156	PLATTE		PLATE	PLAQUETTE	PLANCHA
10	54												664 003 288	HEBEL, ANTRIEB		LEVER, DRIVING	LEVIER TRACTION	PALANCA, CONDUCCIÓN

Seite / Page	Pos.	EM-3310	EM-3713	EM-4316 S	EM-4816	PM-43	PM-48	PM-48 S	PM-480 S	PM-4850	PM-4850 S	PM-5150 S	Teil-Nr. Part No. No. de pièce No. de pieza	Bezeichnung	Spezifikation Specification	Description	Désignation	Denominación
10	55												664 041 965	BUCHSE		BUSH	DOUILLE	CASQUILLO
10	56												664 446 190	FEDER		SPRING	RESSORT	RESORTE
10	57												664 293 200	MUTTER		NUT	ECROU	TUERCA
10	61												664 008 609	SATZ, KONSOLE SCHRAUBEN		OUTFIT, DASH-BOARD SCREWS	DOTATION VISSERIE CONSOLLE	JUEGO DE TORNILLOS PARA LA CONSOLA
10	62												664 008 623	SATZ, SCHRAUBEN		OUTFIT, SCREWS	DOTATION VISSERIE	JUEGO DE TORNILLOS
10	171												664 140 224	MULCHEINSATZ	ACC.	MULCH PLUG	INSERT MULCH	TAPA
10	251												664 110 304	RADKAPPE ROT		HUB CAP RED	COUVRE-MOYEU ROUGE	TAPACUBOS ROJO
10	252												664 155 000	MUTTER		NUT	ECROU	TUERCA
10	253												664 521 350	SCHEIBE		WASHER	RONDELLE	ARANDELA
10	254												664 122 200	KUGELLAGER		BEARING	COUSSINET	RODAMIENTO
10	255												664 007 317	RAD	Ø 170	WHEEL	ROUE	RUEDA
10	256												664 530 150	FEDERSCHEIBE		ELASTIC WASHER	RONDELLE ELASTIQUE	ARANDELA ELÁSTICA
10	257												664 001 135	STANGE, HOHENVERSTELLUNG		ROD, HEIGHT ADJUSTMENT	TIGE COMMANDE REGLAGE HAUTEUR	VÁSTAGO, AJUSTE ALTURA
10	258												664 000 930	SPRENGRING		SNAP RING	ANNEAU RESSORT	ANILLO DE SUJECIÓN
10	259												664 002 801	ACHSE, VORDERRAD		AXLE, FRONT WHEELS	AXE ROUES AVANT	EJE, RUEDAS DELANTERAS
10	261												664 729 600	SCHRAUBE		SCREW	VIS	TORNILLO
10	262												664 155 000	MUTTER		NUT	ECROU	TUERCA
10	263												664 785 115	HALTER,		SUPPORT, HEIGHT	SUPPORT REGLAGE	SOPORTE, ALTURA
10	264												664 602 000	STEUERHEBEL, DRUCK		PUSHBUTTON, LEVER	BOUTON DE	PULSADOR, PALANCA
10	265												664 322 829	HEBEL, HOHENVERSTELLUNG		LEVER, HEIGHT ADJUSTMENT	LEVIER, REGLAGE HAUTEUR	PALANCA, AJUSTE ALTURA
10	266												664 517 880	BOLZEN		PIN	PIVOT	PIVOTE
10	267												664 519 746	BOLZEN		PIN	PIVOT	PIVOTE
10	268												664 446 176	FEDER		SPRING	RESSORT	RESORTE
10	270												664 446 180	FEDER		SPRING	RESSORT	RESORTE
10	271												664 007 318	RAD	Ø 170	WHEEL	ROUE	RUEDA
10	272												664 110 305	RADKAPPE ROT		HUB CAP RED	COUVRE-MOYEU ROUGE	TAPACUBOS ROJO
10	273												664 060 146	GEHAUSE		DECK, ADJUSTMENT	CHÂSSIS REGLAGE	CARCASA, AJUSTE
10	274												664 728 520	SCHRAUBE		SCREW	VIS	TORNILLO
10	275												664 546 070	PLATTE		PLATE	PLAQUETTE	PLANCHA
10	276												664 793 101	SCHRAUBE		SCREW	VIS	TORNILLO
10	277												664 293 201	MUTTER		NUT	ECROU	TUERCA
10	278												664 436 050	PLÄTTCHEN		PLATE	PLAQUETTE	PLANCHA
10	279												664 672 152	SCHEIBE		WASHER	RONDELLE	ARANDELA
10	280												664 672 151	SCHEIBE		WASHER	RONDELLE	ARANDELA
10	281												664 154 510	MUTTER		NUT	ECROU	TUERCA
10	282												664 369 500	FEDERSCHEIBE		ELASTIC WASHER	DISQUE ELASTIQUE	ARANDELA ELÁSTICA
10	401												664 608 600	SICHERUNGSRING		SEEGER	SEEGER	ANILLO DE SEGURIDAD
10	402												664 570 120	RITZEL LINKS		PINION L	PIGNON G	PIÑÓN, IZQ.
10	403												664 120 105	ZAHNRAD		RING GEAR	COURONNE	CORONA DENTADA
10	404												664 600 091	SCHUTZ, RÄDER		PROTECTION, WHEEL	PROTECTION ROUE	PROTECCIÓN, RUEDA
10	405												664 002 811	ACHSE, HINTERRAD		AXLE, REAR WHEELS	AXE ROUES ARRIERE	EJE, RUEDAS TRASERAS
10	406												664 216 035	LAGER		BEARING	COUSSINET	RODAMIENTO
10	407												664 753 000	STIFT		PIN	GOUPILLE	PASADOR
10	408												664 680 009	SCHEIBE		WASHER	RONDELLE	ARANDELA
10	409												664 110 230	GUMMISTOPFEN		CAP	BOUCHON	TAPÓN
10	410												664 154 510	MUTTER		NUT	ECROU	TUERCA
10	411												664 450 063	FEDER		SPRING	RESSORT	RESORTE
10	412												664 041 957	BUCHSE		BUSH	DOUILLE	CASQUILLO
10	413												664 033 281	VERSTELLSTANGE		ADJUSTMENT ROD	TIGE REGLAGE	VÁSTAGO DE AJUSTE
10	414												664 000 673	KABEL, ANTRIEB	(Bl. Cl. Di.)	CABLE, REAR DRIVE	CÂBLE, COMMANDE TRACTION	CABLE, UNIDAD TRASERA

Seite / Page	Pos.	EM-3310	EM-3713	EM-4316 S	EM-4816	PM-43	PM-48	PM-48 S	PM-480 S	PM-4850	PM-4850 S	PM-5150 S	Teil-Nr. Part No. No. de pièce No. de pieza	Bezeichnung	Spezifikation Specification	Description	Désignation	Denominación
10 414											1		664 000 669	KABEL, ANTRIEB	(FRANCE REDUCTEURS)	CABLE, REAR DRIVE	CABLE, COMMANDE TRACTION	CABLE, UNIDAD TRASERA
10 415											1		664 601 909	RIEMENSCHLEIBE		PULLEY	POULIE	POLEA
10 416											1		664 645 705	STIFT		PIN	GOUPILLE	PASADOR
10 417											1		664 064 150	KEILRIEMEN	Z 32	BELT	COURROIE	CORREA
10 418											1		664 570 110	RITZEL RECHTS		PINION RIGHT	PIGNON D	PINON, DER.
10 419											1		664 003 082	ANTRIEB (GRAU)	(Bl. Cl. Dl.)	GEAR BOX (GREY)	GROUPE TRACTION (GRIS)	UNIDAD DE TRACCIÓN (GRIS)
10 419											1		664 003 079	ANTRIEB	(FRANCE REDUCTEURS)	GEAR BOX	GROUPE TRACTION	UNIDAD DE TRACCIÓN
10 531											1		664 465 607	MESSERKUPPLUNG		HUB WITH PULLEY	MOYEU AVEC POULIE	SOPORTE DE LA CUCHILLA CON POLEA
10 532											1		664 004 366	MESSER	48 CM	BLADE	LAME	CUCHILLA ESTÁNDAR
10 533											1		664 160 400	TELLERFEDER		ELASTIC WASHER	RONDELLE ELASTIQUE	ARANDELA ELÁSTICA
10 534											1		664 523 080	SCHEIBE		WASHER	RONDELLE	ARANDELA
10 535											1		664 735 698	SCHRAUBE		SCREW	VIS	TORNILLO
10 536											1		664 139 100	SCHEIBENFEDER		FEATHER	CLAVETTE	CHAVETA
10 601											1		664 486 102	KORB, OBERTEIL		GRASS-BOX, UPPER	SAC, PARTIE	CESTO, SUPERIOR
10 602											1		664 608 526	VERSTÄRKUNG		STIFFENING LOWER	RÉNFORCEMENT INF	REFUERZO INFERIOR
10 603											1		664 002 212	SACK, TUCH		BOX, FABRIC	SAC, TOILE	CESTO, TELA
10 604											2		664 728 680	SCHRAUBE		SCREW	VIS	TORNILLO
10 605											2		664 523 050	SCHEIBE		WASHER	RONDELLE	ARANDELA

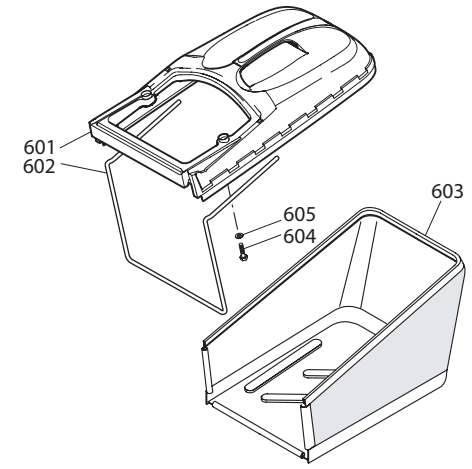
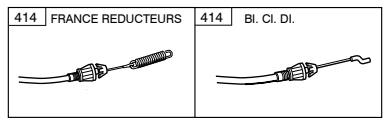
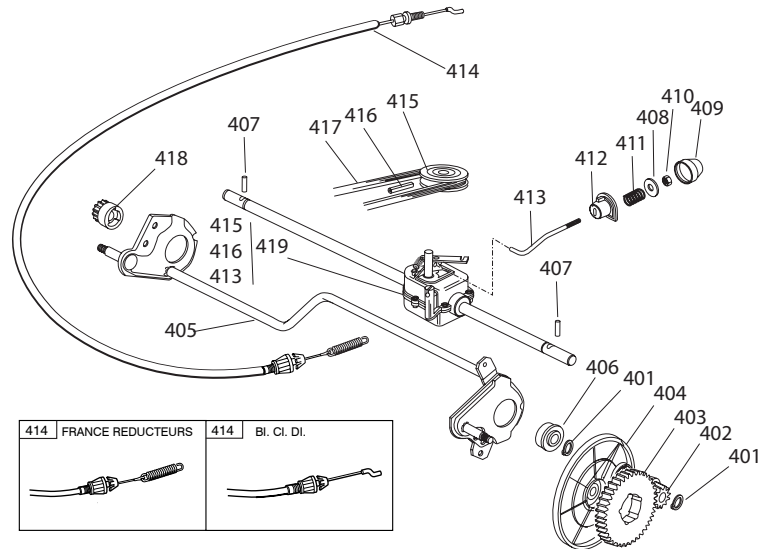
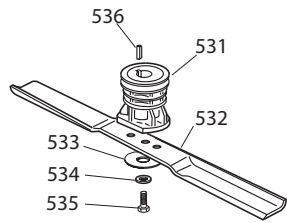
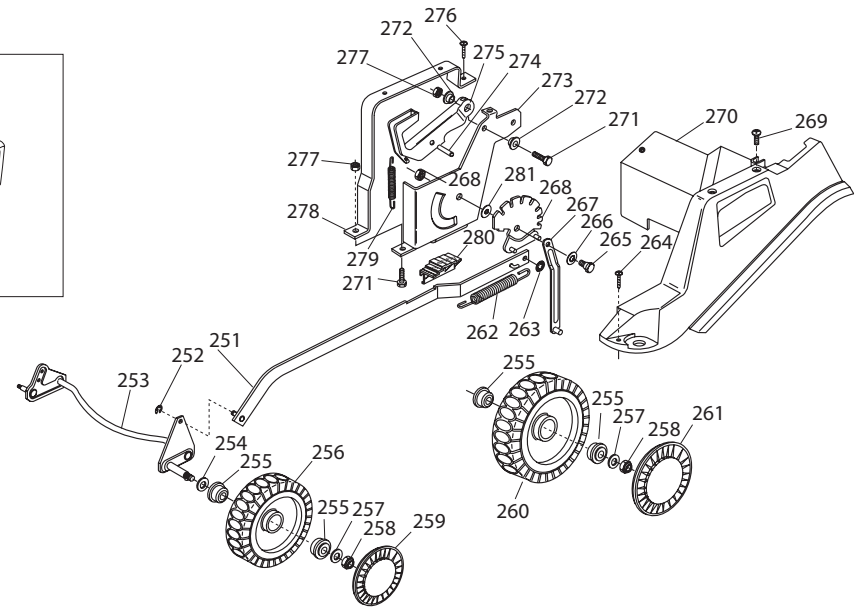
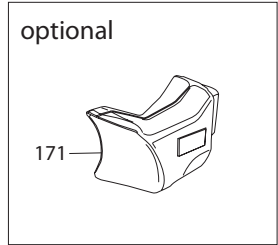
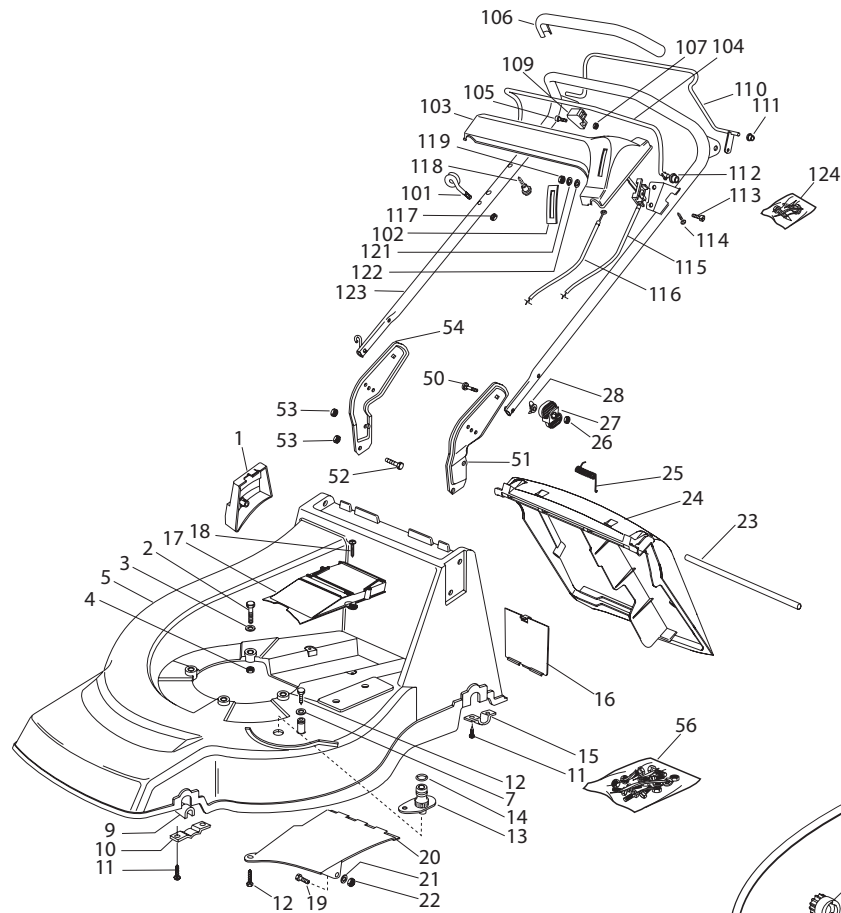

Seite / Page	Pos.	EM-3310	EM-3713	EM-4316 S	EM-4816	PM-43	PM-48	PM-48 S	PM-4850	PM-5150 S	Teil-Nr. Part No. No. de pièce No. de pieza	Bezeichnung	Spezifikation Specification	Description	Désignation	Denominación
11	1									1	664 601 001	SCHUTZ		PROTECTION	PROTECTION	PROTECCIÓN
11	2									3/2	664 691 800	SCHRAUBE	M8X60	SCREW	VIS	TORNILLO
11	2									0/1	664 692 080	SCHRAUBE		SCREW	VIS	TORNILLO
11	3									3	664 521 350	SCHEIBE		WASHER	RONDELLE	ARANDELA
11	4									3	664 155 000	MUTTER		NUT	ECROU	TUERCA
11	5									1	664 002 732	GEHÄUSE ROT		DECK RED	CHÂSSIS ROUGE	CAJA ROJA
11	7									1	664 523 040	SCHEIBE		WASHER	RONDELLE	ARANDELA
11	9									2	664 038 400	BUCHSE		BUSH	DOUILLE	CASQUILLO
11	10									2	664 545 156	PLATTE		PLATE	PLAQUETTE	PLANCHA
11	11									8	664 731 350	SCHRAUBE		SCREW	VIS	TORNILLO
11	12									2	664 729 600	SCHRAUBE		SCREW	VIS	TORNILLO
11	13									1	664 034 000	SCHLAUCHANSCHLUß		WASHING CONNECTION	ATTAQUE LAVAGE	RACOR DE EMPALME
11	14									1	664 035 000	RING OR		OR RING	BAGUE OR	ARANDELA OR
11	15									2	664 545 152	LAGERSCHALE		PLATE	PLAQUETTE	COJINETE
11	16									1	664 595 352	ABDECKPLATTE		INSPECTION DOOR	VOYANT DE VISITE	PUERTA DE INSPECCIÓN
11	17									1	664 060 200	SCHUTZ,RIEMEN		PROTECTION, BELT	PROTECTION	PROTECCIÓN, CORREA
11	18									2	664 728 522	SCHRAUBE		SCREW	VIS	TORNILLO
11	19									1	664 789 000	SCHRAUBE		SCREW	VIS	TORNILLO
11	20									1	664 108 205	ABDECKBLECH		PLATE	CONVOYEUR	PLANCHA PROTECTORA
11	21									1	664 523 020	SCHEIBE		WASHER	RONDELLE	ARANDELA
11	22									1	664 154 330	MUTTER		NUT	ECROU	TUERCA
11	23									1	664 517 857	BOLZEN		PIN	PIVOT	PIVOTE
11	24									1	664 600 066	PRALLBLECH		STONE-GUARD	PARE-PIERRES	CUBIERTA PROTECTORA
11	25									1	664 451 000	FEDER		SPRING	RESSORT	RESORTE
11	26									2	664 293 200	6KT-MUTTER	M8	NUT	ECROU	TUERCA
11	27									2	664 399 803	GRIFF		KNOB	POIGNÉE	MANETA
11	28									2	664 680 006	SCHEIBE		WASHER	RONDELLE	ARANDELA
11	50									2	664 819 120	SCHRAUBE		SCREW	VIS	TORNILLO
11	51									1	664 778 397	HALTER FÜHRUNGSHOLM LINKS		BRACKET, L	BRIDE G	SOPORTE, IZQ.
11	52									2	664 793 301	SCHRAUBE		SCREW	VIS	TORNILLO
11	53									4	664 155 000	MUTTER		NUT	ECROU	TUERCA
11	54									1	664 778 396	HALTER FÜHRUNGSHOLM RECHTS		BRACKET, R	BRIDE D	SOPORTE, DER.
11	56									1	664 008 610	SATZ, SCHRAUBEN		OUTFIT, SCREWS	DOTATION VISSERIE	JUEGO DE TORNILLOS
11	101									1	664 430 309	FEDERFÜHRUNG		GUIDE SPRING	RESSORT DE GUIDE	RESORTE DE GUÍA
11	102									1	664 356 693	SCHILD	(B&S)	LABEL	ETIQUETTE	ETIQUETA
11	103									1	664 120 164	KONSOLE SCHWARZ		DASH BOARD BLACK	CONSOLE NOIRE	CONSOLA NEGRA
11	104									1	664 003 291	HEBEL, MOTORBREMSE		LEVER, MOTOR BRAKE	LEVIER FREIN MOTEUR	PALANCA, FRENO MOTOR
11	105									1	664 726 399	SCHRAUBE		SCREW	VIS	TORNILLO
11	106									1	664 291 050	HANDGRIFF SCHWARZ		HANDGRIP BLACK	POIGNÉE NOIRE	EMPUÑADURA NEGRA
11	107									2	664 290 800	MUTTER		NUT	ECROU	TUERCA
11	109									1	664 399 801	GRIFF		KNOB	POIGNÉE	MANETA
11	110									1	664 003 288	BÜGEL		LEVER,DRIVING	LEVIER TRACTION	PALANCA, CONDUCCIÓN
11	111									2	664 041 965	BUCHSE		BUSH	DOUILLE	CASQUILLO
11	112									2	664 041 966	BUCHSE		BUSH	DOUILLE	CASQUILLO
11	113									2	664 788 910	SCHRAUBE		SCREW	VIS	TORNILLO
11	114									2	664 728 460	SCHRAUBE		SCREW	VIS	TORNILLO
11	115									1	664 007 091	KABEL BESCHLEUNIGER	(B&S)	CABLE, TROTTLE	CABLE, ACCELERATEUR	CABLE, ACELERADOR
11	116									1	664 000 634	KABEL MOTORBREMSE	(B&S)	CABLE, THREAD MOTOR BRAKE	CABLE FREIN MOTEUR	CABLE, FRENO MOTOR
11	117									1	664 154 330	MUTTER		NUT	ECROU	TUERCA
11	118									1	664 943 006	SCHRAUBE		SCREW	VIS	TORNILLO

Seite / Page	Pos.	EM-3310	EM-3713	EM-4316 S	EM-4816	PM-43	PM-48	PM-48 S	PM-480 S	PM-4850	PM-5150 S	Teil-Nr. Part No. No. de pièce No. de pieza	Bezeichnung	Spezifikation Specification	Description	Désignation	Denominación	
11	119											2	664 291 000	MUTTER		NUT	ECROU	TUERCA
11	121											2	664 581 500	FEDERRING		GROWER	GROWER	ARANDELA DE PRESIÓN
11	122											2	664 523 020	SCHEIBE		WASHER	RONDELLE	ARANDELA
11	123											1	664 007 028	HOLM, OBERTEIL		HANDLE, UPPER PART	MANCHÉRON, PARTIE SUPERIEURE	MANILLAR, PARTE SUPERIOR
11	124											1	664 008 499	SATZ KONSOLE SCHRAUBEN		OUTFIT, DASH-BOARD SCREWS	DOTATION VISSERIE CONSOLLE	TORNILLOS PARA CONSOLA
11	171											1	664 140 224	MULCHEINSATZ	optional for MULCHING	MULCH PLUG	INSERT MULCH	TAPA
11	251											1	664 001 134	STANGE, HÖHENVERSTELLUNG		ROD, HEIGHT ADJUSTMENT	TIGE COMMANDE REGLAGE HAUTEUR	VÁSTAGO, AJUSTE ALTURA
11	252											2	664 000 930	SPRENGRING		SNAP RING	ANNEAU RESSORT	ANILLO DE SUJECIÓN
11	253											1	664 002 801	ACHSE VORDERRAD		AXLE, FRONT WHEELS	AXE ROUES AVANT	EJE, RUEDAS DELANTERAS
11	254											2	664 530 150	FEDERSCHEIBE		ELASTIC WASHER	RONDELLE ELASTIQUE	ARANDELA ELÁSTICA
11	255											8	664 122 200	KUGELLAGER		BEARING	COUSSINET	RODAMIENTO
11	256											2	664 007 317	RAD		WHEEL	ROUE	RUEDA
11	257											2	664 521 350	SCHEIBE		WASHER	RONDELLE	ARANDELA
11	258											4	664 155 000	MUTTER		NUT	ECROU	TUERCA
11	259											2	664 110 304	RADKAPPE VORN ROT		HUB CAP RED	COUVRE-MOYEU ROUGE	TAPACUBOS ROJO
11	260											2	664 007 318	RAD		WHEEL	ROUE	RUEDA
11	261											2	664 110 305	RADKAPPE HINTEN ROT		HUB CAP RED	COUVRE-MOYEU ROUGE	TAPACUBOS ROJO
11	262											1	664 446 180	FEDER		SPRING	RESSORT	RESORTE
11	263											2	664 604 899	SICHERUNGSSCHEIBE		SAFETY DISC	FIXATEUR A	ARANDELA DE SEGURIDAD
11	264											3	664 728 519	SCHRAUBE		SCREW	VIS	TORNILLO
11	265											1	664 529 662	BOLZEN		PIN	PIVOT	PIVOTE
11	266											1	664 672 151	SCHEIBE		WASHER	RONDELLE	ARANDELA
11	267											1	664 001 269	STANGE HINTERRADACHSE		ROD, REAR WHEELS AXLE	TIGE, AXE ROUE ARRIERES	VÁSTAGO, EJE RUEDAS TRASERAS
11	268											1	664 000 479	SEKTOR, HÖHENVERSTELLUNG		SECTOR, HEIGHT ADJUSTMENT	SECTEUR REGLAGE HAUTEUR	SECTOR, AJUSTE ALTURA
11	269											1	664 728 520	SCHRAUBE		SCREW	VIS	TORNILLO
11	270											1	664 060 144	GEHAUSE		DECK, ADJUSTMENT	CHÂSSIS REGLAGE	CARCASA, AJUSTE
11	271											3	664 793 301	SCHRAUBE		SCREW	VIS	TORNILLO
11	272											2	664 038 002	BUCHSE		BUSH	DOUILLE	CASQUILLO
11	273											1	664 785 109	HALTER		SUPPORT, HEIGHT	SUPPORT REGLAGE	SOPORTE, ALTURA
11	274											1	664 622 640	STIFT		PIN	GOUPILLE	PASADOR
11	275											1	664 393 611	GRIFF		KNOB	POIGNÉE	MANETA
11	276											1	664 729 600	SCHRAUBE		SCREW	VIS	TORNILLO
11	277											3	664 293 201	MUTTER		NUT	ECROU	TUERCA
11	278											1	664 785 113	HALTER GRIFF		SUPPORT, HANDLE	SUPPORT POIGNÉE	SOPORTE, MANILLAR
11	279											1	664 446 175	FEDER		SPRING	RESSORT	RESORTE
11	280											1	664 570 200	PLATTE HÖHENVERSTELLUNG		PLATE, CUTTING POSITIONS	PLAQUETTE REGLAGE	PLANCHA, POSICIONES DE CORTE
11	281											1	664 672 152	SCHEIBE		WASHER	RONDELLE	ARANDELA
11	401											4	664 608 600	SICHERUNGSRING		SEEGER	SEEGER	ANILLO DE SEGURIDAD
11	402											1	664 570 120	RITZEL LINKS		PINION LEFT	PIGNON G	PIÑÓN, IZQ.
11	403											2	664 120 105	ZAHNRAD		RING GEAR COURONNE	COURONNE	CORONA DENTADA
11	404											2	664 600 091	SCHÜTZ, RÄDER		PROTECTION, WHEEL	PROTECTION ROUE	PROTECCIÓN, RUEDA
11	405											1	664 002 811	ACHSE HINTERRAD		AXLE, REAR WHEELS	AXE ROUES ARRIERE	EJE, RUEDAS TRASERAS
11	406											2	664 216 035	LAGER		BEARING	COUSSINET	RODAMIENTO
11	407											2	664 753 000	STIFT		PIN	GOUPILLE	PASADOR
11	408											1	664 680 009	SCHEIBE		WASHER	RONDELLE	ARANDELA
11	409											1	664 110 230	GUMMISTOPFEN		CAP	BOUCHON	TAPÓN
11	410											1	664 154 510	MUTTER		NUT	ECROU	TUERCA
11	411											1	664 450 063	FEDER		SPRING	RESSORT	RESORTE
11	412											1	664 041 957	BUCHSE		BUSH	DOUILLE	CASQUILLO
11	413											1	664 033 281	VERSTELLSTANGE		ADJUSTMENT ROD	TIGE REGLAGE	VÁSTAGO DE AJUSTE

Seite / Page	Pos.	EM-3310	EM-3713	EM-4316 S	EM-4816	PM-43	PM-48	PM-48 S	PM-480 S	PM-4850	PM-4850 S	PM-5150 S	Teil-Nr. Part No. No. de pièce No. de pieza	Bezeichnung	Spezifikation Specification	Description	Désignation	Denominación
11	414											1	664 000 673	KABEL ANTRIEB	(BI. CI. DI.)	CABLE, REAR DRIVE	CABLE, COMMANDE TRACTION	CABLE, UNIDAD TRASERA
11	414											1	664 000 669	KABEL ANTRIEB	(FRANCE REDUCTEURS)	CABLE, REAR DRIVE	CÂBLE, COMMANDE TRACTION	CABLE, UNIDAD TRASERA
11	415											1	664 601 909	RIEMENSCHLEIBE		PULLEY	POULIE	POLEA
11	416											1	664 645 705	STIFT		PIN	GOUPILLE	PASADOR
11	417											1	664 064 195	KEILRIEMEN		BELT	COURROIE	CORREA
11	418											1	664 570 110	RITZEL RECHTS		PINION RIGHT	PIGNON D	PIÑÓN, DER.
11	419											1	664 003 082	ANTRIEB (GRAU)	(BI. CI. DI.)	GEAR BOX (GREY)	GROUPE TRACTION (GRIS)	UNIDAD DE TRACCIÓN (GRIS)
11	419											1	664 003 079	ANTRIEB	(FRANCE REDUCTEURS)	GEAR BOX	GROUPE TRACTION	UNIDAD DE TRACCIÓN
11	531											1	664 465 607	MESSERKUPPLUNG		HUB WITH PULLEY	MOYEU AVEC POULIE	SOPORTE DE LA CUCHILLA
11	532											1	664 004 381	MESSER		BLADE	LAME	CUCHILLA ESTÁNDAR
11	533											1	664 160 400	TELLERFEDER		SPRING WASHER	RONDELLE ELASTIQUE	ARANDELA ELÁSTICA
11	534											1	664 523 080	SCHEIBE		WASHER	RONDELLE	ARANDELA
11	535											1	664 735 698	SCHRAUBE		SCREW	VIS	TORNILLO
11	536											1	664 139 100	SCHEIBENFEDER		FEATHER	CLAVETTE	CHAVETA
11	601											1	664 486 102	KORB OBERTEIL		GRASS-BOX, UPPER	SAC, PARTIE	CESTO, SUPERIOR
11	602											1	664 608 526	VERSTÄRKUNG		STIFFENING LOWER	RÉNFORCEMENT INF	REFUERZO INFERIOR
11	603											1	664 002 212	SACK, TUCH		BOX, FABRIC	SAC, TOILE	CESTO, TELA
11	604											2	664 728 680	SCHRAUBE		SCREW	VIS	TORNILLO
11	605											2	664 523 050	SCHEIBE		WASHER	RONDELLE	ARANDELA

1	EM-3310
2	EM-3713
3	EM-4316 S
4	EM-4816
5	PM-43
6	PM-48
7	PM-48 S
8	PM-480 S
9	PM-4850
10	PM-4850 S
11	PM-5150 S

	Zeichenerklärung	Key to symbols	Légende	Explicación de símbolos
<p>⇒ 1999999 2000000 ⇒ 2003.04 ⇒ TI 2003/07 Acc. = { m Corr.</p>	<p>Produktion bis Serien-Nr. Neues Teil ab Serien-Nr. Neues Teil ab Jahr / Monat Siehe Technische Information Jahr / Nr. Zubehör (nicht im Lieferumfang) Keine Serienausführung, jedoch verwendbar Beinhaltet Positions-Nr. Meterware Druckfehlerberichtigung</p>	<p>Production to serial number New part from serial number New part from Year / Month See Technical Information Year / No. Accessories (not included in the delivery inventory) No standard execution, may be used Contains item number Sold by the meter Error correction</p>	<p>Production jusqu'à n° de série Nouveau pièce à partir du n° de série Nouveau pièce à partir de année / mois Voir information technique année / n° Accessoires (non compris dans la livraison) Aucune exécut. en série, cependant utilisable contient n° de numéro Au mètre Rectification d'erreurs</p>	<p>Producción hasta N° de serie Pieza nueva a partir de N° de serie Pieza nueva a partir de año / mes Véase inform. técnico año / N° Accesorios (no incluido en la extensión del suministro) No es de serie, pero sirve Contiene pos N° Por metro Fe de erratas</p>
	Änderungen vorbehalten	Specifications subject to change without notice	Changements sans préavis	Mejoras constructivas sin previo aviso