

Ersatzteilliste
Spare Parts List
Liste de pièces détachées
Lista de piezas de repuesto

2004-09

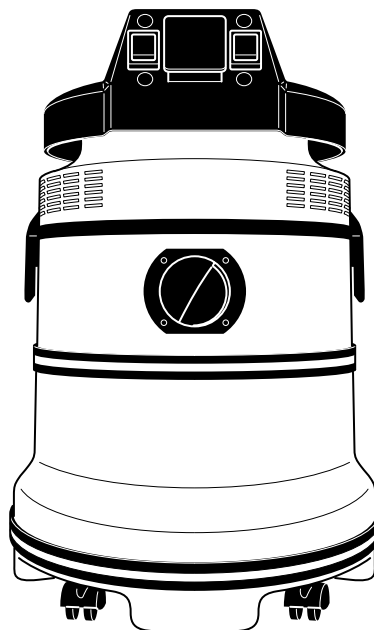

WD-2035

DOLMAR



A member of the *Makita* Group

995 700 189 (D, GB, F, E)

DOLMAR GmbH

Postfach 70 04 20

D-22004 Hamburg

Germany

WD-2035

1

Gehäuse, Motor
Case, motor
Carter, moteur
Carter, motor

DOLMAR
■■■■■■■■■■

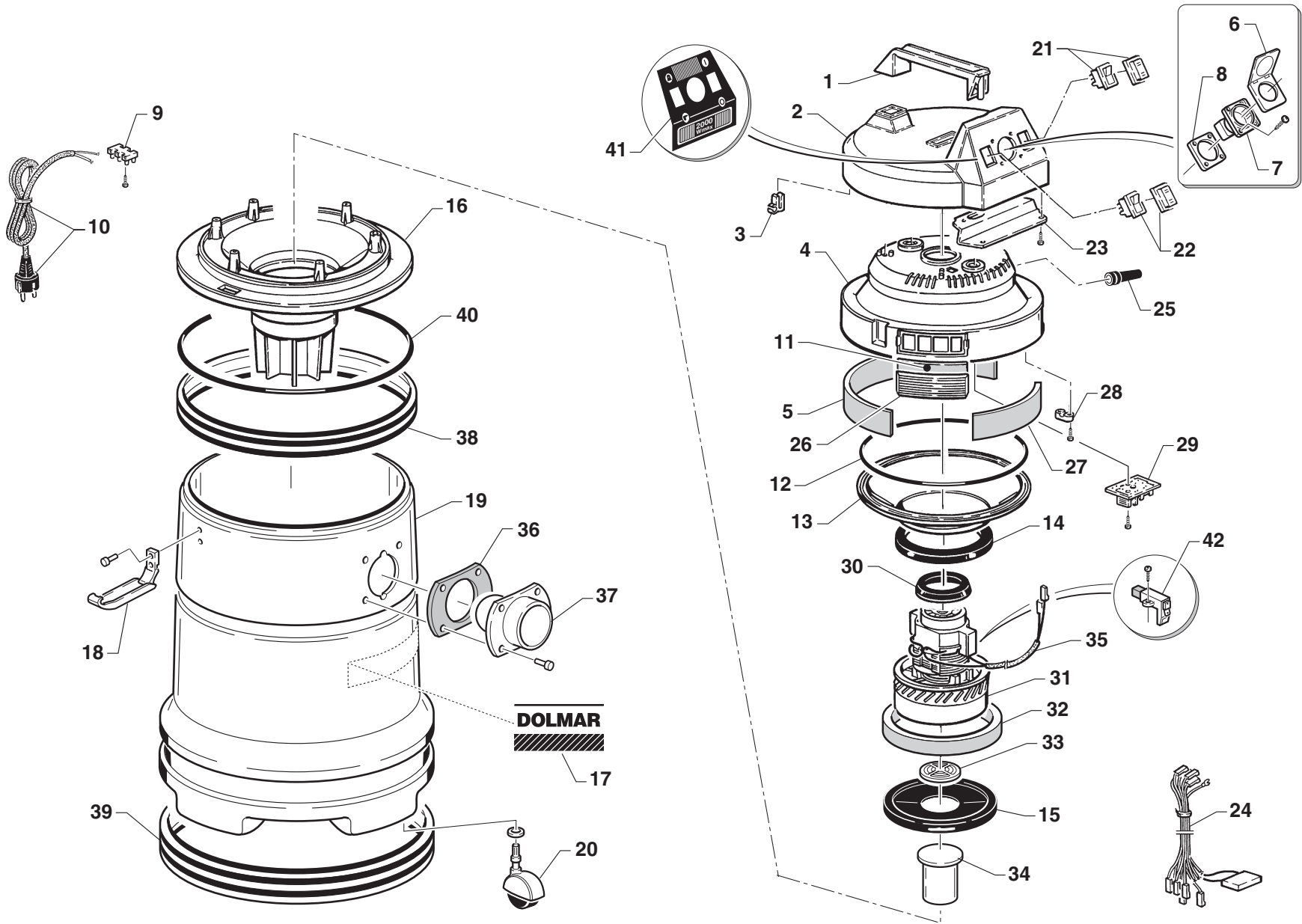

WD-2035

DOLMAR



Seite/Page	Pos.	WD-2035	Teil-Nr. Part No. No. de pièce No. de pieza	Hinweise Notes Renseign. Nota	Bezeichnung	Spezifikation Specification	Description	Désignation	Denominación
1	1	1	668 050 310		Griff		Handle	Poignée	Mango
1	2	1	668 050 305		Haube		Cap	Capot	Capota
1	3	1	668 050 335		Kabelklemme		Cable fastener	Borne de câble	Abrazadera para cables
1	4	1	668 050 181		Motorgehäuse		Motor cover	Carter-moteur	Carcasa del motor
1	5	1	668 083 022		Dämmung lang		Cap long silencer	Silencieux long	Silenciador largo
1	6	1	668 080 202		Abdeckung		Outer shell + cover	Couvercle	Cubierta
1	7	1	668 080 200		Anschlussdose		Schuko socket	Prise de connexion	Base de enchufe Schucko
1	8	1	668 050 315		Halter		Socket lock nut	Support	Soporte
1	9	1	668 080 029		Kabelklemme		Tripolar terminal	Borne de câble	Bornes de cable
1	10	1	668 080 017		Anschlussleitung		Feeder	Câble de connexion	Línea de conexión
1	11	1	668 083 021		Filtergitter		Filter grill	Grille de filtre	Rejilla del filtro
1	12	1	668 070 016		Dichtung		Round gasket	Joint	Junta
1	13	1	668 050 104		Einsatz		Diaphragm	Insert	Diafragma
1	14	1	668 070 055		Einsatzdichtung		Diaphragm seal	Joint d'insert	Junta del diafragma
1	15	1	668 070 032		Motordichtung unten		Lower motor seal	Joint moteur inférieur	Junta inferior del motor
1	16	1	668 050 179		Motorträger		Motor support	Support de moteur	Soporte del motor
1	17	1	668 085 636		Aufkleber		Container adhesive	Autocollant	Etiqueta adhesiva para la caja del motor
1	18	1	668 001 015		Klippverschluss		Complete hinge	Clip	Cierre de bisagra
1	19	1	668 060 027		Auffangbehälter		Container	Collecteur	Contenedor
1	20	1	668 030 086		Drehrolle		Rotating wheel	Roulette	Rodkillo de giro
1	21	1	668 080 041		Schalter		Black bipolar switch with red led	Interrupteur	interruptor
1	22	1	668 080 042		Schalter		Unipolar switch	Interrupteur	Interruptor unipolar
1	23	1	668 050 300		Abdeckung		Closing plate	Couvercle	Cubierta
1	24	1	668 080 100		Kabelsatz		Set of wires	Jeu de câbles	Juego de cables
1	25	1	668 050 338		Knickschutz		Cable guide	Guide-câble	Protección contra dobladura
1	26	1	668 050 170		Auslassgitter		Outlet air grill	Grille d'évacuation	Rejilla de salida
1	27	1	668 083 023		Dämmung kurz		Cap short silencer	Silencieux court	Silenciador corto
1	28	1	668 050 333		Halter		Fastener	Support	Sujeción
1	29	1	668 080 209		Platine		Integrated electronic card	Circuit imprimé	Tarjeta electrónica
1	30	1	668 070 060		Dämpfer		Upper motor absorber	Amortisseur	Amortiguador
1	31	1	668 020 036		Motor	1000W	Motor	Moteur	Motor
1	32	1	668 083 020		Dämmring		Silencer ring	Bague d'insonorisation	Anillo silenciador
1	33	1	668 050 183		Schutzgitter		Protection grill	Grille de protection	Rejilla de protección
1	34	1	668 050 077		Schwimmer		Float	Floteur	Flotador
1	35	1	668 060 235		Schrumpfschlauch	ø 6mm x 110mm	Black plastic tube	Tube flexible thermorétractable	Tubo termorretractil
1	36	1	668 070 082		Dichtung		Expanded polyethylene gasket	Joint	Junta
1	37	1	668 050 079		Schlauchanschluss		Air inlet connection	Raccord de tuyau	Conexión de tubo flexible
1	38	1	668 060 029		Stoßschutz oben	96cm	Upper band shock-proof for container	Protège-choc supérieur	Banda de prot. contra golpes, superior
1	39	1	668 060 030		Stoßschutz unten	112cm	Lower band shock-proof for container	Protège-choc intérieur	Banda de prot. contra golpes, interior
1	40	1	668 070 011		Dichtung		Semi-round sponge rubber	Joint	Junta
1	41	1	668 085 036		Haubenaufkleber		Cap adhesive	Autocollant de capot	Etiqueta adhesiva para la tapa
1	42	1	668 080 051		Kohlebürsten		Brush insert	Balais de charbon	Escobilla de carbón

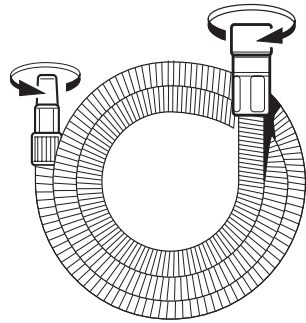

A01

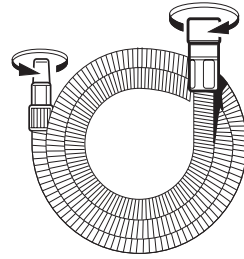

A02

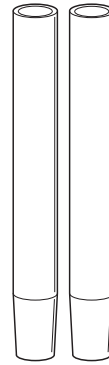

A03



A04

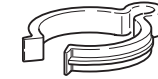

A05

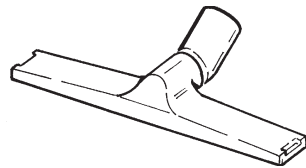

A06

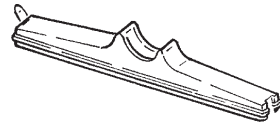

A07

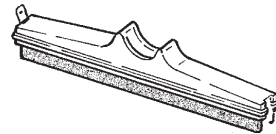

A08



A09

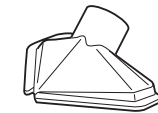

A10



A11

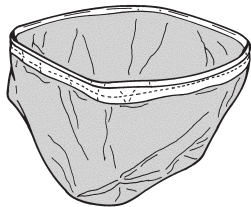

A12

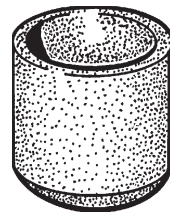

A13

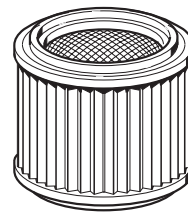

A14

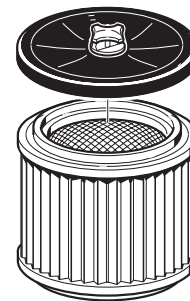

A15



A16

WD-2035

DOLMAR



Seite/Page	Pos.	WD-2035	Teil-Nr. Part No. No. de pièce No. de pieza	Hinweise Notes Renseign. Nota	Bezeichnung	Spezifikation Specification	Description	Désignation	Denominación
2	A01	1	668 001 316		Flex. Schlauch	ø 45mm x 2m	Flex. tube with sleeves	Tuyau flexible	Tubo flexible
2	A02	1	668 001 321		Flex. Schlauch für E-Werkzeug	ø 25mm x 3m	Flex. tube for electric tools w. sleeves	Tuyau flexible pour outil électrique	Tubo flexible para herramienta eléctrica
2	A03	1	668 050 091		Verlängerung	ø 45mm	Rigid extention	Rallonge	Prolongación
2	A04	1	668 050 095		Einstellring		Outflow ring	Anneau de réglage	Anillo de flujo
2	A05	1	668 050 318		Kabelklammer		Cable for A.S.S. lock nut	Attache-câble	Pinza para cables
2	A06	1	668 060 277		Universalbürste	ø 45mm	Multiuse brush	Brosse multi-usage	Cepillo universal
2	A07	1	668 060 279		Einsatz für Staub		Dust insert	Insert pour la poussière	Inserto para polvo
2	A08	1	668 060 278		Einsatz für Flüssigkeiten		Brush for liquids suck up	Insert pour liquides	Inserto para líquidos
2	A09	1	668 050 080		Fugendüse	ø 45mm	Crevice nozzle	Tuyère à joint	Boquilla para ranuras
2	A10	1	668 050 089		Eckdüse	ø 45mm	Waste nozzle	Tuyère d'angle	Boquilla para ángulos
2	A11	1	668 070 123		Universaladapter, Gummi		Rubber universal adapter	Adaptateur	Adaptor
2	A12	1	668 083 100		Staubbeutel		P.P. bag	Sac à poussières	Bolsa recojepolvo
2	A13	1	668 083 035		Schaumstofffilter		Mousse-filter	Filtre en mousse	Filtro de plástico celular
2	A14	1	668 083 200		Papierpatrone		Small BIA cartridge filter package	Cartouche papier	Filtro de cartucho de papel
2	A15	1	668 083 201		Papierpatrone mit Aufnahme		Small BIA cartridge filter package + adapter disk	Cartouche papier avec récepteur	Filtro de cartucho con alojamiento
2	A16	1	668 083 134		Papierbeutel (5 Stck.)		Vertical paper bag package (5 pcs.)	Sac papier (5 pièces)	Bolsas de papel (5 uds.)

WD-2035	Inhaltsverzeichnis Index Table des matières Indice	
---------	---	---

1	Gehäuse, Motor	Case, motor	Carter, moteur	Carter, motor
2	Zubehör	Accessories	Accessoires	Accesorios

	Zeichenerklärung (D)	Key to symbols (GB)	Légende (F)	Explicación de símbolos (E)
⇒ 1999999 2000000 ⇒ 2003.04 ⇒ TI 2003/07 Acc. = { m Corr.	Produktion bis Serien-Nr. Neues Teil ab Serien-Nr. Neues Teil ab Jahr / Monat Siehe Technische Information Jahr / Nr. Zubehör (nicht im Lieferumfang) Keine Serienausführung, jedoch verwendbar Beinhaltet Positions-Nr. Meterware Druckfehlerberichtigung	Production to serial number New part from serial number New part from Year / Month See Technical Information Year / No. Accessories (not included in the delivery inventory) No standard execution, may be used Contains item number Sold by the meter Error correction	Production jusqu'à n° de série Nouveau pièce à partir du n° de série Nouveau pièce à partir de année / mois Voir information technique année / n° Accessoires (non compris dans la livraison) Aucune exécut. en série, cependant utilisable contient n° de numéro Au mètre Rectification d'erreurs	Producción hasta N° de serie Pieza nueva a partir de N° de serie Pieza nueva a partir de año / mes Véase inform. técnico año / N° Accesorios (no incluido en la extensión del suministro) No es de serie, pero sirve Contiene pos N° Por metro Fe de erratas
	Verklaring der tekens (NL)	Chiarificazione dei simboli (I)	Objasnitev znakov (SLO)	Επεξήγηση συμβόλων (GR)
⇒ 1999999 2000000 ⇒ 2003.04 ⇒ TI 2003/07 Acc. = { m Corr.	In productie tot serie-Nr. Nieuw onderdeel vanaf serie-Nr. Nieuw onderdeel vanaf jaar / maand Zie technische informatie jaar / Nr. Accessoires (niet meegeleverd) Geen serieuitvoering, maar wel bruikbaar Omvat Positie-Nr. Metergoed Drukfoutcorrectie	Produzione fino al n. di serie Nuovo pezzo a partire dal n. di serie Nuovo pezzo a partire dal anno / mese Vedere il inform. tecnici del anno / n. Accessori (non compresi nell'insieme di fornitura) Non è un modello di serie, ma ugualm. utilizza. Comprende la posizione n. Articoli a metraggio Rettifica di errori di stampa	Produkcija do serijske številke Novi del od serijske štev. dalje Novi del od leta / meseca dalje Glej tehnične informacije od leta / štev. Pritikline (niso v obsegu dostave) Ni serijska izvedba, a uporabno Vsebuje pozicijsko štev. Metrsko blago Popravek tiskovnih napak	Παραγωγή μέχρι τον αριθμό σειράς Νέο εξάρτημα από τον αριθμό σειράς Νέο εξάρτημα από το έτος / μήνα Βλέπε πληροφορίες του τεχνικά το έτος / αριθμό Πρόσθετα εξαρτήματα (δεν ανήκουν στη συσκευασία παράδοσης) Δεν έχει εκδοθεί σε σειρά, αλλά χρησιμοποιείται Περιλαμβάνει τον αριθμό θέσης Εμπόρευμα με το μέτρο Διόρθωση λάθους πίεσης

Änderungen vorbehalten
Specifications subject to change without notice
Changements sans préavis
Mejoras constructivas sin previo aviso