



Ersatzteilliste Spare Parts List

2019-01

TM10218H (2015-2019)

TM10220H2 (2015-2019)

TM12222H2 (2015-2019)

TM10218H, TM10220H2,
TM12222H2

(D, GB)

TM10218H (2015-2019) ,
TM10220H2 (2015-2019) ,
TM12222H2 (2015-2019)

1

Rahmensatz
Chassis

Makita

DOLMAR

=> 2017

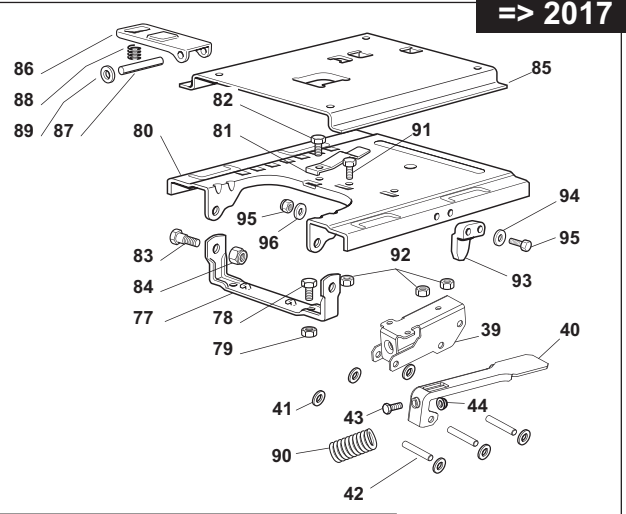

2018 =>

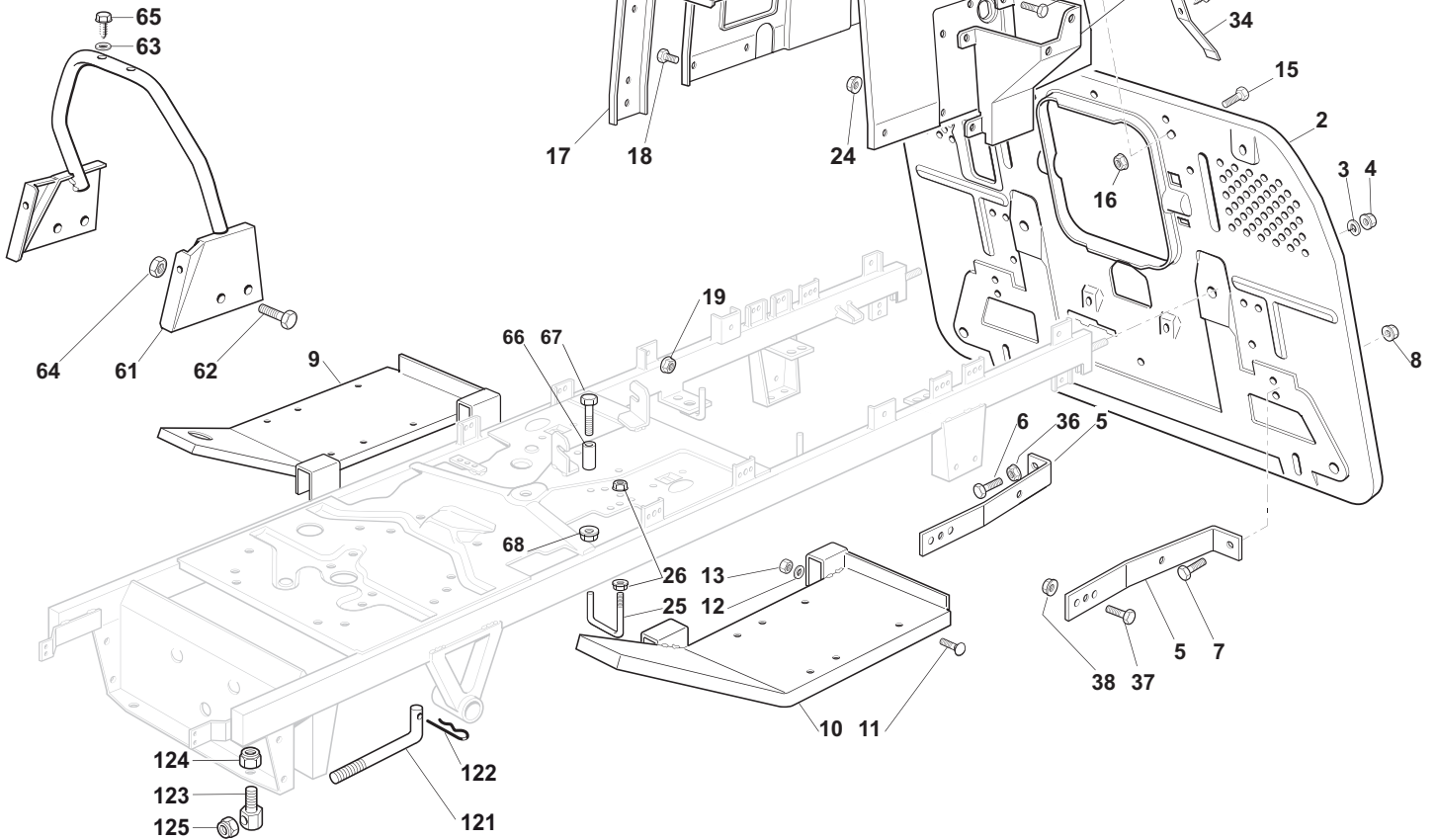
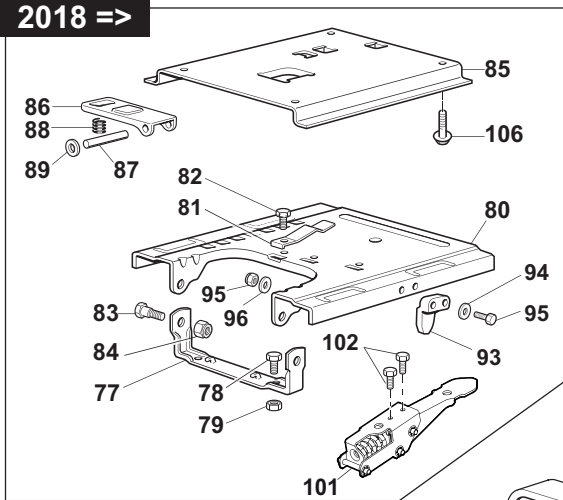

TM10218H (2015-2019) ,
 TM10220H2 (2015-2019) ,
 TM12222H2 (2015-2019)

1

Rahmensatz
 Chassis



Seite / Page	Pos.	TM10218H (2015-2019)	TM10220H2 (2015-2019)	TM12222H2 (2015-2019)	Teil-Nr. Part No.	Hinweise Notes	Bezeichnung	Spezifikation Specification	Description
1	2	1	1		664547051	=> 2017	PLATTE	102	PLATE
1	2	1	1		664470511	2018 =>	PLATTE	102	PLATE
1	2			1	664254705	=> 2017	PLATTE	122	PLATE
1	2			1	664470531	2018 =>	PLATTE	122	PLATE
1	3	2	2	2	664585100	=> 2017	FEDERRING		GROWER
1	4	2	2	2	664295200	=> 2017	MUTTER		NUT
1	4	2	2	2	664103122	2018 =>	FLANSCHMUTTER		FLANGE NUT
1	5	2	2	2	664774273		VERSTÄRKUNG		STIFFENING
1	6	1	1	1	664691100		SCHRAUBE		SCREW
1	7	3	3	3	664793102		SCHRAUBE		SCREW
1	8	4	4	4	664293201	=> 2017	MUTTER		NUT
1	8	4	4	4	664154220	2018 =>	MUTTER		NUT
1	9	1	1	1	664510041		FUSSBRETTHALTER RECHTS		SUPPORT
1	10	1	1	1	664510043		FUSSBRETTHALTER LINKS		SUPPORT
1	11	4	4	4	664815245		SCHRAUBE		SCREW
1	12	4	4	4	664523040		SCHEIBE		WASHER
1	13	4	4	4	664154510		MUTTER		NUT
1	14	1	1	1	664785133		SITZHALTER		SUPPORT
1	15	5	5	5	664791011		SCHRAUBE		SCREW
1	16	5	5	5	664292102		MUTTER		NUT
1	17	2	2	2	664650065		VERSTÄRKUNG		STIFFENING
1	18	6	6	6	664791011	=> 2017	SCHRAUBE		SCREW
1	18	6	6	6	664791201	2018 =>	SCHRAUBE		SCREW
1	19	6	6	6	664292102		MUTTER		NUT
1	20	1	1	1	664650067		VERSTÄRKUNG		STIFFENING
1	21	2	2	2	664360420		MUTTER		NUT
1	22	1	1	1	664785137		HALTER		SUPPORT
1	23	4	4	4	664791011	=> 2017	SCHRAUBE		SCREW
1	23	4	4	4	664791201	2018 =>	SCHRAUBE		SCREW
1	24	4	4	4	664292102		MUTTER		NUT
1	25	1	1	1	664580019		RIEMENFÜHRUNG		BELT GUIDE
1	26	2	2	2	664292102		MUTTER		NUT
1	34	1	1	1	664028542		FEDER		SPRING
1	35	1	1	1	664731580		SCHRAUBE		SCREW
1	36	1	1	1	664293200	=> 2017	MUTTER		NUT
1	36	1	1	1	664154220	2018 =>	MUTTER		NUT
1	37	2	2	2	664793102	=> 2017	SCHRAUBE		SCREW
1	37	2	2	2	664028536	2018 =>	SCHRAUBE		SCREW
1	38	2	2	2	664293201	=> 2017	MUTTER		NUT
1	38	2	2	2	664154220	2018 =>	MUTTER		NUT
1	39	1	1	1	664028511	=> 2017	BÜGEL		FULCRUM CLAMP
1	40	1	1	1	664028509	=> 2017	HEBEL		LEVER
1	41	6	6	6	664604896	=> 2017	SICHERUNGSSCHEIBE		SAFETY WASHER
1	42	3	3	3	664028479	=> 2017	BOLZEN		PIN
1	43	1	1	1	664028508	=> 2017	SCHRAUBE		SCREW
1	44	1	1	1	664154510		MUTTER		NUT
1	61	1	1	1	664650045		RAHMENSATZ		CHASSIS
1	62	4	4	4	664792611		SCHRAUBE		SCREW
1	63	4	4	4	664521330		SCHEIBE		WASHER
1	64	4	4	4	664292102		MUTTER		NUT
1	65	4	4	4	664731350		SCHRAUBE		SCREW
1	66	1	1	1	664167840		DISTANZSTÜCK		SPACER
1	67	1	1	1	664691200		SCHRAUBE		SCREW
1	68	1	1	1	664293201		MUTTER		NUT
1	71	2	2	2	664430205		FEDER		SPRING
1	72	2	2	2	664122000	=> 2017	SCHUTZKAPPE		HOOD
1	73	2	2	2	664943001		SCHRAUBE		SCREW
1	74	2	2	2	664293201	=> 2017	MUTTER		NUT
1	74	2	2	2	664154220	2018 =>	MUTTER		NUT
1	75	2	2	2	664523070		SCHEIBE		WASHER
1	77	1	1	1	664774207	=> 2017	BEFESTIGUNG FÜR SITZHALTER		SEAT CLAMP SUPPORT
1	77	1	1	1	664774305	2018 =>	BEFESTIGUNG FÜR SITZHALTER		SEAT CLAMP SUPPORT
1	78	2	2	2	664792611		SCHRAUBE		SCREW
1	79	2	2	2	664293201		MUTTER		NUT
1	80	1	1	1	664028543	=> 2017	SITZHALTER		SUPPORT
1	80	1	1	1	664785301	2018 =>	SITZHALTER		SUPPORT
1	81	1	1	1	664430203		RASTFEDER		SPRING
1	82	1	1	1	664731580		SCHRAUBE		SCREW
1	83	2	2	2	664524970		BOLZEN		PIN
1	84	2	2	2	664155010		MUTTER		NUT
1	85	1	1	1	664028544		SITZHALTER		SUPPORT
1	86	1	1	1	664318109		ABSTELLHEBEL		STOP LEVER
1	87	1	1	1	664510000		BOLZEN		PIN
1	88	1	1	1	664430202		FEDER		SPRING
1	89	2	2	2	664604897		SCHEIBE		WASHER
1	90	1	1	1	664028510	=> 2017	FEDER		SPRING
1	90	1	1	1	664430291	2018 =>	FEDER		SPRING

TM10218H (2015-2019) ,
 TM10220H2 (2015-2019) ,
 TM12222H2 (2015-2019)

1

Rahmensatz
 Chassis



2018 =>

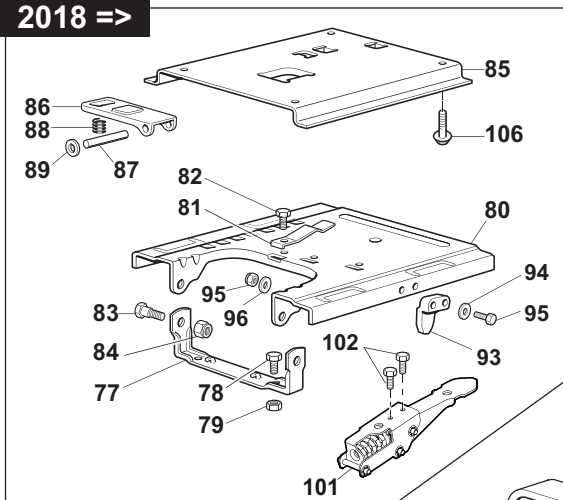

=> 2017

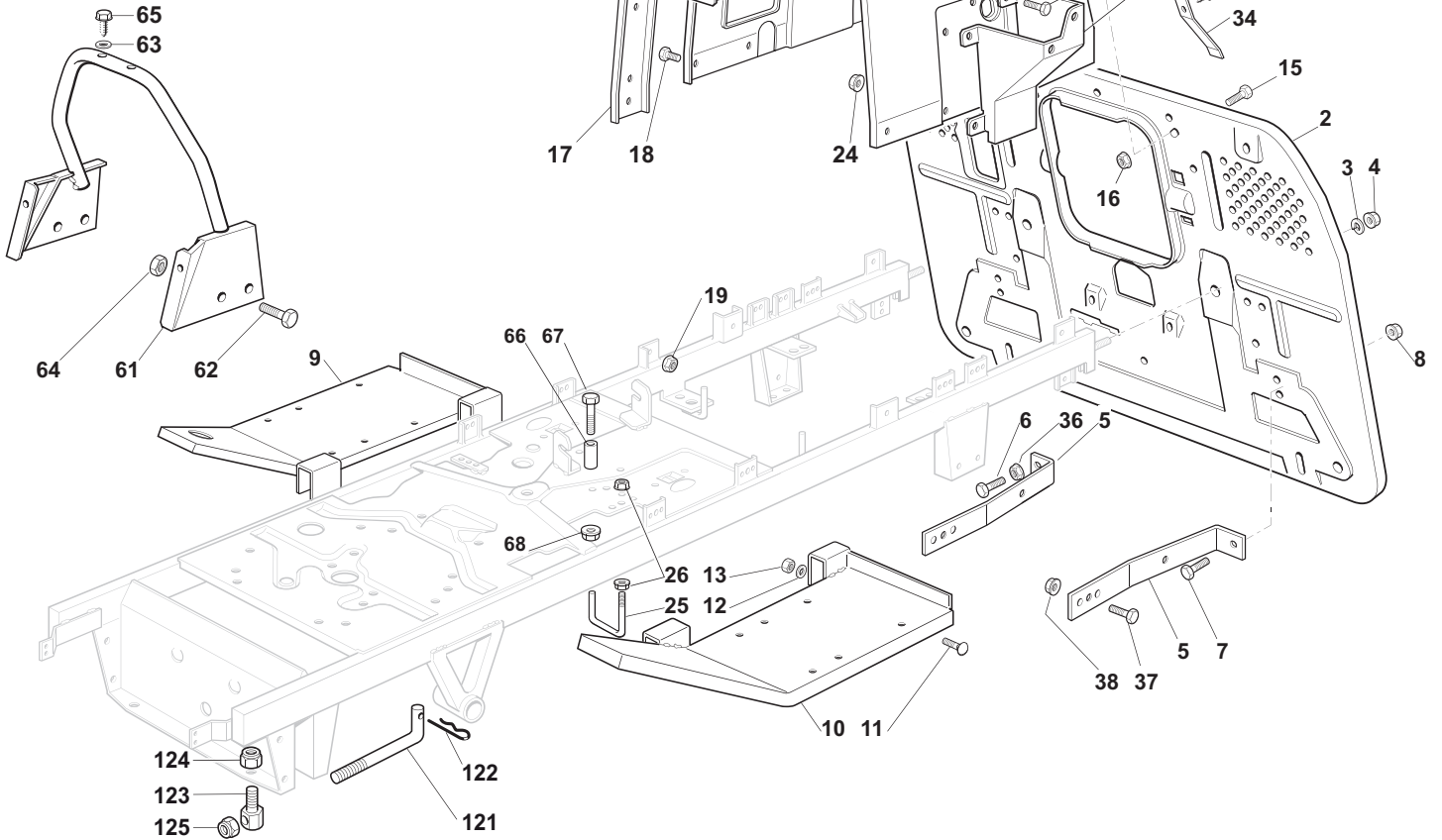
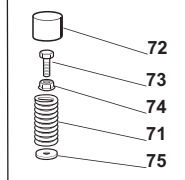
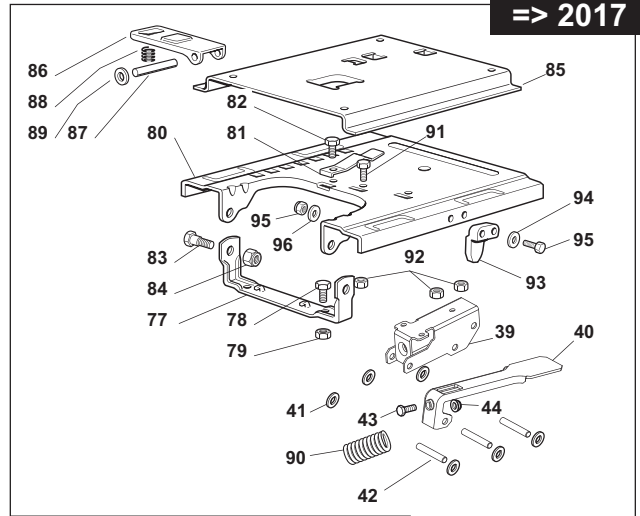

TM10218H (2015-2019) ,
 TM10220H2 (2015-2019) ,
 TM12222H2 (2015-2019)

1

Rahmensatz
 Chassis



Seite / Page	Pos.	TM10218H (2015-2019)	TM10220H2 (2015-2019)	TM12222H2 (2015-2019)	Teil-Nr. Part No.	Hinweise Notes	Bezeichnung	Spezifikation Specification	Description
1	91	1	1	1	664789000	=> 2017	SCHRAUBE		SCREW
1	92	1	1	1	664154330	=> 2017	MUTTER		NUT
1	93	1	1	1	664060049		NOCKEN		SWIVEL
1	94	2	2	2	664815050		SCHRAUBE		SCREW
1	95	4	4	4	664521320		SCHEIBE		WASHER
1	96	2	2	2	664154330		MUTTER		NUT
1	97	1	1	1	664755025	=> 2017	WINKEL		BRACKET
1	97	1	1	1	664550253	2018 =>	WINKEL		BRACKET
1	98	2	2	2	664735110	=> 2017	SCHRAUBE		SCREW
1	98	2	2	2	664789000	2018 =>	SCHRAUBE		SCREW
1	99	2	2	2	664437502	=> 2017	MUTTER		NUT
1	99	2	2	2	664053122	2018 =>	MUTTER		NUT
1	100	1	1	1	664430255		FEDER		SPRING
1	101	1	1	1	664318316	2018 =>	HEBEL KPL.		OPC SPRING AND LEVER ASSY
1	102	2	2	2	664028508	2018 =>	SCHRAUBE		SCREW
1	106	4	4	4	664590820	2018 =>	SCHRAUBE		SCREW
1	121	2	2	2	664510119		SPANNSTANGE		TIE ROD
1	122	2	2	2	664487997		SPLINT		COTTER PIN
1	123	2	2	2	664100402		BOLZEN		PIN
1	124	2	2	2	664155000		MUTTER		NUT
1	125	2	2	2	664155000		MUTTER		NUT

=> 2017

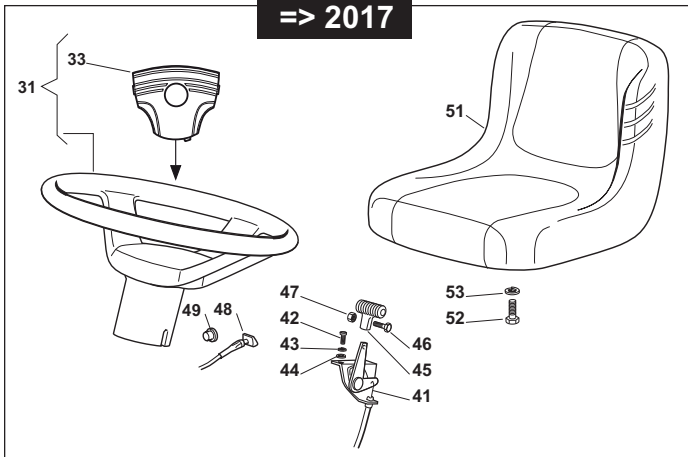

2018 =>

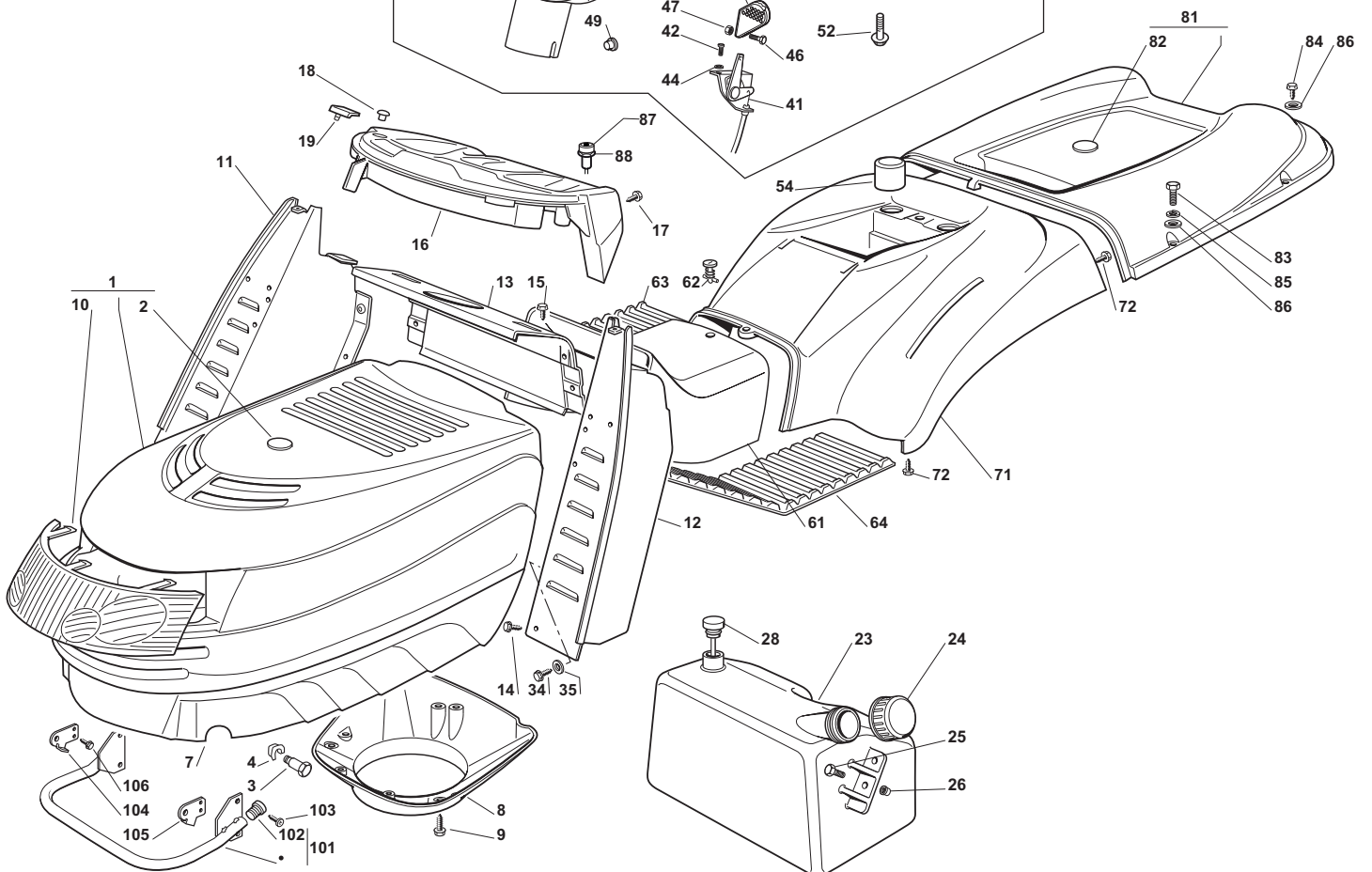
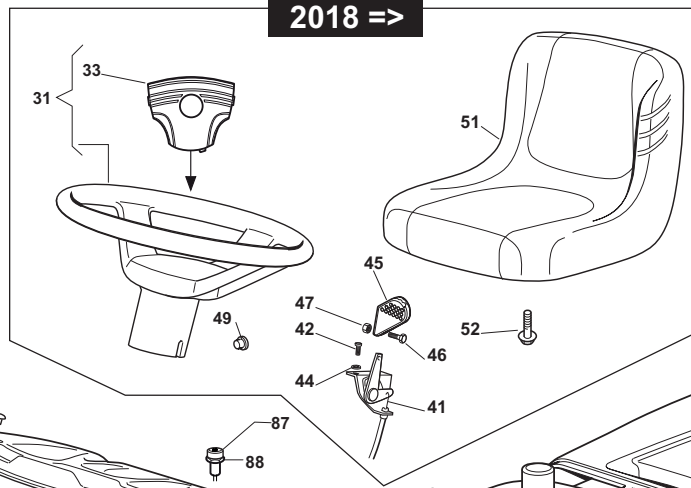

TM10218H (2015-2019) ,
 TM10220H2 (2015-2019) ,
 TM12222H2 (2015-2019)

2

Karosserie
 Body



Seite / Page	Pos.				Teil-Nr. Part No.	Hinweise Notes	Bezeichnung	Spezifikation Specification	Description
		TM10218H (2015-2019)	TM10220H2 (2015-2019)	TM12222H2 (2015-2019)					
2	1	1	1	1	664076938		OBERHAUBE	INC. 2,10	HOOD
2	2	1	1	1	664547103		PLATTE		PLATE
2	3	2	2	2	664510023		BOLZEN		PIN
2	4	2	2	2	664436050		PLATTE		PLATE
2	7	1	1	1	664076808		UNTERHAUBE		HOOD
2	8	1			664108028		ABDECKUNG		COVER
2	8		1	1	664108024		AUSWURFKANAL		CONVEYOR
2	9	3	3	3	664728686		SCHRAUBE		SCREW
2	10	1	1	1	664410859		FRONTTEIL		GRILL
2	11	1	1	1	664785022	=> 2017	KONSOLENHALTER RECHTS		SUPPORT
2	11	1	1	1	664502210	2018 =>	KONSOLENHALTER RECHTS		SUPPORT
2	12	1	1	1	664785021	=> 2017	KONSOLENHALTER LINKS		SUPPORT
2	12	1	1	1	664850219	2018 =>	KONSOLENHALTER LINKS		SUPPORT
2	13	1	1	1	664999137		HALTER		SUPPORT
2	14	2	2	2	664735110		SCHRAUBE		SCREW
2	15	4	4	4	664735110		SCHRAUBE		SCREW
2	16	1	1	1	664028545	=> 2017	KONSOLE		DASHBOARD
2	16	1	1	1	664120275	2018 =>	KONSOLE		DASHBOARD
2	16	1	1	1	664202751	2019 =>	KONSOLE		DASHBOARD
2	17	4	4	4	664728440		SCHRAUBE		SCREW
2	18	2	2	2	664120200		PFROPFEN		CAP
2	19	2	2	2	664260000		GUMMISTOPFEN		GROMMET
2	23		1	1	664999111		TANK		TANK
2	23	1			664999110		TANK		TANK
2	24	1	1	1	664795000		TANKVERSCHLUSS		CAP
2	25	2	2	2	664788910		SCHRAUBE	M5x16	SCREW
2	26	2	2	2	664500092		NIET		RIVET
2	28		1	1	664028546		KRAFTSTOFFMESSER		FUEL LEVEL INDICATOR
2	31	1	1	1	664961217		LENKRAD		STEERING WHEEL
2	33	1	1	1	664580503		ABDECKUNG		COVER
2	34	2	2	2	664731350		SCHRAUBE		SCREW
2	35	2	2	2	664521330		SCHEIBE		WASHER
2	41	1			664000200		GASZUG		BOWDEN CABLE
2	41		1	1	664000218	Corr.	GASZUG		BOWDEN CABLE
2	41		1	1	664000201		GASZUG		BOWDEN CABLE
2	42	2	2	2	664788512	=> 2017	SCHRAUBE		SCREW
2	42	2	2	2	664943012	2018 =>	SCHRAUBE		SCREW
2	43	2	2	2	664581200	=> 2017	FEDERRING		GROWER
2	44	2	2	2	664521310		SCHEIBE		WASHER
2	45	1	1	1	664592000	=> 2017	GRIFF		HANDLE
2	45	1	1	1	664920001	2018 =>	GRIFF		HANDLE
2	46	1	1	1	664726399		SCHRAUBE		SCREW
2	47	1	1	1	664290800		MUTTER		NUT
2	48		1	1	664090001	=> 2017	STARTER BETÄTIGUNG		CHOKE CONTROL
2	49	1	1	1	664120233	2018 => (TM10220H2, TM12222H2)	VERSCHLUSS		CAP
2	51	1	1	1	664028547		SITZ		SEAT
2	52	4	4	4	664793102	=> 2017	SCHRAUBE		SCREW
2	52	4	4	4	664590820	2018 =>	SCHRAUBE		SCREW
2	53	4	4	4	664583500	=> 2017	FEDERRING		GROWER
2	54	2	2	2	664122000		SCHUTZKAPPE		HOOD
2	61	1	1	1	664110099		ABDECKUNG, ROT		CAP, RED
2	62	1	1	1	664558002		STIFT		PIN
2	63	1	1	1	664110270		FUSSBRETTDECKEL RECHTS		RIGHT FOOTBOARD COVER
2	64	1	1	1	664110260		FUSSBRETTDECKEL LINKS		LEFT FOOTBOARD COVER
2	71	1	1	1	664109726		RADABDECKUNG, ROT		COVER, RED
2	72	4	4	4	664735402	=> 2017	SCHRAUBE		SCREW
2	72	4	4	4	664735403	2018 =>	SCHRAUBE		SCREW
2	81	1	1	1	664110206		HAUBE, ROT	INC. 82	COVER, RED
2	82	1	1	1	664547103		PLATTE		PLATE
2	83	2	2	2	664674701		SCHRAUBE		SCREW
2	84	4	4	4	664729601		SCHRAUBE		SCREW
2	85	2	2	2	664582101		FEDERRING		GROWER
2	86	6	6	6	664521331		LAGERBUCHSE		BUSHING
2	87	1	1	1	664028501		KNOPF		BUTTON
2	88	1	1	1	664028502		NUTMUTTER		RING NUT
2	101	1	1	1	664869006		AUSPUFFSCHUTZ	INC. 102	GUARD
2	102	2	2	2	664566110		PFROPFEN		CAP
2	103	4	4	4	664735120		SCHRAUBE		SCREW
2	104	1	1	1	664547089		PLATTE RECHTS		PLATE
2	105	1	1	1	664547091		PLATTE LINKS		PLATE
2	106	4	4	4	664731580		SCHRAUBE		SCREW

TM10218H (2015-2019) ,
TM10220H2 (2015-2019) ,
TM12222H2 (2015-2019)

3

Lenkgetriebe
Steering

Makita

DOLMAR

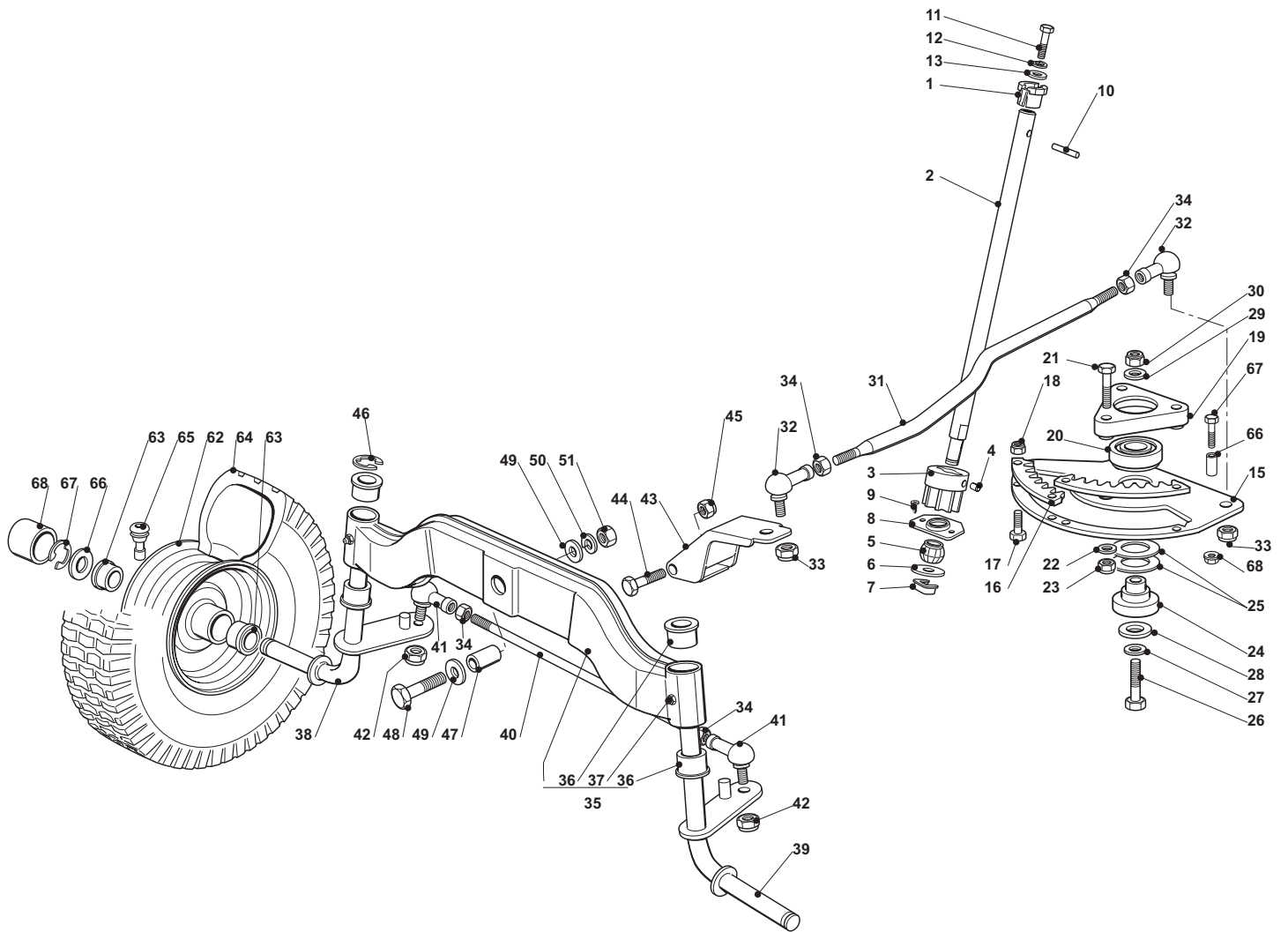

TM10218H (2015-2019) ,
 TM10220H2 (2015-2019) ,
 TM12222H2 (2015-2019)

3

Lenkgetriebe
 Steering



Seite / Page	Pos.	TM10218H (2015-2019)	TM10220H2 (2015-2019)	TM12222H2 (2015-2019)	Teil-Nr. Part No.	Hinweise Notes	Bezeichnung	Spezifikation Specification	Description
3	1	1	1	1	664038004		BUCHSE		BUSH
3	2	1	1	1	664552001		LENKSÄULE		STEERING COLUMN
3	3	1	1	1	664570004		RITZEL		PINION
3	4	1	1	1	664714300		STIFT		DOWEL
3	5	1	1	1	664743000		GELENK		JOINT
3	6	1	1	1	664523080		SCHEIBE		WASHER
3	7	1	1	1	664436030		PLÄTTCHEN		PLATE
3	8	1	1	1	664785213		HALTER		SUPPORT
3	9	2	2	2	664729601		SCHRAUBE		SCREW
3	10	1	1	1	664620250		STIFT		PIN
3	11	1	1	1	664691800		SCHRAUBE		SCREW
3	12	1	1	1	664583500		FEDERRING		GROWER
3	13	1	1	1	664523060	=> 2017	SCHEIBE		WASHER
3	13	1	1	1	664671651	2018 =>	SCHEIBE		WASHER
3	15	1	1	1	664735523	=> 2018	LENKWELLE		STEERING SHAFT
3	15	1	1	1	664355232	2019 =>	LENKWELLE		STEERING SHAFT
3	16	2	2	2	664515000		ZAHNSCHIENE		RACK
3	17	4	4	4	664791213		SCHRAUBE		SCREW
3	18	4	4	4	664154510		MUTTER		NUT
3	19	1	1	1	664774453		KLAMMER		CLAMP
3	20	1	1	1	664216047		KUGELLAGER		BALL BEARING
3	21	3	3	3	664691100		SCHRAUBE		SCREW
3	22	3	3	3	664523060	=> 2017	SCHEIBE		WASHER
3	22	3	3	3	664671651	2018 =>	SCHEIBE		WASHER
3	23	3	3	3	664155000		MUTTER		NUT
3	24	1	1	1	664510120		HALTER		SUPPORT
3	25	2	2	2	664672153		SCHEIBE		WASHER
3	26	1	1	1	664692395	=> 2017	SCHRAUBE		SCREW
3	26	1	1	1	664923952	2018 =>	SCHRAUBE		SCREW
3	27	1	1	1	664523080		SCHEIBE		WASHER
3	28	1	1	1	664521390		SCHEIBE		WASHER
3	29	1	1	1	664523080		SCHEIBE		WASHER
3	30	1	1	1	664156602		MUTTER		NUT
3	31	1	1	1	664033003		LENKSTAB		ROD
3	32	2	2	2	664746616		GELENK		JOINT
3	33	1	1	1	664746609		GELENK		JOINT
3	34	1	1	1	664156602		MUTTER		NUT
3	35	1	1	1	664998001		VORDERACHSE	INC. 36,37	FRONT WHEEL AXLE
3	36	4	4	4	664034002		BUCHSE		BUSH
3	37	2	2	2	664379511		FETTBUCHSE		GREASE DISPENSER
3	38	1	1	1	664230361		ACHSSCHENKEL RECHTS		STUB AXLE RIGHT
3	39	1	1	1	664230359		ACHSSCHENKEL LINKS		STUB AXLE LEFT
3	40	1	1	1	664840001		SPANNSTANGE		TIE ROD
3	41	2	2	2	664746616		GELENK		JOINT
3	42	2	2	2	664156602		MUTTER		NUT
3	43	1	1	1	664318185		HEBEL		LEVER
3	44	1	1	1	664692395	=> 2017	SCHRAUBE		SCREW
3	44	1	1	1	664923952	2018 =>	SCHRAUBE		SCREW
3	45	1	1	1	664155000		MUTTER		NUT
3	46	1	1	1	664001000		SPRENGRING		SNAP RING
3	47	1	1	1	664160005		DISTANZSTÜCK		SPACER
3	48	1	1	1	664694100		SCHRAUBE		SCREW
3	49	2	2	2	664521390		SCHEIBE		WASHER
3	50	1	1	1	664587900		FEDERRING		GROWER
3	51	1	1	1	664295800		MUTTER		NUT
3	62	2	2	2	664000598		VORDERRAD FELGE		RIMM
3	63	4	4	4	664122210		LAGER		BEARING
3	64	2	2	2	664590019	=> 2018	REIFEN	15 x 600-6	TYRE
3	64	2	2	2	664590020	2019 =>	REIFEN		TYRE
3	65	2	2	2	664950000		VENTIL		VALVE
3	66	2	2	2	664670005		SCHEIBE		WASHER
3	67	2	2	2	664001000		SPRENGRING		SNAP RING
3	68	2	2	2	664110230		NABENDECKEL		HUB COVER

TM10218H (2015-2019) ,
TM10220H2 (2015-2019) ,
TM12222H2 (2015-2019)

4y

Pedale für TUFF TORQ Getriebe
Drive and brake controls (TUFF TORQ)



Letzte Modelle mit **TUFF TORQ** Getriebe
Last models with **TUFF TORQ** transmission

TM10218H BIS / UP TO serial no. 409838 (24.01.2017)
TM10220H2 BIS / UP TO serial no. 401562 (10.03.2016)
TM12222H2 BIS / UP TO serial no. 412428 (24.02.2017)

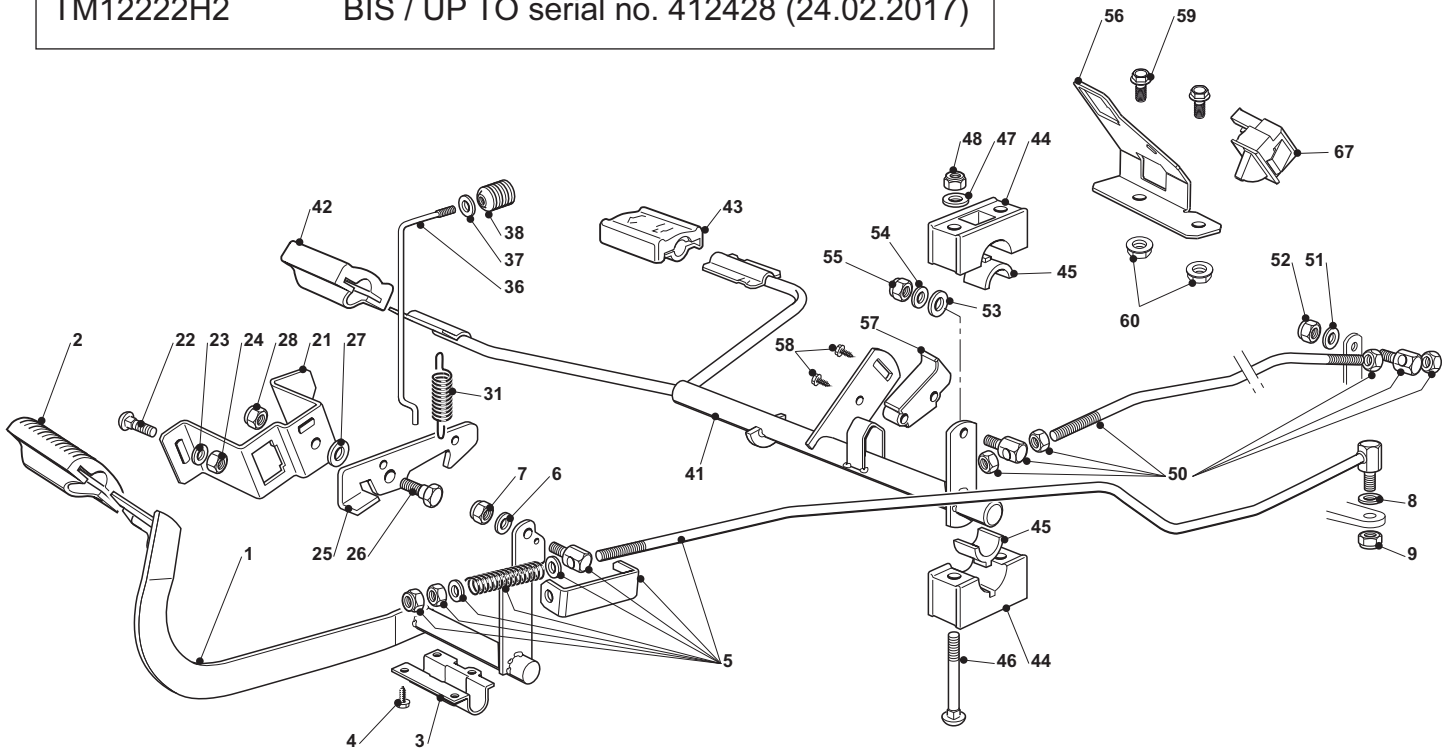

TM10218H (2015-2019) ,
 TM10220H2 (2015-2019) ,
 TM12222H2 (2015-2019)

4y

Pedale für TUFF TORQ Getriebe
 Drive and brake controls (TUFF TORQ)



Seite / Page	Pos.	TM10218H (2015-2019)	TM10220H2 (2015-2019)	TM12222H2 (2015-2019)	Teil-Nr. Part No.	Hinweise Notes	Bezeichnung	Spezifikation Specification	Description
4y	1	1	1	1	664500011	=> 2016/2017	PEDAL		PEDAL
4y	2	1	1	1	664110416	=> 2016/2017	PEDALGUMMI		PEDAL PAD
4y	3	1	1	1	664547081	=> 2016/2017	PLATTE		PLATE
4y	4	4	4	4	664731601	=> 2016/2017	SCHRAUBE		SCREW
4y	5	1	1	1	664000582	=> 2016/2017	STANGE KPL.		ROD CPL.
4y	6	1	1	1	664521350	=> 2016/2017	SCHEIBE		WASHER
4y	7	1	1	1	664155000	=> 2016/2017	MUTTER		NUT
4y	8	2	2	2	664521360	=> 2016/2017	SCHEIBE		WASHER
4y	9	1	1	1	664155000	=> 2016/2017	MUTTER		NUT
4y	21	1	1	1	664785143	=> 2016/2017	HALTER		SUPPORT
4y	22	2	2	2	664815210	=> 2016/2017	SCHRAUBE		SCREW
4y	23	1	1	1	664523040	=> 2016/2017	SCHEIBE		WASHER
4y	24	2	2	2	664154510	=> 2016/2017	MUTTER		NUT
4y	25	1	1	1	664253001	=> 2016/2017	HAKEN		HOOK
4y	26	1	1	1	664524970	=> 2016/2017	BOLZEN		PIN
4y	27	1	1	1	664670011	=> 2016/2017	SCHEIBE		WASHER
4y	28	1	1	1	664155000	=> 2016/2017	MUTTER		NUT
4y	31	1	1	1	664430213	=> 2016/2017	FEDER		SPRING
4y	36	1	1	1	664033034	=> 2016/2017	STANGE		ROD
4y	37	1	1	1	664523020	=> 2016/2017	SCHEIBE		WASHER
4y	38	1	1	1	664394509	=> 2016/2017	GRIFF		KNOB
4y	41	1	1	1	664028548	=> 2016/2017	GETRIEBEPEDAL		DRIVE PEDAL
4y	42	1	1	1	664110417	=> 2016/2017	PEDALGUMMI		PEDAL PAD
4y	43	1	1	1	664511041	=> 2016/2017	PEDALGUMMI		PEDAL PAD
4y	44	4	4	4	664785354	=> 2016/2017	HALTERSATZ		SUPPORT
4y	45	4	4	4	664034003	=> 2016/2017	BUCHSE		BUSH
4y	46	4	4	4	664815271	=> 2016/2017	SCHRAUBE		SCREW
4y	47	4	4	4	664523040	=> 2016/2017	SCHEIBE		WASHER
4y	48	4	4	4	664154510	=> 2016/2017	MUTTER		NUT
4y	50	1	1	1	664000579	=> 2016/2017	STANGE		ROD
4y	51	1	1	1	664523040	=> 2016/2017	SCHEIBE		WASHER
4y	52	1	1	1	664154510	=> 2016/2017	MUTTER		NUT
4y	53	1	1	1	664521360	=> 2016/2017	SCHEIBE		WASHER
4y	54	1	1	1	664523040	=> 2016/2017	SCHEIBE		WASHER
4y	55	1	1	1	664154510	=> 2016/2017	MUTTER		NUT
4y	56	1	1	1	664028549	=> 2016/2017	SCHALTERAUFNAHME		MICRO SWITCH BRACKET
4y	57	1	1	1	664028532	=> 2016/2017	NOCKEN		CAM
4y	58	1	1	1	664028533	=> 2016/2017	SCHRAUBE		SCREW
4y	59	2	2	2	664793102	=> 2016/2017	SCHRAUBE		SCREW
4y	60	2	2	2	664293201	=> 2016/2017	MUTTER		NUT
4y	67	1	1	1	664410614	=> 2016/2017	MIKROSCHALTER		MICRO SWITCH

TM10218H (2015-2019) ,
TM10220H2 (2015-2019) ,
TM12222H2 (2015-2019)

4ya

Pedale für HYDRO Getriebe
Drive and brake controls (HYDRO)



Erste Modelle mit **HYDRO** Getriebe
First models with **HYDRO** transmission

TM10218H	AB / FROM serial no. 425864 (01.02.2018)
TM10220H2	AB / FROM serial no. 420185 (16.10.2017)
TM12222H2	AB / FROM serial no. 433812 (29.10.2018)

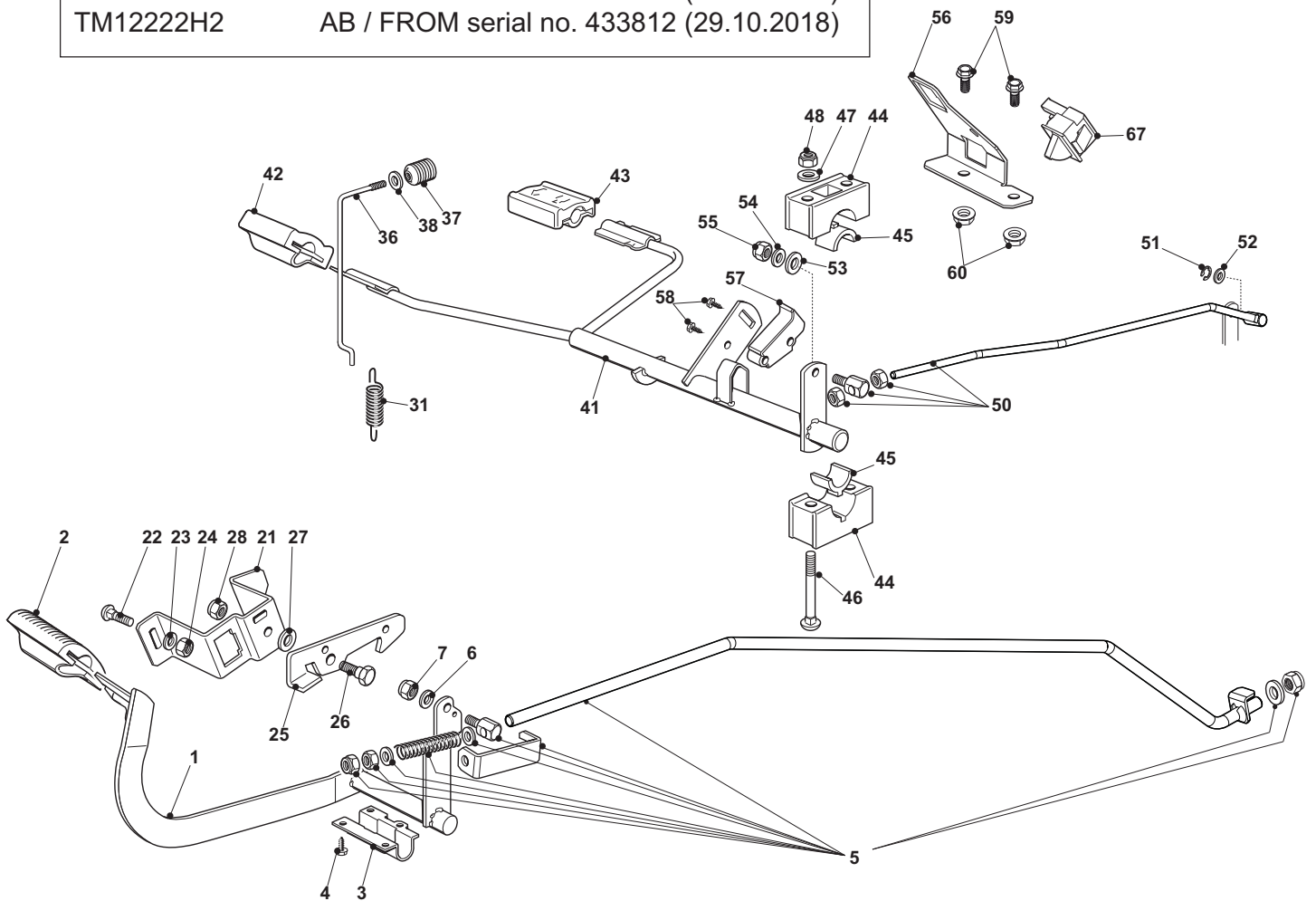

TM10218H (2015-2019) ,
 TM10220H2 (2015-2019) ,
 TM12222H2 (2015-2019)

4ya

Pedale für HYDRO Getriebe
 Drive and brake controls (HYDRO)



Seite / Page	Pos.	TM10218H (2015-2019)	TM10220H2 (2015-2019)	TM12222H2 (2015-2019)	Teil-Nr. Part No.	Hinweise Notes	Bezeichnung	Spezifikation Specification	Description
4ya 1	1	1	1	1	664500011	2017/2018 =>	PEDAL		PEDAL
4ya 2	1	1	1	1	664110416	2017/2018 =>	PEDALGUMMI		PEDAL PAD
4ya 3	1	1	1	1	664547081	2017/2018 =>	PLATTE		PLATE
4ya 4	4	4	4	4	664731601	2017/2018 =>	SCHRAUBE		SCREW
4ya 5	1	1	1	1	664000682	2017/2018 =>	STANGE KPL.		BRAKE ROD ASSY.
4ya 6	1	1	1	1	664521350	2017/2018 =>	SCHEIBE		WASHER
4ya 7	1	1	1	1	664155000	2017/2018 =>	MUTTER		NUT
4ya 21	1	1	1	1	664785143	2017/2018 =>	HALTER		SUPPORT
4ya 22	2	2	2	2	664815210	2017/2018 =>	SCHRAUBE		SCREW
4ya 23	1	1	1	1	664523040	2017/2018 =>	SCHEIBE		WASHER
4ya 24	2	2	2	2	664154510	2017/2018 =>	MUTTER		NUT
4ya 25	1	1	1	1	664253001	2017/2018 =>	HAKEN		HOOK
4ya 26	1	1	1	1	664524970	2017/2018 =>	BOLZEN		PIN
4ya 27	1	1	1	1	664670011	2017/2018 =>	SCHEIBE		WASHER
4ya 28	1	1	1	1	664155000	2017/2018 =>	MUTTER		NUT
4ya 31	1	1	1	1	664430213	2017/2018 =>	FEDER		SPRING
4ya 36	1	1	1	1	664033034	2017/2018 =>	STANGE		ROD
4ya 37	1	1	1	1	664394509	2017/2018 =>	GRIFF		KNOB
4ya 38	1	1	1	1	664523020	2017/2018 =>	SCHEIBE		WASHER
4ya 41	1	1	1	1	664028548	2017/2018 =>	GETRIEBEPEDAL		DRIVE PEDAL
4ya 42	1	1	1	1	664110417	2017/2018 =>	PEDALGUMMI		PEDAL PAD
4ya 43	1	1	1	1	664511041	2017/2018 =>	PEDALGUMMI		PEDAL PAD
4ya 44	4	4	4	4	664785354	2017/2018 =>	HALTERSATZ		SUPPORT
4ya 45	4	4	4	4	664034003	2017/2018 =>	BUCHSE		BUSH
4ya 46	4	4	4	4	664815271	2017/2018 =>	SCHRAUBE		SCREW
4ya 47	4	4	4	4	664523040	2017/2018 =>	SCHEIBE		WASHER
4ya 48	4	4	4	4	664154510	2017/2018 =>	MUTTER		NUT
4ya 50	1	1	1	1	664000681	2017/2018 =>	STANGE KPL.		ROD
4ya 51	1	1	1	1	664000940	2017/2018 =>	SICHERUNGSSCHEIBE		E-RING
4ya 52	1	1	1	1	664670011	2017/2018 =>	SCHEIBE		WASHER
4ya 53	2	2	2	2	664521360	2017/2018 =>	SCHEIBE		WASHER
4ya 54	5	5	5	5	664523040	2017/2018 =>	SCHEIBE		WASHER
4ya 55	1	1	1	1	664154510	2017/2018 =>	MUTTER		NUT
4ya 56	1	1	1	1	664028549	2017/2018 =>	SCHALTERAUFNAHME		MICRO SWITCH BRACKET
4ya 57	1	1	1	1	664028532	2017/2018 =>	NOCKEN		CAM
4ya 58	1	1	1	1	664028533	2017/2018 =>	SCHRAUBE		SCREW
4ya 59	2	2	2	2	664793102	2017/2018 =>	SCHRAUBE		SCREW
4ya 60	2	2	2	2	664154220	2017/2018 =>	MUTTER		NUT
4ya 67	1	1	1	1	664410614	2017/2018 =>	MIKROSCHALTER		MICRO SWITCH

TM10218H (2015-2019) ,
TM10220H2 (2015-2019) ,
TM12222H2 (2015-2019)

5a

Motor
Motor

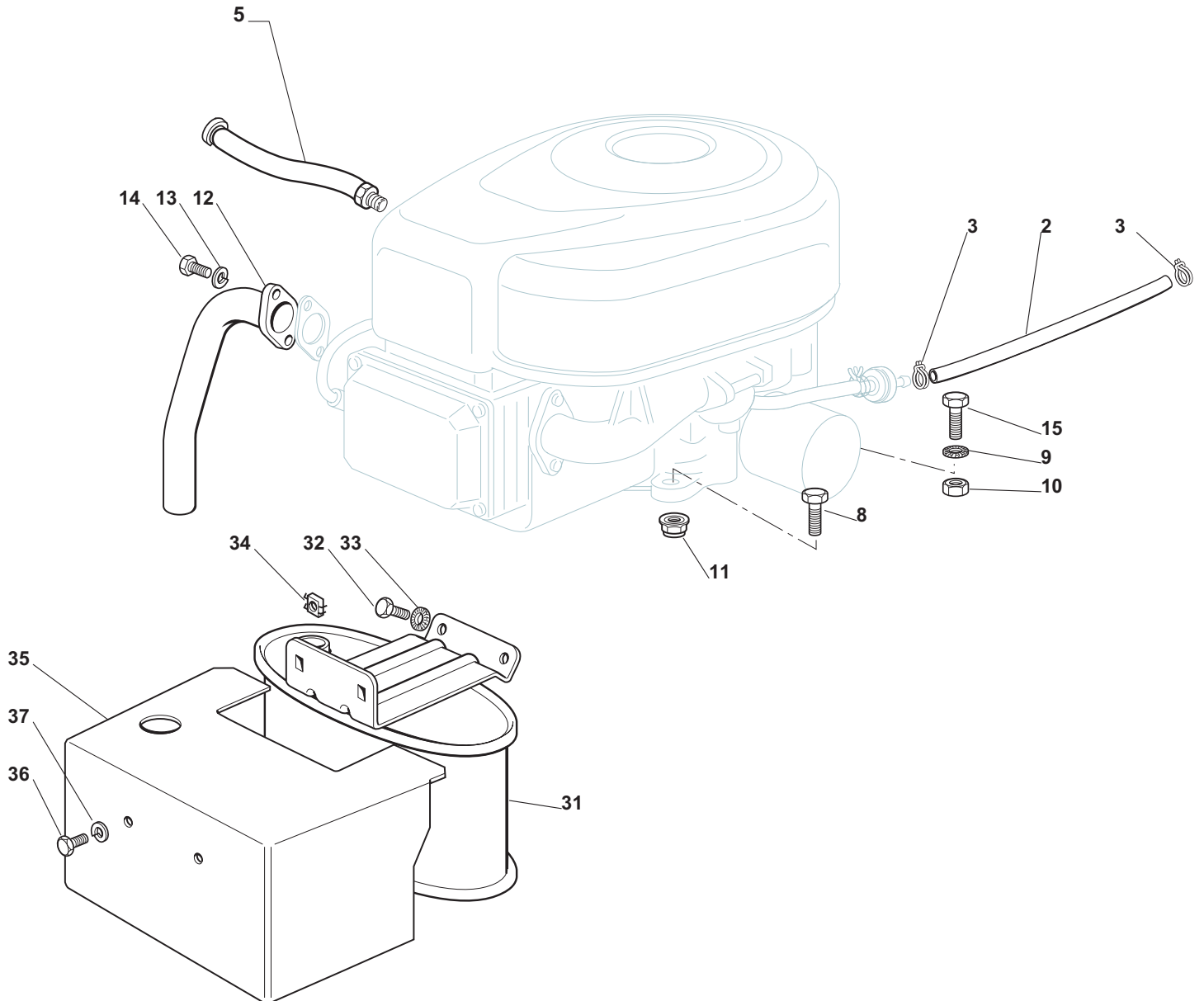

TM10218H (2015-2019) ,
 TM10220H2 (2015-2019) ,
 TM12222H2 (2015-2019)

5a

Motor
 Motor



Seite / Page	Pos.	Teil-Nr. Part No.	Hinweise Notes	Bezeichnung	Spezifikation Specification	Description
5a	2	1 664869016		VERBINDUNGSROHR		TUBE
5a	3	2 664375051		SCHLAUCHKLEMME		HOSE CLAMP
5a	5	1 664345827		ÖLABFLUSS		OIL DISCHARGE EXTENSION
5a	8	3 664691100		SCHRAUBE		SCREW
5a	9	1 664540260		SCHEIBE		WASHER
5a	10	1 664154210		MUTTER		NUT
5a	11	3 664154210		MUTTER		NUT
5a	12	1 664738206		ABGASSROHR		TUBE
5a	13	2 664583500		FEDERRING		GROWER
5a	14	2 664735530		SCHRAUBE		SCREW
5a	15	1 664691115		SCHRAUBE		SCREW
5a	31	1 664750010	=> 2018	SCHALLDÄMPFER		MUFFLER
5a	31	1 664750015	2019 =>	SCHALLDÄMPFER		MUFFLER
5a	32	2 664793102		SCHRAUBE		SCREW
5a	33	2 664540260		SCHEIBE		WASHER
5a	34	2 664360425		MUTTER		NUT
5a	35	1 664598009		SCHUTZ		PROTECTION
5a	36	2 664792611		SCHRAUBE		SCREW
5a	37	2 664583500		FEDERRING		GROWER

TM10218H (2015-2019) ,
TM10220H2 (2015-2019) ,
TM12222H2 (2015-2019)

5b

Motor
Motor

Makita

DOLMAR

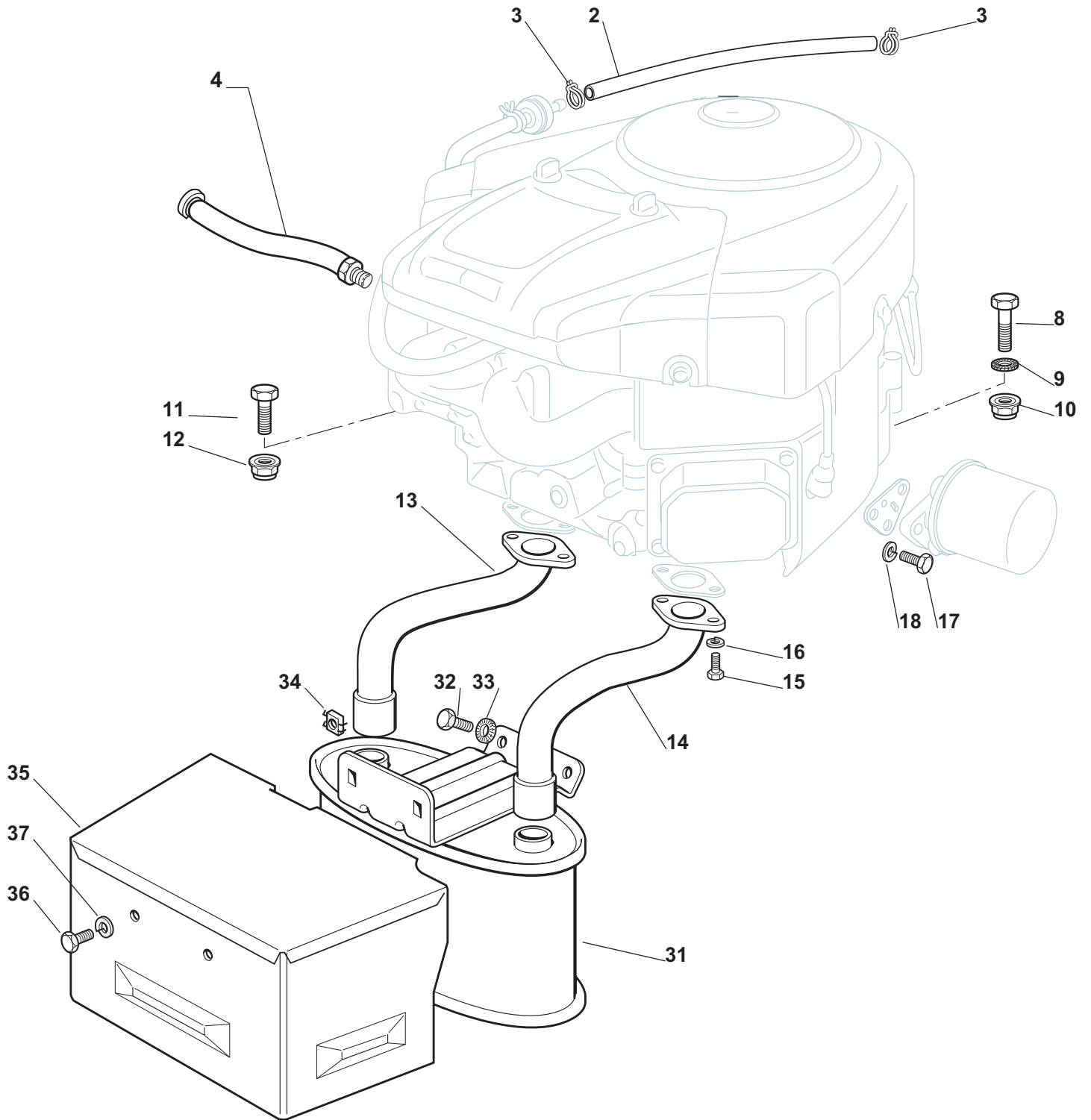

TM10218H (2015-2019) ,
 TM10220H2 (2015-2019) ,
 TM12222H2 (2015-2019)

5b

Motor
 Motor



Seite / Page	Pos.			Teil-Nr. Part No.	Hinweise Notes	Bezeichnung	Spezifikation Specification	Description
		TM10220H2 (2015-2019)	TM12222H2 (2015-2019)					
5b	2	1	1	664869016		VERBINDUNGSROHR		TUBE
5b	3	2	2	664375051		SCHLAUCHKLEMME		HOSE CLAMP
5b	4	1	1	664345827		ÖLABFLUSS		OIL DISCHARGE EXTENSION
5b	8	1	1	664691115		SCHRAUBE		SCREW
5b	9	1	1	664540260		SCHEIBE		WASHER
5b	10	1	1	664154210		MUTTER		NUT
5b	11	3	3	664691100		SCHRAUBE		SCREW
5b	12	3	3	664154210		MUTTER		NUT
5b	13	1	1	664738821		VERBINDUNGSROHR RECHTS		TUBE RIGHT
5b	14	1	1	664738215		VERBINDUNGSROHR LINKS		TUBE LEFT
5b	15	4	4	664735530		SCHRAUBE		SCREW
5b	16	4	4	664583500		FEDERRING		GROWER
5b	17	3	3	664791400		SCHRAUBE		SCREW
5b	18	3	3	664582100		FEDERRING		GROWER
5b	31	1	1	664028550		SCHALLDÄMPFER		EXHAUST MUFFLER
5b	32	2	2	664793102		SCHRAUBE		SCREW
5b	33	2	2	664540260		SCHEIBE		WASHER
5b	34	2	2	664360425		MUTTER		NUT
5b	35	1	1	664598005		SCHUTZ		PROTECTION
5b	36	2	2	664792611		SCHRAUBE		SCREW
5b	37	2	2	664583500		FEDERRING		GROWER

TM10218H (2015-2019) ,
TM10220H2 (2015-2019) ,
TM12222H2 (2015-2019)

6y

Getriebe TUFF TORQ
Gear TUFF TORQ



Letzte Modelle mit **TUFF TORQ** Getriebe
Last models with **TUFF TORQ** transmission

TM10218H	BIS / UP TO serial no. 409838 (24.01.2017)
TM10220H2	BIS / UP TO serial no. 401562 (10.03.2016)
TM12222H2	BIS / UP TO serial no. 412428 (24.02.2017)

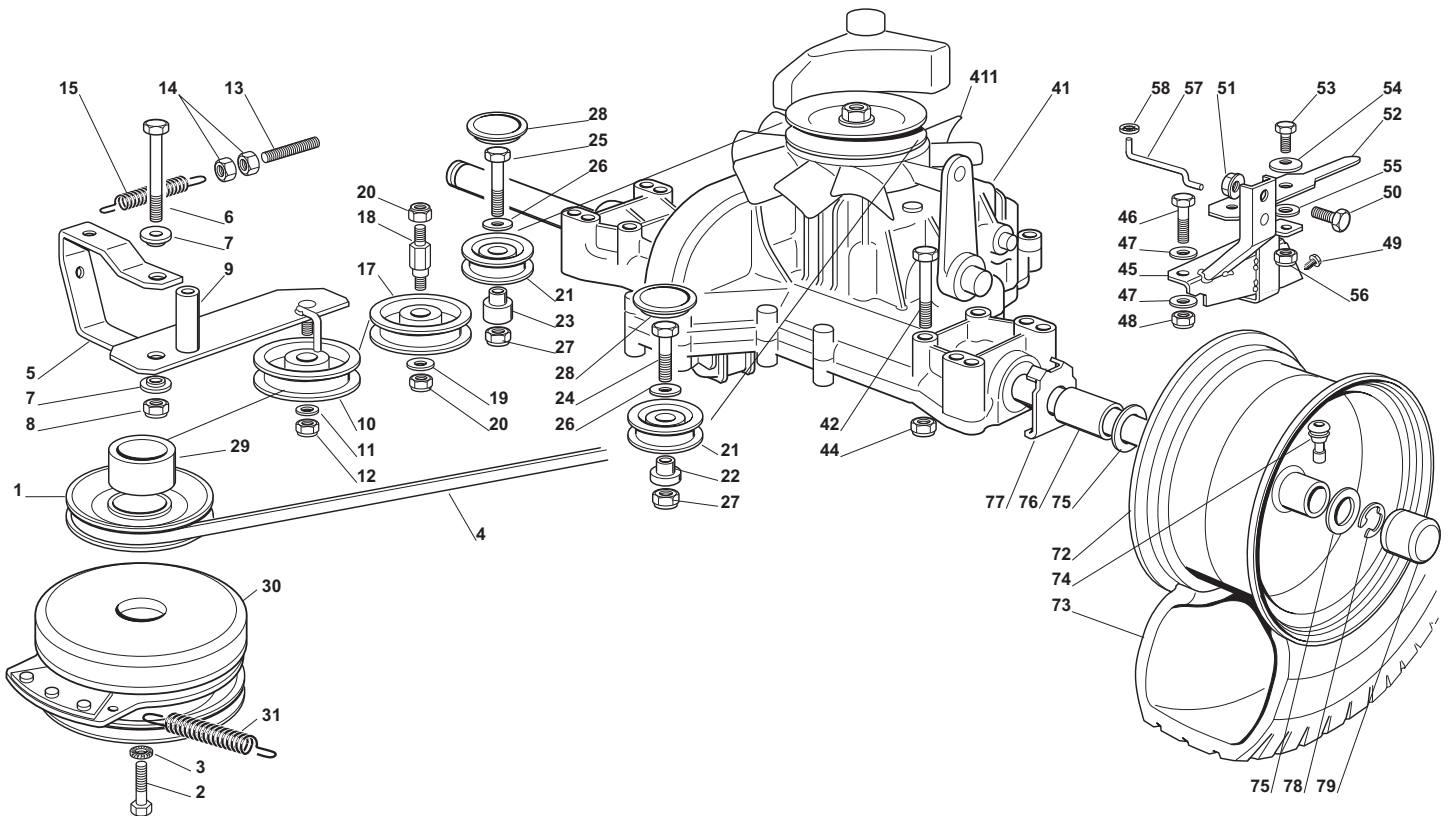

TM10218H (2015-2019) ,
 TM10220H2 (2015-2019) ,
 TM12222H2 (2015-2019)

6y

Getriebe TUFF TORQ
 Gear TUFF TORQ



Seite / Page	Pos.	TM10218H (2015-2019)	TM10220H2 (2015-2019)	TM12222H2 (2015-2019)	Teil-Nr. Part No.	Hinweise Notes	Bezeichnung	Spezifikation Specification	Description
6y	1	1	1	1	664601566	=> 2016/2017	RIEMENSCHLEIBE		PULLEY
6y	2	1	1	1	664737320	=> 2016/2017	SCHRAUBE		SCREW
6y	3	1	1	1	664543000	=> 2016/2017	SCHEIBE		WASHER
6y	4	1	1	1	664062001	=> 2016/2017	RIEMEN		BELT
6y	5	1	1	1	664318165	=> 2016/2017	HEBEL		LEVER
6y	6	1	1	1	664028551	=> 2016/2017	SCHRAUBE		SCREW
6y	7	2	2	2	664038002	=> 2016/2017	BUCHSE		BUSH
6y	8	1	1	1	664155000	=> 2016/2017	MUTTER		NUT
6y	9	1	1	1	664160027	=> 2016/2017	DISTANZSTÜCK		SPACER
6y	10	1	1	1	664601554	=> 2016/2017	RIEMENSCHLEIBE		PULLEY
6y	11	1	1	1	664523060	=> 2016/2017	SCHEIBE		WASHER
6y	12	1	1	1	664155000	=> 2016/2017	MUTTER		NUT
6y	13	1	1	1	664840010	=> 2016/2017	SPANNSTANGE		TIE ROD
6y	14	2	2	2	664293200	=> 2016/2017	MUTTER		NUT
6y	15	1	1	1	664430219	=> 2016/2017	FEDER		SPRING
6y	17	1	1	1	664028523	=> 2016/2017	RIEMENSCHLEIBE		PULLEY
6y	18	1	1	1	664510036	=> 2016/2017	BOLZEN		PIN
6y	19	1	1	1	664523060	=> 2016/2017	SCHEIBE		WASHER
6y	20	2	2	2	664155000	=> 2016/2017	MUTTER		NUT
6y	21	2	2	2	664601570	=> 2016/2017	RIEMENSCHLEIBE		PULLEY
6y	22	1	1	1	664160030	=> 2016/2017	DISTANZSTÜCK LINKS		SPACER
6y	23	1	1	1	664160024	=> 2016/2017	DISTANZSTÜCK RECHTS		SPACER
6y	24	1	1	1	664691115	=> 2016/2017	SCHRAUBE		SCREW
6y	25	1	1	1	664691400	=> 2016/2017	SCHRAUBE		SCREW
6y	26	2	2	2	664523060	=> 2016/2017	SCHEIBE		WASHER
6y	27	2	2	2	664155000	=> 2016/2017	MUTTER		NUT
6y	28	2	2	2	664109521	=> 2016/2017	DECKEL		COVER
6y	29	1	1	1	664600590	=> 2016/2017	DISTANZBUCHSE		SPACER
6y	30	1	1	1	664399062	=> 2016/2017	KUPPLUNG		CLUTCH
6y	31	1	1	1	664430210	=> 2016/2017	FEDER		SPRING
6y	41	1	1	1	664400950	=> 2016/2017	HINTERACHSE KPL.	Tuff-Torq K46F	REAR AXLE ASSY.
6y	411	1	1	1	664083050	=> 2016/2017	LÜFTERRAD		FAN
6y	42	4	4	4	664691800	=> 2016/2017	SCHRAUBE		SCREW
6y	44	4	4	4	664154210	=> 2016/2017	MUTTER		NUT
6y	45	1	1	1	664999109	=> 2016/2017	HALTER		SUPPORT
6y	46	1	1	1	664691200	=> 2016/2017	SCHRAUBE		SCREW
6y	47	2	2	2	664521350	=> 2016/2017	SCHEIBE		WASHER
6y	48	1	1	1	664155000	=> 2016/2017	MUTTER		NUT
6y	49	2	2	2	664735120	=> 2016/2017	SCHRAUBE		SCREW
6y	50	1	1	1	664792611	=> 2016/2017	SCHRAUBE		SCREW
6y	51	1	1	1	664293201	=> 2016/2017	MUTTER		NUT
6y	52	1	1	1	664318157	=> 2016/2017	HEBEL		LEVER
6y	53	1	1	1	664793102	=> 2016/2017	SCHRAUBE		SCREW
6y	54	1	1	1	664369500	=> 2016/2017	FEDERSCHLEIBE		ELASTIC WASHER
6y	55	1	1	1	664670011	=> 2016/2017	SCHEIBE		WASHER
6y	56	1	1	1	664155000	=> 2016/2017	MUTTER		NUT
6y	57	1	1	1	664033033	=> 2016/2017	STANGE		ROD
6y	58	1	1	1	664604896	=> 2016/2017	SICHERUNGSSCHLEIBE		SAFETY WASHER
6y	72	2	2	2	664000599	=> 2016/2017	HINTERRAD FELGE		RIMM
6y	73	2	2	2	664590015	=> 2016/2017	REIFEN		TYRE
6y	74	2	2	2	664950000	=> 2016/2017	VENTIL		VALVE
6y	75	4	4	4	664670005	=> 2016/2017	SCHEIBE		WASHER
6y	76	2	2	2	664160023	=> 2016/2017	DISTANZSTÜCK		SPACER
6y	77	2	2	2	664670025	=> 2016/2017	SCHEIBE		WASHER
6y	78	2	2	2	664001010	=> 2016/2017	SICHERUNGSSCHLEIBE		LOCK WASHER
6y	79	2	2	2	664110230	=> 2016/2017	NABENDECKEL		HUB COVER

TM10218H (2015-2019) ,
 TM10220H2 (2015-2019) ,
 TM12222H2 (2015-2019)

6ya

Getriebe HYDRO
 Gear HYDRO



Erste Modelle mit **HYDRO** Getriebe
 First models with **HYDRO** transmission

TM10218H	AB / FROM serial no. 425864 (01.02.2018)
TM10220H2	AB / FROM serial no. 420185 (16.10.2017)
TM12222H2	AB / FROM serial no. 433812 (29.10.2018)

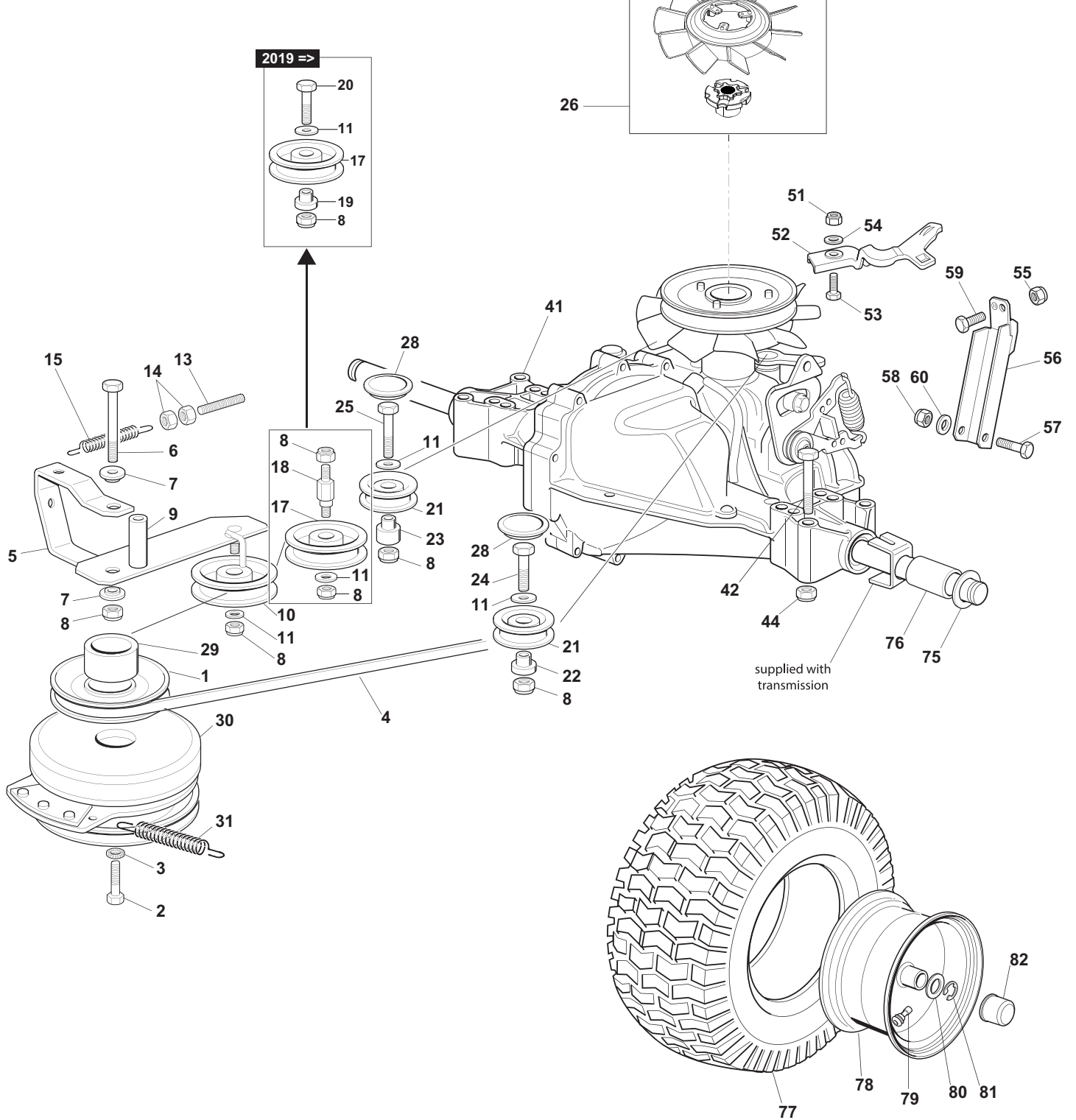

TM10218H (2015-2019) ,
 TM10220H2 (2015-2019) ,
 TM12222H2 (2015-2019)

6ya

Getriebe HYDRO
 Gear HYDRO



Seite / Page	Pos.	TM10218H (2015-2019)	TM10220H2 (2015-2019)	TM12222H2 (2015-2019)	Teil-Nr. Part No.	Hinweise Notes	Bezeichnung	Spezifikation Specification	Description
6ya 1	1	1	1	1	664601577	2017/2018 =>	RIEMENSCHLEIBE		BELT PULLEY
6ya 2	1	1	1	1	664737320	2017/2018 =>	SCHRAUBE		SCREW
6ya 3	1	1	1	1	664543000	2017/2018 =>	SCHEIBE		WASHER
6ya 4	1	1	1	1	664062019	2017/2018 =>	KEILREIMEN		TRAPEZOIDAL BELT
6ya 5	1	1	1	1	664318165	2017/2018 =>	HEBEL		LEVER
6ya 6	1	1	1	1	664028551	2017/2018 =>	SCHRAUBE		SCREW
6ya 7	2	2	2	2	664038002	2017/2018 =>	BUCHSE		BUSH
6ya 8	9	9	9	9	664155000	2017/2018 =>	MUTTER		NUT
6ya 9	1	1	1	1	664160027	2017/2018 =>	DISTANZSTÜCK		SPACER
6ya 10	1	1	1	1	664601554	2017/2018 =>	RIEMENSCHLEIBE		PULLEY
6ya 11	5	5	5	5	664523060	2017/2018 =>	SCHEIBE		WASHER
6ya 13	1	1	1	1	664840010	2017/2018 =>	SPANNSTANGE		TIE ROD
6ya 14	2	2	2	2	664293200	2017/2018 =>	MUTTER		NUT
6ya 15	1	1	1	1	664430219	2017/2018 =>	FEDER		SPRING
6ya 17	1	1	1	1	664028523	2017/2018 =>	RIEMENSCHLEIBE		PULLEY
6ya 18	1	1	1	1	664028566	2017/2018 =>	BOLZEN		PIN
6ya 19	1	1	1	1	664160056	2019 =>	DISTANZBUCHSE		SPACER
6ya 20	1	1	1	1	664691800	2017/2018 =>	SCHRAUBE		SCREW
6ya 21	2	2	2	2	664601570	2017/2018 =>	RIEMENSCHLEIBE		PULLEY
6ya 22	1	1	1	1	664160030	2017/2018 =>	DISTANZSTÜCK LINKS		SPACER
6ya 23	1	1	1	1	664160024	2017/2018 =>	DISTANZSTÜCK RECHTS		SPACER
6ya 24	1	1	1	1	664691115	2017/2018 =>	SCHRAUBE		SCREW
6ya 25	1	1	1	1	664691400	2017/2018 =>	SCHRAUBE		SCREW
6ya 26	2	2	2	2	664802723	2017/2018 =>	LÜFTERRAD-SET		FAN KIT
6ya 27	1	1	1	1	664870130	2017/2018 =>	LÜFTERRAD		FAN
6ya 28	2	2	2	2	664109521	2017/2018 =>	DECKEL		COVER
6ya 29	1	1	1	1	664028539	2017/2018 =>	DISTANZBUCHSE		SPACER
6ya 30	1	1	1	1	664399060	2017/2018 =>	KUPPLUNG		CLUTCH
6ya 31	1	1	1	1	664430210	2017/2018 =>	FEDER		SPRING
6ya 41	1	1	1	1	664400990	2017/2018 =>	ANTRIEB KPL.	HYG T2	TRANSMISSION UNIT
6ya 42	4	4	4	4	664691600	2017/2018 =>	SCHRAUBE		SCREW
6ya 44	4	4	4	4	664154210	2017/2018 =>	MUTTER		NUT
6ya 51	1	1	1	1	664154510	2017/2018 =>	MUTTER		NUT
6ya 52	1	1	1	1	664318253	2017/2018 =>	HEBEL		LEVER
6ya 53	1	1	1	1	664791213	2017/2018 =>	SCHRAUBE		SCREW
6ya 54	1	1	1	1	664523040	2017/2018 =>	SCHEIBE		WASHER
6ya 55	1	1	1	1	664293201	2017/2018 =>	MUTTER		NUT
6ya 56	1	1	1	1	664785199	2017/2018 =>	HALTER		SUPPORT
6ya 57	1	1	1	1	664691700	2017/2018 =>	SCHRAUBE		SCREW
6ya 58	1	1	1	1	664155000	2017/2018 =>	MUTTER		NUT
6ya 59	1	1	1	1	664793102	2017/2018 =>	SCHRAUBE		SCREW
6ya 60	1	1	1	1	664521350	2017/2018 =>	SCHEIBE		WASHER
6ya 75	4	4	4	4	664670005	2017/2018 =>	SCHEIBE		WASHER
6ya 76	2	2	2	2	664160023	2017/2018 =>	DISTANZSTÜCK		SPACER
6ya 77	2	2	2	2	664590021	2017/2018 =>	REIFEN		TYRE
6ya 78	2	2	2	2	664000596	2017/2018 =>	FELGE		RIMM
6ya 79	2	2	2	2	664950000	2017/2018 =>	VENTIL		VALVE
6ya 80	2	2	2	2	664670005	2017/2018 =>	SCHEIBE		WASHER
6ya 81	2	2	2	2	664001010	2017/2018 =>	SICHERUNGSSCHLEIBE		LOCK WASHER
6ya 82	2	2	2	2	664110230	2017/2018 =>	NABENDECKEL		HUB COVER

TM10218H (2015-2019) ,
 TM10220H2 (2015-2019) ,
 TM12222H2 (2015-2019)

7

Scheidwerkzeug Aufhebesatz
 Cutting plate lifting

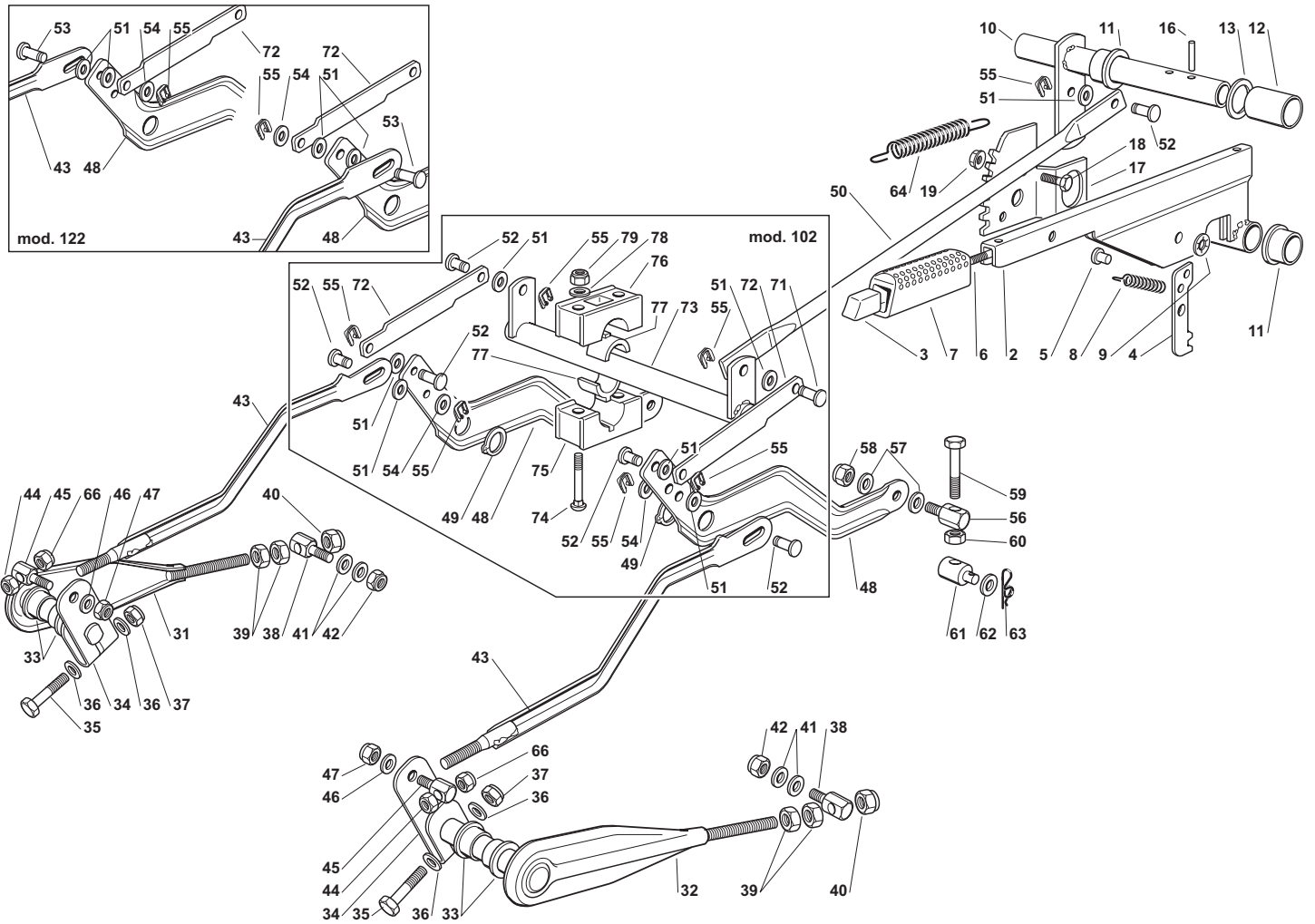

TM10218H (2015-2019) ,
 TM10220H2 (2015-2019) ,
 TM12222H2 (2015-2019)

7

Schneidwerkzeug Aufhebesatz
 Cutting plate lifting



Seite / Page	Pos.	TM10218H (2015-2019)	TM10220H2 (2015-2019)	TM12222H2 (2015-2019)	Teil-Nr. Part No.	Hinweise Notes	Bezeichnung	Spezifikation Specification	Description
7	2	1	1	1	664318139	=> 2017	HEBEL		LEVER
7	2	1	1	1	664181391	2018 =>	HEBEL		LEVER
7	3	1	1	1	664470901	=> 2017	AUSLÖSER		TRIGGER
7	3	1	1	1	664605000	2018 =>	DRUCKKNOPF		BUTTON
7	4	1	1	1	664470901		AUSLÖSER		TRIGGER
7	5	1	1	1	664510011		BOLZEN		PIN
7	6	1	1	1	664033002		STAB		ROD
7	7	1	1	1	664394536		GRIFF		KNOB
7	8	1	1	1	664430208		FEDER		SPRING
7	9	1	1	1	664604899		SICHERUNGSSCHEIBE		SAFETY WASHER
7	10	1	1	1	664000551		ACHSE		AXLE
7	11	3	3	3	664034523		BUCHSE		BUSH
7	12	1	1	1	664160025		DISTANZSTÜCK		SPACER
7	13	1	1	1	664672153		SCHEIBE		WASHER
7	16	2	2	2	664620206		STIFT		PIN
7	17	1	1	1	664735506		SEKTOR		SECTOR
7	18	2	2	2	664792611		SCHRAUBE		SCREW
7	19	2	2	2	664293201	=> 2017	MUTTER		NUT
7	19	2	2	2	664154220	2018 =>	MUTTER		NUT
7	31	1	1		664318155		VORDERHEBEL RECHTS		FRONT LEVER RIGHT
7	31			1	664318159		VORDERHEBEL RECHTS		FRONT LEVER RIGHT
7	32	1	1		664999157		VORDERHEBEL LINKS		FRONT LEVER LEFT
7	32			1	664999161		VORDERHEBEL LINKS		FRONT LEVER LEFT
7	33	4	4	4	664040605		BUCHSE		BUSH
7	34	2	2	2	664318161		HEBEL		LEVER
7	35	2	2	2	664691700		SCHRAUBE		SCREW
7	36	4	4	4	664521350		SCHEIBE		WASHER
7	37	2	2	2	664155000		MUTTER		NUT
7	38	2	2	2	664510056		BOLZEN		PIN
7	39	4	4	4	664295200		MUTTER		NUT
7	40	2	2	2	664156602		MUTTER		NUT
7	41	4	4	4	664670008		SCHEIBE		WASHER
7	42	2	2	2	664156602		MUTTER		NUT
7	43	2	2	2	664000477		VERBINDUNGSSTAB		CONNECTING ROD
7	44	2	2	2	664155000		MUTTER		NUT
7	45	2	2	2	664510055		BOLZEN		PIN
7	46	2	2	2	664521350		SCHEIBE		WASHER
7	47	2	2	2	664155000		MUTTER		NUT
7	48	2	2	2	664318153		HEBEL		LEVER
7	49	2	2	2	664609255		SICHERUNGSRING		RETAINING RING
7	50	2	2	2	664033071		VERBINDUNGSSTAB		CONNECTING ROD
7	51	6	6	6	664670011		SCHEIBE		WASHER
7	52	6	6	2	664510053		BOLZEN		PIN
7	53			2	664510048		BOLZEN		PIN
7	54	2	2	2	664521350		SCHEIBE		WASHER
7	55	6	6	4	664436050		PLATTE		PLATE
7	56	2	2	2	664510056		BOLZEN		PIN
7	57	4	4	4	664670008		SCHEIBE		WASHER
7	58	2	2	2	664156602		MUTTER		NUT
7	59	2	2		664794980		SCHRAUBE		SCREW
7	59			2	664794985		SCHRAUBE		SCREW
7	60	2	2	2	664295200		MUTTER		NUT
7	61	2	2	2	664510070		BOLZEN		PIN
7	62	2	2	2	664523090		SCHEIBE		WASHER
7	63	2	2	2	664487998		SPLINT		COTTER PIN
7	64	1	1	1	664430218		FEDER		SPRING
7	66	2	2	2	664293200		MUTTER		NUT
7	71	1	1	1	664510048		BOLZEN		PIN
7	72	2	2	2	664318223		HEBEL		CONNECTING LIFT LEVER
7	73	1	1	1	664000585		ACHSE		AXLE
7	74	4	4	4	664815271		SCHRAUBE		SCREW
7	75	2	2	2	664785355		HALTERSATZ		SUPPORT
7	76	2	2	2	664785354		HALTERSATZ		SUPPORT
7	77	4	4	4	664034003		BUCHSE		BUSH
7	78	4	4	4	664523040		SCHEIBE		WASHER
7	79	4	4	4	664154510		MUTTER		NUT

TM10218H (2015-2019) ,
TM10220H2 (2015-2019) ,
TM12222H2 (2015-2019)

8

Schneidwerkzeug (1)
Cutting plate (1)

Makita

DOLMAR

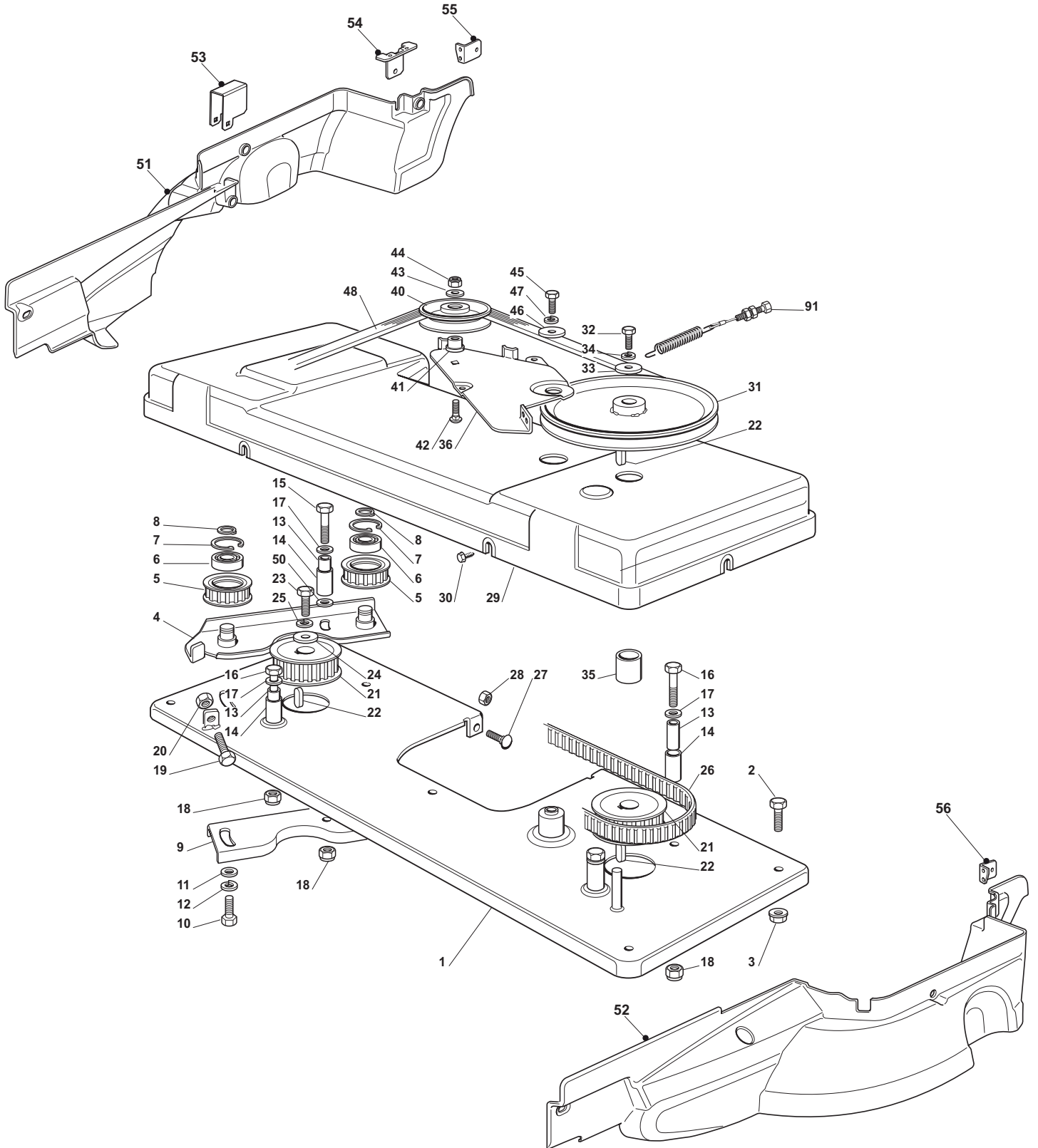

TM10218H (2015-2019) ,
 TM10220H2 (2015-2019) ,
 TM12222H2 (2015-2019)

8

Schneidwerkzeug (1)
 Cutting plate (1)



Seite / Page	Pos.	TM10218H (2015-2019)	TM10220H2 (2015-2019)	TM12222H2 (2015-2019)	Teil-Nr. Part No.	Hinweise Notes	Bezeichnung	Spezifikation Specification	Description
8	1	1	1		664547029		PLATTE	mod. 102	PLATE
8	1			1	664547031		PLATTE	mod. 122	PLATE
8	2	4	4	4	664792611	=> 2017	SCHRAUBE		SCREW
8	2	4	4	4	664793102	2018 =>	SCHRAUBE		SCREW
8	3	4	4	4	664293201	=> 2017	MUTTER		NUT
8	3	4	4	4	664154220	2018 =>	MUTTER		NUT
8	4	1	1	1	664785084	=> 2017	HALTERSATZ		SUPPORT
8	4	1	1		664850843	2018 =>	HALTERSATZ		SUPPORT
8	4			1	664278524	2018 =>	HALTERSATZ		SUPPORT
8	5	2	2		664601559		RIEMENSCHLEIBE		PULLEY
8	5			2	664601561	=> 2017	RIEMENSCHLEIBE		PULLEY
8	5			2	664601594	2018 =>	RIEMENSCHLEIBE		PULLEY
8	6	2	2	2	664216048		KUGELLAGER		BEARING
8	7	2	2	2	664610800		SPRENGRING		SNAP RING
8	8	2	2	2	664609200		SICHERUNGSRING		RETAINING RING
8	9	1	1	1	664650037		VERSTÄRKUNG		STIFFENING
8	10	2	2	2	664793102	=> 2017	SCHRAUBE		SCREW
8	10	2	2	2	664691700	2018 =>	SCHRAUBE		SCREW
8	11	2	2	2	664521350		SCHEIBE		WASHER
8	12	2	2	2	664583500		FEDERRING		GROWER
8	13	4	4	4	664600031		DISTANZRING		SPACER
8	14	4	4	4	664038000		BUCHSE		BUSH
8	15	1	1	1	664691700		SCHRAUBE		SCREW
8	16	3	3	3	664691200		SCHRAUBE		SCREW
8	17	4	4	4	664521350		SCHEIBE		WASHER
8	18	4	4	4	664293201	=> 2017	MUTTER		NUT
8	18	4	4	4	664155000	2018 =>	MUTTER		NUT
8	19	1	1	1	664793900		SCHRAUBE		SCREW
8	20	1	1	1	664293200		MUTTER		NUT
8	21	2	2		664601560		RIEMENSCHLEIBE		PULLEY
8	21			2	664601562	=> 2017	RIEMENSCHLEIBE		PULLEY
8	21			2	664601596	2018 =>	RIEMENSCHLEIBE		PULLEY
8	22	3	3	3	664139480		KEIL		KEY
8	23	1	1	1	664793102		SCHRAUBE		SCREW
8	24	1	1	1	664670007		SCHEIBE		WASHER
8	25	1	1	1	664583500		FEDERRING		GROWER
8	26	1	1		664065600		KEILRIEMEN		V-BELT
8	26			1	664065601	=> 2017	KEILRIEMEN		V-BELT
8	26			1	664065606	2018 =>	KEILRIEMEN		V-BELT
8	27	3	3	3	664815200		SCHRAUBE		SCREW
8	28	3	3	3	664292102		MUTTER		NUT
8	29	1	1		664060128		GEHÄUSE	mod. 102	CASE
8	29			1	664060101		GEHÄUSE	mod. 122	CASE
8	30	6	6	6	664735110		SCHRAUBE		SCREW
8	31	1	1		664601550		RIEMENSCHLEIBE		PULLEY
8	31			1	664601549		RIEMENSCHLEIBE		PULLEY
8	32	1	1	1	664793102		SCHRAUBE		SCREW
8	33	1	1	1	664670007		SCHEIBE		WASHER
8	34	1	1	1	664583500		FEDERRING		GROWER
8	35	1	1	1	664160002		DISTANZRING		SPACER
8	36	1	1		664318115		BREMSHEBEL		BRAKE LEVER
8	36			1	664318119		BREMSHEBEL		BRAKE LEVER
8	40	1	1	1	664028523		RIEMENSCHLEIBE		PULLEY
8	41	1	1	1	664028522		DISTANZBUCHSE		SPACER
8	42	1	1	1	664818900		SCHRAUBE		SCREW
8	43	1	1	1	664523060		SCHEIBE		WASHER
8	44	1	1	1	664155000		MUTTER		NUT
8	45	1	1	1	664793102		SCHRAUBE		SCREW
8	46	1	1	1	664523070		SCHEIBE		WASHER
8	47	1	1	1	664583500		FEDERRING		GROWER
8	48	1	1		664062813		KEILRIEMEN		V-BELT
8	48			1	664062812		KEILRIEMEN		V-BELT
8	50	1	1	1	664523060		SCHEIBE		WASHER
8	51	1	1		664028553	=> 2018	SCHUTZ		PROTECTION
8	51	1	1		664031492	2019 =>	SCHUTZ		PROTECTION
8	51			1	664028552	=> 2018	SCHUTZ		PROTECTION
8	51			1	664031491	2019 =>	SCHUTZ		PROTECTION
8	52	1	1		664028555	=> 2018	SCHUTZ		PROTECTION
8	52	1	1		664031494	2019 =>	SCHUTZ		PROTECTION
8	52			1	664028554	=> 2018	SCHUTZ		PROTECTION
8	52			1	664031493	2019 =>	SCHUTZ		PROTECTION
8	53	2	2	2	664028556		HALTER		CLAMP
8	54	2	2	2	664028557		HALTER		CLAMP
8	55	1	1	1	664028558		HALTER		CLAMP
8	56	1	1	1	664028559		HALTER		CLAMP
8	91	1	1		664004608		BOWDENZUG		CONTROL CABLE
8	91			1	664004609		BOWDENZUG		CONTROL CABLE

TM10218H (2015-2019) ,
TM10220H2 (2015-2019) ,
TM12222H2 (2015-2019)

9

Schneidwerkzeug (2)
Cutting plate (2)

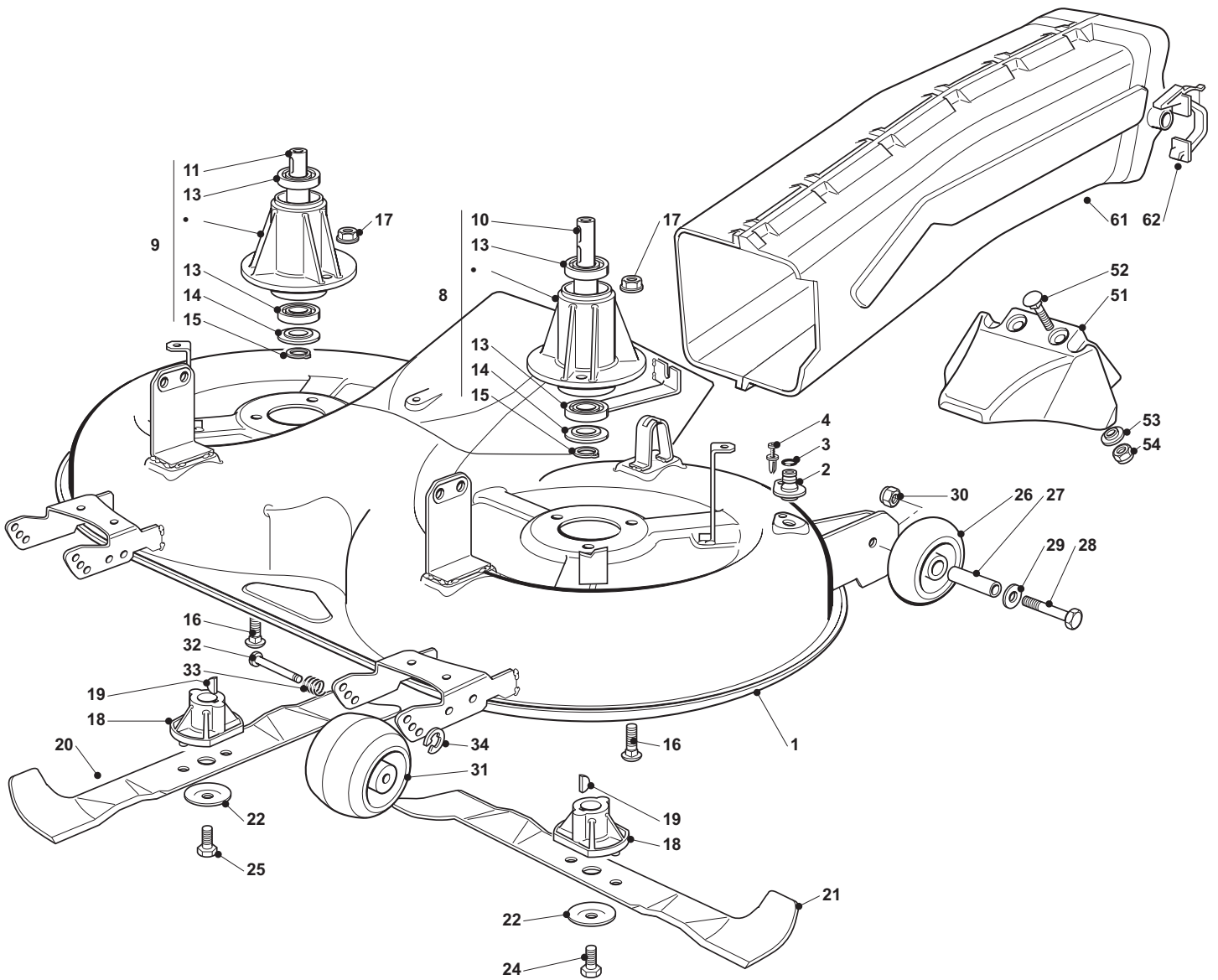

=> 2017



TM10218H (2015-2019) ,
 TM10220H2 (2015-2019) ,
 TM12222H2 (2015-2019)

9

Schneidwerkzeug (2)
 Cutting plate (2)



Seite / Page	Pos.	TM10218H (2015-2019)	TM10220H2 (2015-2019)	Teil-Nr. Part No.	Hinweise Notes	Bezeichnung	Spezifikation Specification	Description
9	1	1	1	664564131		MÄHDECK	102	PLATE
9	2	2	2	664033060		WASSERANSCHLUSS		WATER HOSE CONNECTION
9	3	2	2	664035000		O-RING		O-RING
9	4	2	2	664500030		NIET		RIVET
9	8	1	1	664999200		MESSERWELLE HAUPTSATZ	INC. 10,13-15	MAIN SHAFT SUPPORT
9	9	1	1	664207201		MESSERWELLE ZWEITSATZ	INC. 11,13-15	BLADE SECONDARY SHAFT SUPPORT
9	10	1	1	664020800		MESSERWELLE		SUPPORT
9	11	1	1	664020801		MESSERWELLE		SUPPORT
9	13	4	4	664216047		KUGELLAGER		BALL BEARING
9	14	2	2	664160501		STAUBSCHUTZSCHEIBE		DUST COVER
9	15	2	2	664609260		SICHERUNGSRING		RETAINING RING
9	16	6	6	664818700	=> 2018	SCHRAUBE		SCREW
9	16	6	6	664082516	2019 =>	SCHRAUBE		SCREW
9	17	6	6	664154210		MUTTER		NUT
9	18	2	2	664463200		MESSERHALTER		BLADE HUB
9	19	2	2	664139100		KEIL		KEY
9	20	1	1	664004348		MULCHMESSER RECHTS	102 cm	BLADE (COLLECT AND MULCH) RIGHT
9	20	1	1	664004341		FANGMESSER RECHTS	102 cm	BLADE (COLLECT) RIGHT
9	21	1	1	664004347		MULCHMESSER LINKS	102 cm hydro	BLADE (COLLECT AND MULCH) LEFT
9	21	1	1	664004340		FANGMESSER LINKS	102 cm	BLADE (COLLECT) LEFT
9	22	2	2	664160400	=> 2017	FEDERSCHEIBE		ELASTIC WASHER
9	22	2	2	664160503	2018 =>	FEDERSCHEIBE		ELASTIC WASHER
9	23	2	2	664523080	=> 2017	SCHEIBE		WASHER
9	24	1	1	664735694	=> 2017	SCHRAUBE	R	SCREW
9	24	1	1	664735696	2018 =>	SCHRAUBE		SCREW
9	25	1	1	664735695	=> 2017	SCHRAUBE	L	SCREW
9	25	1	1	664735697	2018 =>	SCHRAUBE		SCREW
9	26	2	2	664700003		SKALPIERSCHUTZRÄDCHEN	Ø 80	ANTI SCALP WHEEL
9	27	2	2	664510072		DISTANZSTÜCK		SPACER
9	28	2	2	664692050		SCHRAUBE	M8x85	SCREW
9	29	2	2	664523060		SCHEIBE		WASHER
9	30	2	2	664293201		MUTTER		NUT
9	31	2	2	664700004		SKALPIERSCHUTZRÄDCHEN	Ø 100	ANTI SCALP WHEEL
9	32	2	2	664510121		BOLZEN		PIN
9	33	2	2	664450115		FEDER		SPRING
9	34	2	2	664000930		SPRENGRING	6	SAFETY WASHER
9	51	1	1	664140100		ABWEISER		DEFLECTOR
9	52	2	2	664815210		SCHRAUBE		SCREW
9	53	2	2	664038002		BUCHSE		BUSH
9	54	2	2	664154510		MUTTER		NUT
9	61	1	1	664108016		AUSWURFKANAL	102	CONVEYOR
9	62	2	2	664774373		HALTER		BRACKET

TM10218H (2015-2019) ,
TM10220H2 (2015-2019) ,
TM12222H2 (2015-2019)

9a

Schneidwerkzeug (2a)
Cutting plate (2a)

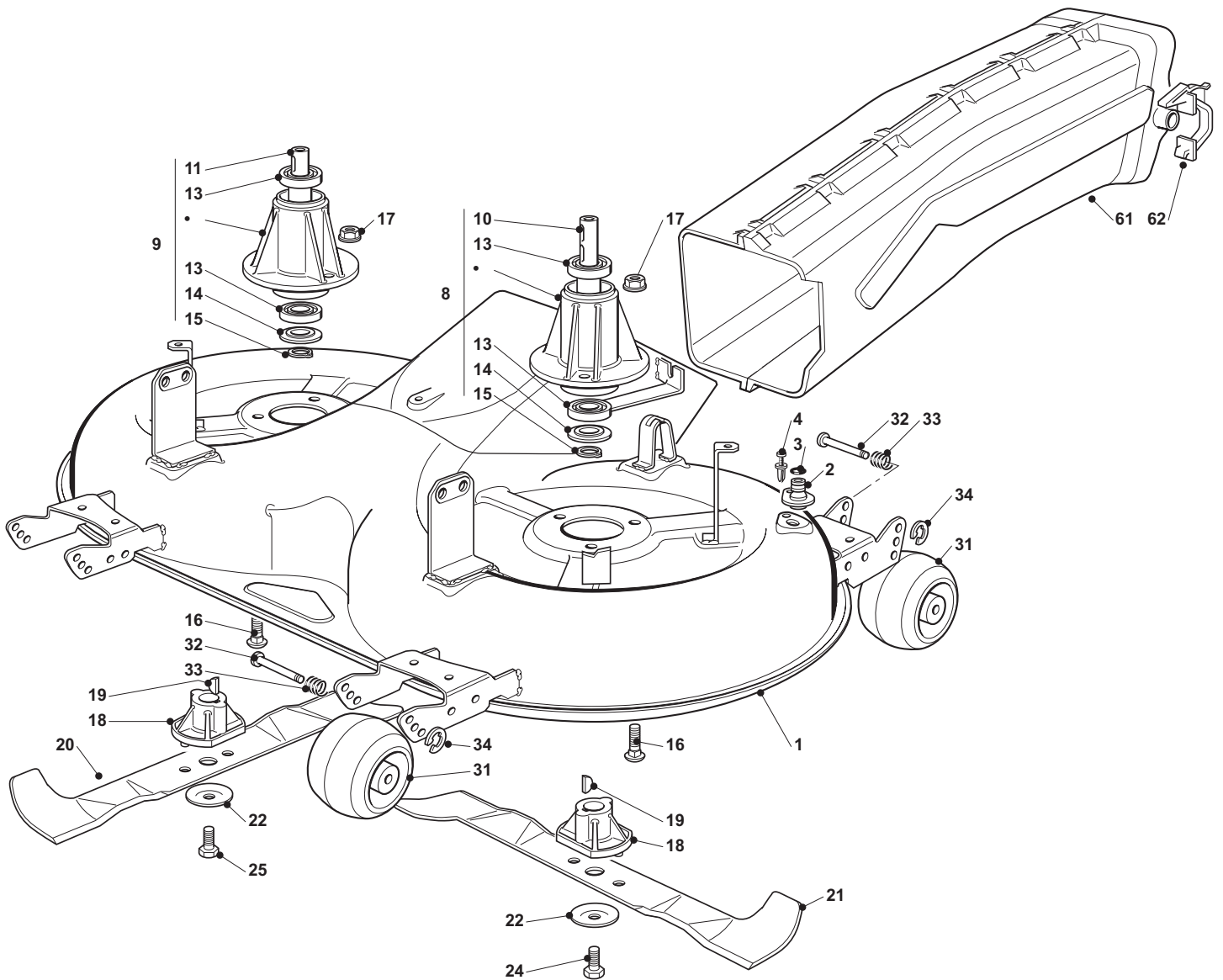

TM10218H (2015-2019) ,
 TM10220H2 (2015-2019) ,
 TM12222H2 (2015-2019)

9a

Schneidwerkzeug (2a)
 Cutting plate (2a)



Seite / Page	Pos.	Teil-Nr. Part No.	Hinweise Notes	Bezeichnung	Spezifikation Specification	Description
9a	1	664564213		MÄHDECK	122, black	PLATE
9a	2	664033060		WASSERANSCHLUSS		WATER HOSE CONNECTION
9a	3	664035000		O-RING		O-RING
9a	4	664500030		NIET		RIVET
9a	8	664999200		MESSERWELLE HAUPTSATZ	INC. 10,13-15	MAIN SHAFT SUPPORT
9a	9	664207201		MESSERWELLE ZWEITSATZ	INC. 11,13-15	BLADE SECONDARY SHAFT SUPPORT
9a	10	664020800		MESSERWELLE		SUPPORT
9a	11	664020801		MESSERWELLE		SUPPORT
9a	13	664216047		KUGELLAGER		BALL BEARING
9a	14	664160501		STAUBSCHUTZSCHEIBE		DUST COVER
9a	15	664609260		SICHERUNGSRING		RETAINING RING
9a	16	664818700	=> 2017	SCHRAUBE		SCREW
9a	16	664082516	2018 =>	SCHRAUBE		SCREW
9a	17	664154210		MUTTER		NUT
9a	18	664463200		MESSERHALTER		BLADE HUB
9a	19	664139100		KEIL		KEY
9a	20	664004350		MULCHMESSER RECHTS	122 cm	BLADE (COLLECT AND MULCH) RIGHT
9a	20	664004343		FANGMESSER RECHTS	122 cm	BLADE (COLLECT) RIGHT
9a	21	664004349		MULCHMESSER LINKS	122 cm	BLADE (COLLECT AND MULCH) LEFT
9a	21	664004342		FANGMESSER LINKS	122 cm	BLADE (COLLECT) LEFT
9a	22	664160400	=> 2017	FEDERSCHEIBE		ELASTIC WASHER
9a	22	664160503	2018 =>	FEDERSCHEIBE		ELASTIC WASHER
9a	23	664523080	=> 2017	SCHEIBE		WASHER
9a	24	664735694	=> 2017	SCHRAUBE	R	SCREW
9a	24	664735696	2018 =>	SCHRAUBE		SCREW
9a	25	664735695	=> 2017	SCHRAUBE	L	SCREW
9a	25	664735697	2018 =>	SCHRAUBE		SCREW
9a	31	664700004		SKALPIERSCHUTZRÄDCHEN	Ø 100	ANTI SCALP WHEEL
9a	32	664510121		BOLZEN		PIN
9a	33	664450115		FEDER		SPRING
9a	34	664000930		SPRENGRING	6	SAFETY WASHER
9a	61	664108020		AUSWURFKANAL	122	CONVEYOR
9a	62	664774373		HALTER		BRACKET

TM10218H (2015-2019) ,
TM10220H2 (2015-2019) ,
TM12222H2 (2015-2019)

10

Grasfangsack
GRASS CATCHER

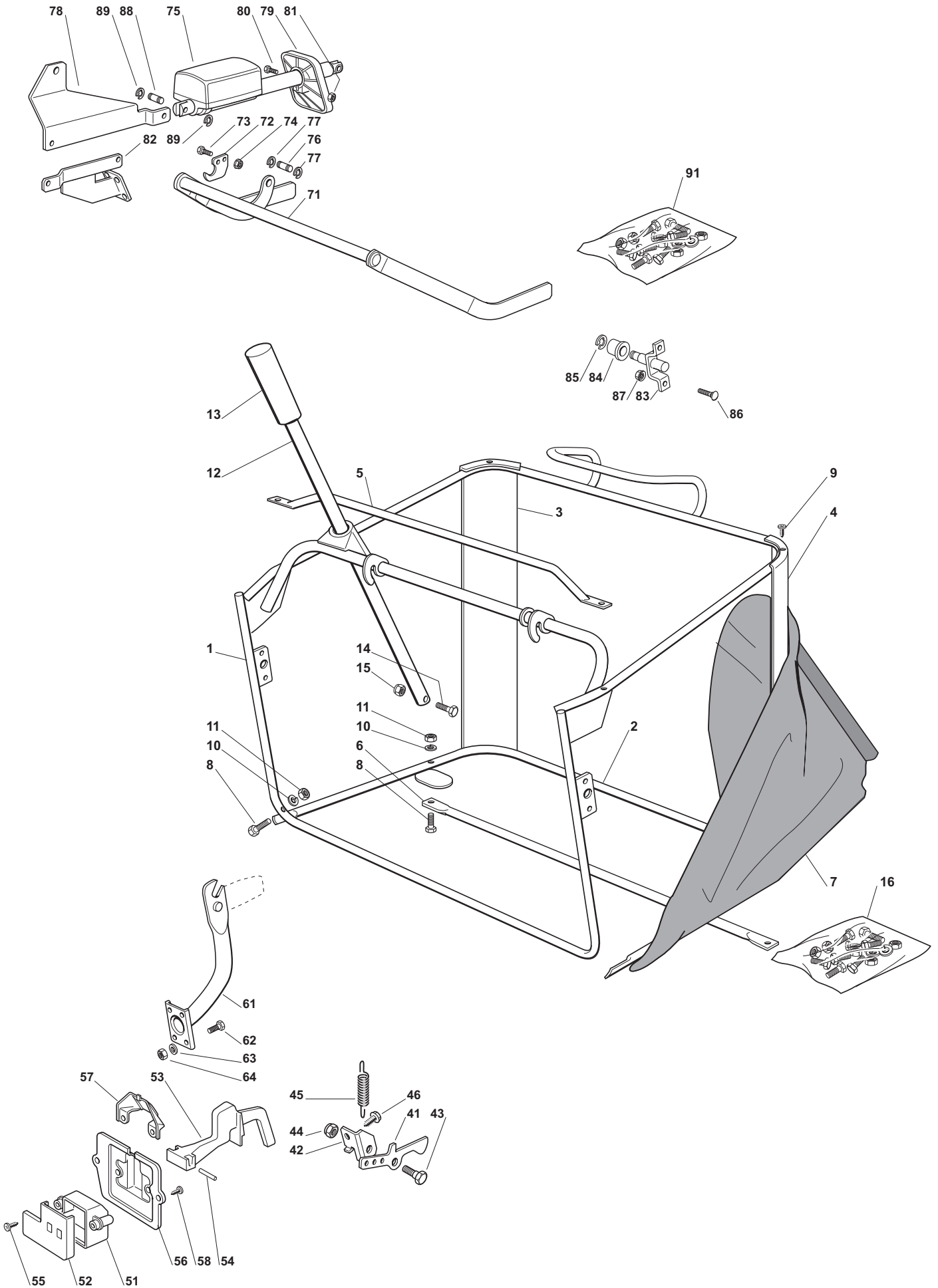

TM10218H (2015-2019) ,
 TM10220H2 (2015-2019) ,
 TM12222H2 (2015-2019)

10

Grasfangsack
 GRASS CATCHER



Seite / Page	Pos.	TM10218H (2015-2019)	TM10220H2 (2015-2019)	TM12222H2 (2015-2019)	Teil-Nr. Part No.	Hinweise Notes	Bezeichnung	Spezifikation Specification	Description
10	1	1	1		664800051		OBERERRAHMEN		UPPER FRAME
10	1			1	664800093		OBERERRAHMEN		UPPER FRAME
10	2	1	1	1	664800002		UNTERERRAHMEN		LOWER FRAME
10	3	1	1	1	664032001		HALTER RECHTS		SUPPORT RIGHT
10	4	1	1	1	664032002		HALTER LINKS		SUPPORT LEFT
10	5	1	1	1	664394001		VORDERGRIFF		HANDLE
10	6	1	1	1	664650038		VERSTÄRKUNG OBEN		STIFFENING LOWER
10	7	1	1	1	664106000		GRASFANGSACK		GRASS CATCHER
10	8	4	4	4	664792099		SCHRAUBE		SCREW
10	9	4	4	4	664729601		SCHRAUBE		SCREW
10	10	4	4	4	664582101		FEDERRING		GROWER
10	11	4	4	4	664292100		MUTTER		NUT
10	12	1	1	1	664869029		STANGE		ROD
10	13	1	1	1	664999508		GRIFF		HANDLE
10	14	1	1	1	664792099		SCHRAUBE		SCREW
10	15	1	1	1	664154510		MUTTER		NUT
10	16	1	1	1	664180027		SCHRAUBENAUSRÜSTUNG		SCREWS OUTFIT
10	41	1	1	1	664774315		HALTER		BRACKET
10	42	1	1	1	664028524		WINKEL		BRACKET
10	43	1	1	1	664510080	=> 2017	BOLZEN		PIN
10	43	1	1	1	664100802	2018 =>	BOLZEN		PIN
10	44	1	1	1	664292102		MUTTER		NUT
10	45	1	1	1	664430210		FEDER		SPRING
10	46	1	1	1	664735122	=> 2017	SCHRAUBE		SCREW
10	46	1	1	1	664028508	2018 =>	SCHRAUBE		SCREW
10	51	1	1	1	664600041		SCHUTZ		PROTECTION
10	52	1	1	1	664600042		SCHUTZDECKEL		PROTECTION COVER
10	53	1	1	1	664318124		HEBEL		LEVER
10	54	1	1	1	664400030		BOLZEN		PIN
10	55	1	1	1	664728510		SCHRAUBE		SCREW
10	56	1	1	1	664785272	=> 2017	SCHUTZ		PROTECTION
10	56	1	1	1	664852721	2018 =>	SCHUTZ		PROTECTION
10	57	1	1	1	664600048		ABWEISERDECKEL		DEFLECTOR COVER
10	58	2	2	2	664728450		SCHRAUBE		SCREW
10	61	2	2		664774225		HALTER		SUPPORT
10	61			2	664774245		HALTER		SUPPORT
10	62	6	6	6	664793102		SCHRAUBE		SCREW
10	63	6	6	6	664523060		SCHEIBE		WASHER
10	64	6	6	6	664293201		MUTTER		NUT
10	71			1	664028560		ACHSE		AXLE
10	72			2	664774317		PLATTE		PLATE
10	73			4	664815210		SCHRAUBE		SCREW
10	74			4	664154510		MUTTER		NUT
10	75			1	664999000		AKTUATOR		ACTUATOR
10	76			1	664510083		BOLZEN		PIN
10	77			2	664999955		SPRENGRING	D=8	SNAP RING
10	78			1	664785197		HALTER		SUPPORT
10	79			1	664600060		SCHUTZ		PROTECTION
10	80			1	664727795		SCHRAUBE		SCREW
10	81			1	664154330		MUTTER		NUT
10	82			1	664650209		VERSTÄRKUNG		STIFFENING
10	83			2	664999147		HALTER		SUPPORT
10	84			2	664690001		WALZE		ROLL
10	85			2	664000956		SPRENGRING		SNAP RING
10	86			4	664818690		SCHRAUBE		SCREW
10	87			4	664293201		MUTTER		NUT
10	88			1	664510083		BOLZEN		PIN
10	89			2	664999955		SPRENGRING	D=8	SNAP RING
10	91			1	664180045		SCHRAUBENAUSRÜSTUNG		SCREWS OUTFIT

TM10218H (2015-2019) ,
TM10220H2 (2015-2019) ,
TM12222H2 (2015-2019)

11b

Elektrische Teile
Electrical parts

Makita

DOLMAR

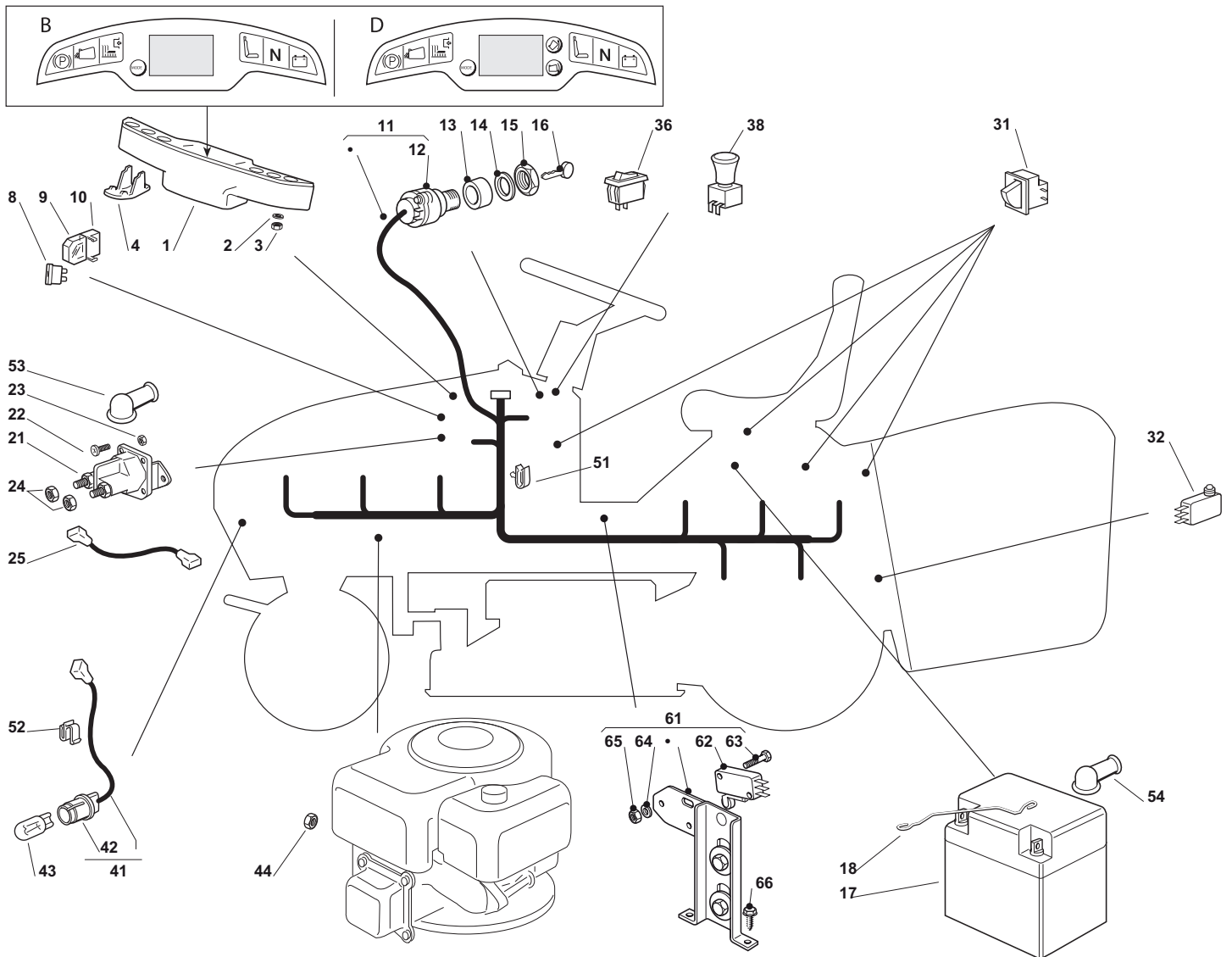

TM10218H (2015-2019) ,
 TM10220H2 (2015-2019) ,
 TM12222H2 (2015-2019)

11b

Elektrische Teile
 Electrical parts



Seite / Page	Pos.	TM10218H (2015-2019)	TM10220H2 (2015-2019)	TM12222H2 (2015-2019)	Teil-Nr. Part No.	Hinweise Notes	Bezeichnung	Spezifikation Specification	Description
11b	1	1	1		664028561	=> 2017	SCHUTZ	B	PROTECTION
11b	1	1	1		664224321	2018 =>	SCHUTZ	B	PROTECTION
11b	1			1	664028562	=> 2017	SCHUTZ	D	PROTECTION
11b	1			1	664224331	2018 =>	SCHUTZ	D	PROTECTION
11b	2	2	2	2	664521320		SCHEIBE		WASHER
11b	3	2	2	2	664154330		MUTTER		NUT
11b	4	1	1	1	664031501		ABWEISER		DEFLECTOR
11b	8	1	1	1	664340040		SICHERUNG	10A	FUSE
11b	8	1	1	1	664340036		SICHERUNG	25A	FUSE
11b	8			1	664340035	=> 2017	SICHERUNG	15A	FUSE
11b	9	2	2	2	664215000		DECKEL		COVER
11b	10	2	2	2	664500007		SICHERUNGHALTER		FUSE CARRIER
11b	11	1	1	1	664028563	=> 2017	KABELSATZ	INC. 12	CABLES
11b	11	1	1	1	664040216	2018 =>	KABELSATZ	INC. 12	CABLES
11b	12	1	1	1	664450072		SCHALTER		STARTING SWITCH
11b	13	1	1	1	664550136		DISTANZRING		SPACER
11b	14	1	1	1	664550135		SCHEIBE		WASHER
11b	15	1	1	1	664400862		NUTMUTTER		RING NUT
11b	16	1	1	1	664210022		SCHLÜSSEL FÜR START		STARTING KEY
11b	17	1	1	1	664120002		BATTERIE		BATTERY
11b	18	1	1	1	664430230		FEDER		SPRING
11b	21	1	1	1	664736110	=> 2017	ANLASSRELAIS		STARTER RELAY
11b	21	1	1	1	664736113	2018 =>	ANLASSRELAIS		STARTER RELAY
11b	22	2	2	2	664791011		SCHRAUBE		SCREW
11b	23	2	2	2	664292102		MUTTER		NUT
11b	24	2	2	2	664360352		MUTTER		NUT
11b	25	1	1	1	664065017		KABEL		CABLE
11b	31	4	4	3	664410613		MIKROSCHALTER		MICRO SWITCH
11b	32	1	1	1	664410605		FÜLLHÖHENSCHALTER		FULL GRASS CATCHER MICRO
11b	36	1	1	1	664450060	=> 2017	LICHTSCHALTER		SWITCH
11b	36	1	1	1	664500601	2018 =>	LICHTSCHALTER		FARILAMP SWITCH
11b	38			1	664028565		KUPPLUNGSSCHALTER		CLUTCH SWITCH
11b	41	1	1	1	664040073		KABEL	DELI TIRE INC. 42	CABLE
11b	42	2	2	2	664999030		LAMPENFASSUNG		LAMP SOCKET
11b	43	2	2	2	664459100		LAMPE HALOGEN		LAMP, HALOGEN
11b	44	1	1	1	664361005		MUTTER		NUT
11b	51	5	5	5	664320506		KABELBEFESTIGUNG		FAIRLEAD
11b	52	1	1	1	664320504		KABELBEFESTIGUNG		FAIRLEAD
11b	53	1	1	1	664564861	=> 2017	STECKER		PROTECTION
11b	53	1	1	1	664648612	2018 =>	STECKER		PROTECTION
11b	54	1	1	1	664564864		STECKER		CONNECTOR
11b	61	1	1	1	664394853	=> 2017	MIKROSCHALTER SATZ	HYDRO INC. 62-65	MICRO SWITCH SET
11b	61	1	1	1	664948530	2018 =>	MIKROSCHALTER-SET	HYDRO INC. 62-65	MICRO SWITCH SET
11b	62	1	1	1	664410609		MIKROSCHALTER LEERLAUF		SWITCH
11b	63	2	2	2	664735602		SCHRAUBE		SCREW
11b	64	2	2	2	664581100		FEDERRING		SPRING RING
11b	65	2	2	2	664290791		MUTTER		NUT
11b	66	2	2	2	664735110		SCHRAUBE		SCREW

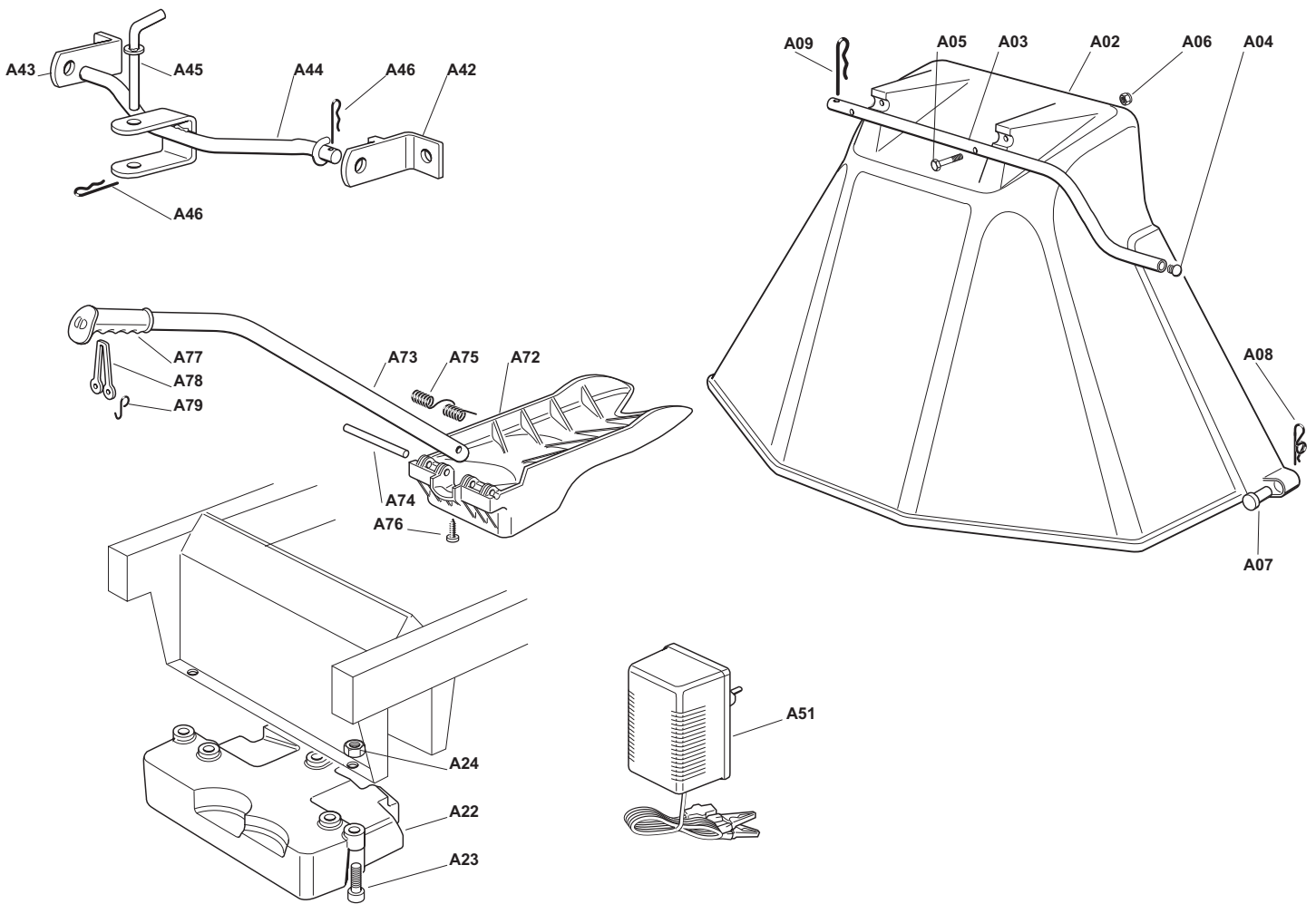

TM10218H (2015-2019) ,
 TM10220H2 (2015-2019) ,
 TM12222H2 (2015-2019)

12

Zubehör nach Anfrage
 Optionals on request



Seite / Page	Pos.	TM10218H (2015-2019)	TM10220H2 (2015-2019)	TM12222H2 (2015-2019)	Teil-Nr. Part No.	Hinweise Notes	Bezeichnung	Spezifikation Specification	Description
12	A02	1	1	1	664400003		AUSWURFSCHUTZ		EJECTION GUARD
12	A03	1	1	1	664869043		HALTER		SUPPORT
12	A04	2	2	2	664566110		PFROPFEN		CAP
12	A05	2	2	2	664689515		SCHRAUBE		SCREW
12	A06	2	2	2	664154510		MUTTER		NUT
12	A07	2	2	2	664510022		BOLZEN		PIN
12	A08	2	2	2	664487998		SPLINT		COTTER PIN
12	A09	1	1	1	664487999		SPLINT		COTTER PIN
12	A22	1	1	1	664519997		FRONTGEWICHT	72-92-102-122	FRONT WEIGHT
12	A23	3	3	3	664760520		SCHRAUBE		SCREW
12	A24	3	3	3	664155000		MUTTER		NUT
12	A42	1	1	1	664735502		BUEGELHALTER RECHTS		BRACKET RIGHT
12	A43	1	1	1	664774213		BUEGELHALTER LINKS		BRACKET LEFT
12	A44	1	1	1	664033105		STANGE		ROD
12	A45	1	1	1	664510021		BOLZEN		PIN
12	A46	2	2	2	664487999		SPLINT		COTTER PIN
12	A51	1	1	1	664180050		LADEGERÄT	EU (SCHUKO)	BATTERY CHARGER
12	A51	1	1	1	664180091		LADEGERÄT	U.K.	BATTERY CHARGER
12	A72	1	1	1	664140097		ABWEISER	mod. 102	DEFLECTOR
12	A72			1	664140092		ABWEISER	mod. 122	DEFLECTOR
12	A73	1	1	1	664394005		STIEL		HANDLE
12	A74	1	1	1	664510077		BOLZEN		PIN
12	A74			1	664510074		BOLZEN		PIN
12	A75	1	1	1	664430245		FEDER		SPRING
12	A75			1	664430240		FEDER		SPRING
12	A76	1	1	1	664735405		SCHRAUBE		SCREW
12	A76			1	664728680		SCHRAUBE		SCREW
12	A77	1	1	1	664280000		GRIFF		HANDGRIP
12	A78	1	1	1	664840011		GUMMIZUG		ELASTIC TIE-ROD
12	A79	2	2	2	664253004		HAKEN		HOOK

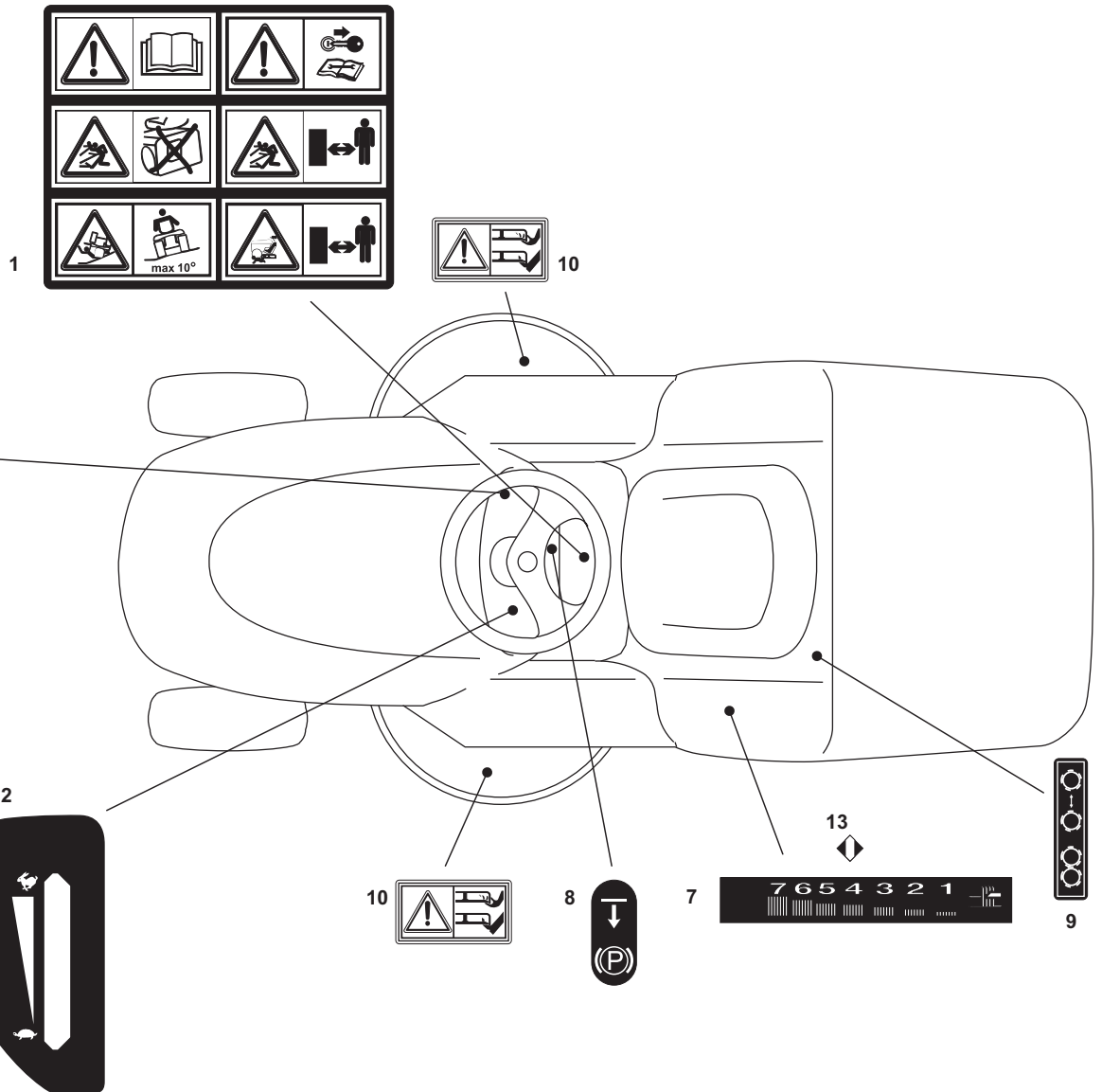

TM10218H (2015-2019) ,
 TM10220H2 (2015-2019) ,
 TM12222H2 (2015-2019)

13

Aufkleber
 Labels



Seite / Page	Pos.	TM10218H (2015-2019)	TM10220H2 (2015-2019)	TM12222H2 (2015-2019)	Teil-Nr. Part No.	Hinweise Notes	Bezeichnung	Spezifikation Specification	Description
13	1	1	1	1	664357428		SCHILD SICHERHEITSHINWEISE		LABEL, SAFETY INSTRUCTIONS
13	2		1	1	664356756		SCHILD, MOTORFERNBEDIENUNG		LABEL, THROTTLE
13	7	1	1	1	664357905		SCHILD, SCHNITTHÖHENVERSTELLUNG		LABEL, HEIGHT ADJUSTMENT
13	8	1	1	1	664998526		SCHILD, PARKBREMSE		LABEL, PARKING BRAKE
13	9	1	1	1	664999423		SCHILD	hydro	LABEL
13	10	2	2	2	664356699		SCHILD SICHERHEITSHINWEISE		LABEL, SAFETY INSTRUCTIONS
13	11	1			664356754		SCHILD, MOTORFERNBEDIENUNG		LABEL, THROTTLE
13	13	1	1	1	664357913		SCHILD		LABEL
13	19	1	1	1	664360912		SCHILD, MESSERKUPPLUNG		LABEL, KNIFE COUPLING

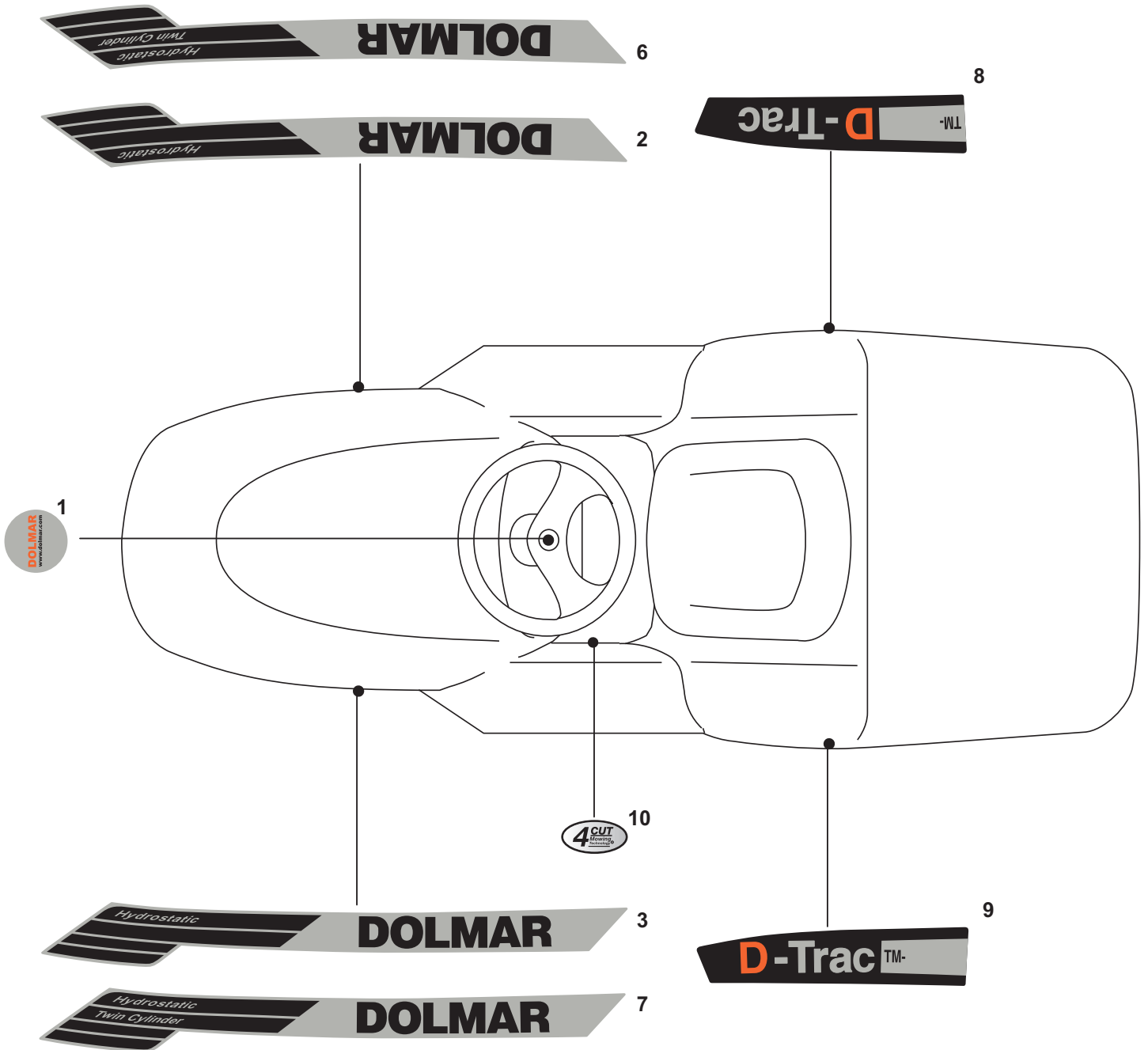

TM10218H (2015-2019) ,
 TM10220H2 (2015-2019) ,
 TM12222H2 (2015-2019)

14

Aufkleber
 Labels



Seite / Page	Pos.	TM10218H (2015-2019)	TM10220H2 (2015-2019)	TM12222H2 (2015-2019)	Teil-Nr. Part No.	Hinweise Notes	Bezeichnung	Spezifikation Specification	Description
14	1	1	1	1	664361485		SCHILD	DOLMAR	LABEL
14	2	1			664362510		SCHILD	DOLMAR	LABEL
14	3	1			664362511		SCHILD	DOLMAR	LABEL
14	6		1	1	664362512		SCHILD	DOLMAR	LABEL
14	7		1	1	664362513		SCHILD	DOLMAR	LABEL
14	8	1			664362524		SCHILD	TM-102.18 H	LABEL
14	8		1		664362522		SCHILD	TM-102.20 H2	LABEL
14	8			1	664362520		SCHILD	TM-122.22 H2	LABEL
14	9	1			664362525		SCHILD	TM-102.18 H	LABEL
14	9		1		664362523		SCHILD	TM-102.20 H2	LABEL
14	9			1	664362521		SCHILD	TM-122.22 H2	LABEL
14	10	1	1	1	664999576		SCHILD	4 CUT	LABEL

- | | |
|--|---|
| <p>1 Rahmensatz
Chassis</p> <p>1 Rahmensatz
Chassis</p> <p>2 Karrosserie
Body</p> <p>3 Lenkgetriebe
Steering</p> <p>4y Pedale für TUFF TORQ Getriebe
Drive and brake controls (TUFF TORQ)</p> <p>4ya Pedale für HYDRO Getriebe
Drive and brake controls (HYDRO)</p> <p>5a Motor
Motor</p> <p>5b Motor
Motor</p> <p>6y Getriebe TUFF TORQ
Gear TUFF TORQ</p> <p>6ya Getriebe HYDRO
Gear HYDRO</p> <p>7 Scheidwerkzeug Aufhebesatz
Cutting plate lifting</p> <p>7 Schneidwerkzeug Aufhebesatz
Cutting plate lifting</p> <p>8 Schneidwerkzeug (1)
Cutting plate (1)</p> <p>9 Schneidwerkzeug (2)
Cutting plate (2)</p> <p>9a Schneidwerkzeug (2a)
Cutting plate (2a)</p> <p>10 Grasfangsack
GRASS CATCHER</p> <p>11b Elektrische Teile
Electrical parts</p> <p>12 Zubehör nach Anfrage
Optionals on request</p> | <p>13 Aufkleber
Labels</p> <p>14 Aufkleber
Labels</p> |
|--|---|

	Zeichenerklärung	Key to symbols
<p>=> 1999999 2000000 => 2003.04 => TI 2003/07 Acc. = { m Corr.</p>	<p>Produktion bis Serien-Nr. Neues Teil ab Serien-Nr. Neues Teil ab Jahr / Monat Siehe Technische Information Jahr / Nr. Zubehör (nicht im Lieferumfang) Keine Serienausführung, jedoch verwendbar Beinhaltet Positions-Nr. Meterware Druckfehlerberichtigung</p>	<p>Production to serial number New part from serial number New part from Year / Month See Technical Information Year / No. Accessories (not included in the delivery inventory) No standard execution, may be used Contains item number Sold by the meter Error correction</p>
	Änderungen vorbehalten	Specifications subject to change without notice