



Ersatzteilliste
Spare Parts List

2018-07

RM7213H (2015-2018)

RM7213H (D, GB)

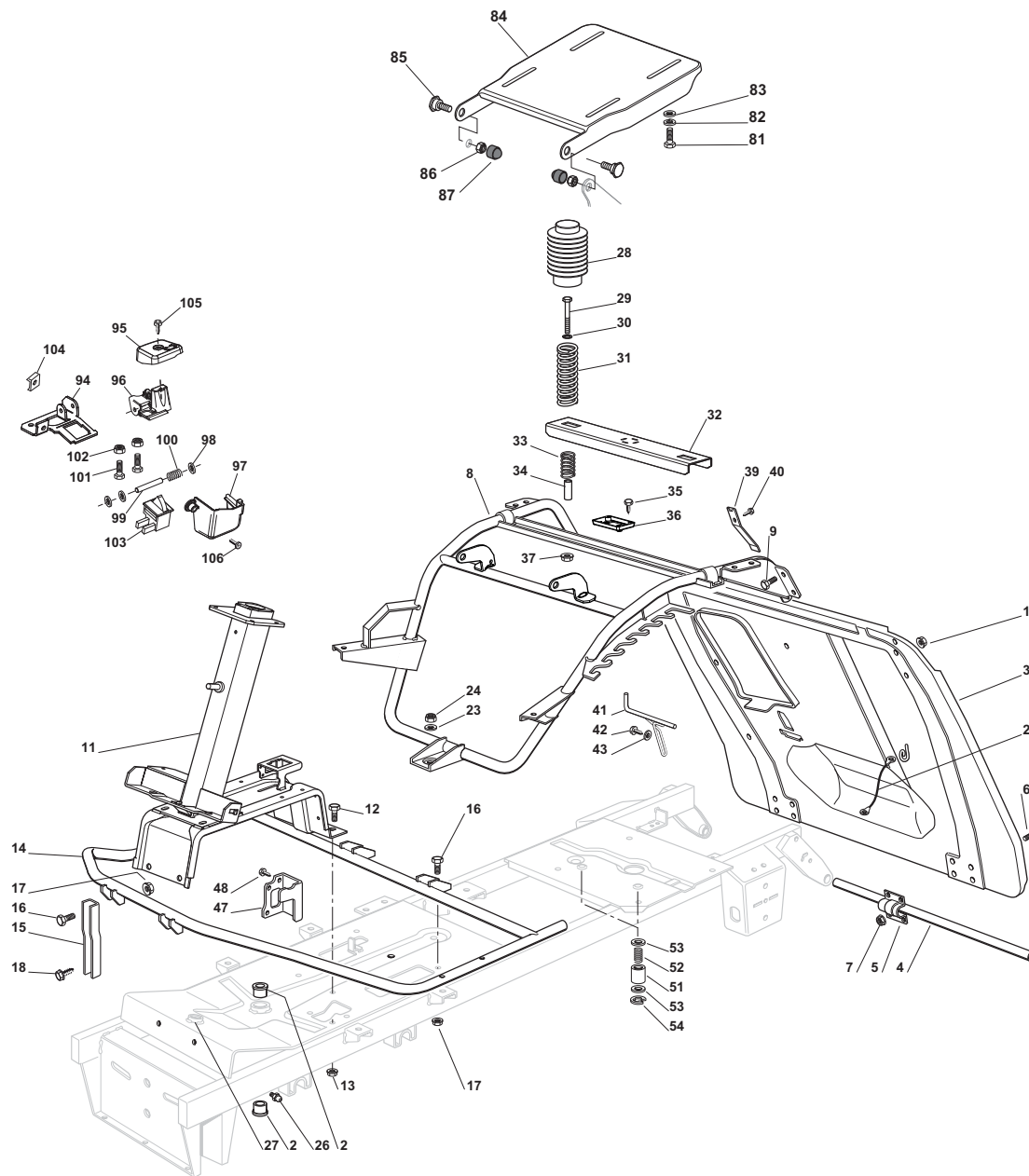

Seite / Page	Pos.	Teil-Nr. Part No.	Hinweise Notes	Bezeichnung	Spezifikation Specification	Description
1	2	2	664034002	BUCHSE		BUSH
1	3	1	664545057	PLATTE		PLATE
1	4	1	664037000	BOLZEN		PIN
1	5	2	664547012	PLATTE		PLATE
1	6	8	664791213	SCHRAUBE		SCREW
1	7	8	664292102	MUTTER		NUT
1	8	1	664801149	RAHMENSATZ		CHASSIS
1	9	4	664792611	SCHRAUBE		SCREW
1	10	4	664293201	MUTTER		NUT
1	11	1	664852430	HALTER		SUPPORT
1	12	4	664792611	SCHRAUBE		SCREW
1	13	4	664293201	MUTTER		NUT
1	14	1	664028472	FUSSBRETTHALTER		FOOTBOARD SUPPORT
1	15	2	664787025	HALTER		SUPPORT
1	16	4	664792611	SCHRAUBE		SCREW
1	17	4	664293201	MUTTER		NUT
1	18	2	664735120	SCHRAUBE		SCREW
1	20	1	664040300	SEIL		CORD
1	23	1	664523060	SCHEIBE		WASHER
1	24	1	664155000	MUTTER		NUT
1	26	1	664379511	FETTBUCHSE		GREASE DISPENSER
1	27	1	664034001	BUCHSE		BUSH
1	28	2	664122003	SCHUTZKASTEN		HOOD
1	29	2	664691400	SCHRAUBE		SCREW
1	30	2	664521350	SCHEIBE		WASHER
1	31	2	664430596	FEDER		SPRING
1	32	1	664543047	PLATTE		PLATE
1	33	2	664430263	FEDER		SPRING
1	34	2	664160048	DISTANZRING		DISTANCE RING
1	35	2	664728686	SCHRAUBE		SCREW
1	36	1	664028473	SCHALTERAUFNAHME		SWITCH PLATE
1	37	2	664293201	MUTTER		NUT
1	39	1	664028474	FEDER		SPRING
1	40	1	664735110	SCHRAUBE		SCREW
1	41	1	664294001	FÜHRUNG		GUIDE
1	42	1	664735120	SCHRAUBE		SCREW
1	43	1	664523040	SCHEIBE		WASHER
1	47	1	664772095	HALTER		CLAMP
1	48	2	664735105	SCHRAUBE		SCREW
1	51	2	664047012	BUCHSE		BUSH
1	52	2	664430577	FEDER		SPRING
1	53	4	664670008	SCHEIBE		WASHER
1	54	2	664999955	SPRENGRING		SNAP RING
1	81	4	664793102	SCHRAUBE		SCREW
1	82	4	664583500	FEDERRING		GROWER
1	83	4	664523060	SCHEIBE		WASHER
1	84	1	664547061	PLATTE		PLATE
1	85	2	664524970	BOLZEN		PIN
1	86	2	664155010	MUTTER		NUT
1	87	2	664203854	ABDECKKAPPE		PROTECTION

RM7213H (2015-2018)

1

RAHMENSATZ
CHASSIS

Seite / Page	Pos.	Teil-Nr. Part No.	Hinweise Notes	Bezeichnung	Spezifikation Specification	Description
1	94	664028475		BÜGEL		BRACKET
1	95	664028476		DECKEL		COVER
1	96	664028477		HALTER		SUPPORT
1	97	664028478		SCHUTZABDECKUNG		GUARD
1	98	664604896		SICHERUNGSSCHEIBE		SAFETY WASHER
1	99	664028479		BOLZEN		PIN
1	100	664028480		FEDER		SPRING
1	101	664791213		SCHRAUBE		SCREW
1	102	664292102		MÜTTER		NUT
1	103	664410613		MIKROSCHALTER		MICRO SWITCH
1	104	664437503		PLATTE		PLATE
1	105	664728686		SCHRAUBE		SCREW
1	106	664028481		SCHRAUBE		SCREW

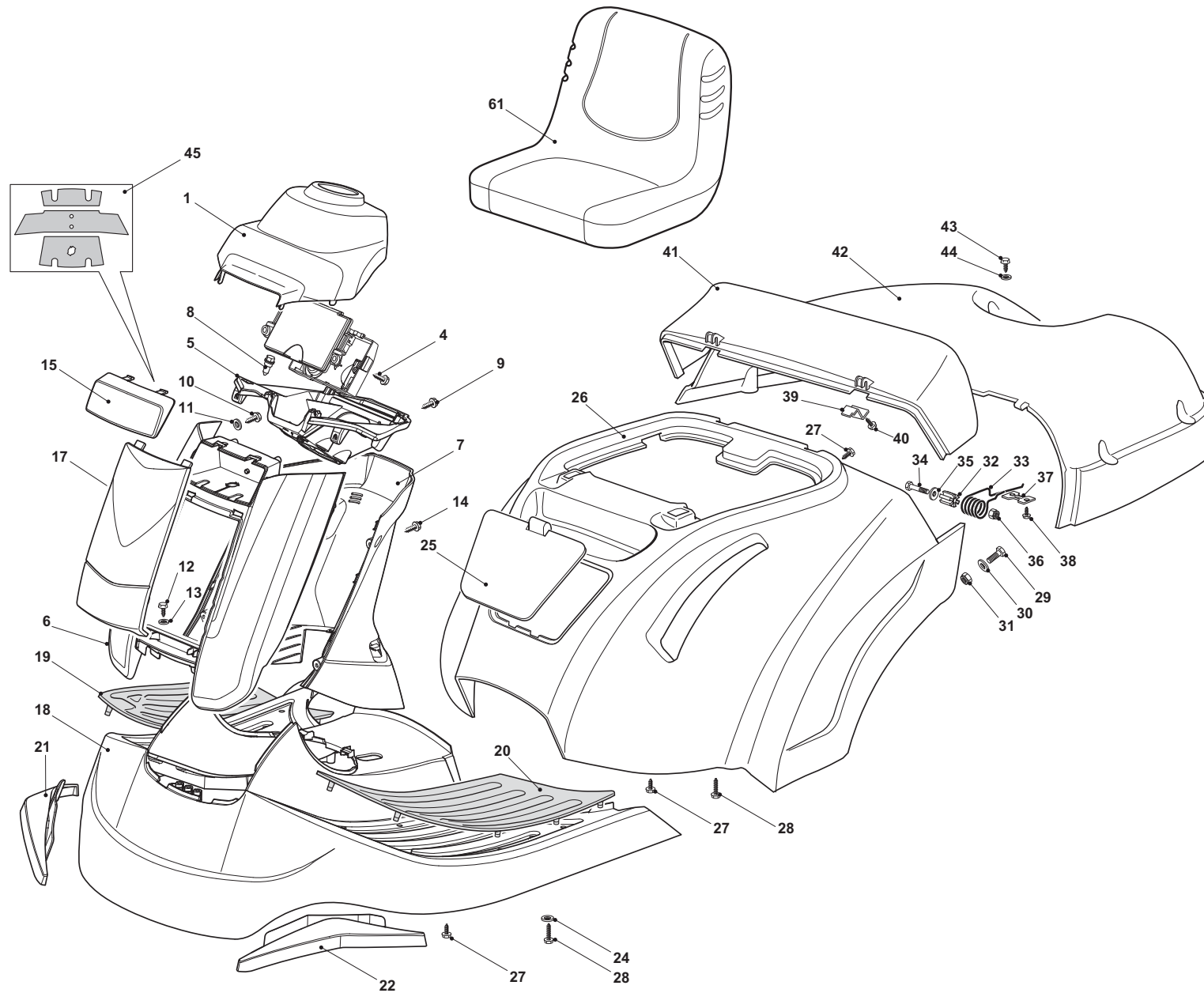



Seite / Page	Pos.	Teil-Nr. Part No.	Hinweise Notes	Bezeichnung	Spezifikation Specification	Description
2	1	664028482		ABDECKUNG		COVER
2	4	664735403		SCHRAUBE		SCREW
2	5	664787084		KONSOLE		DASHBOARD
2	6	664787102		LENKSÄULE SCHUTZ, ROT		STEERING COLUMN PROTECTION, RED
2	7	664787101		HINTERDECKEL ROT		REAR COVER, RED
2	8	664943010		SCHRAUBE		SCREW
2	9	664735403		SCHRAUBE		SCREW
2	10	664735403		SCHRAUBE		SCREW
2	11	664521331		LAGERBUCHSE		BUSHING
2	12	664735410		SCHRAUBE		SCREW
2	13	664521331		LAGERBUCHSE		BUSHING
2	14	664735403		SCHRAUBE		SCREW
2	15	664410913		SCHUTZABDECKUNG		PROTECTION COVER
2	17	664110475		VORDERDECKEL, SCHWARZ		FRONT COVER, BLACK
2	18	664028483		FUSSBRETT ROT		FOOTBOARD, RED
2	19	664110314		FUSSBRETTDECKEL RECHTS		RIGHT FOOTBOARD COVER
2	20	664028484		FUSSBRETTDECKEL LINKS		LEFT FOOTBOARD COVER
2	21	664110502		RADABDECKUNG RECHTS		COVER RIGHT
2	22	664110501		RADABDECKUNG LINKS		COVER LEFT
2	24	664523040		SCHEIBE		WASHER
2	25	664109515		DECKEL ROT		FRONT COVER
2	26	664028485		RADABDECKUNG, ROT	Hydro	COVER, RED
2	27	664735403	=> 2017	SCHRAUBE		SCREW
2	27	664735406	2018 =>	SCHRAUBE		SCREW
2	28	664735410		SCHRAUBE		SCREW
2	29	664791213		SCHRAUBE		SCREW
2	30	664523040		SCHEIBE		WASHER
2	31	664154510		MÜTTER		NUT
2	32	664047003		BUCHSE		BUSH
2	33	664430551		FEDER		SPRING
2	34	664691200		SCHRAUBE		SCREW
2	35	664523070		SCHEIBE		WASHER
2	36	664155000		MÜTTER		NUT
2	37	664546001		PLATTE		PLATE
2	38	664735403	=> 2017	SCHRAUBE		SCREW
2	38	664735406	2018 =>	SCHRAUBE		SCREW
2	39	664546003		PLATTE		PLATE
2	40	664735403	=> 2017	SCHRAUBE		SCREW
2	40	664735406	2018 =>	SCHRAUBE		SCREW
2	41	664110353		HAUBE ROT		GRASS-CATCHER COVER
2	42	664110354		HAUBE ROT		GRASS-CATCHER COVER
2	43	664729601		SCHRAUBE		SCREW
2	44	664521331		LAGERBUCHSE		BUSHING
2	45	664366202		SCHILD SCHEINWERFER		LABEL HEAD LAMP
2	61	664722463		SITZ		SEAT

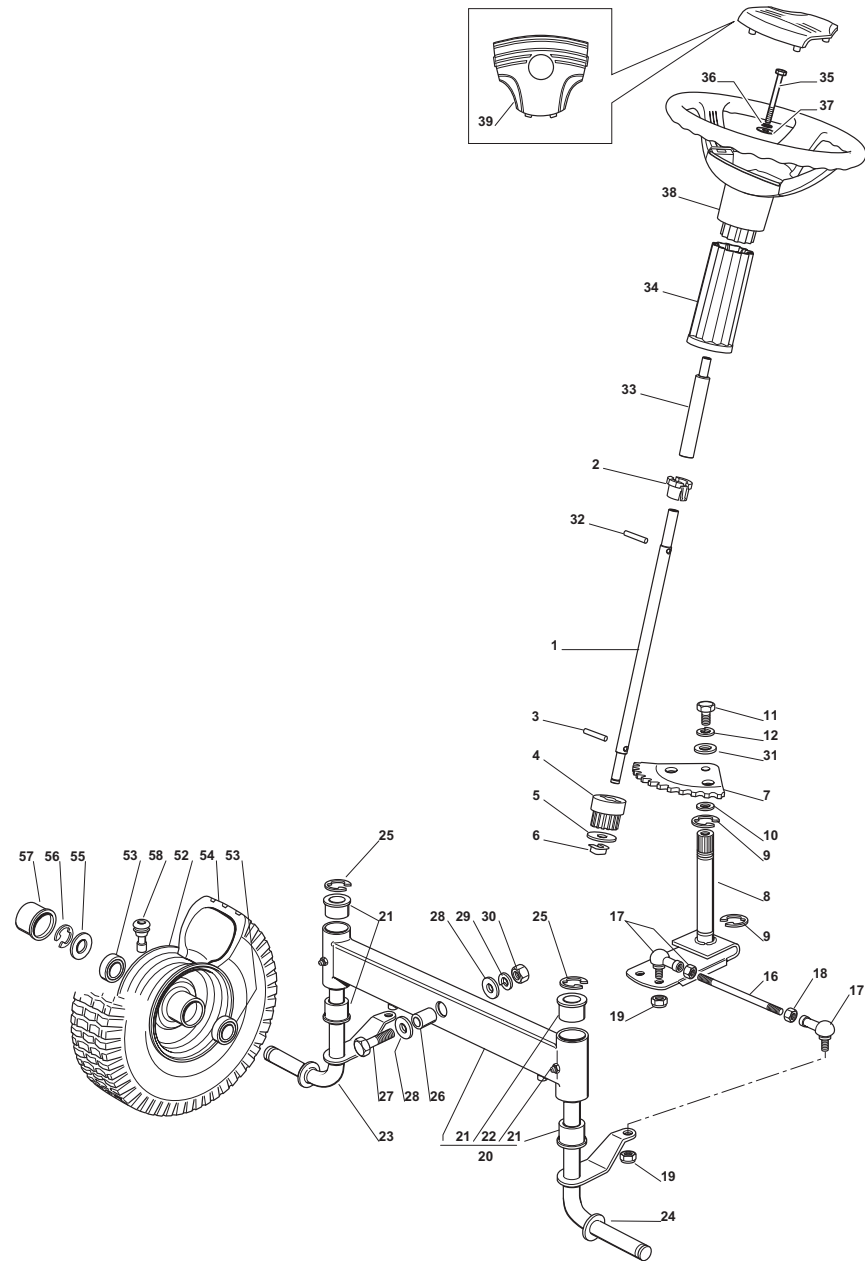

Seite / Page	Pos.	Teil-Nr. Part No.	Hinweise Notes	Bezeichnung	Spezifikation Specification	Description
3	1	664520053		LENKSÄULE		STEERING COLUMN
3	2	664038004		BUCHSE		BUSH
3	3	664622650		STIFT		PIN
3	4	664570050		RITZEL		PINION
3	5	664521370		SCHEIBE		WASHER
3	6	664436030		PLÄTTCHEN		PLATE
3	7	664735551		LENKWELLE		STEERING SHAFT
3	8	664999501		WELLE		SHAFT
3	9	664001000		SPRENGRING		SNAP RING
3	10	664520031		SCHEIBE		WASHER
3	11	664793102		SCHRAUBE		SCREW
3	12	664583500		FEDERRING		GROWER
3	16	664840050		SPANNSTANGE		TIE ROD
3	17	664746609		GELENK		JOINT
3	18	664295201		MUTTER		NUT
3	19	664156602		MUTTER		NUT
3	20	664034057		KIPPEBEL	INC. 21,22	EQUALIZER
3	21	664034002		BUCHSE		BUSH
3	22	664379511		FETTBUCHSE		GREASE DISPENSER
3	23	664230401		ACHSSCHENKEL RECHTS		STUB AXLE RIGHT
3	24	664230403		ACHSSCHENKEL LINKS		STUB AXLE LEFT
3	25	664001000		SPRENGRING		SNAP RING
3	26	664160016	=> 2017	DISTANZRING		SPACER
3	26	664600161	2018 =>	DISTANZRING		SPACER
3	27	664692695		SCHRAUBE		SCREW
3	28	664523100		SCHEIBE		WASHER
3	29	664587100		FEDERRING		GROWER
3	30	664295300		MUTTER		NUT
3	31	664521350		SCHEIBE		WASHER
3	32	664620300		STIFT		PIN
3	33	664160060		DISTANZHÜLSE		SPACER
3	34	664785419		HALTER		SUPPORT
3	35	664840055		SCHRAUBE		SCREW
3	36	664540260		SCHEIBE		WASHER
3	37	664523070		SCHEIBE		WASHER
3	38	664961220		LENKRAD		STEERING WHEEL
3	39	664580503		ABDECKUNG		COVER
3	52	664044007		FELGE		RIMM
3	53	664122210		LAGER		BEARING
3	54	664590067		REIFEN		TYRE
3	55	664670005		SCHEIBE		WASHER
3	56	664001000		SPRENGRING		SNAP RING
3	57	664110230		NABENDECKEL		HUB COVER
3	58	664950000		VENTIL		VALVE

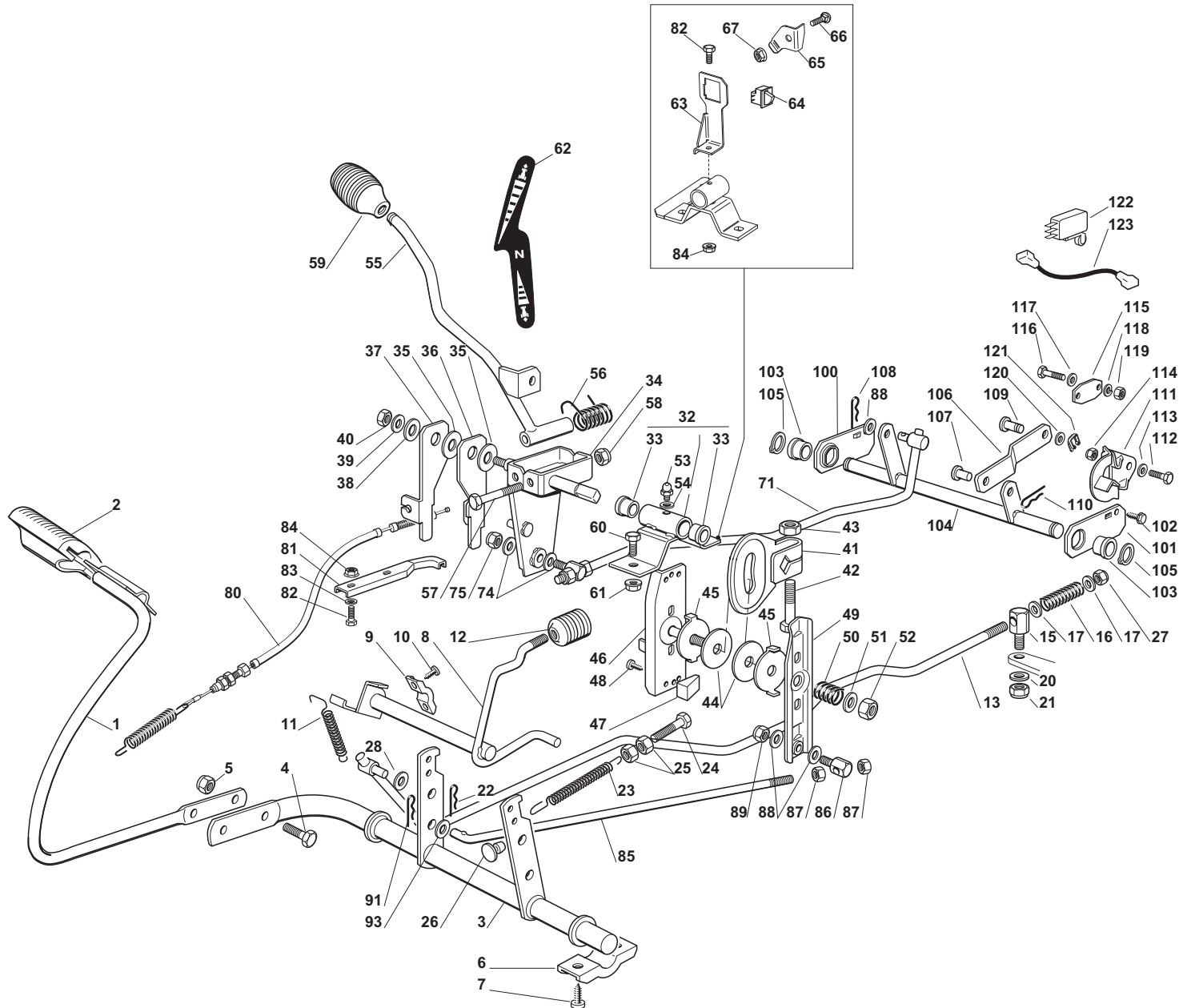

RM7213H (2015-2018)

4y

GETRIEBE UND BREMSE ANTRIEB
DRIVE AND BRAKE CONTROLS

Seite / Page	Pos.	Teil-Nr. Part No.	Hinweise Notes	Bezeichnung	Spezifikation Specification	Description
4y	1	664503001		PEDAL		PEDAL
4y	2	664110267		PEDALGUMMI		PEDAL PAD
4y	3	664001015		ACHSE		AXLE
4y	4	664793301		SCHRAUBE		SCREW
4y	5	664155000		MUTTER		NUT
4y	6	664546015		PLATTE		PLATE
4y	7	664731350		SCHRAUBE		SCREW
4y	8	664001011		ACHSE		AXLE
4y	9	664547049		PLATTE		PLATE
4y	10	664731601		SCHRAUBE		SCREW
4y	11	664430552		FEDER		SPRING
4y	12	664395050		KNOPF		KNOB
4y	13	664002088		STANGE		ROD
4y	15	664295200		MUTTER		NUT
4y	16	664430588		FEDER		SPRING
4y	17	664521360		SCHEIBE		WASHER
4y	20	664523050		SCHEIBE		WASHER
4y	21	664155000		MUTTER		NUT
4y	22	664487997		SPLINT		COTTER PIN
4y	23	664430210		FEDER		SPRING
4y	24	664943005		SCHRAUBE		SCREW
4y	25	664293200		MUTTER		NUT
4y	26	664275000		GUMMI		GROMMET
4y	27	664156602		MUTTER		NUT
4y	28	664670011		SCHEIBE		WASHER
4y	32	664028486		LAGERAUFNAHME MIT BUCHSEN	INC. 33	BRACKET WITH BUSHING
4y	33	664521331	=> 2017	LAGERBUCHSE		BUSHING
4y	33	664045080	2018 =>	LAGERBUCHSE		BEARING
4y	34	664773561		HEBEL		LEVER
4y	35	664672151		SCHEIBE		WASHER
4y	36	664772101		HEBEL LINKS		LEVER LEFT
4y	37	664772103		HEBEL RECHTS		LEVER RIGHT
4y	38	664672152		SCHEIBE		WASHER
4y	39	664523060		SCHEIBE		WASHER
4y	40	664155010		MUTTER		NUT
4y	41	664734055		SEKTOR		SECTOR
4y	42	664794900		SCHRAUBE		SCREW
4y	43	664155020		MUTTER		NUT
4y	44	664158000		SCHEIBE		WASHER
4y	45	664670053		SCHEIBE		WASHER
4y	46	664773565		ZUGPLATTE		CLAMP
4y	47	664063020		NOCKEN		CAM
4y	48	664735110		SCHRAUBE		SCREW
4y	49	664773563		HEBEL		LEVER
4y	50	664430560		FEDER		SPRING
4y	51	664670008		SCHEIBE		WASHER
4y	52	664155020		MUTTER		NUT
4y	53	664379511		FETTBUCHSE		GREASE DISPENSER
4y	54	664521331		LAGERBUCHSE		BUSHING
4y	55	664317101		HEBEL		LEVER

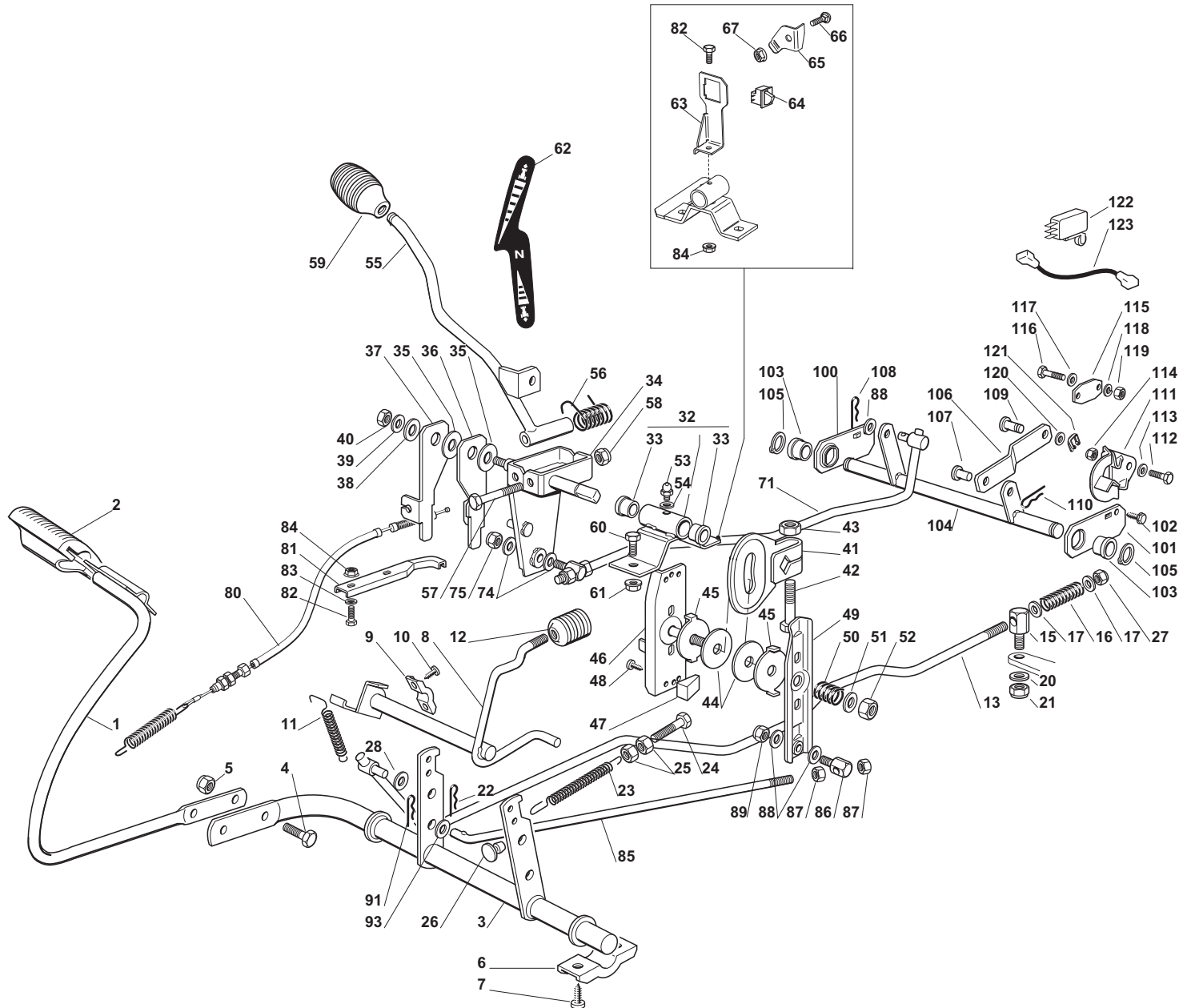

RM7213H (2015-2018)

4y

GETRIEBE UND BREMSE ANTRIEB
DRIVE AND BRAKE CONTROLS

Seite / Page	Pos.	Teil-Nr. Part No.	Hinweise Notes	Bezeichnung	Spezifikation Specification	Description
4y	56	1 664430226		FEDER		SPRING
4y	57	1 664692050		SCHRAUBE	M8x85	SCREW
4y	58	1 664155000		MUTTER		NUT
4y	59	1 664394508		KNAUF		KNOB
4y	60	2 664793102		SCHRAUBE		SCREW
4y	61	2 664155000		MUTTER		NUT
4y	62	1 664357702		SCHILD, VORSCHUB		LABEL, FEED RATE
4y	63	1 664028487		SCHALTERAUFNAHME		MICRO SWITCH BRACKET
4y	64	1 664410614		MIKROSCHALTER		MICRO SWITCH
4y	65	1 664028488		SCHALTERAUFNAHME		MICRO SWITCH BRACKET
4y	66	2 664792611		SCHRAUBE		SCREW
4y	67	2 664293201		MUTTER		NUT
4y	71	1 664002092		STANGE		ROD
4y	74	2 664670011		SCHEIBE		WASHER
4y	75	1 664155010		MUTTER		NUT
4y	80	1 664207101		BOWDENZUG		BOWDEN CABLE
4y	81	1 664772105		FÜHRUNG		CLAMP
4y	82	2 664791400		SCHRAUBE		SCREW
4y	83	2 664521331		LAGERBUCHSE		BUSHING
4y	84	2 664292102		MUTTER		NUT
4y	85	1 664034074		STANGE		ROD
4y	86	1 664100402		BOLZEN		PIN
4y	87	2 664293200		MUTTER		NUT
4y	88	3 664670011		SCHEIBE		WASHER
4y	89	1 664155010		MUTTER		NUT
4y	91	1 664487997		SPLINT		COTTER PIN
4y	93	2 664670011		SCHEIBE		WASHER
4y	100	1 664546059		PLATTE		PLATE
4y	101	1 664546061		PLATTE		PLATE
4y	102	2 664735120		SCHRAUBE		SCREW
4y	103	2 664040614		LAGER		BEARING
4y	104	1 664001029		ACHSE		AXLE
4y	105	2 664608900		SICHERUNGSRING		RETAINING RING
4y	106	1 664034089		STANGE		ROD
4y	107	1 664510111		BOLZEN		PIN
4y	108	1 664487997		SPLINT		COTTER PIN
4y	109	1 664028489		BOLZEN		PIN
4y	110	1 664487997		SPLINT		COTTER PIN
4y	111	1 664063023		NOCKEN		CAM
4y	112	1 664793102		SCHRAUBE		SCREW
4y	113	1 664521331		LAGERBUCHSE		BUSHING
4y	114	1 664155000		MUTTER		NUT
4y	115	1 664546019		PLATTE		PLATE
4y	116	2 664735602		SCHRAUBE		SCREW
4y	117	2 664581100		FEDERRING		SPRING RING
4y	118	2 664581100		FEDERRING		SPRING RING
4y	119	2 664290791		MUTTER		NUT
4y	120	1 664521350		SCHEIBE		WASHER
4y	121	1 664436050		PLATTE		PLATE
4y	122	1 664410609		MIKROSCHALTER LEERLAUF		SWITCH

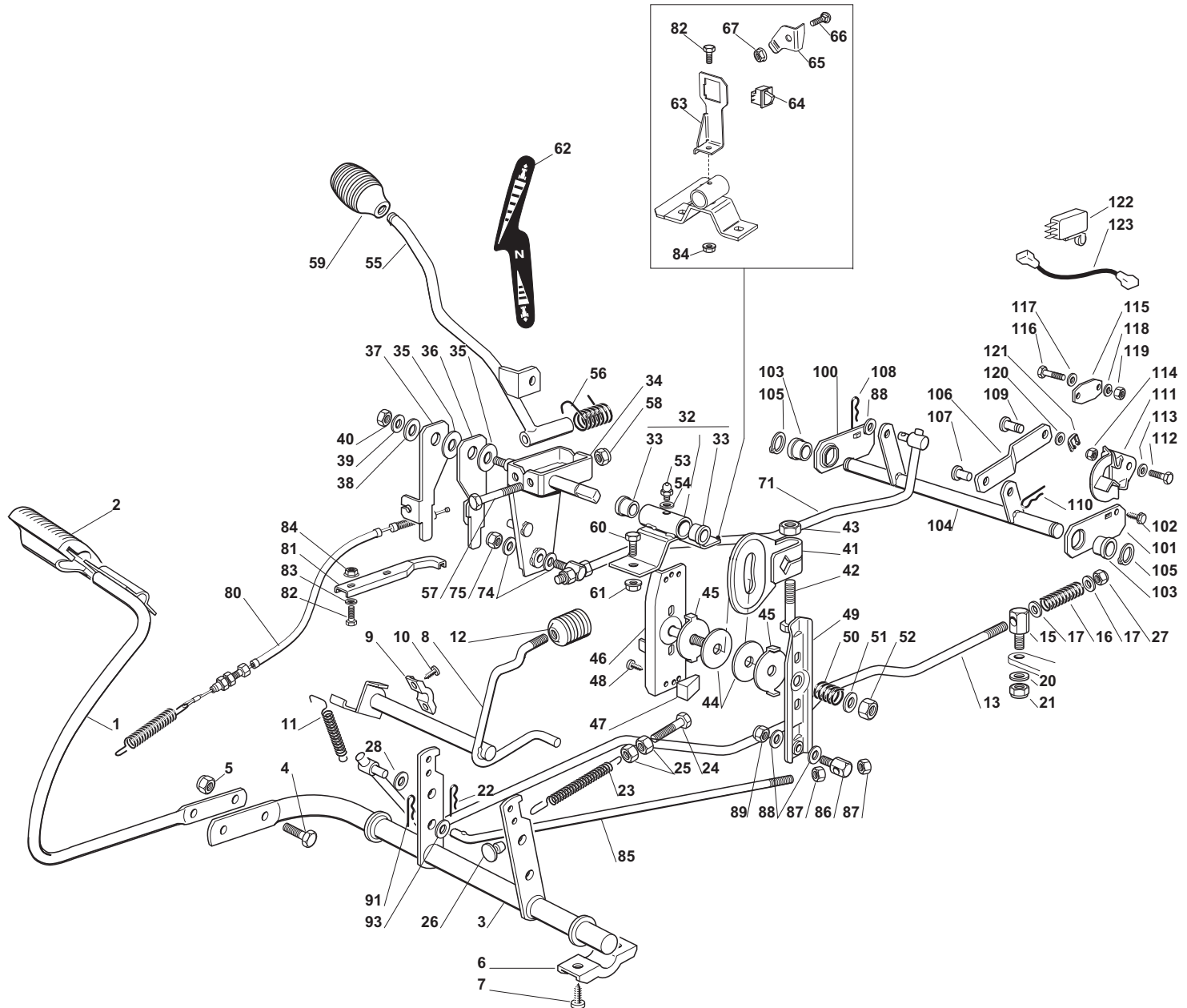

RM7213H (2015-2018)

4y

GETRIEBE UND BREMSE ANTRIEB
DRIVE AND BRAKE CONTROLS



Seite / Page	Pos.	Teil-Nr. Part No.	Hinweise Notes	Bezeichnung	Spezifikation Specification	Description
4y	123	1 664065025		KABEL		CABLE

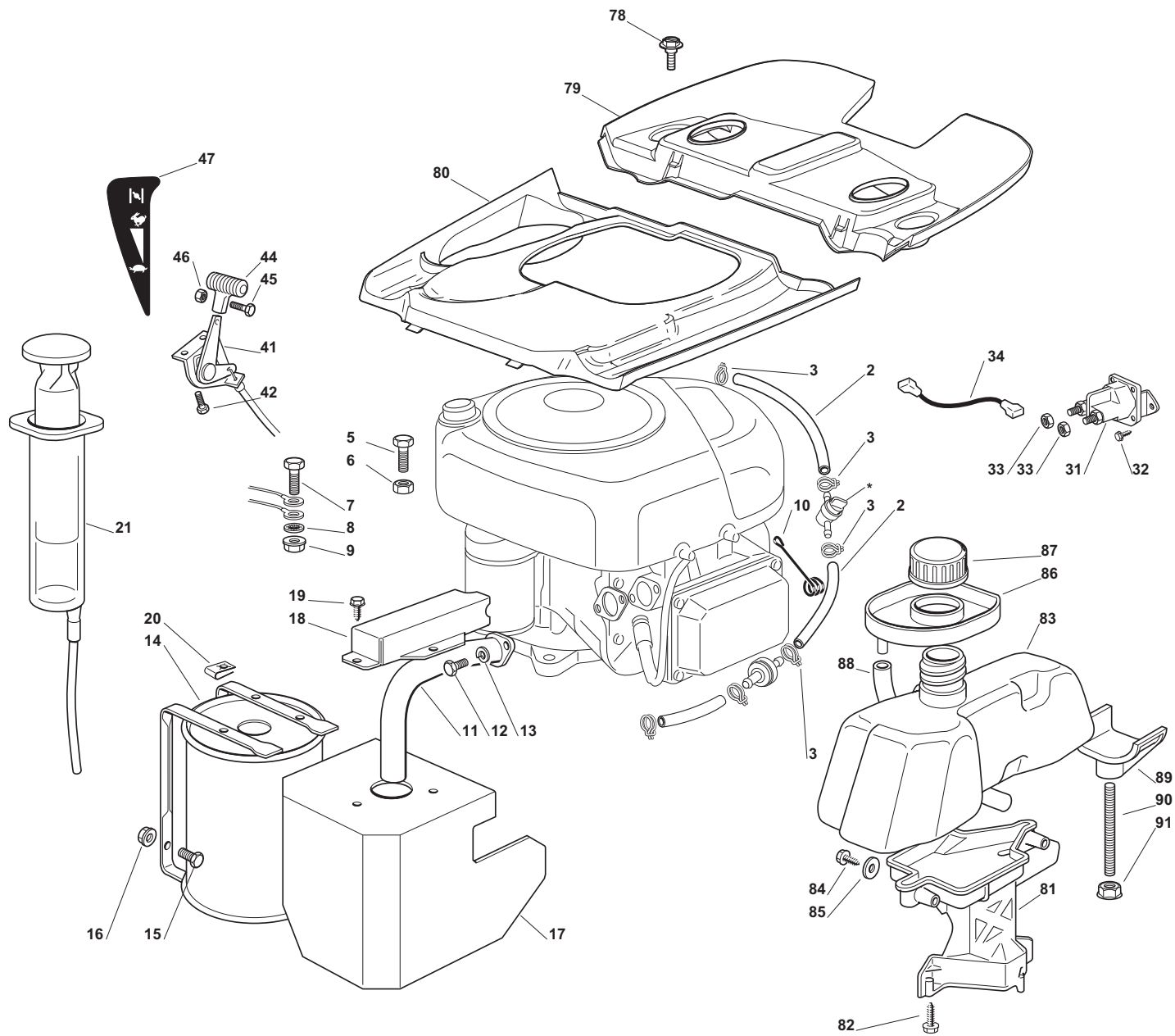

RM7213H (2015-2018)

5

Motor
Motor

Seite / Page	Pos.	Teil-Nr. Part No.	Hinweise Notes	Bezeichnung	Spezifikation Specification	Description
5	2	664869035		SCHLAUCH		HOSE
5	3	664375051		SCHLAUCHKLEMME		HOSE CLAMP
5	5	664691100		SCHRAUBE		SCREW
5	6	664154210		MUTTER		NUT
5	7	664691115		SCHRAUBE		SCREW
5	8	664540260		SCHEIBE		WASHER
5	9	664154210		MUTTER		NUT
5	10	664430239		FEDER		SPRING
5	11	664738225		AUSPUFFANSCHLUSS		EXHAUST CONNECTION
5	12	664737450		SCHRAUBE		SCREW
5	13	664583500		FEDERRING		GROWER
5	14	664500062	=> 2017	SCHALLDÄMPFER		MUFFLER
5	14	664750059	2018 =>	SCHALLDÄMPFER		MUFFLER
5	15	664793102		SCHRAUBE		SCREW
5	16	664154210		MUTTER		NUT
5	17	664598081		AUSPUFFSCHUTZ		GUARD
5	18	664001371		SCHUTZ		PROTECTION
5	19	664729601		SCHRAUBE		SCREW
5	20	664437504		PLATTE		PLATE
5	21	664718000		SPRITZE		SYRINGE
5	31	664736110	=> 2017	ANLASSRELAIS		STARTER RELAY
5	31	664736113	2018 =>	ANLASSRELAIS		STARTER RELAY
5	32	664735110		SCHRAUBE		SCREW
5	33	664360352		MUTTER		NUT
5	34	664065050		KABEL		CABLE
5	41	664999250		GASZUG		BOWDEN CABLE
5	42	664943012		SCHRAUBE		SCREW
5	44	664394501		GRIFF		HANDLE
5	45	664726389		SCHRAUBE		SCREW
5	46	664290800		MUTTER		NUT
5	47	664028491		SCHILD, MOTORFERNBEDIENUNG		LABEL, THROTTLE
5	78	664943010		SCHRAUBE		SCREW
5	79	664110515		ABDECKUNG		COVER
5	80	664105060		MOTORHAUBE		ENGINE COVER
5	81	664787062		HALTER		SUPPORT
5	82	664735410		SCHRAUBE		SCREW
5	83	664733003		TANK		TANK
5	84	664735410		SCHRAUBE		SCREW
5	85	664523040		SCHEIBE		WASHER
5	86	664600061		SCHUTZ		PROTECTION
5	87	664795000		TANKVERSCHLUSS		CAP
5	88	664999014		ROHR		TUBE
5	89	664787063		HALTER		SUPPORT
5	90	664510118		BOLZEN		PIN
5	91	664293201		MUTTER		NUT

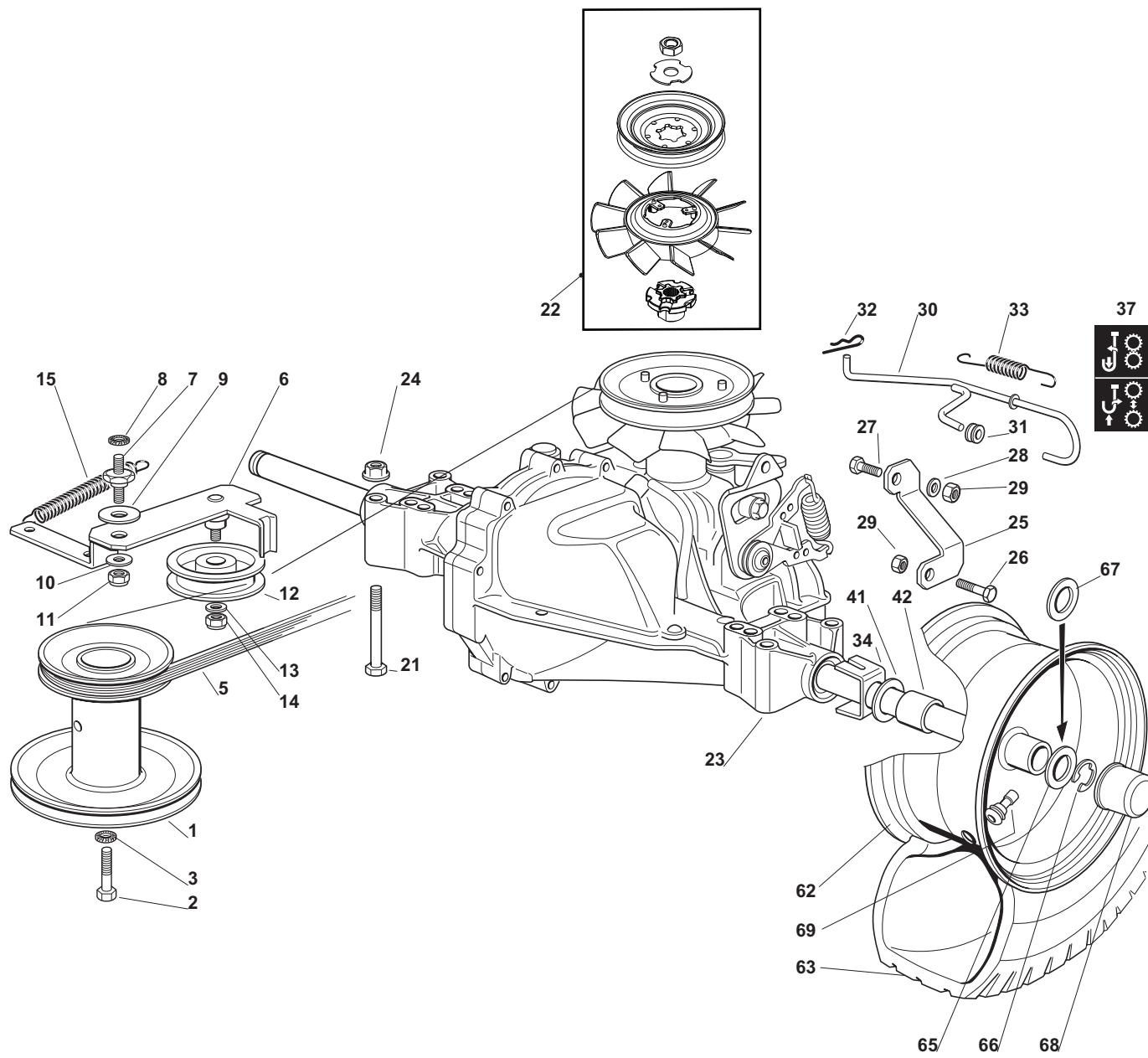

RM7213H (2015-2018)

6y

Getriebe
Gear

Seite / Page	Pos.	Teil-Nr. Part No.	Hinweise Notes	Bezeichnung	Spezifikation Specification	Description
6y	1	664604005		RIEMENSCHLEIBE		PULLEY
6y	2	664737310		SCHRAUBE		SCREW
6y	3	664543000		SCHLEIBE		WASHER
6y	5	664061407		RIEMEN		BELT
6y	6	664317067		HEBEL		LEVER
6y	7	664510096		BOLZEN		PIN
6y	8	664540260		SCHLEIBE		WASHER
6y	9	664672151		SCHLEIBE		WASHER
6y	10	664670011		SCHLEIBE		WASHER
6y	11	664155010		MUTTER		NUT
6y	12	664601554		RIEMENSCHLEIBE		PULLEY
6y	13	664523060		SCHLEIBE		WASHER
6y	14	664155000		MUTTER		NUT
6y	15	664446402		FEDER		SPRING
6y	21	664691900		SCHRAUBE		SCREW
6y	22	664392202	2018 =>	LÜFTERRAD KPL.		FAN KIT
6y	23	664400976		HINTERACHSE	Hydro-Gear T2-Bdbe-2X1A-16X1	REAR AXLE
6y	24	664154210		MUTTER		NUT
6y	25	664787075		HALTER		SUPPORT
6y	26	664691400		SCHRAUBE		SCREW
6y	27	664793102		SCHRAUBE		SCREW
6y	28	664521350		SCHLEIBE		WASHER
6y	29	664155000		MUTTER		NUT
6y	30	664002087		HEBEL		LEVER
6y	31	664564512		KABELDURCHGANG		FAIR LEAD
6y	32	664487997		SPLINT		COTTER PIN
6y	33	664430213		FEDER		SPRING
6y	34	664670058		SCHLEIBE		WASHER
6y	37	664365167		SCHILD		LABEL
6y	41	664670006		SCHLEIBE		WASHER
6y	42	664160059		DISTANZBUCHSE		SPACER
6y	62	664044013		HINTERRAD FELGE		RIMM
6y	63	664590019		REIFEN	15 x 600-6	TYRE
6y	65	664670005		SCHLEIBE		WASHER
6y	66	664001010		SPRENGRING		SNAP RING
6y	67	0-4 664670006		SCHLEIBE		WASHER
6y	68	664110230		NABENDECKEL		HUB COVER
6y	69	664950000		VENTIL		VALVE

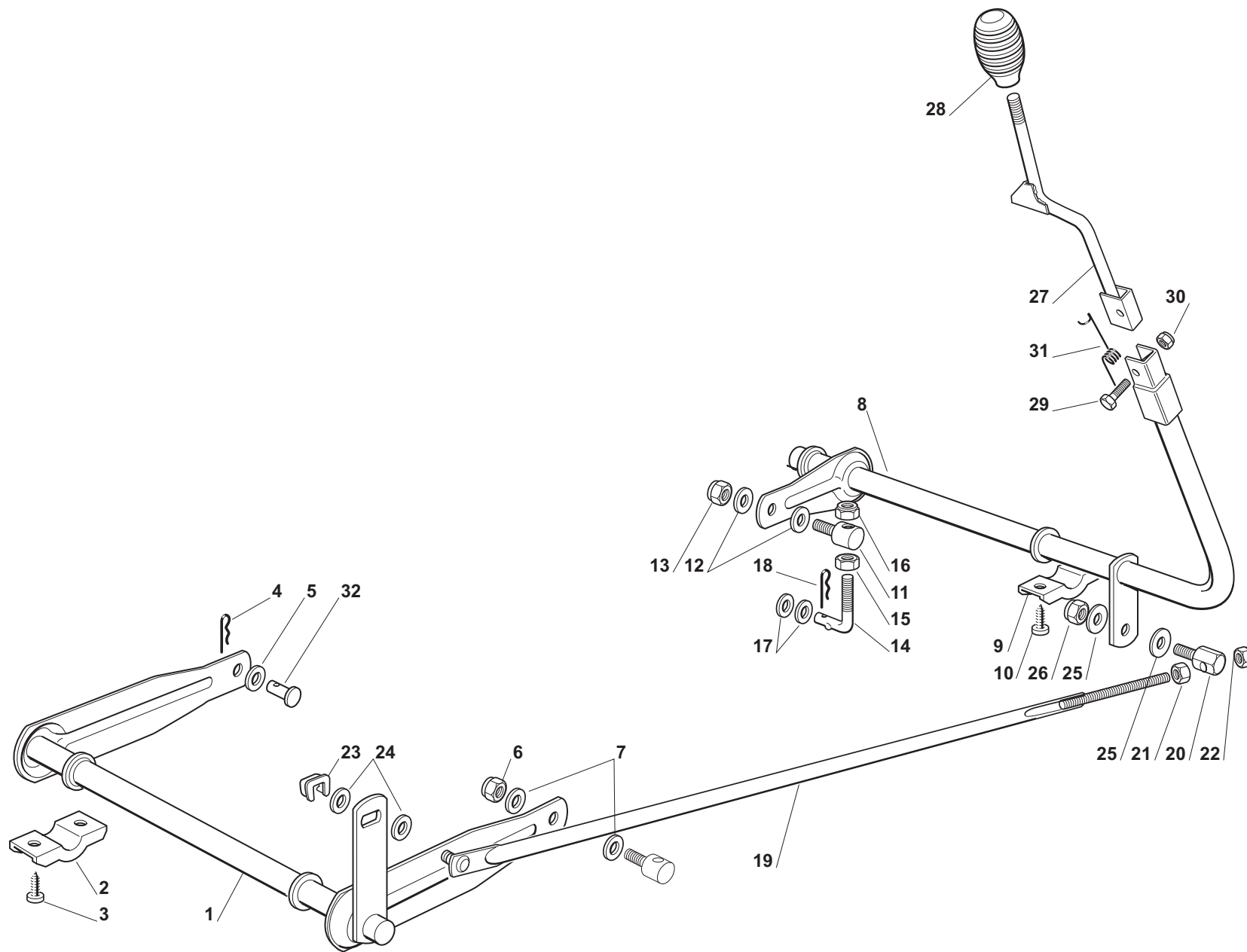



Seite / Page	Pos.	Teil-Nr. Part No.	Hinweise Notes	Bezeichnung	Spezifikation Specification	Description
7	1	664001025		ACHSE		AXLE
7	2	664546015		PLATTE		PLATE
7	3	664731350		SCHRAUBE		SCREW
7	4	664487997		SPLINT		COTTER PIN
7	5	664670008		SCHEIBE		WASHER
7	6	664156602		MUTTER		NUT
7	7	664670008		SCHEIBE		WASHER
7	8	664001005		ACHSE		AXLE
7	9	664546015		PLATTE		PLATE
7	10	664731350		SCHRAUBE		SCREW
7	11	664510007		BOLZEN		PIN
7	12	664670008		SCHEIBE		WASHER
7	13	664156602		MUTTER		NUT
7	14	664840003		SPANNSTANGE		TIE ROD
7	15	664295200		MUTTER		NUT
7	16	664156602		MUTTER		NUT
7	17	664672150		SCHEIBE		WASHER
7	18	664487997		SPLINT		COTTER PIN
7	19	664002051		STAB		ROD
7	20	664100402		BOLZEN		PIN
7	21	664293200		MUTTER		NUT
7	22	664155000		MUTTER		NUT
7	23	664436050		PLATTE		PLATE
7	24	664670011		SCHEIBE		WASHER
7	25	664670011		SCHEIBE		WASHER
7	26	664155000		MUTTER		NUT
7	27	664317065		HEBEL		LEVER
7	28	664394510		GRIFF		KNOB
7	29	664674700		SCHRAUBE		SCREW
7	30	664154510		MUTTER		NUT
7	31	664430555		FEDER		SPRING
7	32	664510114		BOLZEN		PIN

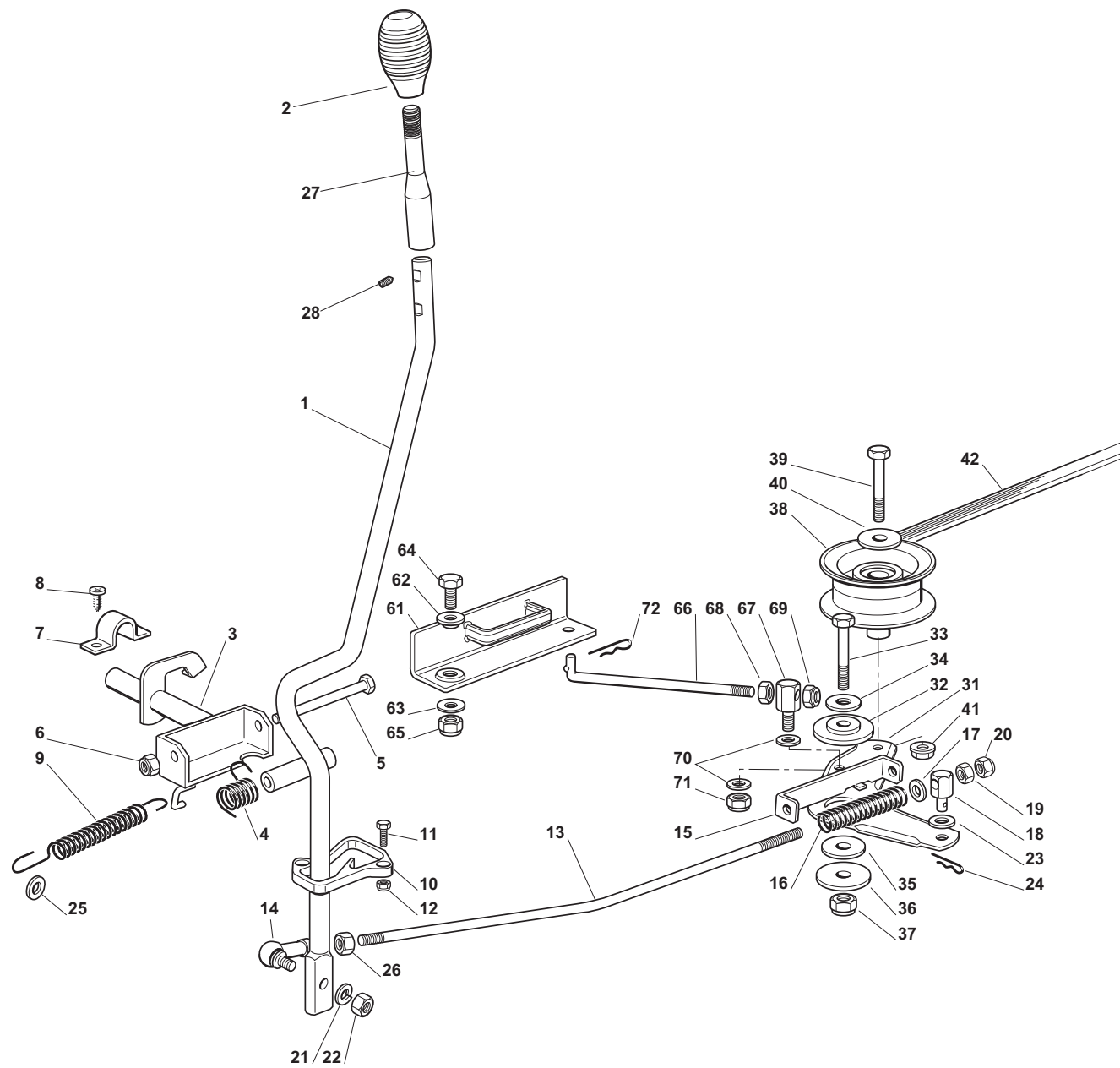



Seite / Page	Pos.	Teil-Nr. Part No.	Hinweise Notes	Bezeichnung	Spezifikation Specification	Description
8	1	664315134		HEBEL		LEVER
8	2	664394510		GRIFF		KNOB
8	3	664001007		ACHSE		AXLE
8	4	664430226		FEDER		SPRING
8	5	664692050		SCHRAUBE	M8x85	SCREW
8	6	664155000		MUTTER		NUT
8	7	664547049		PLATTE		PLATE
8	8	664731601		SCHRAUBE		SCREW
8	9	664305711		FEDER		SPRING
8	10	664487000		GLEITBLOCK		SHOE
8	11	664791213		SCHRAUBE		SCREW
8	12	664154510		MUTTER		NUT
8	13	664034078		STAB		ROD
8	14	664746610	=> 2017	GELENK		JOINT
8	14	664746601	2018 =>	GELENK		JOINT
8	15	664772143		KLAMMER FEDERDÄMPFER		CLAMP
8	16	664430576		FEDER		SPRING
8	17	664521350		SCHEIBE		WASHER
8	18	664510113		BOLZEN		PIN
8	19	664293200		MUTTER		NUT
8	20	664155000		MUTTER		NUT
8	21	664583500		FEDERRING		GROWER
8	22	664293200		MUTTER		NUT
8	23	664670008		SCHEIBE		WASHER
8	24	664487997		SPLINT		COTTER PIN
8	25	664670006		SCHEIBE		WASHER
8	26	664293200		MUTTER		NUT
8	27	664317103		DISTANZRING		SPACER
8	28	664714250		STIFT		DOWEL
8	31	664317083		HEBEL		LEVER
8	32	664047000		BUCHSE		BUSH
8	33	664691200		SCHRAUBE		SCREW
8	34	664523060		SCHEIBE		WASHER
8	35	664672152		SCHEIBE		WASHER
8	36	664523070		SCHEIBE		WASHER
8	37	664155000		MUTTER		NUT
8	38	664604008		RIEMENSCHLEIBE		PULLEY
8	39	664691600		SCHRAUBE		SCREW
8	40	664523060		SCHEIBE		WASHER
8	41	664293201		MUTTER		NUT
8	42	664061423		KEILRIEMEN MAHWERK		V-BELT, MOWER
8	61	664220501		BREMSE		BRAKE
8	62	664041980		BUCHSE		BUSH
8	63	664672152		SCHEIBE		WASHER
8	64	664793102		SCHRAUBE		SCREW
8	65	664155010		MUTTER		NUT
8	66	664034077		STAB		ROD
8	67	664100402		BOLZEN		PIN
8	68	664293200		MUTTER		NUT
8	69	664155000		MUTTER		NUT

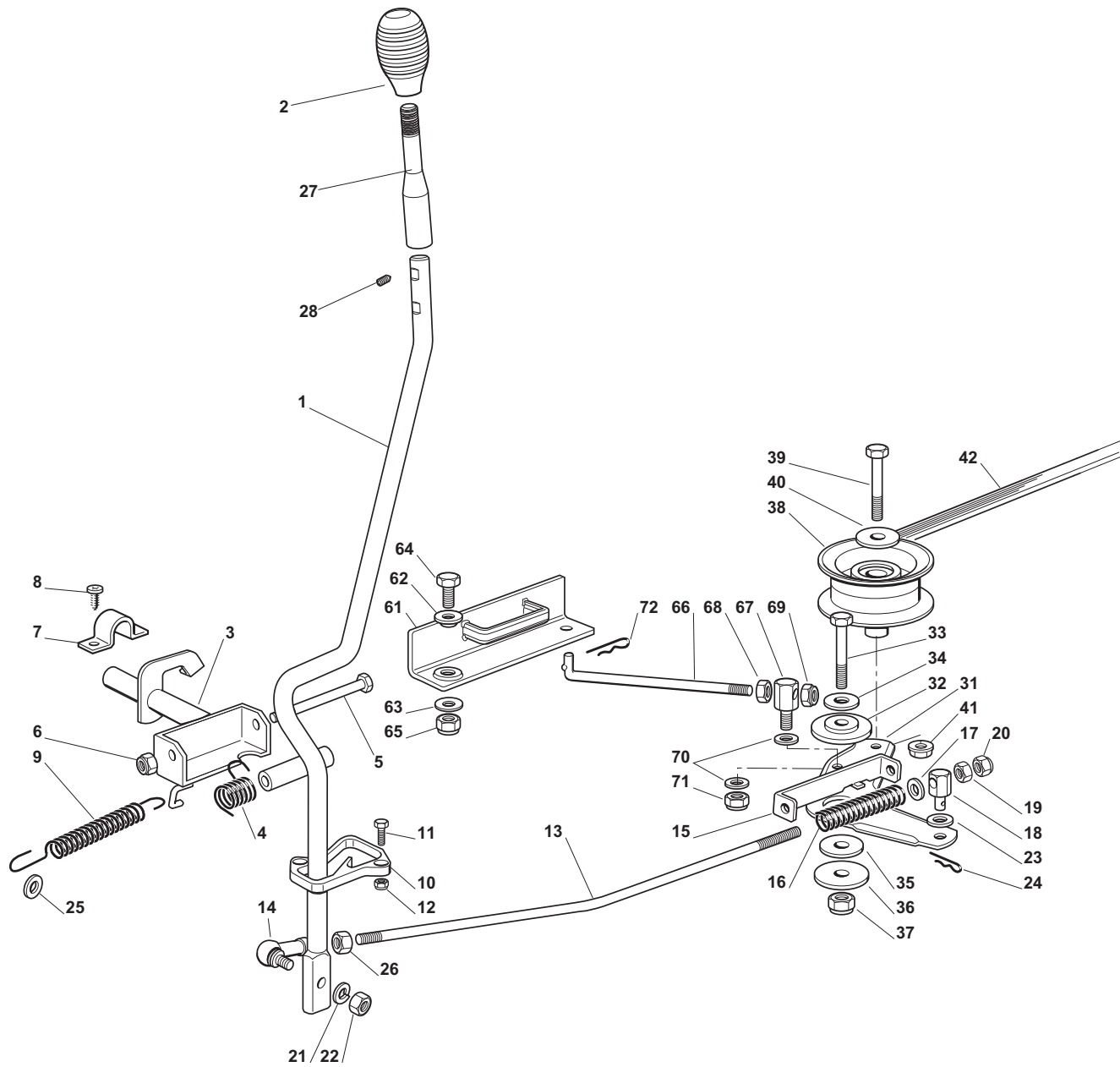

RM7213H (2015-2018)

8

SCHNEIDWERKZEUG (1)
CUTTING PLATE (1)



Seite / Page	Pos.	Teil-Nr. Part No.	Hinweise Notes	Bezeichnung	Spezifikation Specification	Description
8	70	2 664670011		SCHEIBE		WASHER
8	71	1 664155000		MUTTER		NUT
8	72	1 664487997		SPLINT		COTTER PIN

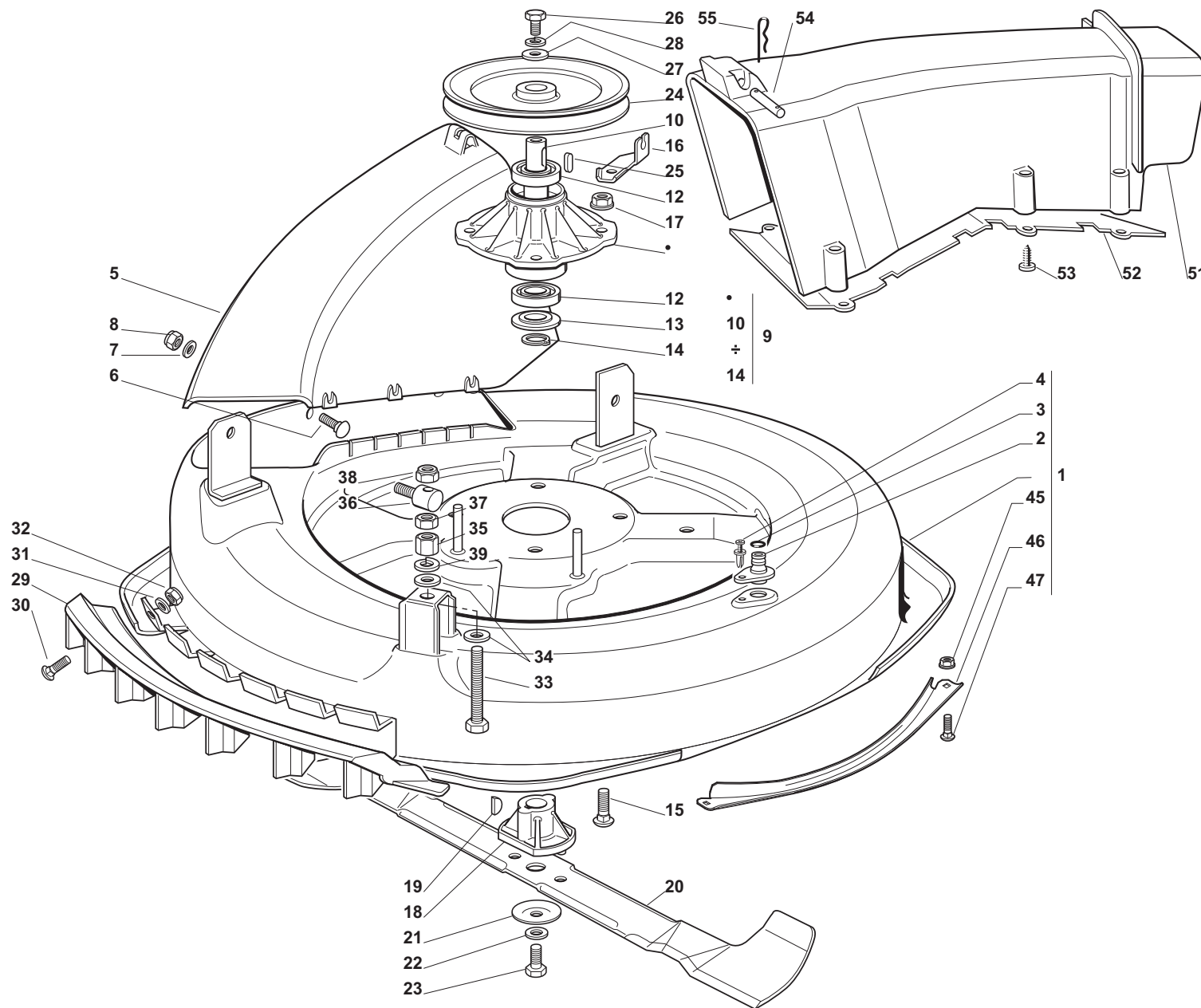



Seite / Page	Pos.	Teil-Nr. Part No.	Hinweise Notes	Bezeichnung	Spezifikation Specification	Description
9	1	664564111		MÄHDECK	INC. 2-4,45-47	PLATE
9	2	664033060		WASSERANSCHLUSS		WATER HOSE CONNECTION
9	3	664035000		O-RING		O-RING
9	4	664500030		NIET		RIVET
9	5	664998000		BLECHSATZ		CONVEYOR
9	6	664815210		SCHRAUBE		SCREW
9	7	664523040		SCHEIBE		WASHER
9	8	664154510		MUTTER		NUT
9	9	664207250		NABE, KPL.	INC. 10-14	FLANGE ASSY.
9	10	664023000		WELLE		SHAFT
9	12	664216047		KUGELLAGER		BALL BEARING
9	13	664160501		STAUBSCHUTZSCHEIBE		DUST COVER
9	14	664609260		SICHERUNGSRING		RETAINING RING
9	15	664818700		SCHRAUBE		SCREW
9	16	664787067	2018 =>	HALTERUNG		SUPPORT
9	17	664154210		MUTTER		NUT
9	18	664463200		MESSERHALTER		BLADE HUB
9	19	664139100		KEIL		KEY
9	20	664109502		FANGMESSER		BLADE (COLLECT)
9	21	664160400		FEDERSCHEIBE		ELASTIC WASHER
9	22	664523080		SCHEIBE		WASHER
9	23	664735694		SCHRAUBE	R	SCREW
9	24	664604009		RIEMENSCHNEIBE		PULLEY
9	25	664139480		KEIL		KEY
9	26	664793102		SCHRAUBE		SCREW
9	27	664670007		SCHEIBE		WASHER
9	28	664583500		FEDERRING		GROWER
9	29	664488000		ANSAUGGITTER		AIR INTAKE GRILL
9	30	664815200		SCHRAUBE		SCREW
9	31	664521340		SCHEIBE		WASHER
9	32	664154510		MUTTER		NUT
9	33	664794970		SCHRAUBE		SCREW
9	34	664523080		SCHEIBE		WASHER
9	35	664154250		MUTTER		NUT
9	36	664510007		BOLZEN		PIN
9	37	664295200		MUTTER		NUT
9	38	664156602		MUTTER		NUT
9	39	664585100		FEDERRING		GROWER
9	45	664154510		MUTTER		NUT
9	46	664543009		ABSCHLUßBLECH, SCHWARZ		DECK PROFILE, BLACK
9	47	664815210		SCHRAUBE		SCREW
9	51	664107501		BLECHSATZ		CONVEYOR
9	52	664140051		ABWEISER		DEFLECTOR
9	53	664735403		SCHRAUBE		SCREW
9	54	664510097		BOLZEN		PIN
9	55	664487997		SPLINT		COTTER PIN

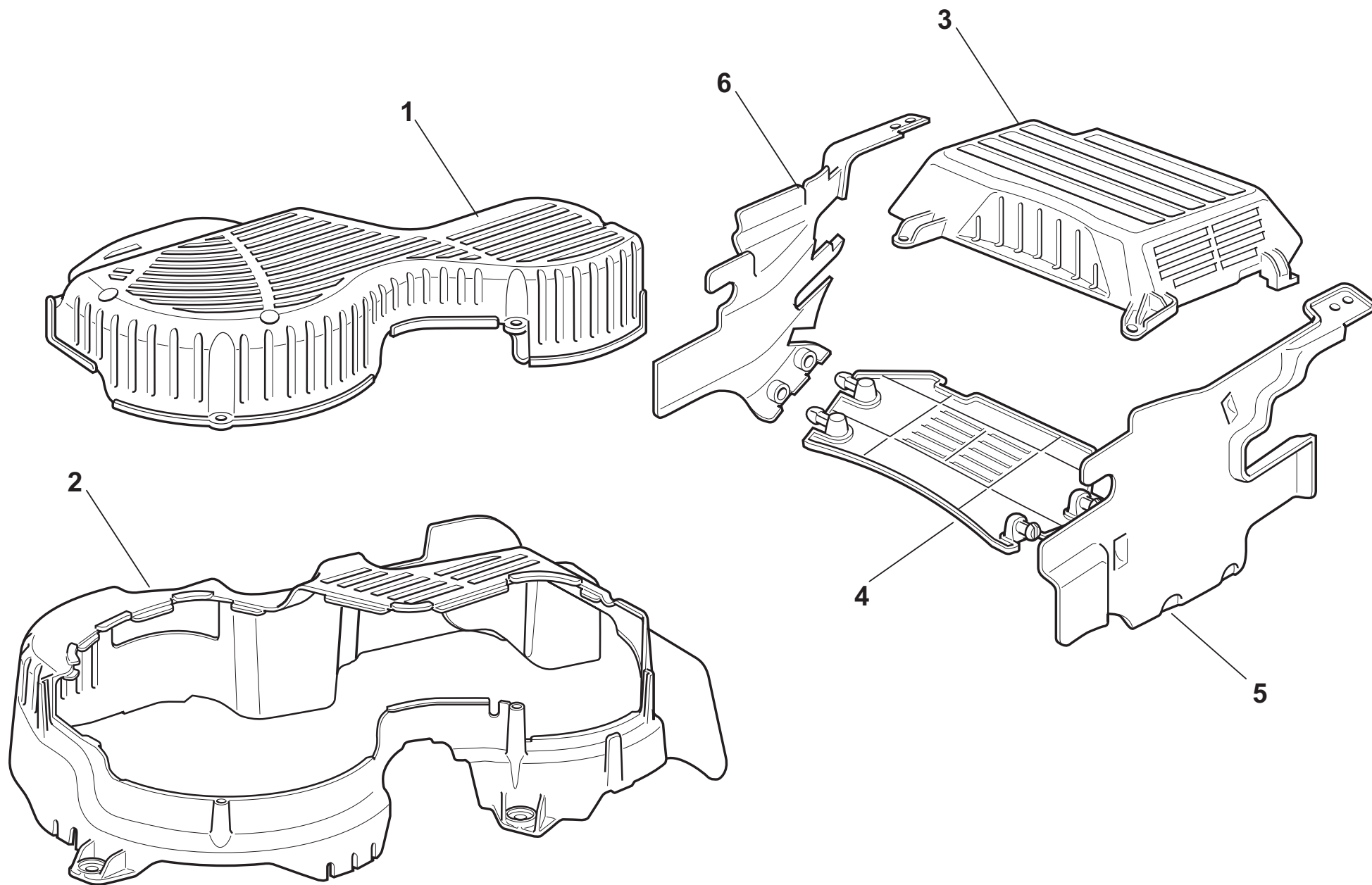

RM7213H (2015-2018)

9a

Schutz
Protection



Seite / Page	Pos.	Teil-Nr. Part No.	Hinweise Notes	Bezeichnung	Spezifikation Specification	Description
9a	1	664060136		SCHUTZ	F	PROTECTION
9a	2	664060137		SCHUTZ	F	PROTECTION
9a	3	664060138		SCHUTZ	F	PROTECTION
9a	4	664060141		SCHUTZ	F	PROTECTION
9a	5	664060140		SCHUTZ	F	PROTECTION
9a	6	664060139		SCHUTZ	F	PROTECTION

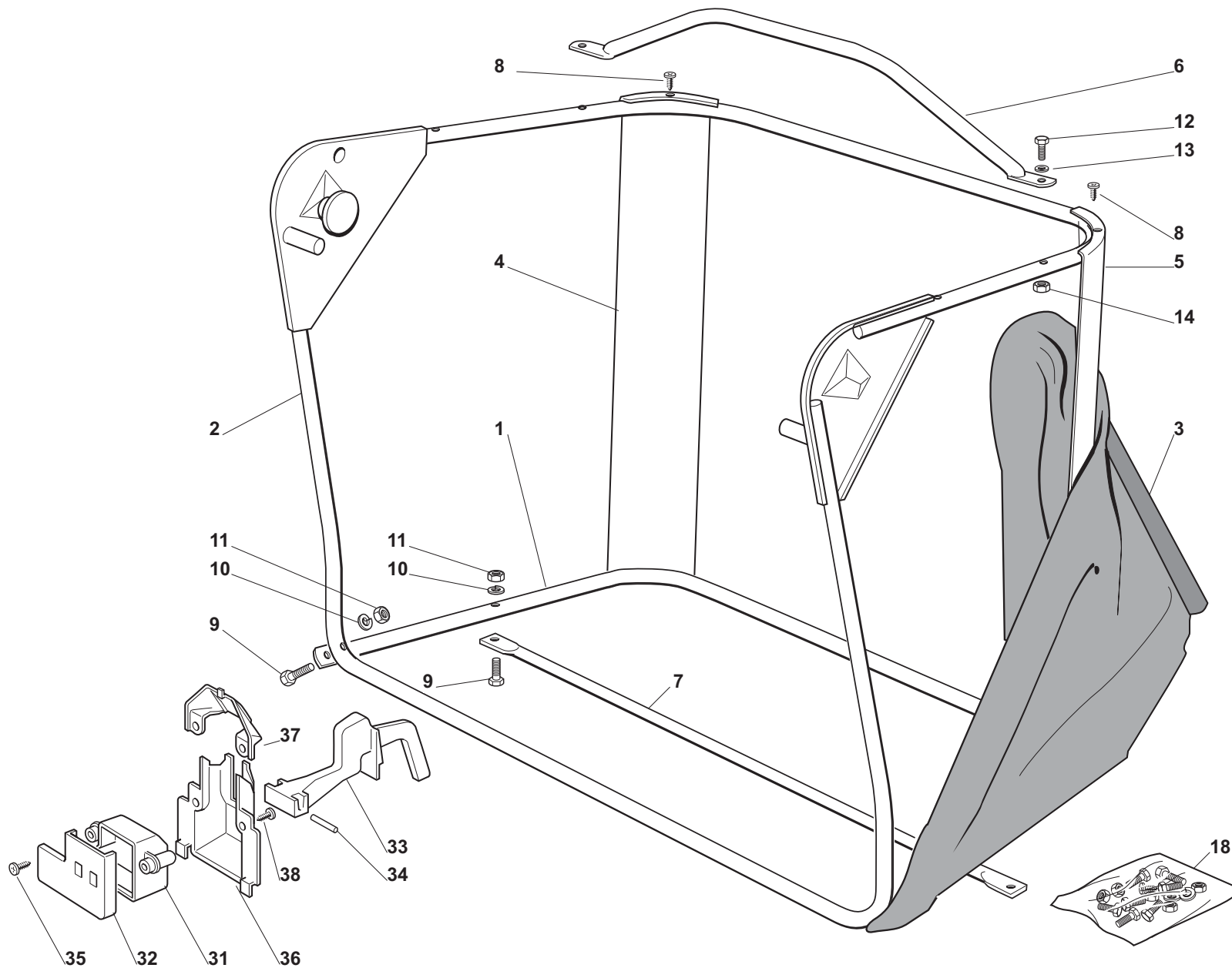

RM7213H (2015-2018)

10

GRASS-SACK
GRASSCATCHER

Seite / Page	Pos.	Teil-Nr. Part No.	Hinweise Notes	Bezeichnung	Spezifikation Specification	Description
10	1	664801103		UNTERERRAHMEN		LOWER FRAME
10	2	664801105		OBERERRAHMEN		UPPER FRAME
10	3	664106069		GRASS-SACK		GRASS CATCHER
10	4	664010205		HALTER RECHTS		SUPPORT RIGHT
10	5	664010207		HALTER LINKS		SUPPORT LEFT
10	6	664869051		STANGE		ROD
10	7	664650100		VERSTÄRKUNG		STIFFENING
10	8	664729601		SCHRAUBE		SCREW
10	9	664792099		SCHRAUBE		SCREW
10	10	664582101		FEDERRING		GROWER
10	11	664292100		MUTTER		NUT
10	12	664674701		SCHRAUBE		SCREW
10	13	664521331		LAGERBUCHSE		BUSHING
10	14	664154510		MUTTER		NUT
10	18	664180180		SCHRAUBENAUSRÜSTUNG		SCREWS OUTFIT
10	31	664600041		SCHUTZ		PROTECTION
10	32	664600042		SCHUTZDECKEL		PROTECTION COVER
10	33	664318124		HEBEL		LEVER
10	34	664400030		BOLZEN		PIN
10	35	664728510		SCHRAUBE		SCREW
10	36	664600047		SCHUTZ		PROTECTION
10	37	664600048		ABWEISERDECKEL		DEFLECTOR COVER
10	38	664728450		SCHRAUBE		SCREW

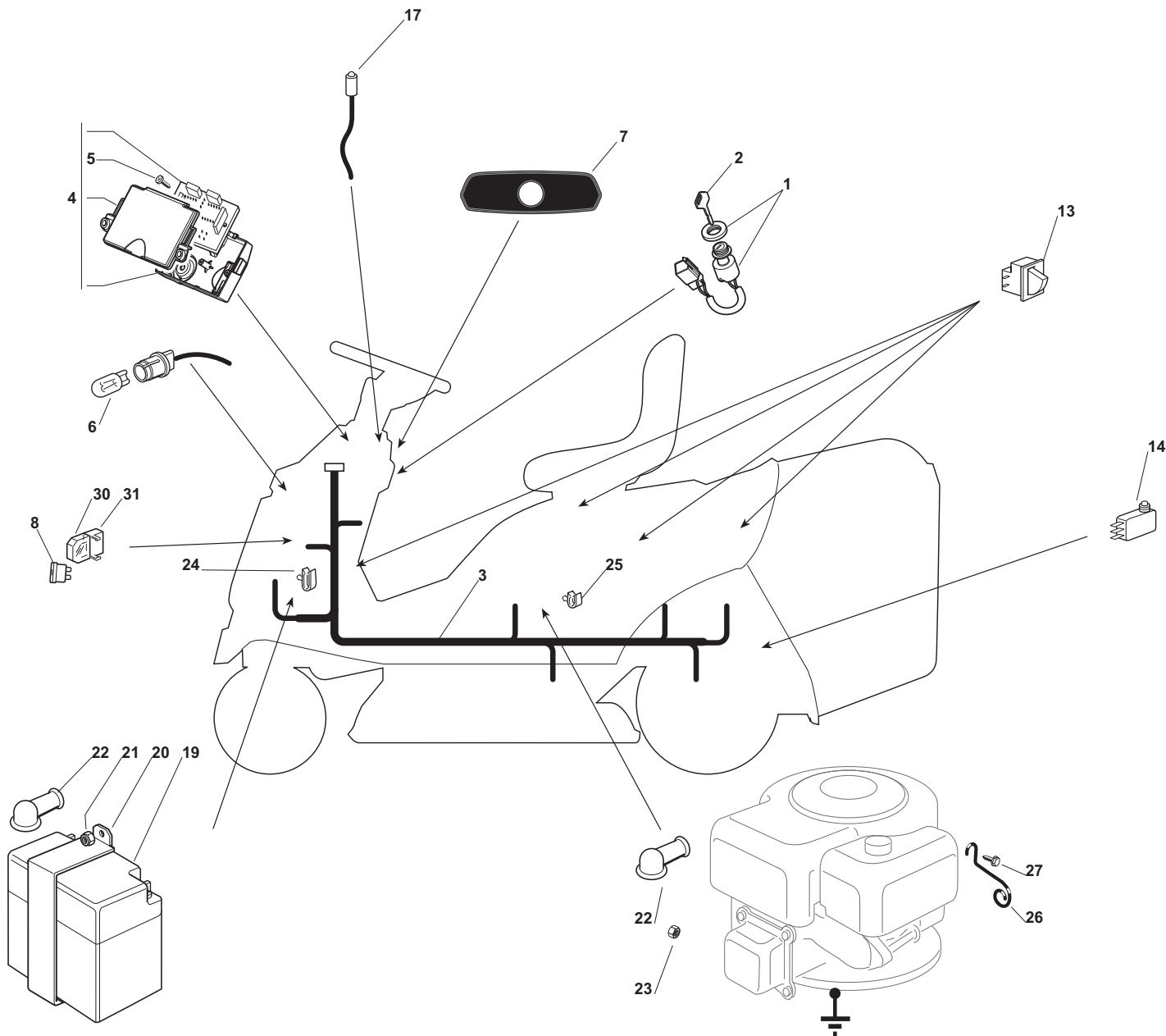



Seite / Page	Pos.	Teil-Nr. Part No.	Hinweise Notes	Bezeichnung	Spezifikation Specification	Description
11	1	664450075		SCHALTER		STARTING SWITCH
11	2	664210023		SCHLÜSSEL FÜR START		STARTING KEY
11	3	664028493		KABELSATZ		CABLES
11	4	664028494		ELEKTRONISCHE KARTE	INC. 5	ELECTRONIC CARD
11	5	664735101		SCHRAUBE		SCREW
11	6	664459100		LAMPE HALOGEN		LAMP, HALOGEN
11	7	664420022		KONTROLLKONSOLE		CONTROL PANEL
11	8	664340035		SICHERUNG	15A	FUSE
11	8	664340040		SICHERUNG	10A	FUSE
11	13	664410613		MIKROSCHALTER		MICRO SWITCH
11	14	664410605		FÜLLHÖHENSCHALTER		FULL GRASS CATCHER MICRO
11	17	664065014		KABEL		CABLE
11	19	664120002		BATTERIE		BATTERY
11	20	664772099		BATTERIEHALTER		CLAMP
11	21	664155000		MUTTER		NUT
11	22	664564861		STECKER		PROTECTION
11	23	664361005		MUTTER		NUT
11	24	664320506		KABELBEFESTIGUNG		FAIRLEAD
11	25	664320504		KABELBEFESTIGUNG		FAIRLEAD
11	26	664430561		FEDER		SPRING
11	27	664735121	=> 2017	SCHRAUBE		SCREW
11	27	664735122	2018 =>	SCHRAUBE		SCREW
11	30	664215000		DECKEL		COVER
11	31	664500007		SICHERUNGHALTER		FUSE CARRIER

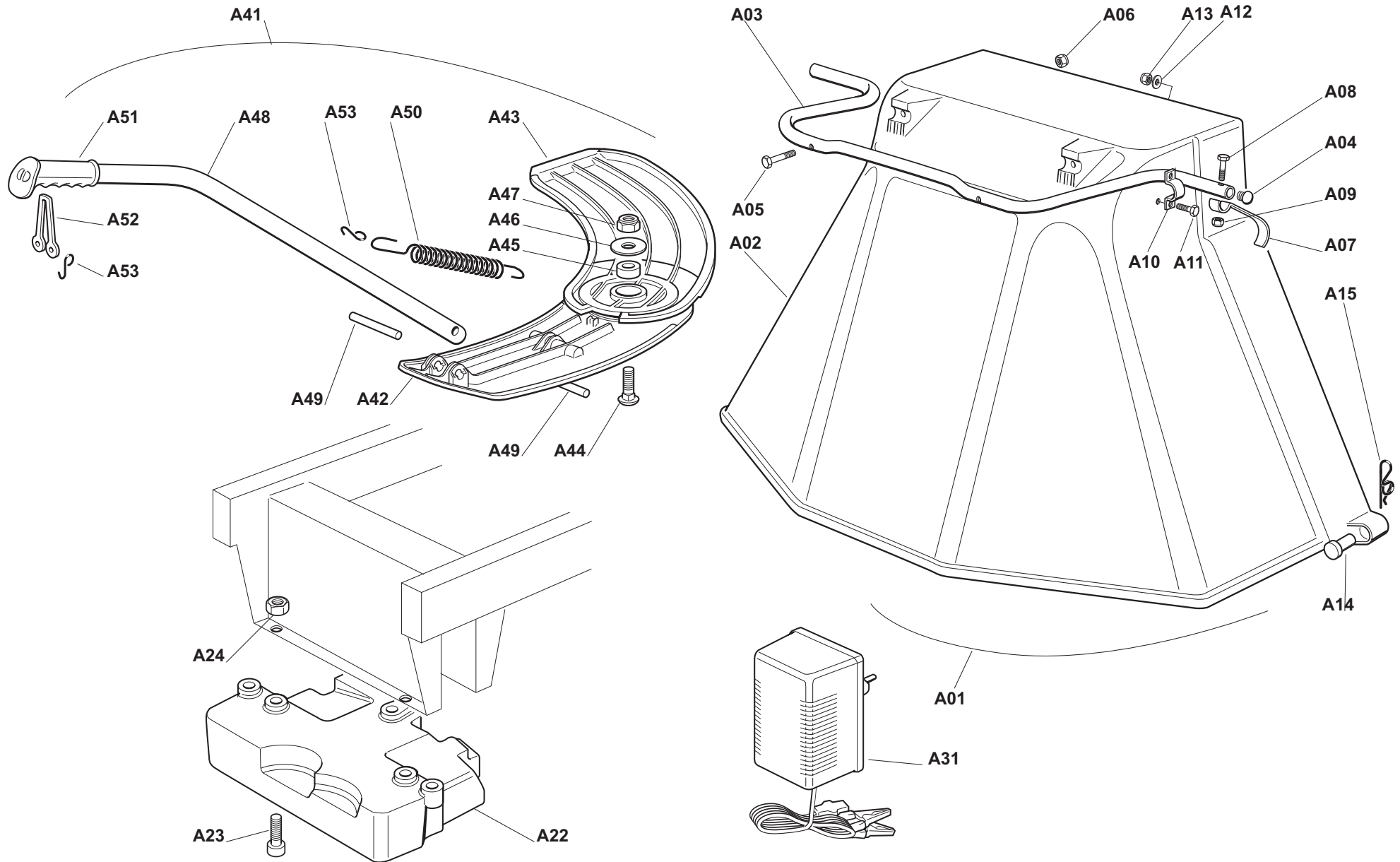

RM7213H (2015-2018)

12

ZUBEHÖR NACH ANFRAGE
OPTIONALS ON REQUEST

Seite / Page	Pos.	Teil-Nr. Part No.	Hinweise Notes	Bezeichnung	Spezifikation Specification	Description
12	A01	664900090		DEFLEKTORHAUBE	SET INC. A02-A15	EJECTION-GUARD ASS.Y
12	A02	664598062		AUSWURFSCHUTZ		EJECTION GUARD
12	A03	664869053		HALTER		SUPPORT
12	A04	664566113		PFROPFEN		CAP
12	A05	664674701		SCHRAUBE		SCREW
12	A06	664154510		MUTTER		NUT
12	A07	664547053		PLÄTTCHEN		PLATE
12	A08	664791500		SCHRAUBE		SCREW
12	A09	664154510		MUTTER		NUT
12	A10	664547049		PLATTE		PLATE
12	A11	664788910		SCHRAUBE	M5x16	SCREW
12	A12	664523020		SCHEIBE		WASHER
12	A13	664154320		MUTTER		NUT
12	A14	664510022		BOLZEN		PIN
12	A15	664487998		SPLINT		COTTER PIN
12	A22	664519997		FRONTGEWICHT	72-92-102-122	FRONT WEIGHT
12	A23	664760520		SCHRAUBE		SCREW
12	A24	664155000		MUTTER		NUT
12	A31	664180050		LADEGERÄT	EU (SCHUKO)	BATTERY CHARGER
12	A31	664180052		LADEGERÄT	U.K.	BATTERY CHARGER
12	A41	664900036		MULCHKEIL		MULCHING KIT
12	A41	664900136		MULCHKEIL&MULCHMESSER	72 cm	MULCHING KIT (INCL. BLADE, MULCH)
12	A42	664140055		ABWEISER, HINTER		DEFLECTOR, REAR
12	A43	664140054		ABWEISER, VORDER		DEFLECTOR, FRONT
12	A44	664818700		SCHRAUBE		SCREW
12	A45	664028495		LAGERBUCHSE		BUSHING
12	A46	664672152		SCHEIBE		WASHER
12	A47	664155000		MUTTER		NUT
12	A48	664394003		STIEL		HANDLE
12	A49	664510116		BOLZEN		PIN
12	A50	664430229		FEDER		SPRING
12	A51	664280000		GRIFF		HANDGRIP
12	A52	664840011		GUMMIZUG		ELASTIC TIE-ROD
12	A53	664253004		HAKEN		HOOK

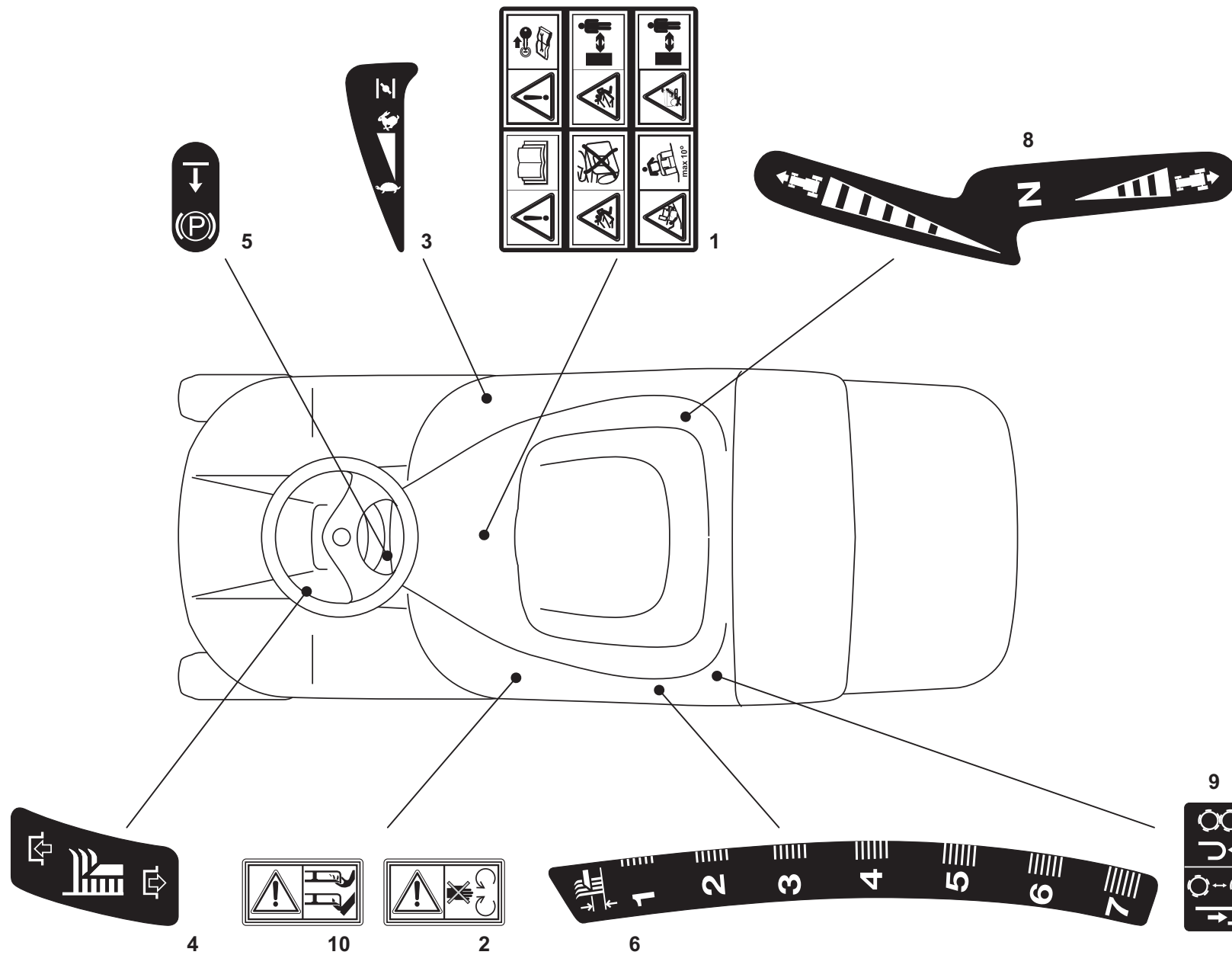



Seite / Page	Pos.	Teil-Nr. Part No.	Hinweise Notes	Bezeichnung	Spezifikation Specification	Description
13	1	664357428		SCHILD SICHERHEITSHINWEISE		LABEL, SAFETY INSTRUCTIONS
13	2	664998519		SCHILD SICHERHEITSHINWEISE		LABEL, SAFETY INSTRUCTIONS
13	3	664028491		SCHILD, MOTORFERNBEDIENUNG		LABEL, THROTTLE
13	4	664357431		SCHILD, MESSERKUPPLUNG		LABEL, KNIFE COUPLING
13	5	664998526		SCHILD, PARKBREMSE		LABEL, PARKING BRAKE
13	6	664357427		SCHILD, SCHNITTHÖHENVERSTELLUNG		LABEL, HEIGHT ADJUSTMENT
13	8	664357702		SCHILD, VORSCHUB		LABEL, FEED RATE
13	9	664365167		SCHILD		LABEL
13	10	664356699		SCHILD SICHERHEITSHINWEISE		LABEL, SAFETY INSTRUCTIONS

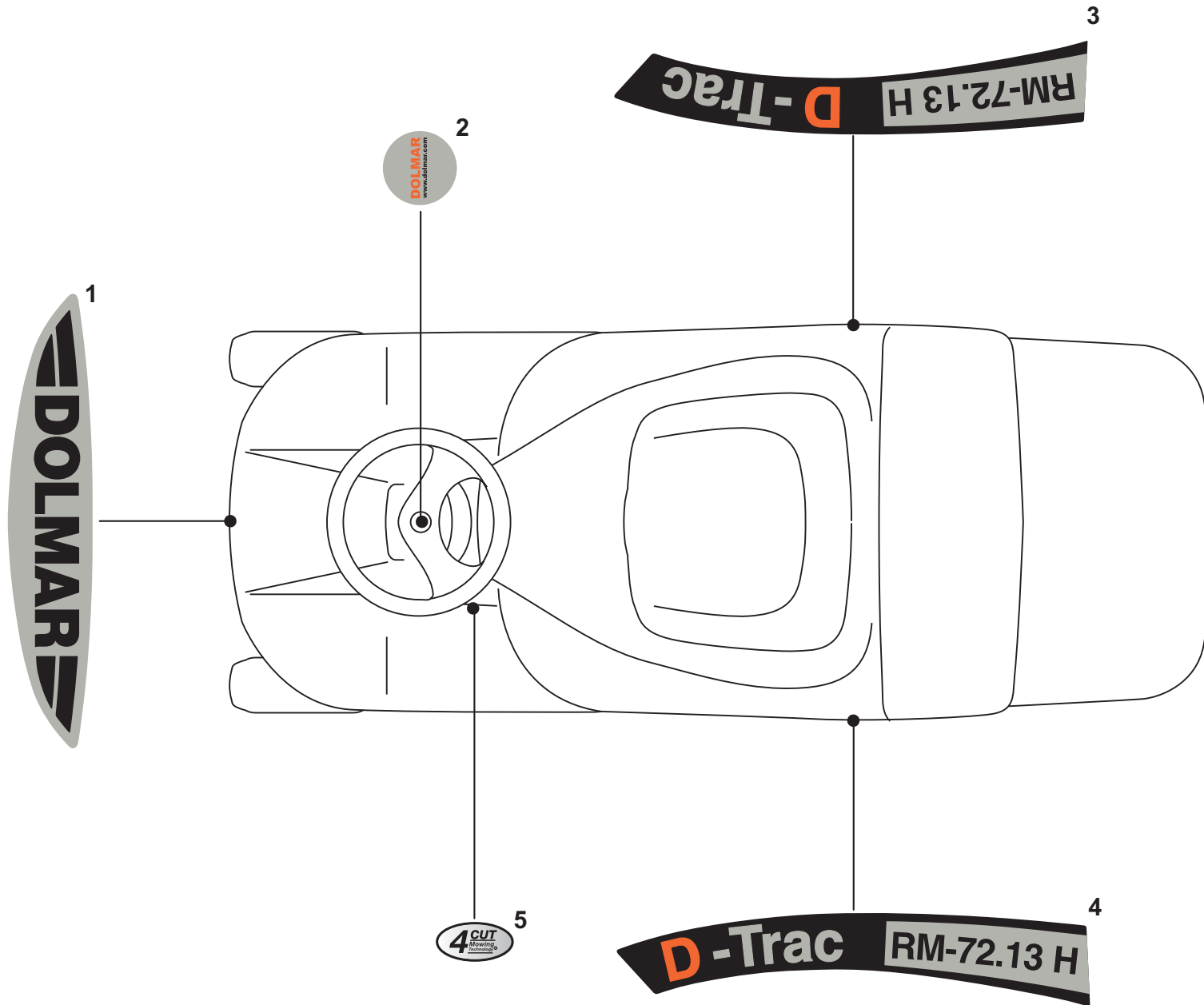

RM7213H (2015-2018)

14

AUFKLEBER
LABELS



Seite / Page	Pos.	Teil-Nr. Part No.	Hinweise Notes	Bezeichnung	Spezifikation Specification	Description
14	1	664028496		SCHILD	DOLMAR	LABEL
14	2	664361485		SCHILD	DOLMAR	LABEL
14	3	664362506		SCHILD	RM-72.13 H	LABEL
14	4	664362507		SCHILD	RM-72.13 H	LABEL
14	5	664999576		SCHILD	4 CUT	LABEL

RM7213H (2015-2018)



	Zeichenerklärung	Key to symbols
=> 1999999 2000000 => 2003.04 => TI 2003/07 Acc. = { m Corr.	Produktion bis Serien-Nr. Neues Teil ab Serien-Nr. Neues Teil ab Jahr / Monat Siehe Technische Information Jahr / Nr. Zubehör (nicht im Lieferumfang) Keine Serienausführung, jedoch verwendbar Beinhaltet Positions-Nr. Meterware Druckfehlerberichtigung	Production to serial number New part from serial number New part from Year / Month See Technical Information Year / No. Accessories (not included in the delivery inventory) No standard execution, may be used Contains item number Sold by the meter Error correction
	Änderungen vorbehalten	Specifications subject to change without notice