



Ersatzteilliste  
Spare Parts List

2015-10

PM-5175 S1 (2015)

PLM5114 (2015)

(D, GB)

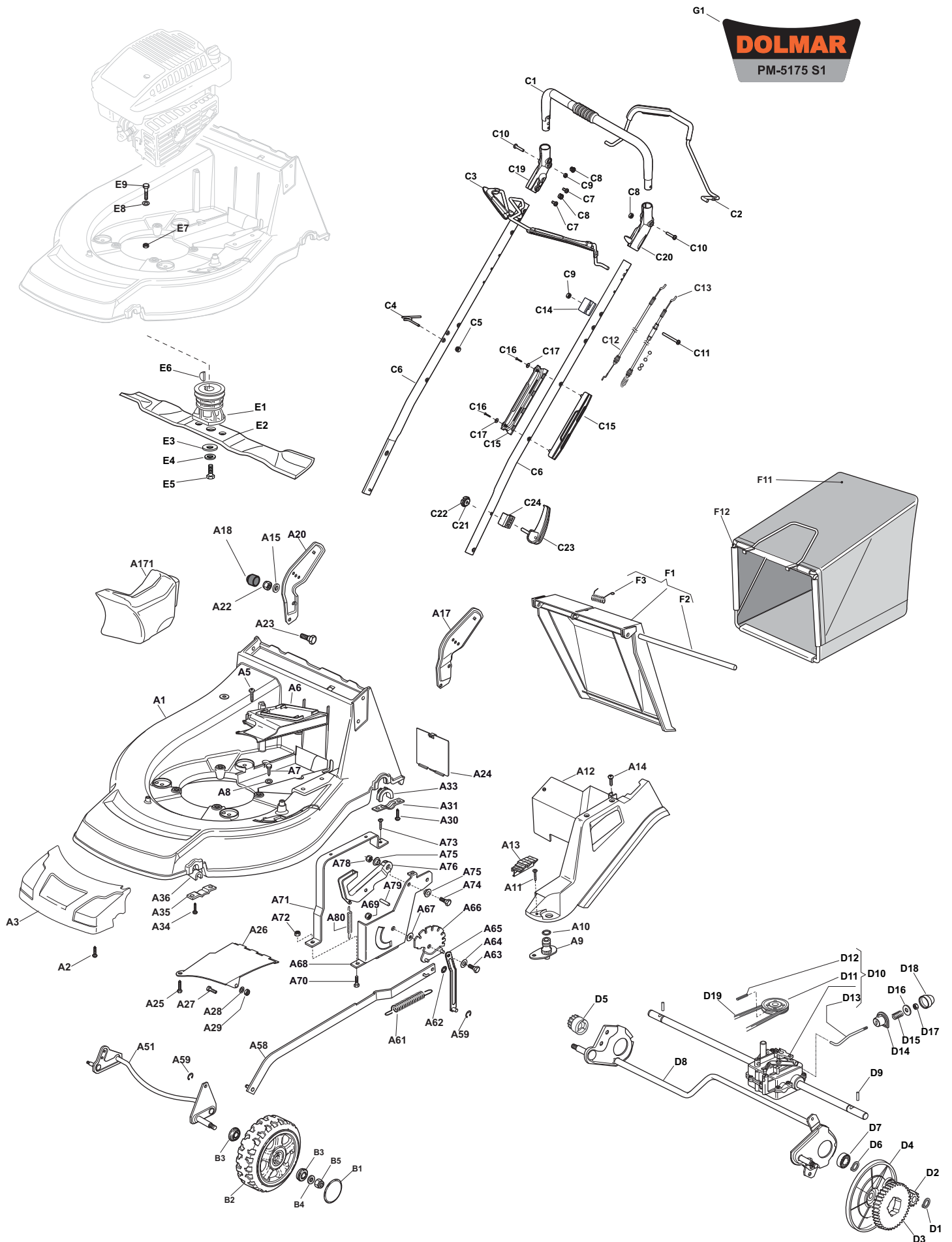



| Seite / Page | Pos.     | Teil-Nr.<br>Part No. | Hinweise<br>Notes | Bezeichnung              | Spezifikation<br>Specification | Description                    |
|--------------|----------|----------------------|-------------------|--------------------------|--------------------------------|--------------------------------|
| 1            | A1       | 1 664003546          |                   | GEHÄUSE ROT              |                                | DECK RED                       |
| 1            | A2       | 4 664735420          |                   | SCHRAUBE                 |                                | SCREW                          |
| 1            | A3       | 1 664226109          |                   | MASKE                    |                                | MASK                           |
| 1            | A5       | 2 664728522          |                   | SCHRAUBE                 |                                | SCREW                          |
| 1            | A6       | 1 664060200          |                   | SCHUTZ                   |                                | PROTECTION                     |
| 1            | A7       | 1 664729600          |                   | SCHRAUBE                 |                                | SCREW                          |
| 1            | A8       | 2 664523040          |                   | SCHEIBE                  |                                | WASHER                         |
| 1            | A9       | 1 664034000          |                   | SCHLAUCHANSCHLUSS        |                                | WASHING CONNECTION             |
| 1            | A10      | 1 664035000          |                   | O-RING                   |                                | O-RING                         |
| 1            | A11      | 3 664728519          |                   | SCHRAUBE                 |                                | SCREW                          |
| 1            | A12      | 1 664060144          |                   | GEHÄUSE                  |                                | DECK, ADJUSTMENT               |
| 1            | A13      | 1 664570200          |                   | PLATTE, HÖHENVERSTELLUNG |                                | PLATE, CUTTING POSITIONS       |
| 1            | A14      | 1 664728520          |                   | SCHRAUBE                 |                                | SCREW                          |
| 1            | A15      | 2 664521350          |                   | SCHEIBE                  |                                | WASHER                         |
| 1            | A17      | 1 664778397          |                   | HALTER, LINKS            |                                | BRACKET, LEFT                  |
| 1            | A18      | 2 664203854          |                   | ABDECKKAPPE              |                                | PROTECTION                     |
| 1            | A20      | 1 664778396          |                   | HALTER, RECHTS           |                                | BRACKET, RIGHT                 |
| 1            | A22      | 2 664155000          |                   | MUTTER                   |                                | NUT                            |
| 1            | A23      | 2 664793102          |                   | SCHRAUBE                 |                                | SCREW                          |
| 1            | A24      | 1 664595352          |                   | ABDECKPLATTE             |                                | INSPECTION DOOR                |
| 1            | A25      | 1 664729600          |                   | SCHRAUBE                 |                                | SCREW                          |
| 1            | A26      | 1 664028576          |                   | ABDECKBLECH              |                                | PLATE                          |
| 1            | A27      | 1 664789000          |                   | SCHRAUBE                 |                                | SCREW                          |
| 1            | A28      | 1 664523020          |                   | SCHEIBE                  |                                | WASHER                         |
| 1            | A29      | 1 664154330          |                   | MUTTER                   |                                | NUT                            |
| 1            | A30      | 4 664731350          |                   | SCHRAUBE                 |                                | SCREW                          |
| 1            | A31      | 2 664545147          |                   | PLATTE                   |                                | PLATE                          |
| 1            | A33      | 2 664038407          |                   | BUCHSE                   |                                | BUSH                           |
| 1            | A34      | 4 664731350          |                   | SCHRAUBE                 |                                | SCREW                          |
| 1            | A35      | 2 664545156          |                   | PLATTE                   |                                | PLATE                          |
| 1            | A36      | 2 664038400          |                   | BUCHSE                   |                                | BUSH                           |
| 1            | A51      | 1 664302865          |                   | ACHSE, VORDERRAD         |                                | AXLE, FRONT WHEELS             |
| 1            | A58      | 1 664002040          |                   | STANGE, HÖHENVERSTELLUNG |                                | ROD, HEIGHT ADJUSTMENT CONTROL |
| 1            | A59      | 2 664000930          |                   | SPRENGRING               |                                | SAFETY WASHER                  |
| 1            | A61      | 1 664446187          |                   | FEDER                    |                                | SPRING                         |
| 1            | A62      | 2 664604899          |                   | SICHERUNGSSCHEIBE        |                                | SAFETY WASHER                  |
| 1            | A63      | 1 664529662          |                   | BOLZEN                   |                                | PIN                            |
| 1            | A64      | 1 664672151          |                   | SCHEIBE                  |                                | WASHER                         |
| 1            | A65      | 1 664001269          |                   | STANGE, HINTERRADACHSE   |                                | ROD, REAR WHEELS AXLE          |
| 1            | A66      | 1 664000479          |                   | SEKTOR, HÖHENVERSTELLUNG |                                | SECTOR, HEIGHT ADJUSTMENT      |
| 1            | A67      | 1 664672152          |                   | SCHEIBE                  |                                | WASHER                         |
| 1            | A68      | 1 664785109          |                   | HALTER                   |                                | SUPPORT, HEIGHT                |
| 1            | A69      | 1 664293201          |                   | MUTTER                   |                                | NUT                            |
| 1            | A70      | 2 664793301          |                   | SCHRAUBE                 |                                | SCREW                          |
| 1            | A71      | 1 664785113          |                   | HALTER, GRIFF            |                                | SUPPORT, HANDLE                |
| 1            | A72      | 2 664293201          |                   | MUTTER                   |                                | NUT                            |
| 1            | A73      | 1 664729600          |                   | SCHRAUBE                 |                                | SCREW                          |
| 1            | A74      | 1 664793301          |                   | SCHRAUBE                 |                                | SCREW                          |
| 1            | A75      | 2 664038002          |                   | BUCHSE                   |                                | BUSH                           |
| 1            | A76      | 1 664393611          |                   | GRIFF                    |                                | KNOB                           |
| 1            | A78      | 1 664293201          |                   | MUTTER                   |                                | NUT                            |
| 1            | A79      | 1 664622640          |                   | STIFT                    |                                | PIN                            |
| 1            | A80      | 1 664446175          |                   | FEDER                    |                                | SPRING                         |
| 1            | A17<br>1 | 1 664140224          |                   | MULCHKEIL                | 48/53 CM                       | MULCH PLUG                     |
| 1            | B1       | 4 664110653          |                   | RADKAPPE                 |                                | WHEEL COVER                    |
| 1            | B2       | 4 664007487          |                   | RAD                      | Ø 210                          | WHEEL                          |
| 1            | B3       | 8 664216035          |                   | LAGER                    |                                | BEARING                        |
| 1            | B4       | 4 664521350          |                   | SCHEIBE                  |                                | WASHER                         |
| 1            | B5       | 4 664155000          |                   | MUTTER                   |                                | NUT                            |
| 1            | C1       | 1 664006670          |                   | HANDGRIFF                |                                | HANDGRIP                       |
| 1            | C2       | 1 664003349          |                   | HEBEL, ANTRIEB           |                                | LEVER, DRIVING                 |
| 1            | C3       | 1 664003344          |                   | HEBEL, MOTORBREMSE       |                                | LEVER, MOTOR BRAKE             |
| 1            | C4       | 1 664430309          |                   | FEDERFÜHRUNG             |                                | GUIDE SPRING                   |

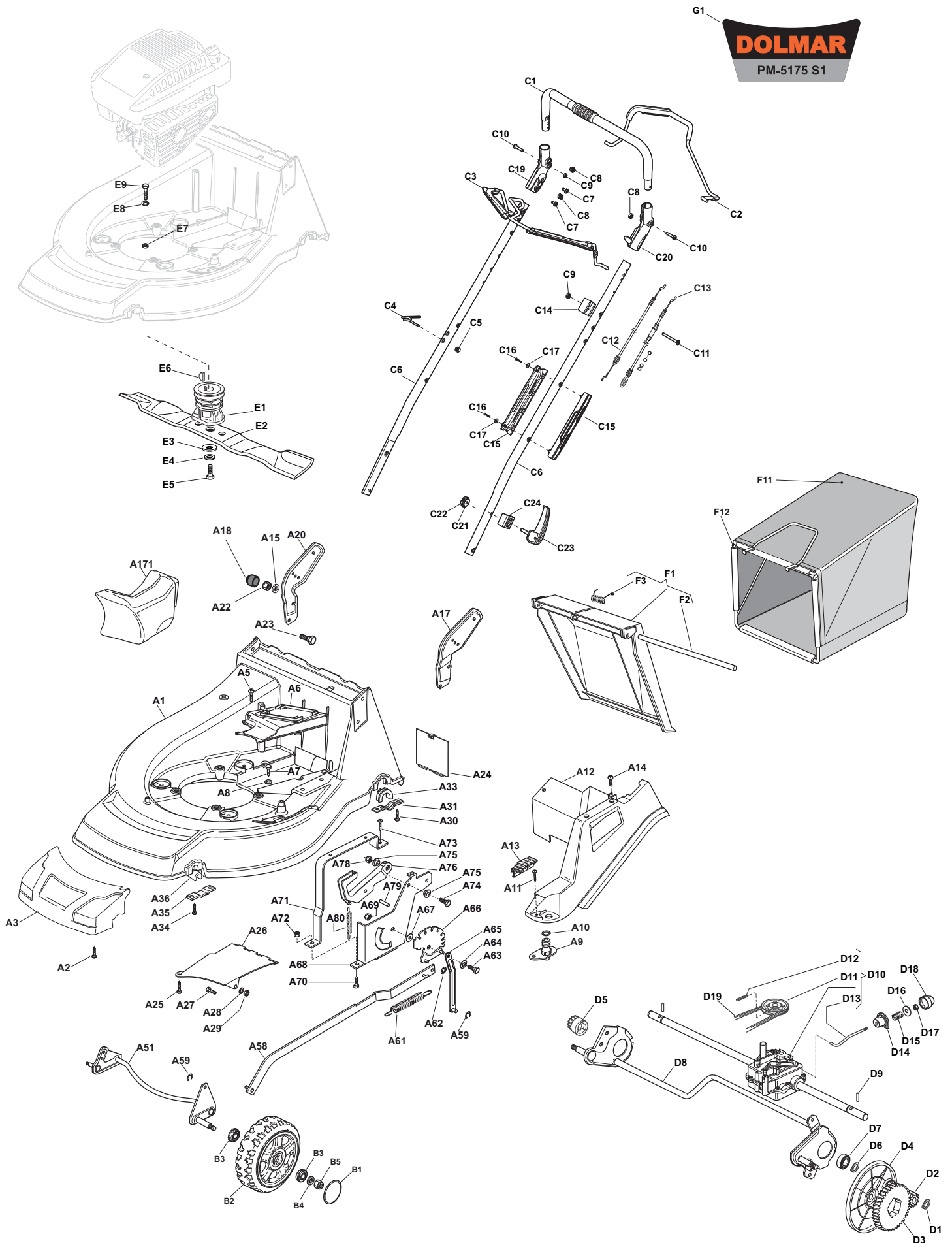

| Seite / Page | Pos. | Teil-Nr.<br>Part No. | Hinweise<br>Notes | Bezeichnung            | Spezifikation<br>Specification | Description                      |
|--------------|------|----------------------|-------------------|------------------------|--------------------------------|----------------------------------|
| 1            | C5   | 1 664154330          |                   | MUTTER                 |                                | NUT                              |
| 1            | C6   | 2 664007046          |                   | HOLM                   | BLACK                          | HANDLE                           |
| 1            | C7   | 4 664735662          |                   | SCHRAUBE               |                                | SCREW                            |
| 1            | C8   | 4 664041967          |                   | BUCHSE                 |                                | BUSH                             |
| 1            | C9   | 3 664154510          |                   | MUTTER                 |                                | NUT                              |
| 1            | C10  | 2 664728721          |                   | SCHRAUBE               |                                | SCREW                            |
| 1            | C11  | 1 664727784          |                   | SCHRAUBE               |                                | SCREW                            |
| 1            | C12  | 1 664030101          |                   | BOWDENZUG, MOTORBREMSE |                                | BOWDEN CABLE, THREAD MOTOR BRAKE |
| 1            | C13  | 1 664030098          |                   | BOWDENZUG, ANTRIEB     |                                | BOWDEN CABLE, REAR DRIVE         |
| 1            | C14  | 1 664551639          |                   | KABELHALTER            |                                | CABLE HOLDER                     |
| 1            | C15  | 2 664806644          |                   | SCHUTZ                 |                                | PROTECTION                       |
| 1            | C16  | 2 664727812          |                   | SCHRAUBE               |                                | SCREW                            |
| 1            | C17  | 2 664523000          |                   | SCHEIBE                |                                | WASHER                           |
| 1            | C19  | 1 664488301          |                   | HALTER, RECHTS         |                                | SUPPORT, R                       |
| 1            | C20  | 1 664488303          |                   | HALTER, LINKS          |                                | SUPPORT, L                       |
| 1            | C21  | 2 664131750          |                   | MUTTER                 |                                | NUT                              |
| 1            | C22  | 2 664399835          |                   | GRIFF                  |                                | GRIP                             |
| 1            | C23  | 2 664003253          |                   | GRIFF                  |                                | HANDLE                           |
| 1            | C24  | 2 664680017          |                   | HALTER                 |                                | SUPPORT                          |
| 1            | D1   | 2 664608600          |                   | SICHERUNGSRING         |                                | SEEGER                           |
| 1            | D2   | 1 664570120          |                   | RITZEL LINKS           |                                | PINION L                         |
| 1            | D3   | 2 664120105          |                   | ZAHNRAD                |                                | RING GEAR                        |
| 1            | D4   | 2 664600268          |                   | SCHUTZABDECKUNG        |                                | PROTECTION                       |
| 1            | D5   | 1 664570110          |                   | RITZEL RECHTS          |                                | PINION RIGHT                     |
| 1            | D6   | 2 664608600          |                   | SICHERUNGSRING         |                                | SEEGER                           |
| 1            | D7   | 2 664216035          |                   | LAGER                  |                                | BEARING                          |
| 1            | D8   | 1 664302867          |                   | ACHSE, HINTERRAD       |                                | AXLE, REAR WHEELS                |
| 1            | D9   | 2 664753000          |                   | STIFT                  |                                | PIN                              |
| 1            | D10  | 1 664003079          |                   | ANTRIEB                | (FRANCE<br>REDUCTEURS)         | GEAR BOX                         |
| 1            | D11  | 1 664601909          |                   | RIEMENSCHLEIFE         |                                | PULLEY                           |
| 1            | D12  | 1 664645705          |                   | STIFT                  |                                | PIN                              |
| 1            | D13  | 1 664033281          |                   | VERSTELLHEBEL          |                                | ADJUSTMENT ROD                   |
| 1            | D14  | 1 664041957          |                   | BUCHSE                 |                                | BUSH                             |
| 1            | D15  | 1 664450063          |                   | FEDER                  |                                | SPRING                           |
| 1            | D16  | 1 664680009          |                   | SCHEIBE                |                                | WASHER                           |
| 1            | D17  | 1 664154510          |                   | MUTTER                 |                                | NUT                              |
| 1            | D18  | 1 664110230          |                   | NABENDECKEL            |                                | HUB COVER                        |
| 1            | D19  | 1 664064195          |                   | KEILRIEMEN             | Z 33 (9,5 x 845)               | BELT                             |
| 1            | E1   | 1 664465607          |                   | MESSERHALTER           |                                | HUB                              |
| 1            | E2   | 1 664004381          |                   | MULCHMESSER            |                                | BLADE (COLLECT AND MULCH)        |
| 1            | E3   | 1 664160400          |                   | FEDERSCHLEIFE          |                                | ELASTIC WASHER                   |
| 1            | E4   | 1 664523080          |                   | SCHEIBE                |                                | WASHER                           |
| 1            | E5   | 1 664735698          |                   | SCHRAUBE               |                                | SCREW                            |
| 1            | E6   | 1 664139100          |                   | KEIL                   |                                | KEY                              |
| 1            | E7   | 3 664155000          |                   | MUTTER                 |                                | NUT                              |
| 1            | E8   | 3 664521350          |                   | SCHEIBE                |                                | WASHER                           |
| 1            | E9   | 3 664691900          |                   | SCHRAUBE               |                                | SCREW                            |
| 1            | F1   | 1 664008114          |                   | PRALLBLECH             |                                | STONE-GUARD                      |
| 1            | F2   | 1 664517881          |                   | BOLZEN                 |                                | PIN                              |
| 1            | F3   | 1 664450270          |                   | FEDER                  |                                | SPRING                           |
| 1            | F11  | 1 664002124          |                   | SACK, TUCH             | neutral                        | BOX, FABRIC                      |
| 1            | F12  | 1 664006430          |                   | RAHMEN                 |                                | FRAME                            |
| 1            | G1   | 1 664365733          |                   | SCHILD                 | PM-5175 S1                     | LABEL                            |

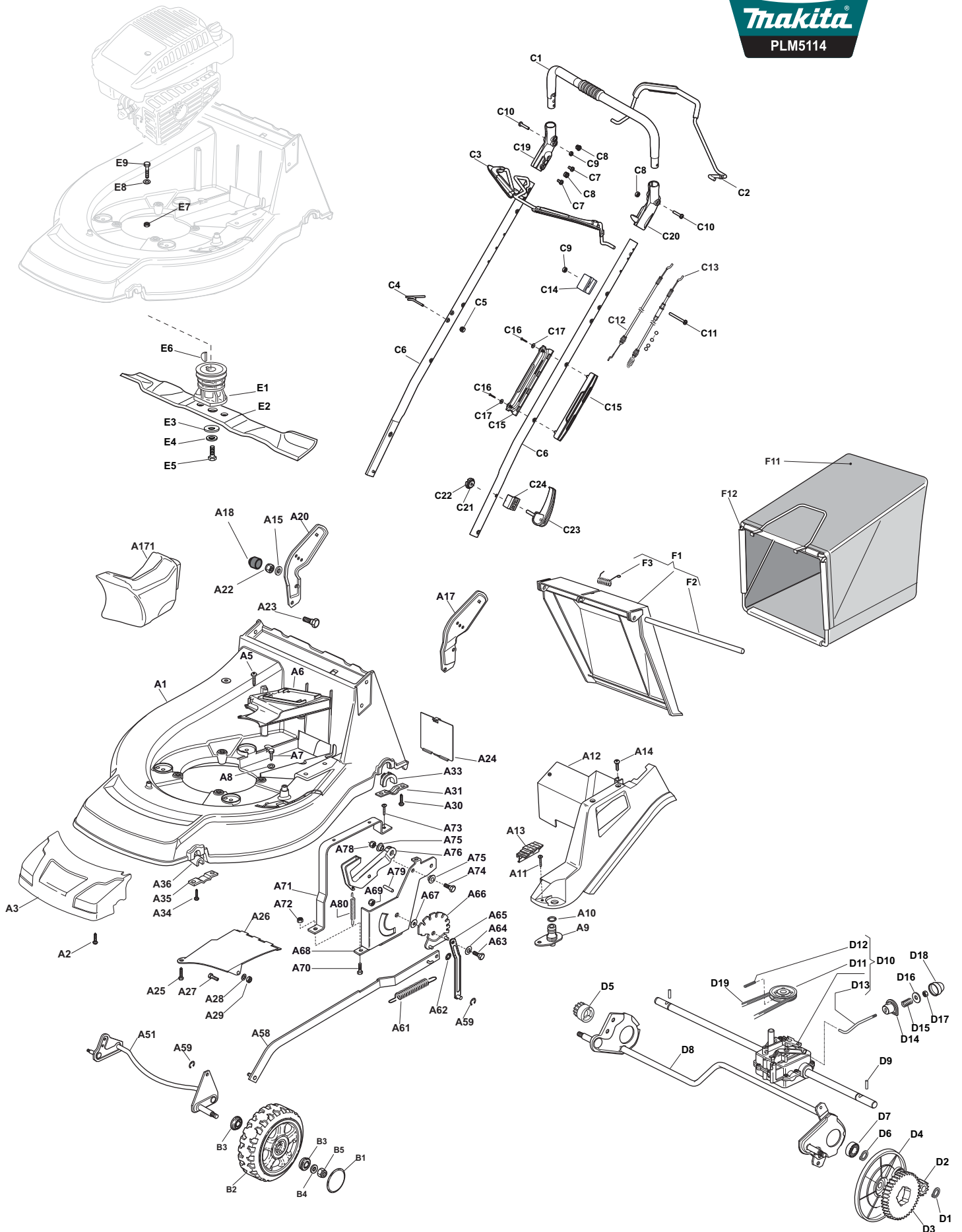



| Seite / Page | Pos.     | PLM5114 (2015) | Teil-Nr.<br>Part No. | Hinweise<br>Notes | Bezeichnung              | Spezifikation<br>Specification | Description                    |
|--------------|----------|----------------|----------------------|-------------------|--------------------------|--------------------------------|--------------------------------|
| 2            | A1       | 1              | 664003516            |                   | GEHÄUSE BLAU             |                                | DECK BLUE                      |
| 2            | A2       | 4              | 664735420            |                   | SCHRAUBE                 |                                | SCREW                          |
| 2            | A3       | 1              | 664226109            |                   | MASKE                    |                                | MASK                           |
| 2            | A5       | 2              | 664728522            |                   | SCHRAUBE                 |                                | SCREW                          |
| 2            | A6       | 1              | 664060200            |                   | SCHUTZ                   |                                | PROTECTION                     |
| 2            | A7       | 1              | 664729600            |                   | SCHRAUBE                 |                                | SCREW                          |
| 2            | A8       | 2              | 664523040            |                   | SCHEIBE                  |                                | WASHER                         |
| 2            | A9       | 1              | 664034000            |                   | SCHLAUCHANSCHLUSS        |                                | WASHING CONNECTION             |
| 2            | A10      | 1              | 664035000            |                   | O-RING                   |                                | O-RING                         |
| 2            | A11      | 3              | 664728519            |                   | SCHRAUBE                 |                                | SCREW                          |
| 2            | A12      | 1              | 664060144            |                   | GEHÄUSE                  |                                | DECK, ADJUSTMENT               |
| 2            | A13      | 1              | 664570200            |                   | PLATTE, HÖHENVERSTELLUNG |                                | PLATE, CUTTING POSITIONS       |
| 2            | A14      | 1              | 664728520            |                   | SCHRAUBE                 |                                | SCREW                          |
| 2            | A15      | 2              | 664521350            |                   | SCHEIBE                  |                                | WASHER                         |
| 2            | A17      | 1              | 664778397            |                   | HALTER, LINKS            |                                | BRACKET, LEFT                  |
| 2            | A18      | 2              | 664203854            |                   | ABDECKKAPPE              |                                | PROTECTION                     |
| 2            | A20      | 1              | 664778396            |                   | HALTER, RECHTS           |                                | BRACKET, RIGHT                 |
| 2            | A22      | 2              | 664155000            |                   | MUTTER                   |                                | NUT                            |
| 2            | A23      | 2              | 664793102            |                   | SCHRAUBE                 |                                | SCREW                          |
| 2            | A24      | 1              | 664595352            |                   | ABDECKPLATTE             |                                | INSPECTION DOOR                |
| 2            | A25      | 1              | 664729600            |                   | SCHRAUBE                 |                                | SCREW                          |
| 2            | A26      | 1              | 664028576            |                   | ABDECKBLECH              |                                | PLATE                          |
| 2            | A27      | 1              | 664789000            |                   | SCHRAUBE                 |                                | SCREW                          |
| 2            | A28      | 1              | 664523020            |                   | SCHEIBE                  |                                | WASHER                         |
| 2            | A29      | 1              | 664154330            |                   | MUTTER                   |                                | NUT                            |
| 2            | A30      | 4              | 664731350            |                   | SCHRAUBE                 |                                | SCREW                          |
| 2            | A31      | 2              | 664545147            |                   | PLATTE                   |                                | PLATE                          |
| 2            | A33      | 2              | 664038407            |                   | BUCHSE                   |                                | BUSH                           |
| 2            | A34      | 4              | 664731350            |                   | SCHRAUBE                 |                                | SCREW                          |
| 2            | A35      | 2              | 664545156            |                   | PLATTE                   |                                | PLATE                          |
| 2            | A36      | 2              | 664038400            |                   | BUCHSE                   |                                | BUSH                           |
| 2            | A51      | 1              | 664302865            |                   | ACHSE, VORDERRAD         |                                | AXLE, FRONT WHEELS             |
| 2            | A58      | 1              | 664002040            |                   | STANGE, HÖHENVERSTELLUNG |                                | ROD, HEIGHT ADJUSTMENT CONTROL |
| 2            | A59      | 2              | 664000930            |                   | SPRENGRING               |                                | SAFETY WASHER                  |
| 2            | A61      | 1              | 664446187            |                   | FEDER                    |                                | SPRING                         |
| 2            | A62      | 2              | 664604899            |                   | SICHERUNGSSCHEIBE        |                                | SAFETY WASHER                  |
| 2            | A63      | 1              | 664529662            |                   | BOLZEN                   |                                | PIN                            |
| 2            | A64      | 1              | 664672151            |                   | SCHEIBE                  |                                | WASHER                         |
| 2            | A65      | 1              | 664001269            |                   | STANGE, HINTERRADACHSE   |                                | ROD, REAR WHEELS AXLE          |
| 2            | A66      | 1              | 664000479            |                   | SEKTOR, HÖHENVERSTELLUNG |                                | SECTOR, HEIGHT ADJUSTMENT      |
| 2            | A67      | 1              | 664672152            |                   | SCHEIBE                  |                                | WASHER                         |
| 2            | A68      | 1              | 664785109            |                   | HALTER                   |                                | SUPPORT, HEIGHT                |
| 2            | A69      | 1              | 664293201            |                   | MUTTER                   |                                | NUT                            |
| 2            | A70      | 2              | 664793301            |                   | SCHRAUBE                 |                                | SCREW                          |
| 2            | A71      | 1              | 664785113            |                   | HALTER, GRIFF            |                                | SUPPORT, HANDLE                |
| 2            | A72      | 2              | 664293201            |                   | MUTTER                   |                                | NUT                            |
| 2            | A73      | 1              | 664729600            |                   | SCHRAUBE                 |                                | SCREW                          |
| 2            | A74      | 1              | 664793301            |                   | SCHRAUBE                 |                                | SCREW                          |
| 2            | A75      | 2              | 664038002            |                   | BUCHSE                   |                                | BUSH                           |
| 2            | A76      | 1              | 664393611            |                   | GRIFF                    |                                | KNOB                           |
| 2            | A78      | 1              | 664293201            |                   | MUTTER                   |                                | NUT                            |
| 2            | A79      | 1              | 664622640            |                   | STIFT                    |                                | PIN                            |
| 2            | A80      | 1              | 664446175            |                   | FEDER                    |                                | SPRING                         |
| 2            | A17<br>1 | 1              | 664140224            |                   | MULCHKEIL                | 48/53 CM                       | MULCH PLUG                     |
| 2            | B1       | 4              | 664110653            |                   | RADKAPPE                 |                                | WHEEL COVER                    |
| 2            | B2       | 4              | 664007487            |                   | RAD                      | Ø 210                          | WHEEL                          |
| 2            | B3       | 8              | 664216035            |                   | LAGER                    |                                | BEARING                        |
| 2            | B4       | 4              | 664521350            |                   | SCHEIBE                  |                                | WASHER                         |
| 2            | B5       | 4              | 664155000            |                   | MUTTER                   |                                | NUT                            |
| 2            | C1       | 1              | 664006670            |                   | HANDGRIFF                |                                | HANDGRIP                       |
| 2            | C2       | 1              | 664003349            |                   | HEBEL, ANTRIEB           |                                | LEVER, DRIVING                 |
| 2            | C3       | 1              | 664003344            |                   | HEBEL, MOTORBREMSE       |                                | LEVER, MOTOR BRAKE             |
| 2            | C4       | 1              | 664430309            |                   | FEDERFÜHRUNG             |                                | GUIDE SPRING                   |

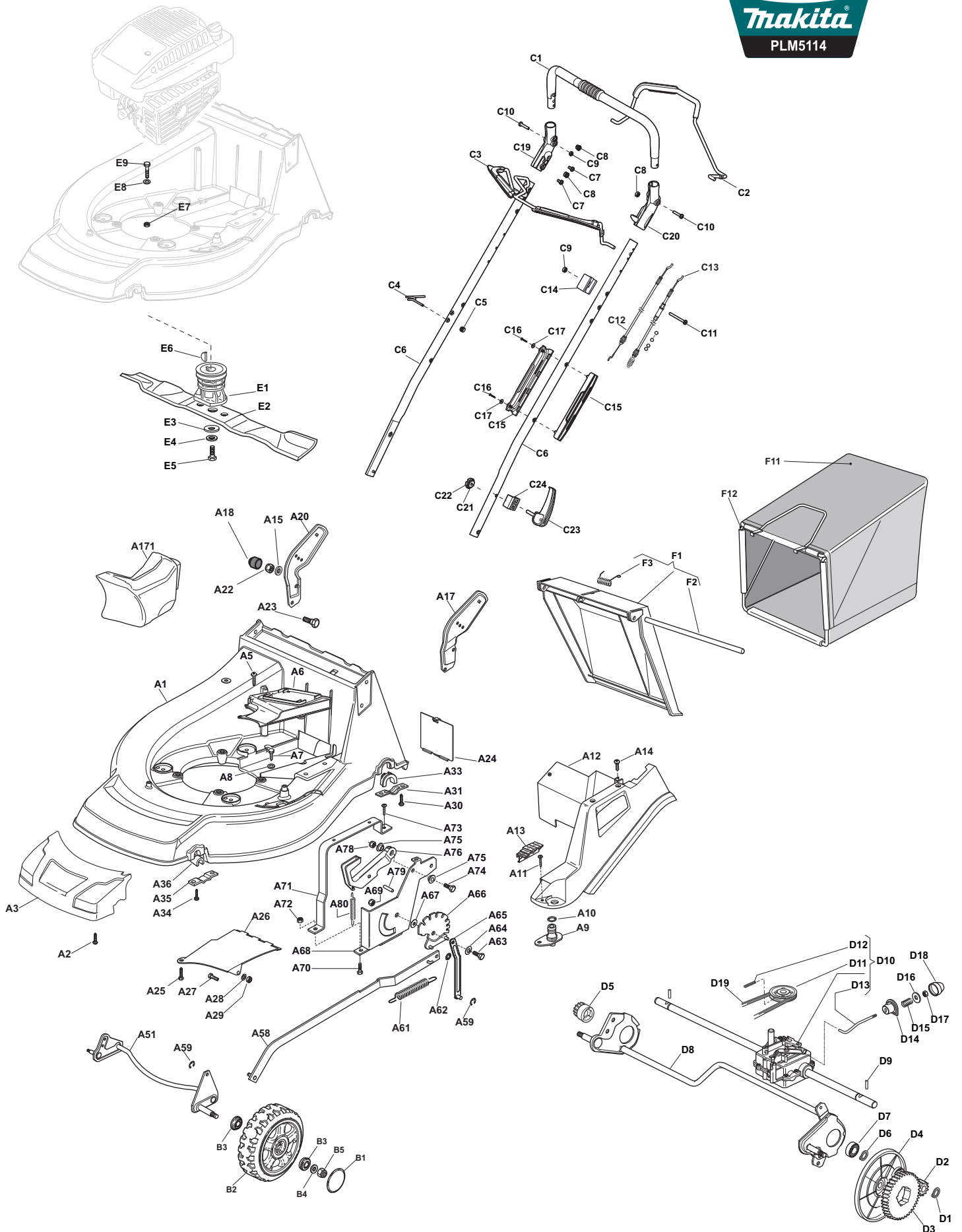



| Seite / Page | Pos. | PLM5114 (2015) | Teil-Nr.<br>Part No. | Hinweise<br>Notes | Bezeichnung            | Spezifikation<br>Specification | Description                      |
|--------------|------|----------------|----------------------|-------------------|------------------------|--------------------------------|----------------------------------|
| 2            | C5   | 1              | 664154330            |                   | MUTTER                 |                                | NUT                              |
| 2            | C6   | 2              | 664007046            |                   | HOLM                   | BLACK                          | HANDLE                           |
| 2            | C7   | 4              | 664735662            |                   | SCHRAUBE               |                                | SCREW                            |
| 2            | C8   | 4              | 664041967            |                   | BUCHSE                 |                                | BUSH                             |
| 2            | C9   | 3              | 664154510            |                   | MUTTER                 |                                | NUT                              |
| 2            | C10  | 2              | 664728721            |                   | SCHRAUBE               |                                | SCREW                            |
| 2            | C11  | 1              | 664727784            |                   | SCHRAUBE               |                                | SCREW                            |
| 2            | C12  | 1              | 664030101            |                   | BOWDENZUG, MOTORBREMSE |                                | BOWDEN CABLE, THREAD MOTOR BRAKE |
| 2            | C13  | 1              | 664030098            |                   | BOWDENZUG, ANTRIEB     |                                | BOWDEN CABLE, REAR DRIVE         |
| 2            | C14  | 1              | 664551639            |                   | KABELHALTER            |                                | CABLE HOLDER                     |
| 2            | C15  | 2              | 664806644            |                   | SCHUTZ                 |                                | PROTECTION                       |
| 2            | C16  | 2              | 664727812            |                   | SCHRAUBE               |                                | SCREW                            |
| 2            | C17  | 2              | 664523000            |                   | SCHEIBE                |                                | WASHER                           |
| 2            | C19  | 1              | 664488301            |                   | HALTER, RECHTS         |                                | SUPPORT, R                       |
| 2            | C20  | 1              | 664488303            |                   | HALTER, LINKS          |                                | SUPPORT, L                       |
| 2            | C21  | 2              | 664131750            |                   | MUTTER                 |                                | NUT                              |
| 2            | C22  | 2              | 664399835            |                   | GRIFF                  |                                | GRIP                             |
| 2            | C23  | 2              | 664003253            |                   | GRIFF                  |                                | HANDLE                           |
| 2            | C24  | 2              | 664680017            |                   | HALTER                 |                                | SUPPORT                          |
| 2            | D1   | 2              | 664608600            |                   | SICHERUNGSRING         |                                | SEEGER                           |
| 2            | D2   | 1              | 664570120            |                   | RITZEL LINKS           |                                | PINION L                         |
| 2            | D3   | 2              | 664120105            |                   | ZAHNRAD                |                                | RING GEAR                        |
| 2            | D4   | 2              | 664600268            |                   | SCHUTZABDECKUNG        |                                | PROTECTION                       |
| 2            | D5   | 1              | 664570110            |                   | RITZEL RECHTS          |                                | PINION RIGHT                     |
| 2            | D6   | 2              | 664608600            |                   | SICHERUNGSRING         |                                | SEEGER                           |
| 2            | D7   | 2              | 664216035            |                   | LAGER                  |                                | BEARING                          |
| 2            | D8   | 1              | 664302867            |                   | ACHSE, HINTERRAD       |                                | AXLE, REAR WHEELS                |
| 2            | D9   | 2              | 664753000            |                   | STIFT                  |                                | PIN                              |
| 2            | D10  | 1              | 664003079            |                   | ANTRIEB                | (FRANCE<br>REDUCTEURS)         | GEAR BOX                         |
| 2            | D11  | 1              | 664601909            |                   | RIEMENSCHLEIBE         |                                | PULLEY                           |
| 2            | D12  | 1              | 664645705            |                   | STIFT                  |                                | PIN                              |
| 2            | D13  | 1              | 664033281            |                   | VERSTELLHEBEL          |                                | ADJUSTMENT ROD                   |
| 2            | D14  | 1              | 664041957            |                   | BUCHSE                 |                                | BUSH                             |
| 2            | D15  | 1              | 664450063            |                   | FEDER                  |                                | SPRING                           |
| 2            | D16  | 1              | 664680009            |                   | SCHEIBE                |                                | WASHER                           |
| 2            | D17  | 1              | 664154510            |                   | MUTTER                 |                                | NUT                              |
| 2            | D18  | 1              | 664110230            |                   | NABENDECKEL            |                                | HUB COVER                        |
| 2            | D19  | 1              | 664064195            |                   | KEILRIEMEN             | Z 33 (9,5 x 845)               | BELT                             |
| 2            | E1   | 1              | 664465607            |                   | MESSERHALTER           |                                | HUB                              |
| 2            | E2   | 1              | 664004381            |                   | MULCHMESSER            |                                | BLADE (COLLECT AND MULCH)        |
| 2            | E3   | 1              | 664160400            |                   | FEDERSCHLEIBE          |                                | ELASTIC WASHER                   |
| 2            | E4   | 1              | 664523080            |                   | SCHEIBE                |                                | WASHER                           |
| 2            | E5   | 1              | 664735698            |                   | SCHRAUBE               |                                | SCREW                            |
| 2            | E6   | 1              | 664139100            |                   | KEIL                   |                                | KEY                              |
| 2            | E7   | 3              | 664155000            |                   | MUTTER                 |                                | NUT                              |
| 2            | E8   | 3              | 664521350            |                   | SCHEIBE                |                                | WASHER                           |
| 2            | E9   | 3              | 664691900            |                   | SCHRAUBE               |                                | SCREW                            |
| 2            | F1   | 1              | 664008114            |                   | PRALLBLECH             |                                | STONE-GUARD                      |
| 2            | F2   | 1              | 664517881            |                   | BOLZEN                 |                                | PIN                              |
| 2            | F3   | 1              | 664450270            |                   | FEDER                  |                                | SPRING                           |
| 2            | F11  | 1              | 664002124            |                   | SACK, TUCH             | neutral                        | BOX, FABRIC                      |
| 2            | F12  | 1              | 664006430            |                   | RAHMEN                 |                                | FRAME                            |
| 2            | G1   | 1              | 664365737            |                   | SCHILD                 | PLM5114                        | LABEL                            |

PM-5175 S1 (2015), PLM5114  
(2015)



**1** PM-5175 S1  
PM-5175 S1

**2** PLM5114  
PLM5114

|  | <b>Zeichenerklärung</b>  | <b>Key to symbols</b>   |
|--|--|---|
| <b>=&gt; 1999999</b><br><b>2000000 =&gt;</b><br><b>2003.04 =&gt;</b><br><b>TI 2003/07</b><br><b>Acc.</b><br><b>=</b><br><b>{</b><br><b>m</b><br><b>Corr.</b> | Produktion bis Serien-Nr.<br>Neues Teil ab Serien-Nr.<br>Neues Teil ab Jahr / Monat<br>Siehe Technische Information Jahr / Nr.<br>Zubehör (nicht im Lieferumfang)<br>Keine Serienausführung, jedoch verwendbar<br>Beinhaltet Positions-Nr.<br>Meterware<br>Druckfehlerberichtigung | Production to serial number<br>New part from serial number<br>New part from Year / Month<br>See Technical Information Year / No.<br>Accessories (not included in the delivery inventory)<br>No standard execution, may be used<br>Contains item number<br>Sold by the meter<br>Error correction |
|  | Änderungen vorbehalten   | Specifications subject to change without notice   |