

Spare Parts List
Ersatzteilliste
Liste de pièces détachées
Lista de piezas de repuesto

2015-03

MS-341 U

DOLMAR



A member of the *Makita* Group

MS-341 U (D, GB, F, E)

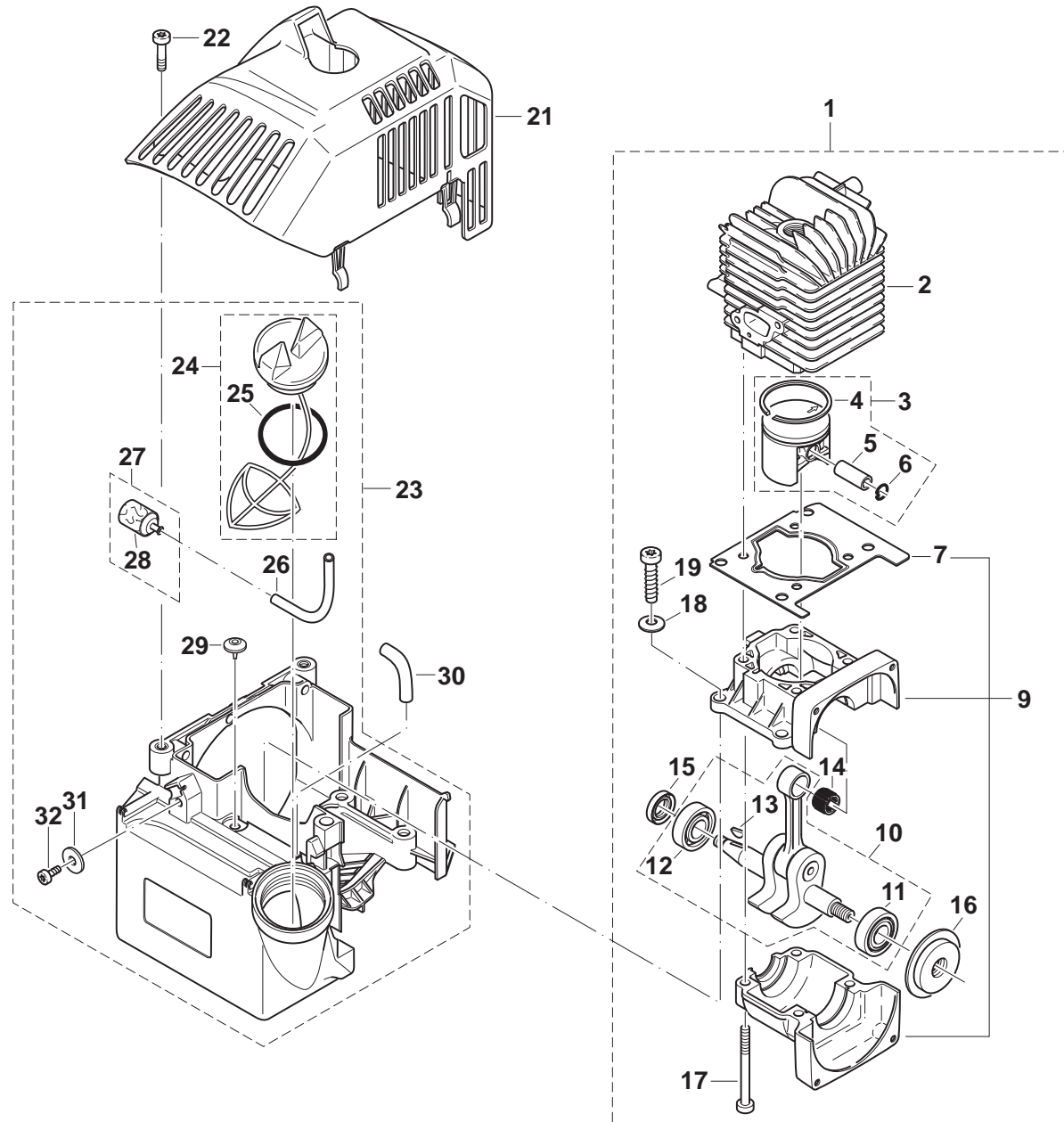

MS-341 U

1

Zylinder, Kurbeltrieb, Gehäuse
Cylinder, crankshaft, crankcase
Cylindre, vilebrequin, carter-vilebrequin
Cilindro, cigüeñal, carter cigüeñal

DOLMAR
A member of the **Takita** Group

Seite / Page	Pos.	MS-341 U	Teil-Nr. Part No. No. de pièce No. de pieza	Hinweise Notes Renseign. Nota	Bezeichnung	Spezifikation Specification	Description	Désignation	Denominación
1	1	1	384 100 100		SHORTBLOCK	33 cm ³ INC. 2,3,9,10,14-19	SHORT BLOCK	SHORT BLOCK	SHORT BLOCK
1	2	1	384 131 012		ZYLINDER	ø 37mm	CYLINDER	CYLINDRE	CILINDRO
1	3	1	957 132 384		KOLBEN KPL.	ø 37mm INC. 4-6	PISTON ASSY.	PISTON CPL.	PISTÓN CPL.
1	4	1	021 132 030		KOLBENRING	ø 37mm	PISTON RING	SEGMENT DE PISTON	SEGMENT DE PISTÓN
1	5	1	385 132 030		KOLBENBOLZEN		PISTON PIN	AXE DE PISTON	AXE DE PISTÓN
1	6	2	385 132 040		SPRENGRING		SPRING RING	ANNEAU RESSORT	ANILO ELASTICO
1	7	1	385 131 030		DICHTUNG		GASKET	JOINT	JUNTA
1	9	1	385 111 102		KURBELGEHÄUSE KPL. SATZ	INC. 7	CRANKCASE ASSY.	CARTER VILEBREQUIN CPL.	CARTER CIGÜENAL CPL.
1	10	1	385 120 100		KURBELWELLE KPL.	INC. 11-13	CRANKSHAFT ASSY.	VILEBREQUIN CPL.	CIGÜENAL CPL.
1	11	1	960 102 131		KUGELLAGER	6201	BALL BEARING	ROULEMENT À BILLES	RODAMIENTO DE BOLAS
1	12	1	960 102 131		KUGELLAGER	6201	BALL BEARING	ROULEMENT À BILLES	RODAMIENTO DE BOLAS
1	13	1	939 620 371		SCHEIBENFEDER		KEY	CLAVETTE	CHAVETA
1	14	1	962 211 033		NADELKÄFIG		NEEDLE CAGE	CAGE À AIGUILLES	JAULA DE AGUJAS
1	15	1	962 900 057		RADIALDICHTUNG		RADIAL RING	JOINT RADIAL	JUNTA RADIAL
1	16	1	962 900 060		RADIALDICHTUNG		RADIAL RING	JOINT RADIAL	ANILLO RADIAL
1	17	4	908 505 555		SCHRAUBE INNEN6RD ZK	M5x55	H.L. SOCKET HEAD BOLT	VIS	TORNILLO
1	18	4	928 014 000		TELLERFEDER		CUP SPRING	RESSORT À DISQUES	RESORTE DE DISCO
1	19	4	913 467 304		INNENSTERN-SCHRAUBE		SCREW	VIS	TORNILLO
1	21	1	387 118 312		HAUBE	RED	HOOD	CAPOT	TAPA PROTECTORA
1	22	2	908 605 205		SCHRAUBE INNEN6RD	M5x20	H.L. SOCKET HEAD BOLT	VIS	TORNILLO
1	23	1	387 110 340		MOTORTRÄGER KPL.	INC. 24,26,27,29,31,32	MOTOR HOUSING CPL.	CARTER DU MOTEUR CPL.	CARTER DE MOTOR CPL.
1	24	1	010 114 091		TANKDECKEL KPL., KRAFTSTOFF	INC. 25	TANK CAP CPL.	BOUCHON RÉSERVOIR CPL.	CIERRE DEPÓSITO CPL.
1	25	1	963 230 031		O-RING, ROT	ø30x3	O-RING, RED	BAGUE JOINT, ROUGE	ANILLO DE GUARNICIÓN, ROJO
1	26	m	965 452 382		SCHLAUCH	5,5X3 L=1000MM 100 mm	TUBE	GAINÉ	TUBO
1	27	1	010 114 010		SAUGKOPF KPL.	INC. 28	SUCTION HEAD	TETE D'ASPIRATION	CABEZA DE ASPIRACION
1	28	1	010 114 020		REPARATUR-SATZ, FILTER (JE 5 STCK.)	for 010114010	REP. KIT, FILTER (5 OF EACH)	JEU DE RÉPARAT., FILTRE	JUEGO DE REPARAR, FILTRO
1	29	1	965 404 222		BELÜFTUNGSVENTIL		AIR VALVE	SOUPAPE D'AERATION	VÁLVULA VENTILACION
1	30	m	965 452 470		KRAFTSTOFFLEITUNG	43 mm	FUEL LINE	CONDUITE CARB.	CONDUCTO COMBU.
1	31	1	924 905 300		KOTFLÜGELSCHEIBE		DISC	DISQUE	DISCO
1	32	1	913 447 134		SCHRAUBE INNEN6RD ZK K	4,7x13	H.L. TAPPING SCREW	VIS	TORNILLO

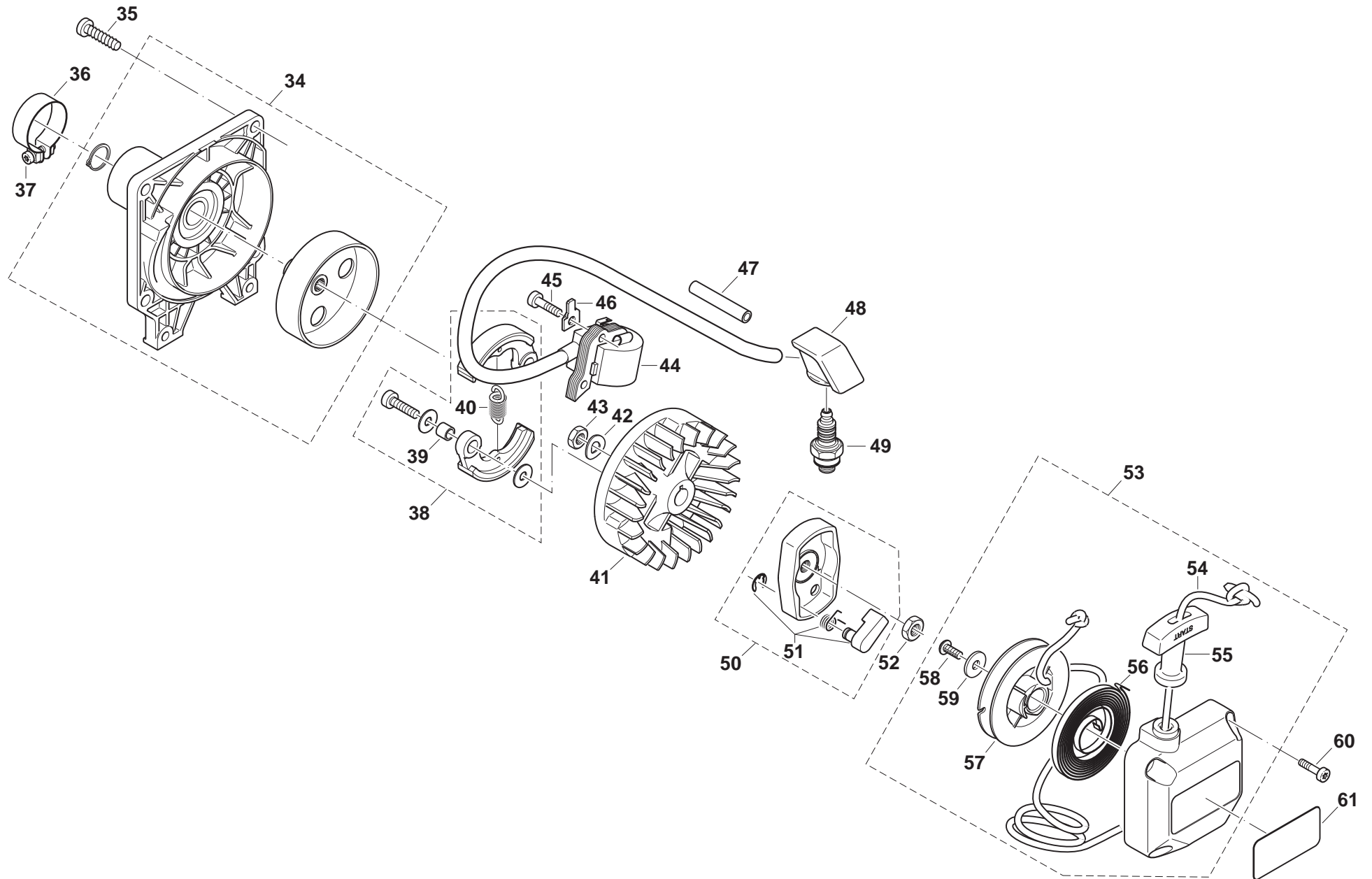

MS-341 U

2

Kupplung, Zündelektronik, Anwerfvorrichtung
Clutch, ignition electronics, starter
Embrayage, allumage électronique, dispos. de démarrage
Embrague, bobina encendido, dispos. de arranque

DOLMAR
A member of the **Takita** Group

Seite / Page	Pos.	MS-341 U	Teil-Nr. Part No. No. de pièce No. de pieza	Hinweise Notes Renseign. Nota	Bezeichnung	Spezifikation Specification	Description	Désignation	Denominación
2	34	1	387 217 000		KUPPLUNGSGEHÄUSE KPL. ROT		CLUTCH CASE ASSY. RED	CARTER D' EMBRAYAGE CPL. ROUGE	CÁRTER DE EMBRAGUE CPL. ROJO
2	35	4	913 467 254		INNENSTERN-SCHRAUBE		SCREW	VIS	TORNILLO
2	36	1	965 903 080		ROHRSCHELLE		CLAMPING RING	BRIDE DE SERRAGE	ABRAZADERA
2	37	1	908 006 255		ZYLINDERSCHRAUBE	M6x25	PAN HEAD ALLEN SCREW	VIS CYLINDRIQUE	TORNILLO CILINDRICO
2	38	1	010 181 000		SATZ FLIEHGEWICHTE	INC. 39,40	CLUTCH SHOE, SET	MASSELOTTE, JEU	PESO CENTRIFUGA, JUEGO
2	39	2	385 183 030		BUCHSE		BUSHING	DOUILLE	CASQUILLO
2	40	1	385 184 020		ZUGFEDER		SPRING	RESSORT	RESORTE
2	41	1	385 141 012		POLRAD		FLYWHEEL	ROUE POLAIRE	VOLANTE ENCENDIDO
2	42	1	926 208 001		FEDERSCHEIBE	B8	SPRING WASHER	RONDELLE ÉLASTIQUE	DISCO AMORTIGUADOR
2	43	1	920 308 024		6KT-MUTTER	M8x1	HEXAGONAL NUT	ECROU HEXAGONAL	TUERCA HEXAGONAL
2	44	1	385 143 031		ZÜNDANKER		IGNITION COIL	BOBINE D' ALLUM.	BOBINA ENCENDIDO
2	45	2	908 605 205		SCHRAUBE INNEN6RD	M5x20	H.L. SOCKET HEAD BOLT	VIS	TORNILLO
2	46	1	965 605 411		FLACHSTECKER		PLUG	FICHE	FICHA DE CONTACTO
2	47	m	970 502 110		ISOLIERSCHLAUCH	A6X0,5 100 mm	INSULATING HOSE	TUYAU ISOLANT	MANGO AISLANTE
2	48	1	385 147 100		KERZENSTECKER MIT FEDER		PLUG CAP WITH SPRING	FICHE DE BOUGIE A. RESSORT	TAPA BUJÍA CON MUELLE
2	49	1	965 603 021		ZÜNDKERZE		SPARK PLUG	BOUGIE	BUJÍA
2	50	1	387 166 050		STARTERRAD KPL.	INC. 51	STARTER WHEEL CPL.	ROUE DÉCLENCHÉUR CPL.	RUEDA DE ARRANQUE CPL.
2	51	1	957 166 387		KLINKENSATZ		STARTER RATCHET CPL.	CLIQUET CPL.	TRINQUETE ARRANQUE CPL.
2	52	1	920 308 024		6KT-MUTTER	M8x1	HEXAGONAL NUT	ECROU HEXAGONAL	TUERCA HEXAGONAL
2	53	1	387 160 301		ANWERFVORRICHTUNG SCHWARZ	INC. 54-59	STARTER BLACK	DISPOS. DE DÉMARRAGE NOIR	DISPOS. DE ARRANQUE NEGRO
2	54	1	387 164 010		ANWERFSEIL	ø 3 x 1150 mm	STARTER ROPE	CÂBLE DÉMARRAGE	CORDÓN DE ARRANQUE
2	54	1	985 000 150	ACC.	ANWERFSEIL	ø 3 x 100 m	STARTER ROPE	CÂBLE	CORDÓN DE ARRANQUE
2	55	1	957 404 691		ANWERFGRIF		STARTER GRIP	POIGNÉE DE LANCEMENT	TIRADOR DE ARRANQUE
2	56	1	387 163 010		RÜCKHOLFEDER		REWIND SPRING	RESSORT DE RAPPEL	RESORTE RETENCIÓN
2	57	1	387 162 020		SEILTROMMEL		CABLE DRUM	TAMBOUR DE CÂBLE	TAMBOR PARA CORDÓN
2	58	1	385 161 010		SCHRAUBE		SCREW	VIS	TORNILLO
2	59	1	387 161 030		SCHEIBE		DISC	DISQUE	DISCO
2	60	4	908 605 205		SCHRAUBE INNEN6RD	M5x20	H.L. SOCKET HEAD BOLT	VIS	TORNILLO
2	61	1	980 114 208		SCHILD	DOLMAR	LABEL	PLAQUE	CALCOMANIA

MS-341 U

3

Schalldämpfer, Luftfilter
Muffler, air filter
Pot d' échappement, filtre à air
Silencioso, filtro de aire

DOLMAR



A member of the *Trakita* Group

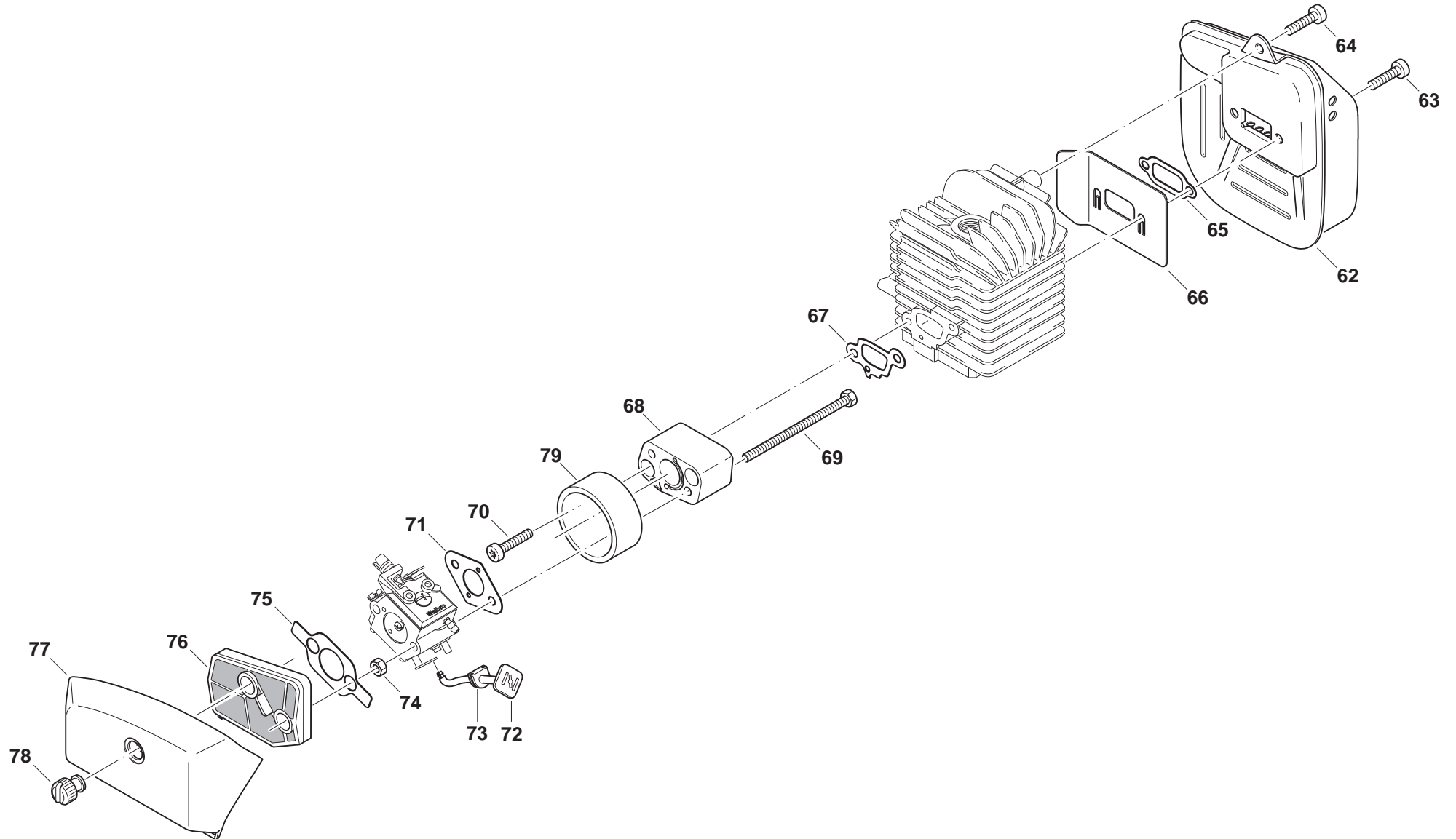

MS-341 U

3

Schalldämpfer, Luftfilter
Muffler, air filter
Pot d' échappement, filtre à air
Silencioso, filtro de aire

DOLMAR
A member of the **Takita** Group

Seite / Page	Pos.	MS-341 U	Teil-Nr. Part No. No. de pièce No. de pieza	Hinweise Notes Renseign. Nota	Bezeichnung	Spezifikation Specification	Description	Désignation	Denominación
3	62	1	385 174 101		SCHALLDÄMPFER KPL.		MUFFLER CPL.	POT D' ÉCHAPPEMENT CPL.	SILENCIADOR CPL.
3	63	2	908 405 205		SCHRAUBE INNEN6RD ZK	M5x20	H.L. SOCKET HEAD BOLT	VIS	TORNILLO
3	64	1	908 405 205		SCHRAUBE INNEN6RD ZK	M5x20	H.L. SOCKET HEAD BOLT	VIS	TORNILLO
3	65	1	965 527 040		DICHTUNG		GASKET	JOINT	JUNTA
3	66	1	385 174 012		KÜHLBLECH		COOLING PLATE	TÔLE DE REFRROIDISSEMENT	CHAPA DE REFRIGERATION
3	67	1	965 527 030		ZWISCHENFLANSCHDICHTUNG		GASKET	JOINT	JUNTA
3	68	1	385 131 050		ZWISCHENFLANSCH		INTERMEDIATE FLANGE	BRIDE INTERMÉDIAIRE	BRIDA INTERMEDIA
3	69	2	900 105 704		6KT-SCHRAUBE		SCREW	VIS	TORNILLO
3	70	2	908 005 255		ZYLINDERSCHRAUBE	M5x25	PAN HEAD ALLEN SCREW	VIS CYLINDRIQUE	TORNILLO CILINDRICO
3	71	1	965 527 020		EINLAßFLANSCHDICHTUNG		GASKET	JOINT	JUNTA
3	72	1	031 150 730		CHOKESTANGE	(HS 239)	CHOKE SHAFT	LEVIER POUR CLAPET D' AIR	PALANCE DE VÁLVULA DE AIRE
3	73	1	965 401 016		GUMMITÜLLE		RUBBER BUSH	GAINÉ CAOUTCHOUC	BOQUILLA DE CAUCHO
3	74	2	920 205 000		SECHSKANTMUTTER	M 5	HEXAGON NUT	ECROU À SIX PANS	TUERCA HEXAGONAL
3	75	1	965 527 060		FILTERDICHTUNG		GASKET	JOINT	JUNTA
3	76	1	385 173 100		LUFTFILTER		AIR FILTER	FILTRE À AIR	FILTRO DE AIRE
3	77	1	387 118 321		FILTERDECKEL ROT		COVER RED	COUVERCLE ROUGE	TAPA ROJO
3	78	1	001 118 062		MUTTER	M5	NUT	ECROU	TUERCA
3	79	1	965 404 630		DICHTUNG FÜR ZWISCHENFLANSCH	NEOPRENE	GASKET	JOINT	JUNTA

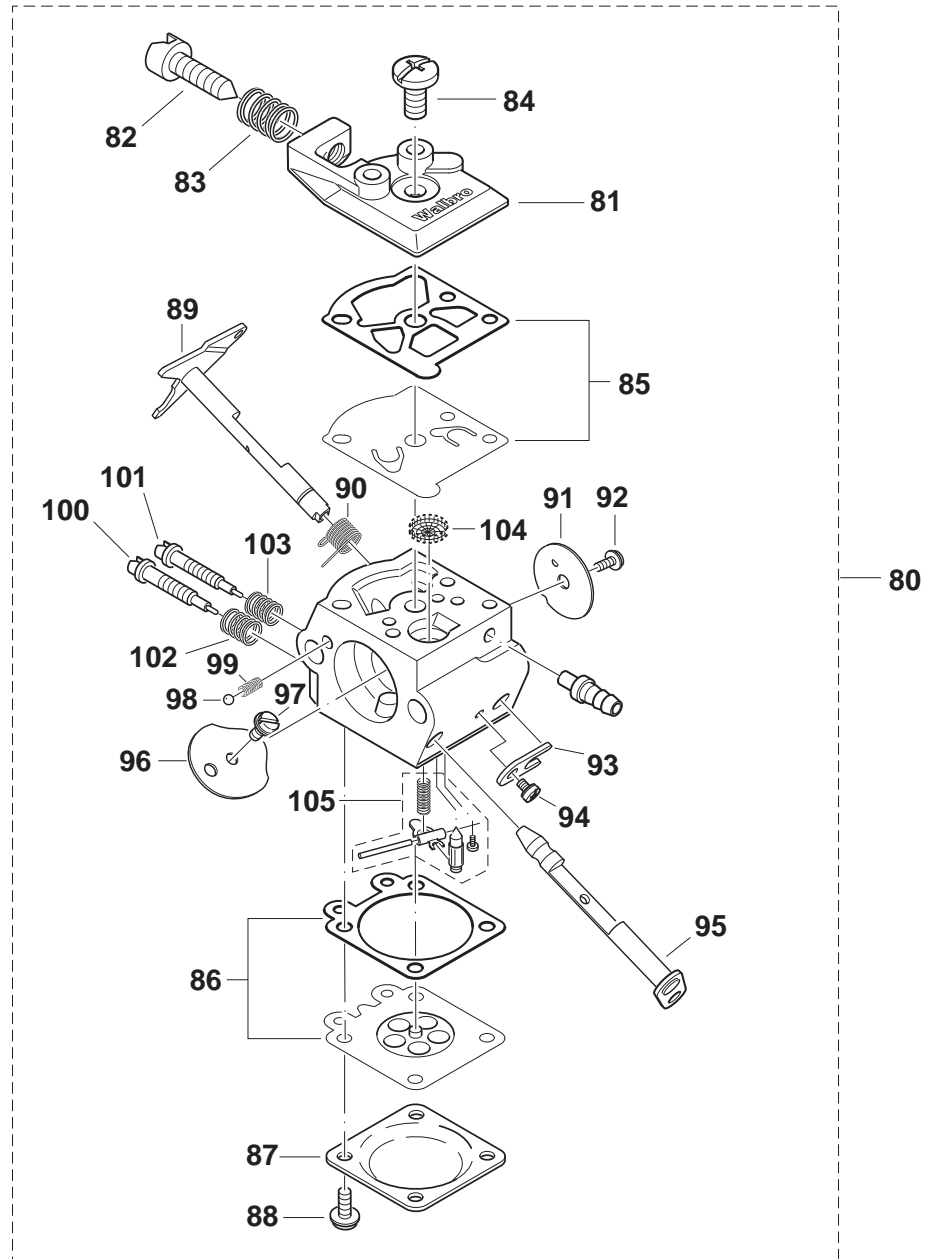

MS-341 U

4

Vergaser
Carburetor
Carburateur
Carburador**DOLMAR**A member of the **Takita** Group

Seite / Page	Pos.	MS-341 U	Teil-Nr. Part No. No. de pièce No. de pieza	Hinweise Notes Renseign. Nota	Bezeichnung	Spezifikation Specification	Description	Désignation	Denominación
4	80	1	957 151 170		VERGASER	INC. 81-105	CARBURETOR	CARBURATEUR	CARBURADOR
4	81	1	021 151 160		PUMPENDECKEL KPL.		PUMP COVER	COUVERCLE DE POMPE	TAPA DE BOMBA
4	82	1	001 151 400		LEERLAUF-ANSCHLAGSCHR.		IDLE STOP SCREW	VIS DE BUTÉE DE RALENTI	TORNILLO DE TOPERALENTI
4	83	1	021 151 230		DRUCKFEDER	S	COMPRESSION SPRING	RESSORT DE PRESSION	RESORTE DE PRESIÓN
4	84	1	118 151 190		SCHRAUBE		SCREW	VIS	TORNILLO
4	85	1	957 151 010		SATZ PUMPENMEMBRAN		PUMP DIAPHRAGM, SET	MEMBRANE DE POMPE, JEU	MEMBRANA DE LA BOMBA
4	86	1	957 151 020		SATZ STEUERMEMBRAN		CONTROL DIAPHRAGM, SET	MEMBRANE DE COMM., JEU	MEMBRANA DE MANDO, JU.
4	87	1	021 151 120		MEMBRANDECKEL		DIAPHRAGM COVER	COUVERCLE DE MEMBRANE	TAPA DE MEMBRANA
4	88	4	378 151 220		SCHRAUBE		SCREW	VIS	TORNILLO
4	89	1	385 151 040		DROSSELKLAPPENWELLE		THROTTLE SHAFT	AXE CLAPET D' ÉTRANGLEMENT	EJE VÁLVULA REG.
4	90	1	371 151 310		DREHFEDER		SPRING	RESSORT	MUELLE
4	91	1	001 151 680		DROSSELKLAPPE		THROTTLE SHUTTER	CLAPET D' ÉTRANGLEMENT	VÁLVULA REG.
4	92	1	118 151 060		SCHRAUBE		SCREW	VIS	TORNILLO
4	93	1	108 151 350		WELLENSICHERUNG		SHAFT CLIP	TÔLE DE SÉCURITÉ	PIEZA SEGURIDAD ARBÓL
4	94	1	378 151 220		SCHRAUBE		SCREW	VIS	TORNILLO
4	95	1	387 151 100		CHOKEWELLE MIT HEBEL		SHAFT ASSY. - CHOKE	AXE CLAPET D' AIRE	EJE VÁLVULA AIRE
4	96	1	001 151 350		CHOKEKLAPPE		CHOKE SHUTTER	CLAPET D' AIR	VÁLVULA AIRE
4	97	1	118 151 060		SCHRAUBE		SCREW	VIS	TORNILLO
4	98	1	118 151 170		ARRETIERKUGEL		LOCKING BALL	BILLE D' ARRÊT	BOLA DE TOPE
4	99	1	118 151 160		ARRETIERFEDER		LOCKING SPRING	RESSORT D' ARRÊT	RESORTE DE TOPE
4	100	1	001 151 420		VOLLGAS-STELLSCHRAUBE		MAIN ADJUSTM. SCREW	VIS DE RÉGL. DE PLEIN GAZ	TORNILLO REG.
4	101	1	001 151 410		LEERLAUF-STELLSCHRAUBE		IDLING ADJUSTM. SCREW	VIS DE RÉGL. DE RALENTI	TORNILLO DE TOPE RAL.
4	102	1	021 151 530		FEDER	H	SPRING	RESSORT	RESORTE
4	103	1	021 151 480		FEDER	L	SPRING	RESSORT	RESORTE
4	104	1	021 151 180		SIEB		SCREEN	TAMIS	TAMIZ
4	105	1	957 150 040		SATZ STEUERTEILE		SET OF CONTROL PARTS	JEU DE PIÈCES DE COMM.	JUEGO PIEZAS DE MANDO

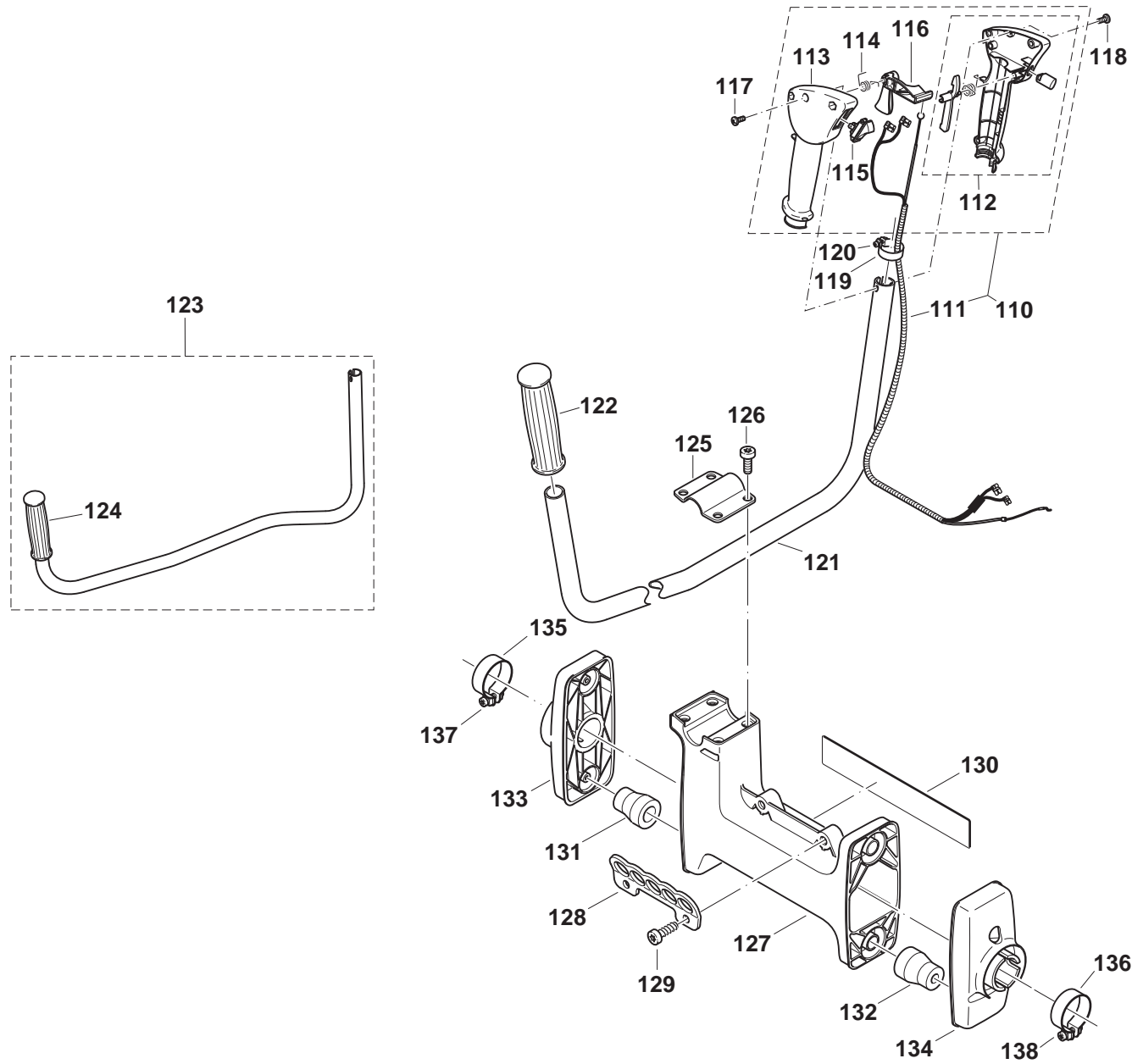

MS-341 U

5

Handgriff, Bowdenzug
Handle, Bowden cable
Poignée, câble de commande
Mango, transmis. flexible Bowden

DOLMAR
A member of the **Takita** Group

Seite / Page	Pos.	MS-341 U	Teil-Nr. Part No. No. de pièce No. de pieza	Hinweise Notes Renseign. Nota	Bezeichnung	Spezifikation Specification	Description	Désignation	Denominación
5	110	1	369 313 206		GASGRIFF KPL.	INC. 111-116	OPERATING LEVER	LEVIER DE REGLAGE CPL.	BOTÓN DE MANDO CPL.
5	111	1	385 726 072		GASZUG KPL.		BOWDEN CABLE CPL.	DISPOSITIF DE TIRAGE, CPL.	TRACCIÓN BOWDEN, CPL.
5	112	1	369 313 291		GRIFFHÄLFTE RECHTS KPL.		HANDLE HALF, RIGHT, CPL.	DEMI-POIGNÉE, DROITE	SEMI-MANGO, DERECHA
5	113	1	369 313 011		GRIFFHÄLFTE LINKS	ø 22	HANDLE HALF, LEFT	DEMI-POIGNÉE, GAUCHE	SEMI-MANGO, IZQUIERDA
5	114	1	369 311 071		SCHENKELFEDER FÜR GASHEBEL		SPRING	RESSORT	MUELLE
5	115	1	975 001 241		KURZSCHLUßSCHALTER		SHORT-CIRCUIT SWITCH	INTERRUPTEUR COURT-CIRCUIT	INTERRUPTOR CORTO CIRCUITE
5	116	1	369 311 081		GASHEBEL		THROTTLE LEVER	LEVIER D ACCELERRATION	ACELERADOR
5	117	1	915 735 100		SCHRAUBE	3,5x10	SCREW	VIS	TORNILLO
5	118	1	915 735 100		SCHRAUBE	3,5x10	SCREW	VIS	TORNILLO
5	119	1	965 903 080		ROHRSCHELLE		CLAMPING RING	BRIDE DE SERRAGE	ABRAZADERA
5	120	1	908 006 255		ZYLINDERSCHRAUBE	M6x25	PAN HEAD ALLEN SCREW	VIS CYLINDRIQUE	TORNILLO CILINDRICO
5	121	1	385 310 161		GRIFFROHR		HANDLE	POIGNÉE	MANGO
5	122	1	387 311 100		HANDGRIFF, LINKS		HANDLE, LEFT	POIGNÉE, GAUCHE	MANGO, IZQU.
5	123	1	385 310 401	ACC.	MÄHLENKER	INC. 124	MOWING HANDLE	MANCHE	MANGO DESBROZADORA
5	124	1	387 311 100		HANDGRIFF, LINKS		HANDLE, LEFT	POIGNÉE, GAUCHE	MANGO, IZQU.
5	125	1	387 310 031		ROHRSCHELLE II		CLAMPING HOLDER	DISPOSITIF DE SERRAGE	SOPORTE PRESOR
5	126	4	908 006 145		SCHRAUBE	M6x14	SCREW	VIS	TORNILLO
5	127	1	387 310 321		GRIFFANBINDUNG ROT		HANDLE HOLDER RED	BRIDE DE POIGNÉE ROUGE	FIJACION DE MANGO ROJO
5	128	1	385 316 011		LOCHLEISTE		ORIFICE PLATE	BANDE A TROUS	CHAPA AGUJERADA
5	129	2	913 467 164		INNENSTERN-SCHRAUBE		SCREW	VIS	TORNILLO
5	130	1	980 116 023		SCHILD	MS-341 U	LABEL	PLAQUE	CALCOMANIA
5	131	2	965 403 380		RINGPUFFER		RING BUFFER	AMORTISSEUR EN ANNEAU	TOPE ANULAR
5	132	2	965 403 380		RINGPUFFER		RING BUFFER	AMORTISSEUR EN ANNEAU	TOPE ANULAR
5	133	1	387 310 011		KLEMMSTÜCK ROT		CLAMPING PIECE RED	PIÈCE INTERCALAIRE ROUGE	RETEN ROJO
5	134	1	387 310 011		KLEMMSTÜCK ROT		CLAMPING PIECE RED	PIÈCE INTERCALAIRE ROUGE	RETEN ROJO
5	135	1	965 903 080		ROHRSCHELLE		CLAMPING RING	BRIDE DE SERRAGE	ABRAZADERA
5	136	1	965 903 080		ROHRSCHELLE		CLAMPING RING	BRIDE DE SERRAGE	ABRAZADERA
5	137	1	908 006 255		ZYLINDERSCHRAUBE	M6x25	PAN HEAD ALLEN SCREW	VIS CYLINDRIQUE	TORNILLO CILINDRICO
5	138	1	908 006 255		ZYLINDERSCHRAUBE	M6x25	PAN HEAD ALLEN SCREW	VIS CYLINDRIQUE	TORNILLO CILINDRICO

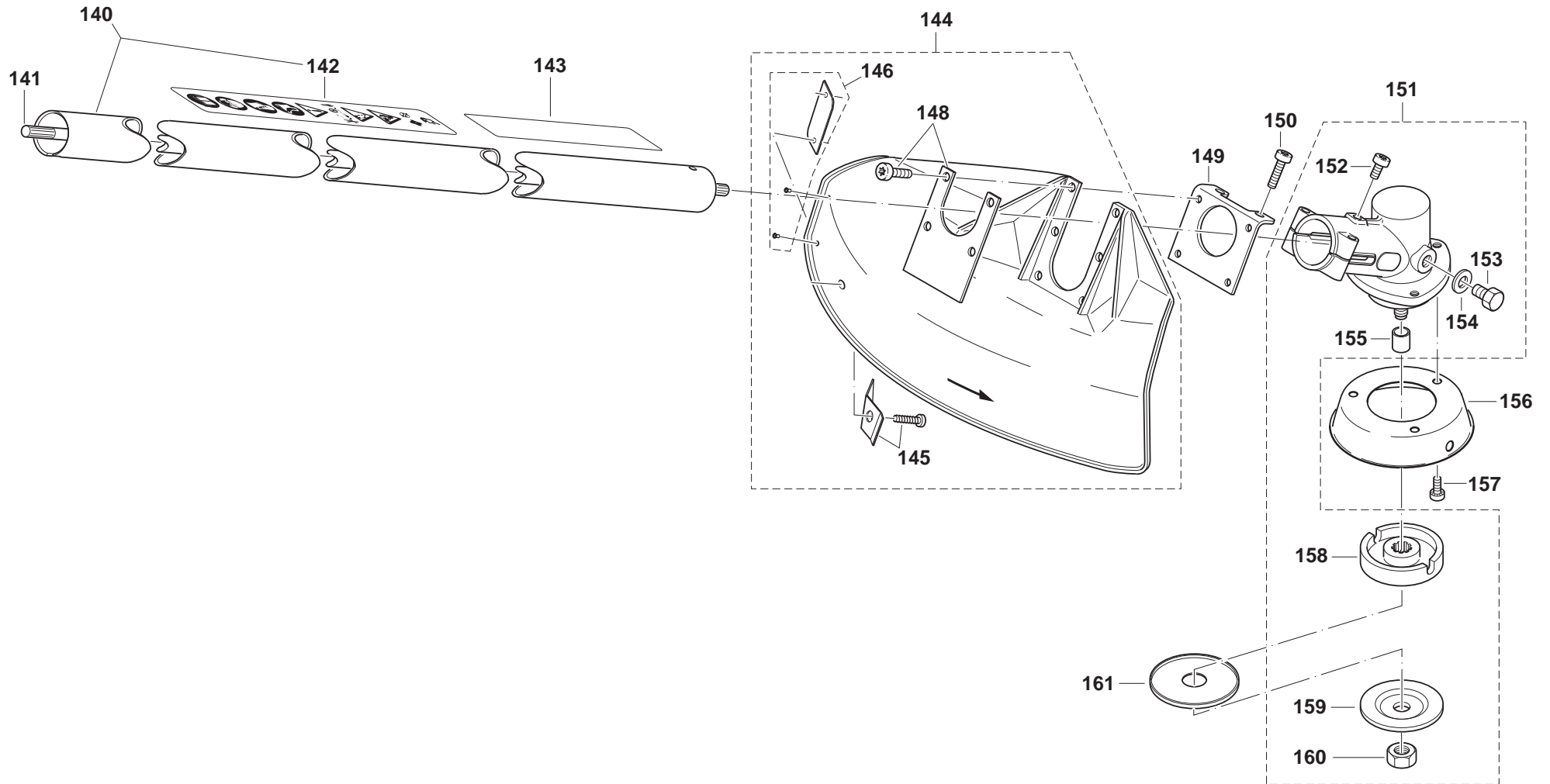

MS-341 U

6

Hauptrohr, Getriebe, Schutzhaube
Main pipe, gear, protection hood
Tube principal, engrenage, capot de protection
Tubo principal, engranaje, cubierta protectora

DOLMAR
A member of the **Takita** Group

Seite / Page	Pos.	MS-341 U	Teil-Nr. Part No. No. de pièce No. de pieza	Hinweise Notes Renseign. Nota	Bezeichnung	Spezifikation Specification	Description	Désignation	Denominación
6	140	1	010 261 030		HAUPTROHR KPL.	INC. 142	MAIN PIPE ASSY.	TUBE PRINCIPAL CPL.	TUBO PRINCIPAL CPL.
6	141	1	387 228 030		HAUPTWELLE		TRANSMISSION SHAFT	ARBRE DE TRANSMISSION	ARBOL DE TRANSMISIÓN
6	142	1	980 114 628		SICHERHEITSAUFKLEBER		CAUTION LABEL	PLAQUE	CALCOMANIA
6	143	1	980 114 073		SCHILD	DOLMAR	LABEL	PLAQUE	CALCOMANIA
6	144	1	010 341 202		SCHUTZHAUBE KPL.	INC. 145,146,148	PROTECTION HOOD ASSY.	CAPOT DE PROTECTION CPL.	CUBIERTA PROTECTORA CPL.
6	145	1	957 341 010		FADENMESSER		LINE CUTTER	COUPEAU DE FIL	CUCHILLA DE HILOS
6	146	1	957 341 020		SCHUTZHAUBENVERSTÄRKUNG KPL.		PROT. COV. REINFORCEM. CPL.	RENFORT DE CAPOT DE PROT. CPL.	REFUERZO CUBIERTA CPL.
6	148	1	385 341 070		UNTERLEGPLATTE KPL.		PLATE CPL.	PLAQUE CPL.	PLANCHA CPL.
6	149	1	387 341 031		FLANSCHBLECH		FLANGE PLATE	ÈQUERRE DE FIXATION	CHAPA DE BRIDA
6	150	2	908 005 255		ZYLINDERSCHRAUBE	M5x25	PAN HEAD ALLEN SCREW	VIS CYLINDRIQUE	TORNILLO CILINDRICO
6	151	1	387 200 202		GETRIEBE KPL.	INC. 152-155,158-160	GEAR CPL.	ENGRENAGE CPL.	ENGRANAJE CPL.
6	152	1	908 005 095		SCHRAUBE	M5x9	SCREW	VIS	TORNILLO
6	153	1	900 208 104		6KT-SCHRAUBE		SCREW	VIS	TORNILLO
6	154	1	963 604 306		DICHTUNG		GASKET	JOINT	JUNTA
6	155	1	387 228 020		DISTANZRING		DISTANCE RING	BAGUE DE DISTANCE	ANILLO SEPARADOR
6	156	1	387 224 050		WICKELSCHUTZ		WINDING PREVENTER	CAPOT DE PROTECTION	TAPA PROTECTORA
6	157	3	908 005 095		SCHRAUBE	M5x9	SCREW	VIS	TORNILLO
6	158	1	387 224 011		AUFNAHMESCHEIBE		MOUNTING DISC	DISQUE DE SUPPORT	DISCO DE SUJECIÓN
6	159	1	387 224 021		DRUCKSCHEIBE		PRESSURE DISC	DISQUE DE PRESSION	DISCO DE PRESIÓN
6	160	1	387 228 040		MUTTER M10X1,25 L NYLON		SAFETY NUT	ECCOU DE SECURITE	TUERCA SEGURIDAD
6	161	1	385 224 521		STÜTZSCHEIBE	TYP 385	COVERING WASHER	DISQUE DE RECOUVREMENT	ARANDELA DE PROTECCION

MS-341 U

7

Schneidwerkzeuge, Werkzeug
Cutting tools, tools
Outils tranchants, outils
Herramientas de corte, herramientas

DOLMAR



A member of the *Trakita* Group

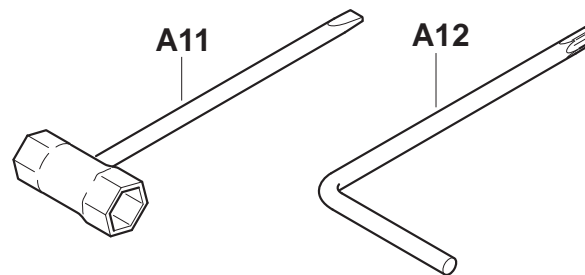
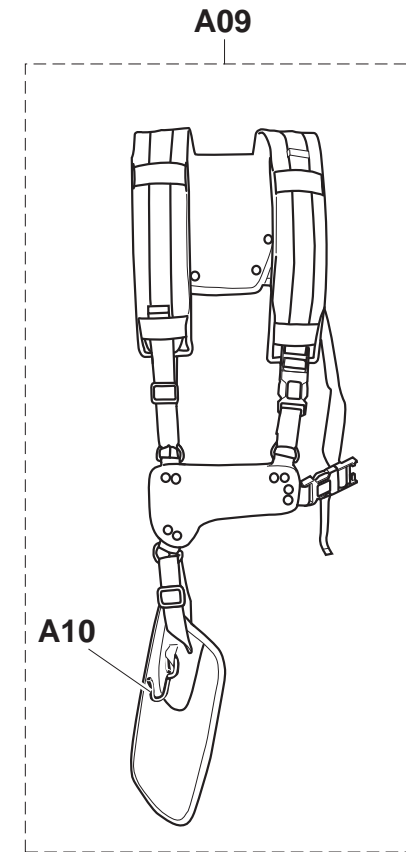
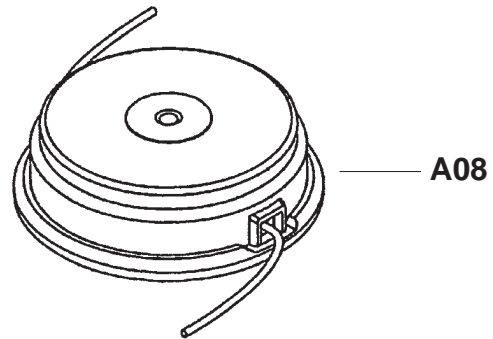
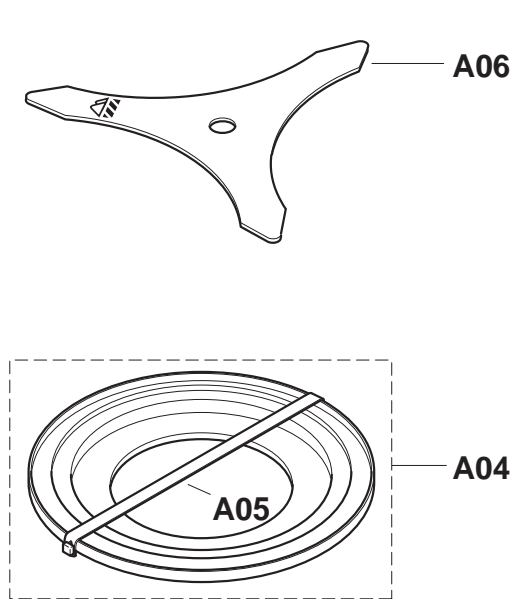

MS-341 U

7

Schneidwerkzeuge, Werkzeug
Cutting tools, tools
Outils tranchants, outils
Herramientas de corte, herramientas

DOLMARA member of the **Takita** Group

Seite / Page	Pos.	MS-341 U	Teil-Nr. Part No. No. de pièce No. de pieza	Hinweise Notes Renseign. Nota	Bezeichnung	Spezifikation Specification	Description	Désignation	Denominación
7	A04	1	370 341 450		TRANSPORTSCHUTZ	INC. A05	PROTECTION CASE	ENVELOPPE	ENVOLTURA PROTECTORA
7	A05	1	370 341 410		BEFESTIGUNGSGUMMI		CLAMPING RUBBER	FIXATION	FIJACIÓN
7	A06	1	385 224 350		3-ZAHN-DICKICHTMESSER	ø 255x20	STEEL BUSH CUTTER	LAME DE TAILLIS	CUCHILLA DE 3 DIENTES
7	A08	1	384 224 503		2-FADENKOPF	Automatik (ø3,0mm), M10x1,25 LH / M12x1,5 LH	DUAL LINE TRIMMING HEAD	TÊTE À 2 FILS DE NYLON	CABEZAL DE 2 HILOS DE NILÓN
7	A09	1	988 048 324		SCHULTERGURT	DOUBLEXX DOLMAR INC. A10	BAND ASS'Y	BRETELLE	HARNESS
7	A10	1	385 260 040		KARABINERHAKEN		SNAPHOOK	PORTE-MOUSQUETON	PORTA-CARABINA
7	A11	1	941 717 191		KOMBISCHLÜSSEL	SW 17/19	UNIVERSAL WRENCH	CLÉ COMBINÉE	LLAVE DE BUJIA
7	A12	1	940 827 000		WINKELSCHRAUBENDREHER	T27	ANGLED SCREW DRIVER	CLÉ ANGLE	LLAVE ANGULAR

MS-341 U

DOLMARA member of the **Takita** Group

	Zeichenerklärung	Key to symbols	Légende	Explicación de símbolos
=> 1999999 2000000 => 2003.04 => TI 2003/07 Acc. = { m Corr.	Produktion bis Serien-Nr. Neues Teil ab Serien-Nr. Neues Teil ab Jahr / Monat Siehe Technische Information Jahr / Nr. Zubehör (nicht im Lieferumfang) Keine Serienausführung, jedoch verwendbar Beinhaltet Positions-Nr. Meterware Druckfehlerberichtigung	Production to serial number New part from serial number New part from Year / Month See Technical Information Year / No. Accessories (not included in the delivery inventory) No standard execution, may be used Contains item number Sold by the meter Error correction	Production jusqu'à n° de série Nouveau pièce à partir du n° de série Nouveau pièce à partir de année / mois Voir information technique année / n° Accessoires (non compris dans la livraison) Aucune exécut. en série, cependant utilisable contient n° de numéro Au mètre Rectification d'erreurs	Producción hasta N° de serie Pieza nueva a partir de N° de serie Pieza nueva a partir de año / mes Véase inform. técnico año / N° Accesorios (no incluido en la extensión del suministro) No es de serie, pero sirve Contiene pos N° Por metro Fe de erratas
	Änderungen vorbehalten	Specifications subject to change without notice	Changements sans préavis	Mejoras constructivas sin previo aviso