

Spare Parts List
Ersatzteilliste
Liste de pièces détachées
Lista de piezas de repuesto

2014-10

HP-1500

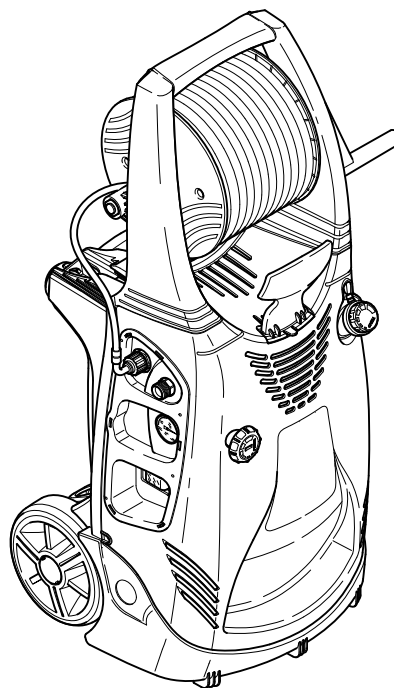

DOLMAR



A member of the *Makita* Group

995700198 (D, GB, F, E)

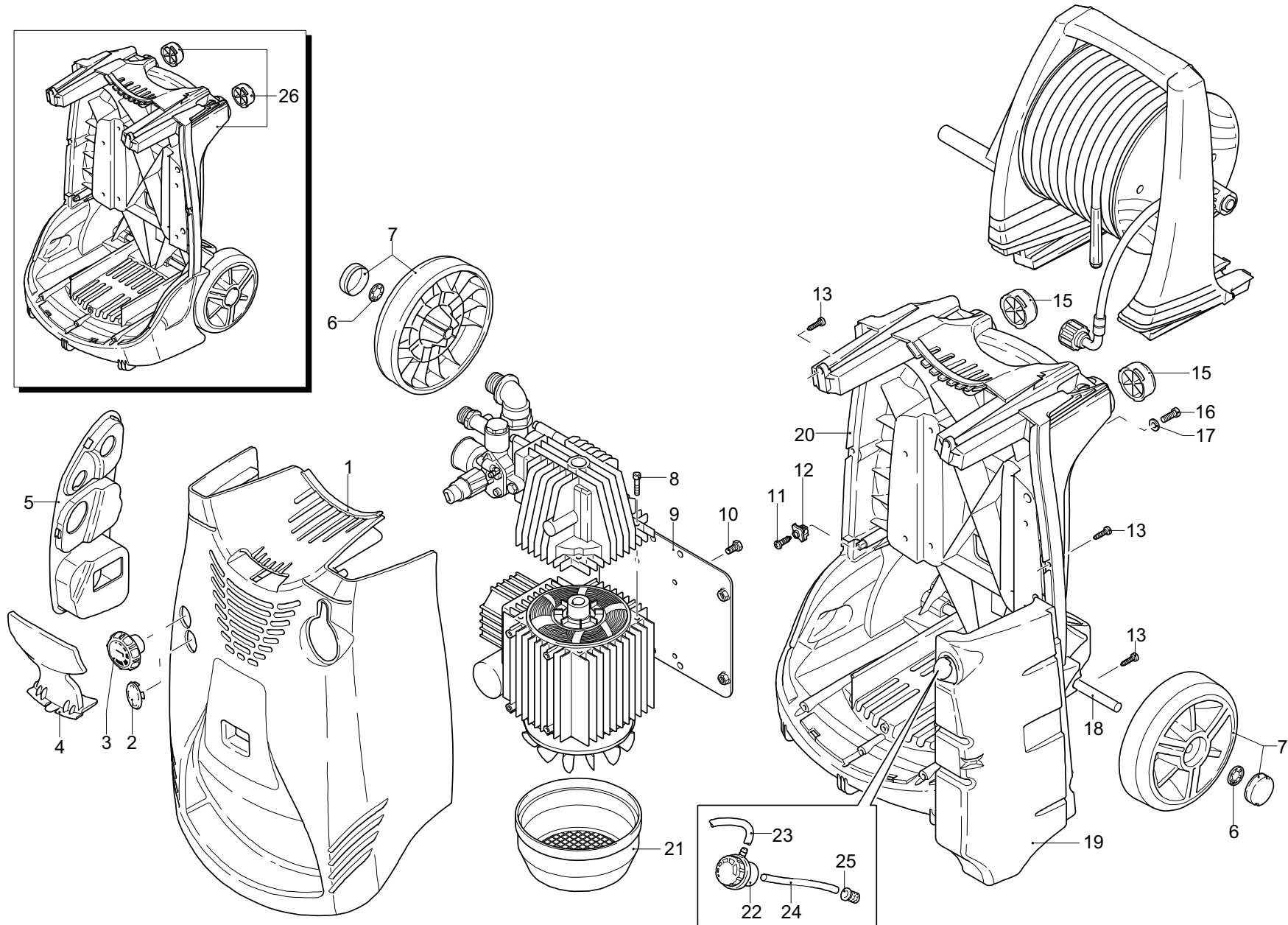
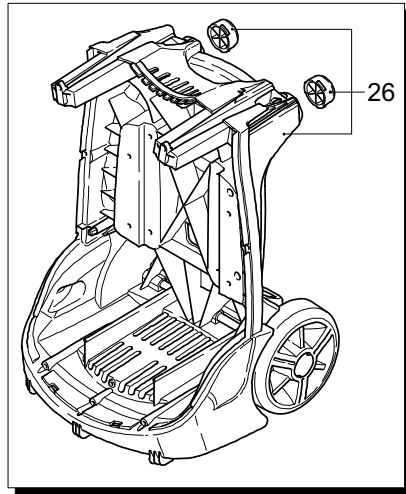

HP-1500

1

Gehäuse
Case
Carter
Carter**DOLMAR**A member of the **Takita** Group

Seite / Page	Pos.	Teil-Nr. Part No. No. de pièce No. de pieza	Hinweise Notes Renseign. Nota	Bezeichnung	Spezifikation Specification	Description	Désignation	Denominación
1	1	1 609 500 047		GEHÄUSE VORN, ROT	red	CASING	CARTER	CÁRTER
1	2	1 609 500 340		ABDECKSTOPFEN		PLUG	BOUCHON	TAPON
1	3	1 609 500 310		KNOPF		KNOB	BOUTON	BOTÓN
1	4	1 609 500 050		HAKEN		HOOK	TENON	GANCHO
1	5	1 609 500 260		DECKEL		COVER	COUVERCLE	TAPA
1	6	2 609 680 880		UNTERLEGSSCHEIBE		WASHER	RONDELLE	ARANDELA
1	7	2 609 500 320		ABTRIEBSRAD	ø 175	DRIVEN GEAR	ROUE DENTÉE	PIÑON
1	8	4 609 260 780		SCHRAUBE	TCEI M5x25	SCREW	VIS	TORNILLO
1	9	1 609 500 100		BEFESTIGUNGSBLECH		FIXING PLATE	TÔLE DE FIXATION	CHAPA DE FIJACIÓN
1	10	4 609 320 350		SCHRAUBE	TE M6x12	SCREW	VIS	TORNILLO
1	11	1 609 100 300		SCHRAUBE	5x16	SCREW	VIS	TORNILLO
1	12	1 609 600 100		KABELVERSCHRAUBUNG		CABLE GLAND	SERRE-CÂBLE	PRENSACABLE
1	13	7 609 100 300		SCHRAUBE	5x16	SCREW	VIS	TORNILLO
1	15	2 609 500 130		GUMMIFUß		RUBBER FOOT	PIED EN CAOUTCHOUC	PIE DE GOMA
1	16	4 609 880 280		SCHRAUBE	TCEI M6x18	SCREW	VIS	TORNILLO
1	17	4 609 180 300		SCHEIBE	øi 6,2	WASHER	RONDELLE	ARANDELA
1	18	1 609 500 120		RADACHSE		WHEEL AXLE	ESSIEU	EJE DE LAS RUEDAS
1	19	1 609 509 001		TANK FÜR REINIGUNGSMITTEL		DETERGENT TANK ASSEMBLY	RÉSERVOIR	DEPOSITO
1	20	1 609 500 010		GEHÄUSE		BODY	FOND	FONDO
1	21	1 609 342 040		LÜFTERDECKEL		FAN COWLING	CACHE VENTILATEUR	CUBRE-VENTILADOR
1	22	1 609 042 113		TANKVERSCHLUß		TANK PLUG	BOUCHON RÉSERVOIR	CIERRE DEPÓSITO
1	23	1 609 500 330		SCHLAUCH		DETERGENT HOSE	TUBE	TUBO
1	24	1 609 500 330		SCHLAUCH		DETERGENT HOSE	TUBE	TUBO
1	25	1 609 000 230		FILTER		FILTER	FILTRE	FILTRO
1	26	1 609 509 000		GEHÄUSE VORMONTAGE		BODY ASSEMBLY	FOND D'ASSEMBLAGE	FONDO DE MONTAJE

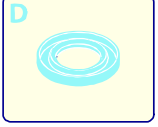
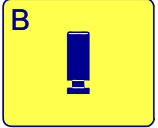
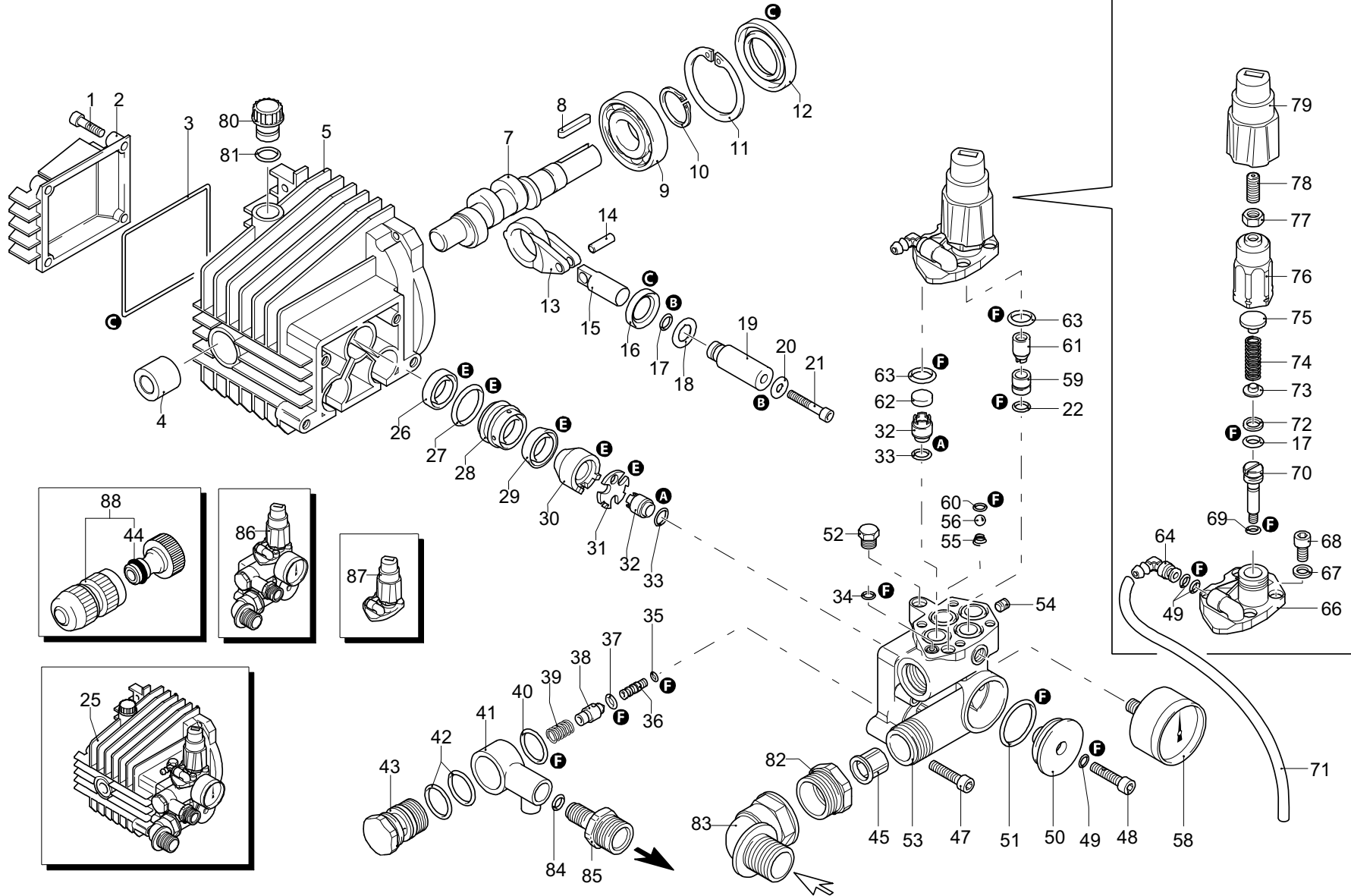

HP-1500

2

Pumpe
Pump
Pompe
Bomba



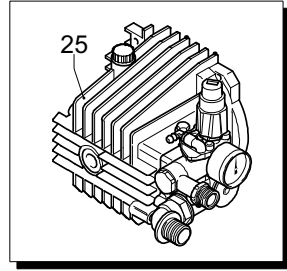
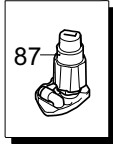
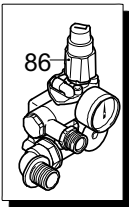
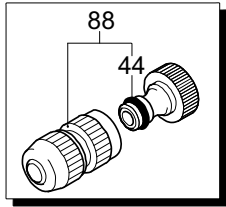
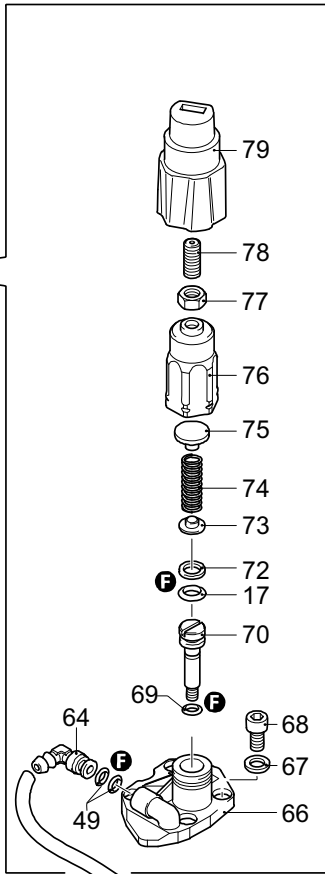
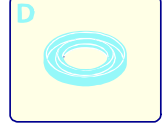
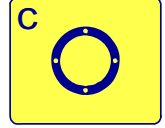
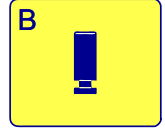
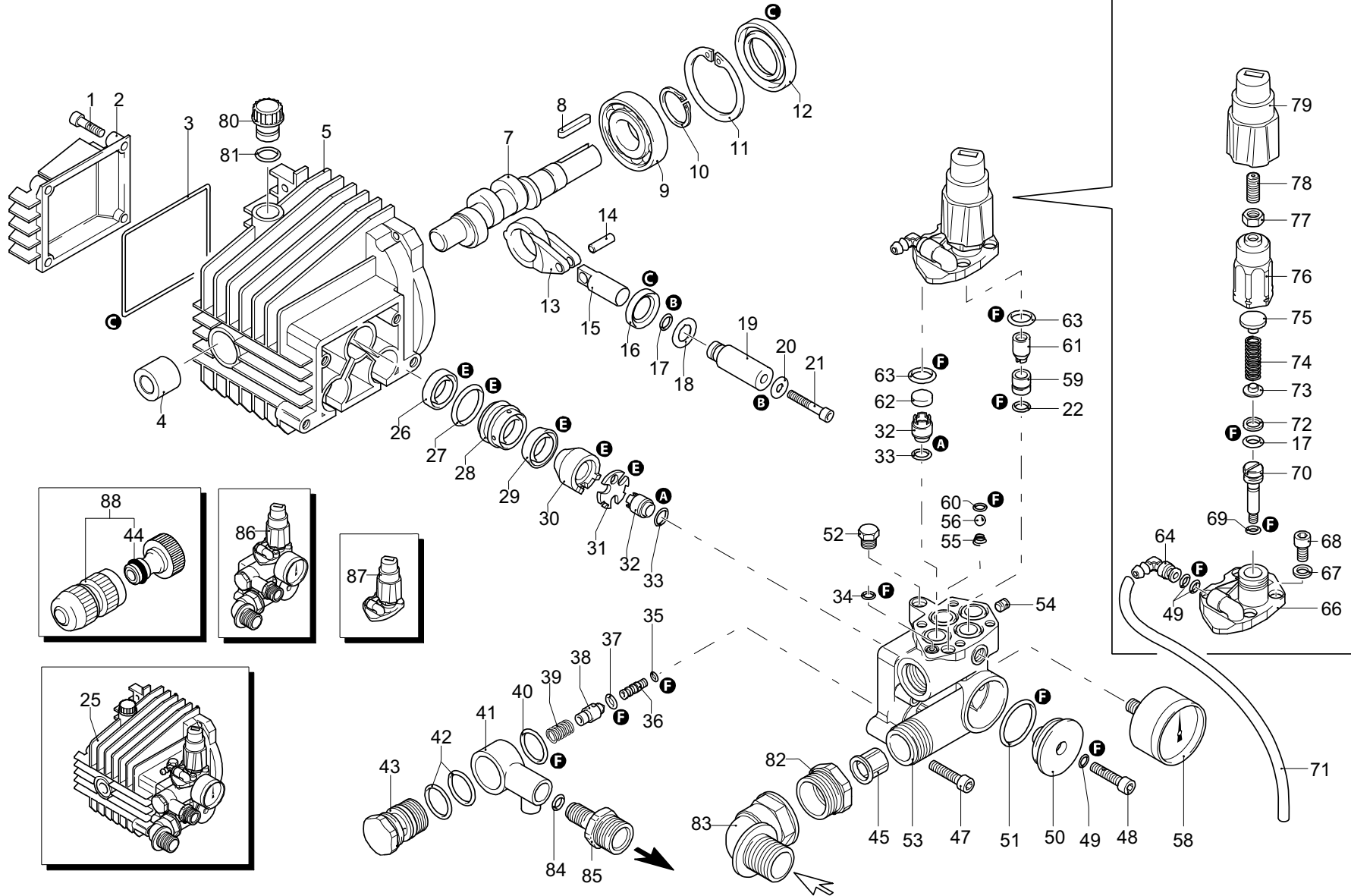

 A member of the **Takita** Group

Seite / Page	Pos.	Teil-Nr. Part No. No. de pièce No. de pieza	Hinweise Notes Renseign. Nota	Bezeichnung	Spezifikation Specification	Description	Désignation	Denominación
2	1	4 609 260 780		SCHRAUBE	TCEI M5x25	SCREW	VIS	TORNILLO
2	2	1 609 344 060		DECKEL		COVER	COUVERCLE	TAPA
2	3	1 609 040 710		O-RING	ø 56x2	O-RING	JOINT TORIQUE	GUARNICIÓN OR
2	4	1 609 260 050		BUCHSE		BUSHING	DOUILLE	CASQUILLO
2	5	1 609 344 050		PUMPENKÖRPER		PUMP BODY	CORPS POMPE	CUERPO BOMBA
2	7	1 609 340 170		WELLE		SHAFT	ARBRE	EJE
2	8	1 609 880 111		SPLINT		KEY	LANGUETTE	LENGÜETA
2	9	1 609 341 070		LAGER		BEARING	PALIER	COJINETE
2	10	1 609 480 890		SICHERUNGSRING	øe 17	RETAINING RING	CIRCLIP	ANILLO SEGURIDAD
2	11	1 609 111 120		SICHERUNGSRING	øi 47	RETAINING RING	CIRCLIP	ANILLO SEGURIDAD
2	12	1 609 341 080		ÖLDICHTUNG		OIL SEAL	ÉTANCHÉITÉ HUILE	RETENCIÓN ACEITE
2	13	3 609 340 060		PLEUELSTANGE		CONNECTING-ROD	BIELLE	BIELA
2	14	3 609 340 080		STECKER		PIN	FICHE	CLAVIJA
2	15	3 609 340 070		STANGE		PIN	TIGE	VARILLA
2	16	3 609 260 460		ÖLDICHTUNG		OIL SEAL	ÉTANCHÉITÉ HUILE	RETENCIÓN ACEITE
2	17	4 609 600 180		O-RING	ø 7,66x1,78	O-RING	JOINT TORIQUE	GUARNICIÓN OR
2	18	3 609 341 010		SCHEIBE		PLATE	DISQUE	DISCO
2	19	3 609 342 740		KOLBEN	ø 15	PISTON	PISTON	PISTÓN
2	20	3 609 341 020		UNTERLEGSSCHEIBE	6x10x1	WASHER	RONDELLE	ARANDELA
2	21	3 609 850 670		SCHRAUBE	TCEI M6x35	SCREW	VIS	TORNILLO
2	22	1 609 600 180		O-RING	ø 7,66x1,78	O-RING	JOINT TORIQUE	GUARNICIÓN OR
2	25	1 609 349 265		PUMPE KPL.		PUMP ASSEMBLY	POMPE CPL.	BOMBA CPL.
2	26	3 609 260 440		WASSERDICHTUNG	C1	WATER SEAL	ÉTANCHÉITÉ EAU	RETENCIÓN AGUA
2	27	3 609 770 260		O-RING	ø 23,52x1,78	O-RING	JOINT TORIQUE	GUARNICIÓN OR
2	28	3 609 342 730		KOLBENFÜHRUNG	ø 15	PISTON GUIDE	GUIDAGE DE PISTON	GUÍA
2	29	3 609 342 760		DICHTUNG		GASKET	JOINT	JUNTA
2	30	3 609 342 720		TRAGRING		SUPPORT RING	SUPPORT	SOPORTE
2	31	3 609 342 750		PLATTE		PLATE	PLAQUE	PLANCHA
2	32	6 609 349 053		VENTIL KPL.		VALVE, CPL.	SOUPAPE CPL	VÁLVULA CPL.
2	33	6 609 800 560		O-RING	ø 8,73x1,78	O-RING	JOINT TORIQUE	GUARNICIÓN OR
2	34	1 609 390 341		O-RING	ø 5x2	O-RING	JOINT TORIQUE	ANILLO DE GUARNICIÓN
2	35	1 609 343 110		O-RING	ø 4x1,1	O-RING	JOINT TORIQUE	ANILLO DE GUARNICIÓN
2	36	1 609 342 710		DÜSE		NOZZLE	TUYÈRE	TOBERA
2	37	1 609 460 430		O-RING	ø 4x2,5	O-RING	JOINT TORIQUE	GUARNICIÓN OR
2	38	1 609 460 260		KOLBEN		PISTON	PISTON	PISTÓN
2	39	1 609 540 140		FEDER		SPRING	RESSORT	RESORTE
2	40	1 609 880 270		O-RING	ø 17,17x1,78	O-RING	JOINT TORIQUE	ANILLO DE GUARNICIÓN
2	41	1 609 560 090		ANSCHLUSSSTUTZEN		FITTING	RACCORD	RACOR
2	42	2 609 770 570		O-RING	ø 18,77x1,78	O-RING	JOINT TORIQUE	ANILLO DE GUARNICIÓN
2	43	1 609 500 190		VERSCHLUßSTOPFEN		OUTLET PLUG	BOUCHON	TAPON
2	44	1 609 461 470		NIPPEL		FITTING	RACCORD	RACOR
2	45	1 609 340 260		WASSERFILTER		WATER SUCTION FILTER	FILTRE	FILTRO

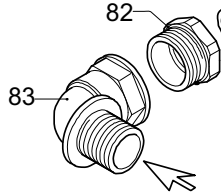
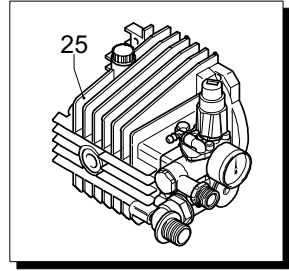
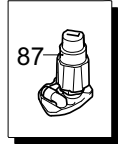
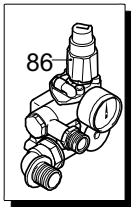
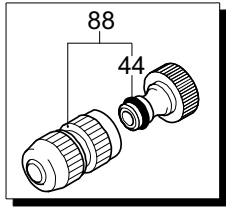
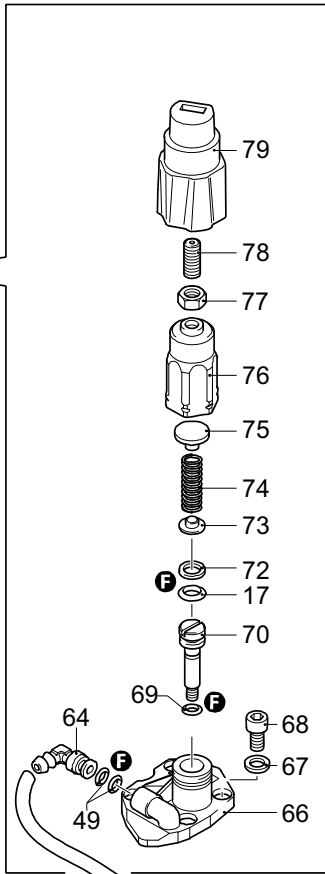
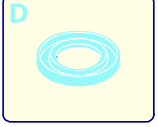
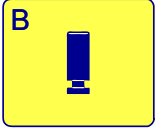
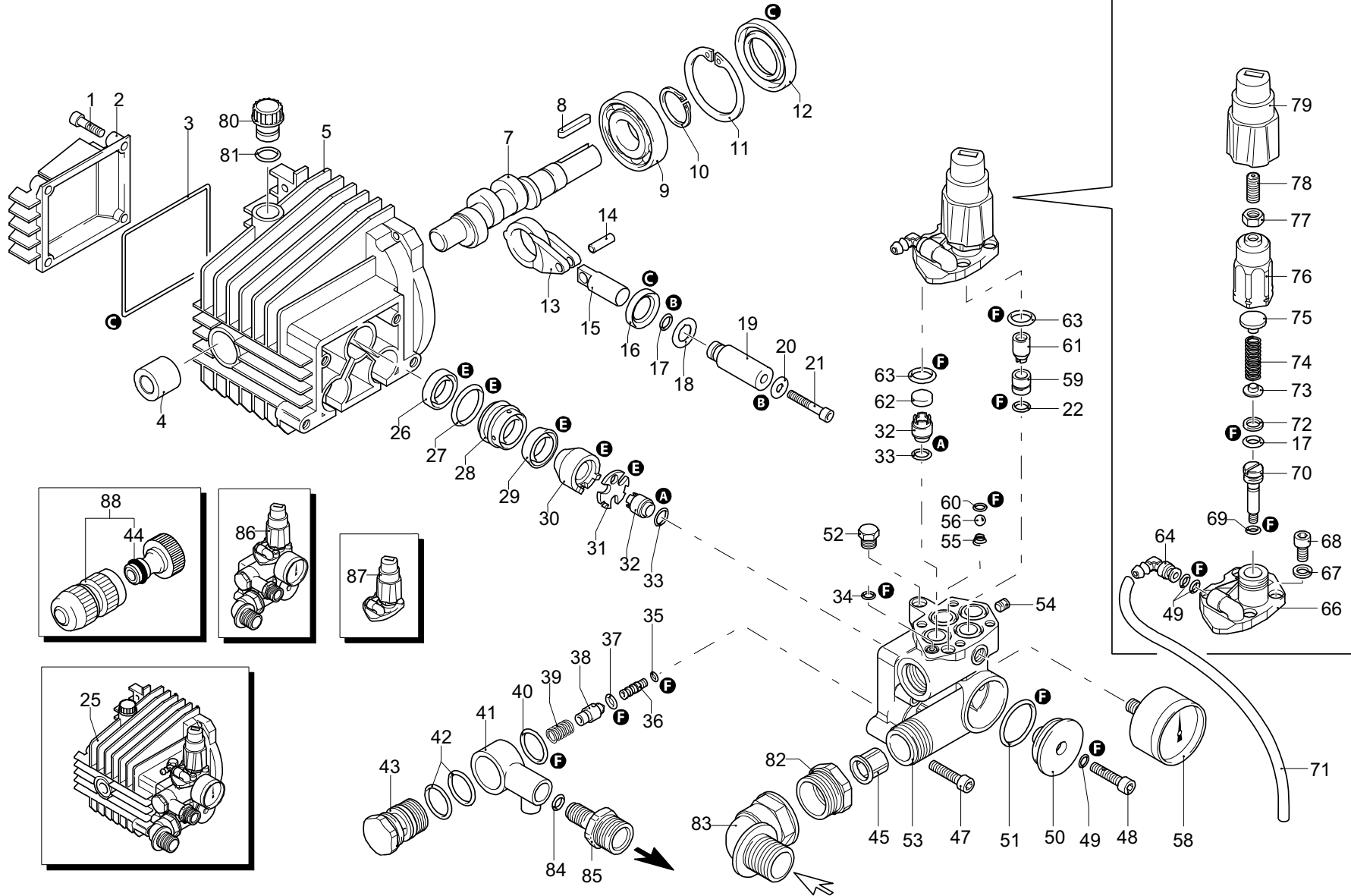

Seite / Page	Pos.	Teil-Nr. Part No. No. de pièce No. de pieza	Hinweise Notes Renseign. Nota	Bezeichnung	Spezifikation Specification	Description	Désignation	Denominación
2	47	4 609 881 470		SCHRAUBE	TCEI M6x45	SCREW	VIS	TORNILLO
2	48	1 609 680 700		SCHRAUBE	TCEI M6x20	SCREW	VIS	TORNILLO
2	49	3 609 480 480		O-RING	ø 4,48x1,78	O-RING	JOINT TORIQUE	GUARNICIÓN OR
2	50	1 609 340 190		EINLASSABDECKUNG		INLET FITTING COVER	COUVERCLE	CUBIERTA
2	51	1 609 780 050		O-RING	ø 28,25x1,78	O-RING	JOINT TORIQUE	ANILLO DE GUARNICIÓN
2	52	1 609 620 301		VERSCHLUSS	1/8" G	PLUG	BOUCHON	TAPÓN
2	53	1 609 342 670		ZYLINDERKOPF		CYLINDER HEAD	CULASSE	CULATA
2	54	1 609 851 100		GEWINDESTIFT	M 5x5	GRUB SCREW	VIS SANS TÊTE	PASADOR ROSCADO
2	55	1 609 250 270		FEDER		VALVE SPRING	RESSORT	MUELLE
2	56	1 609 250 280		KUGEL		BALL	BILLE	BOLA
2	58	1 609 003 226		MANOMETER	ø 40 mm	PRESSURE GAUGE	MANOMÈTRE	MANÓMETRO
2	59	1 609 342 700		VENTILSITZ		REGULATION VALVE SEAT	SIÈGE DE SOUPE	ASIENTO DE VÁLVULA
2	60	1 609 460 430		O-RING	ø 4x2,5	O-RING	JOINT TORIQUE	GUARNICIÓN OR
2	61	1 609 460 150		KOLBEN		PISTON	PISTON	PISTÓN
2	62	3 609 343 810		VENTILSITZ		VALVE SEAT	SIÈGE DE SOUPE	ASIENTO DE VÁLVULA
2	63	4 609 740 290		O-RING	ø 14x1,78	O-RING	JOINT TORIQUE	GUARNICIÓN OR
2	64	1 609 260 670		VERBINDUNGSSTÜCK		CONNECTOR	PIÈCE DE JONCTION	PIEZA DE UNIÓN
2	66	1 609 342 680		ZYLINDERKOPFABDECKUNG		HEAD COVER	COUVERCLE	CUBIERTA
2	67	4 609 381 550		SCHEIBE	øi 6,4	WASHER	RONDELLE	ARANDELA
2	68	4 609 343 510		SCHRAUBE	TCEI M6x14	SCREW	VIS	TORNILLO
2	69	1 609 080 190		O-RING	ø 2,90x1,78	O-RING	JOINT TORIQUE	GUARNICIÓN OR
2	70	1 609 021 900		KOLBEN		PISTON	PISTON	PISTÓN
2	71	1 609 500 330		SCHLAUCH		DETERGENT HOSE	TUBE	TUBO
2	72	1 609 080 401		RING		RING	BAGUE	ANILLO
2	73	1 609 343 450		TELLER		WOBBLE PLATE	PLATEAU	PLATILLO
2	74	1 609 460 190		FEDER		SPRING	RESSORT	RESORTE
2	75	1 609 343 000		FEDERPLATTE		SPRING PLATE	PLAQUE	PLACA
2	76	1 609 500 400		DREHGRIF, INNEN		KNOB INSERT	BOUTON DE RÉGLAGE	MANIPULADOR
2	77	1 609 060 120		MUTTER	M 6	NUT	ÉCROU	TUERCA
2	78	1 609 500 480		GEWINDESTIFT	M 6x12	GRUB SCREW	VIS SANS TÊTE	PASADOR ROSCADO
2	79	1 609 500 210		DREHGRIF, AUßEN		KNOB EXTENSION	BOUTON DE RÉGLAGE	MANIPULADOR
2	80	1 609 343 900		VERSCHLUSS		PLUG	BOUCHON	TAPÓN
2	81	1 609 880 840		O-RING	ø 9,25x1,78	O-RING	JOINT TORIQUE	GUARNICIÓN OR
2	82	1 609 180 740		ZWISCHENSTÜCK		FITTING	RACCORD	RACOR
2	83	1 609 500 280		VERLÄNGERUNG		EXTENSION	RALLONGE	ALARGADOR
2	84	1 609 480 560		O-RING	ø 6,75x1,78	O-RING	JOINT TORIQUE	ANILLO DE GUARNICIÓN
2	85	1 609 500 200		AUSLASSSTUTZEN		OUTLET FITTING	RACCORD	RACOR
2	86	1 609 042 391		PUMPE KPL. TSS		HEAD ASSEMBLY	POMPE CPL.	BOMBA CPL.
2	87	1 609 042 520		DRUCK-, WASSERMENGENREGLER		VALVE KIT ADJUSTMENT	RÉGULATEUR DE PRESSION	REGULADOR DE PRESIÓN
2	88	1 609 003 212		SCHNELLKUPPLUNG	3/4" G(F)	QUICK COUPLING	COUPLEUR RAPIDE	ACOMPLAMIENTO RÁPIDO
2	A	1 609 001 880		REP.-SATZ, VENTILSYSTEM	INC. 32,33	REPAIR KIT, VALVE	JEU DE RÉP., SOUPE	JUEGO DE REP., VÁLVULA
2	B	1 609 002 623		SATZ KOLBEN	INC. 17,19,20	PISTON KIT	KIT PISTONS	KIT PISTONES



HP-1500

2

Pumpe
Pump
Pompe
Bomba

DOLMARA member of the **Takita** Group

Seite / Page	Pos.	HP-1500	Teil-Nr. Part No. No. de pièce No. de pieza	Hinweise Notes Renseign. Nota	Bezeichnung	Spezifikation Specification	Description	Désignation	Denominación
2	C	1	609 001 876		SATZ ÖLDICHTUNGEN	INC. 3,16	OIL SEAL KIT	KIT JOINTS D'ÉTANCHÉITÉ HUILE	KIT RETENCIONES ACEITE
2	E	1	609 002 624		DICHTUNGEN, SATZ	INC. 26,27,29-31	WATER SEALS, KIT	JOINTS, JEU	JUNTAS, JUEGO
2	F	1	609 002 767		O-RINGE, SATZ	INC. 17,22,34,35,37,40,49,51,6 0,63,69,72	O-RINGS, KIT	JOINTS TORIQUE, JEU	ANILLOS DE GUARNICIÓN, JUEGO

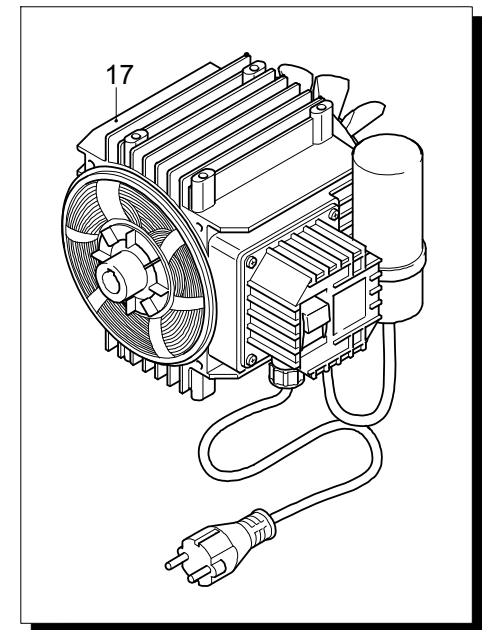
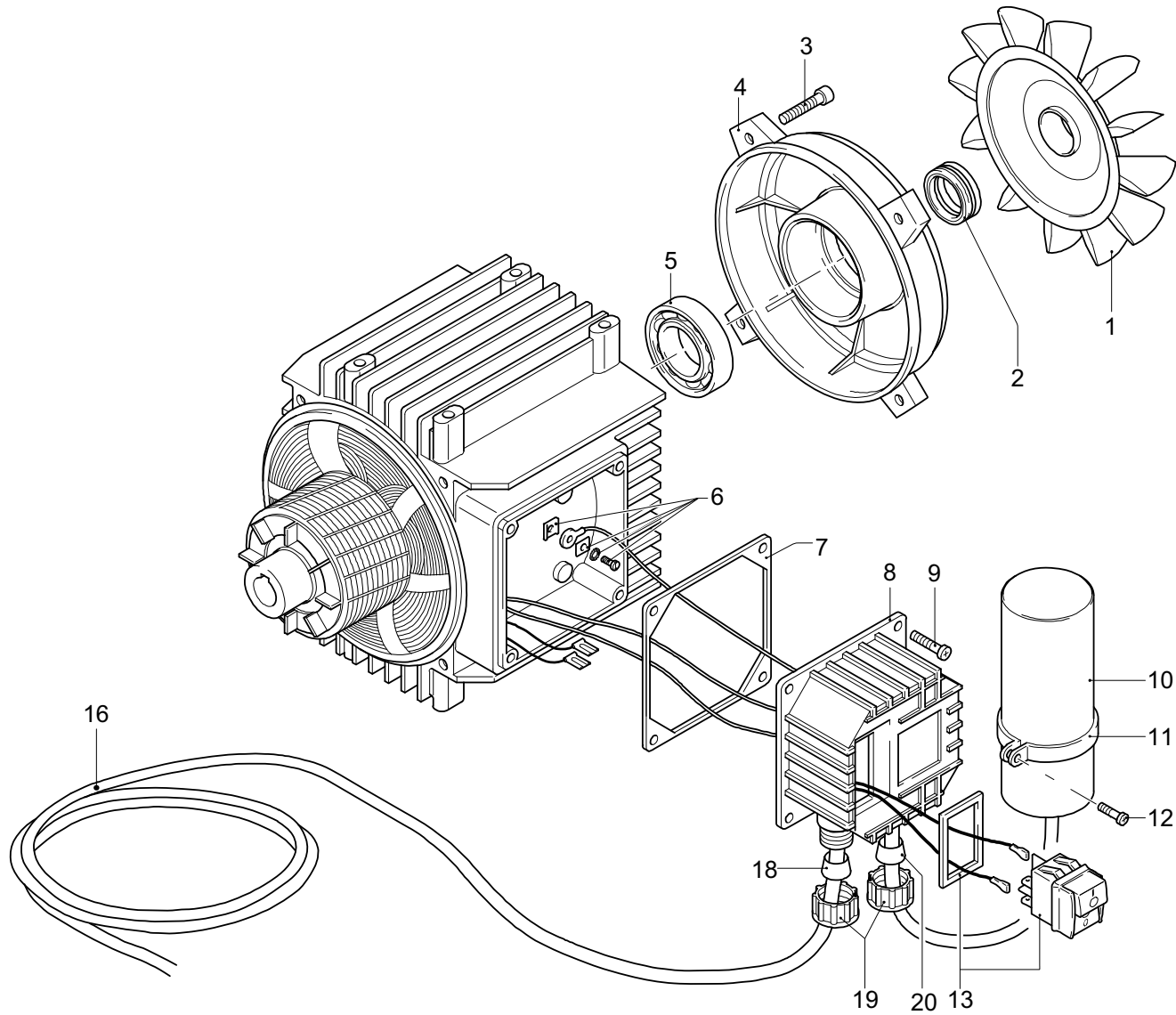

HP-1500

4

Motor
Motor
Moteur
Motor**DOLMAR**A member of the **Takita** Group

Seite / Page	Pos.	HP-1500	Teil-Nr. Part No. No. de pièce No. de pieza	Hinweise Notes Renseign. Nota	Bezeichnung	Spezifikation Specification	Description	Désignation	Denominación
4	1	1	609 260 300		LÜFTER		FAN	VENTILATEUR	VENTILADOR
4	2	1	609 340 350		ÖLDICHTUNG		OIL SEAL	ÉTANCHÉITÉ HUILE	RETENCIÓN ACEITE
4	3	4	609 260 760		SCHRAUBE	TCEI M5x20	SCREW	VIS	TORNILLO
4	4	1	609 340 320		SCHUTZSCHILD		SHIELD	BOUCLIER	ESCUDO
4	5	1	609 340 340		LAGER		BEARING	PALIER	COJINETE
4	6	1	609 269 100		KLEMME		CLAMP	ÉTAU	MORDAZA
4	7	1	609 340 780		DICHTUNG		GASKET	JOINT	GUARNICIÓN
4	8	1	609 340 480		SCHALTERGEHÄUSE		SWITCH BOX	CARTER	CÁRTER
4	9	4	609 261 560		SCHRAUBE	3,9x16	SCREW	VIS	TORNILLO
4	10	1	609 263 520		KONDENSATOR	40 µF	CAPACITOR	CONDENSATEUR	CONDENSADOR
4	11	1	609 340 280		SHELLE	only for Korea (KR)	CLAMP	COLLIER	ABRAZADERA
4	12	1	609 260 810		SCHRAUBE	TCTC M4x10 only for Korea (KR)	SCREW	VIS	TORNILLO
4	13	1	609 320 280		SCHALTER		SWITCH	INTERRUPTEUR	INTERRUPTOR
4	16	1	609 760 450		KABEL MIT STECKER	EU (SCHUKO) L=5200 mm	POWER SUPPLY CORD W. PLUG	CÂBLE AVEC PRISE	CABLE CON ENCHUFE
4	17	1	609 004 919		ELEKTROMOTOR	EU (SCHUKO)	ELECTRIC MOTOR	MOTEUR	MOTOR
4	18	1	609 340 660		GUMMIFUß		RUBBER FOOT	CAPSULE CAOUTCHOUC	GOMA
4	19	2	609 340 640		NUTMUTTER		RING NUT	ÉCROU	VIROLA
4	20	1	609 340 650		GUMMIFUß		RUBBER FOOT	CAPSULE CAOUTCHOUC	GOMA

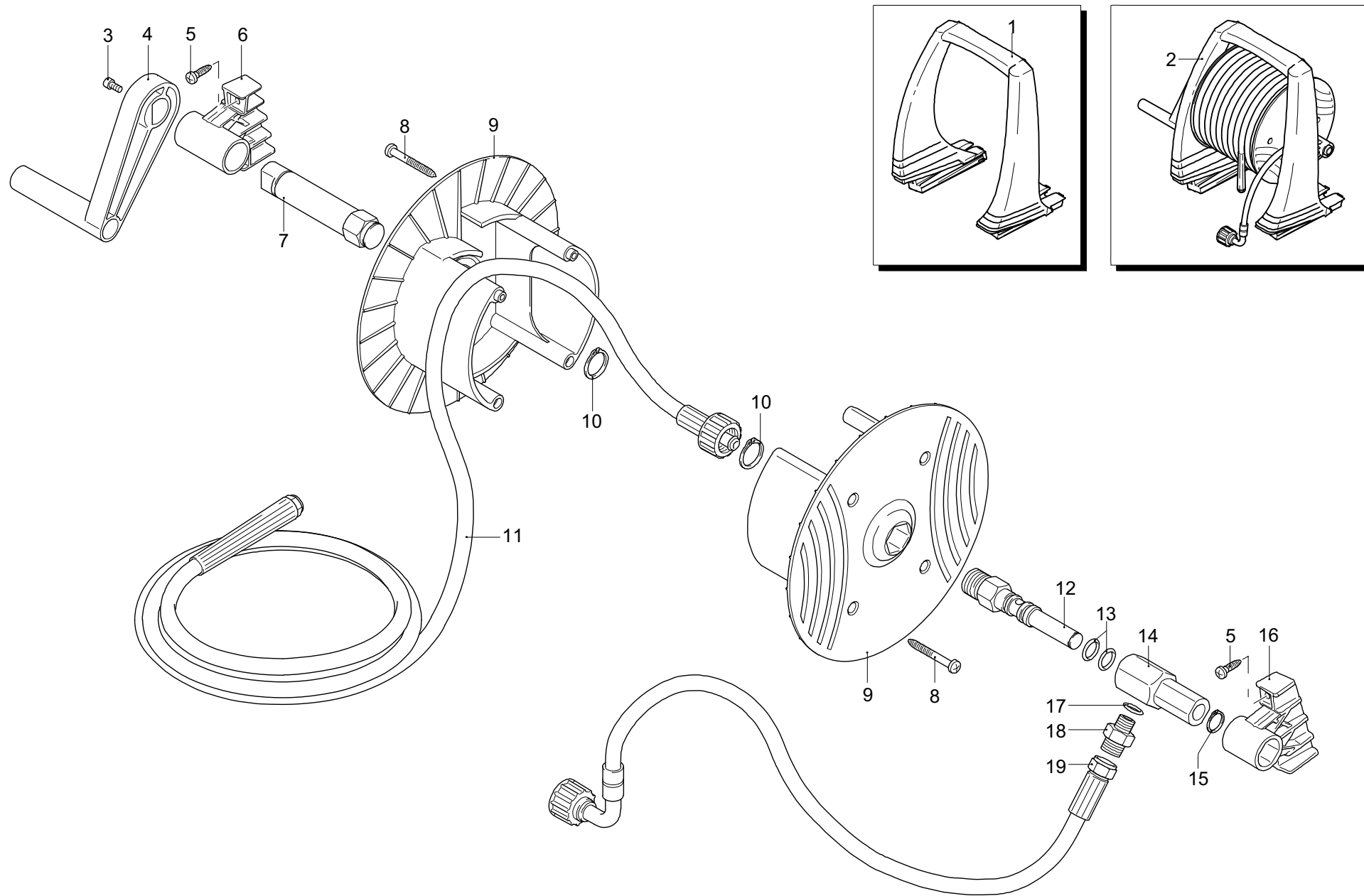

HP-1500

5

Schlauchtrommel
Hose reel
Tambour de tuyau
Tambor para mangas

DOLMARA member of the **Takita** Group

Seite / Page	Pos.	Teil-Nr. Part No. No. de pièce No. de pieza	Hinweise Notes Renseign. Nota	Bezeichnung	Spezifikation Specification	Description	Désignation	Denominación
5	1	1 609 500 020		GRIFF		HANDLE	POIGNÉE	MANGO
5	2	1 609 509 003		SCHLAUCHTROMMEL KPL.	INC. 1,3-19	HOSE REEL ASSEMBLY	TAMBOUR DE TUYAU CPL.	TAMBOR PARA MANGAS CPL.
5	3	1 609 360 360		SCHRAUBE	TCEI M5x10	SCREW	VIS	TORNILLO
5	4	1 609 360 150		KURBEL		CRANK LEVER	MANIVELLE	MANIVELA
5	5	4 609 100 300		SCHRAUBE	5x16	SCREW	VIS	TORNILLO
5	6	1 609 500 060		ACHSLAGER LINKS		AXLE BEARING, LEFT	PALIER, GAUCHE	COJINETE DEL EJE, IZQ.
5	7	1 609 500 360		ACHSE LINKS		AXLE, LEFT	AXE, GAUCHE	EJE, IZQ.
5	8	4 609 681 280		SCHRAUBE	4,2x50	SCREW	VIS	TORNILLO
5	9	2 609 360 230		SCHLAUCHTROMMEL		HOSE REEL	TAMBOUR DE TUYAU	TAMBOR PARA MANGAS
5	10	2 609 380 420		SICHERUNGSRING	øe 22	RETAINING RING	CIRCLIP	ANILLO SEGURIDAD
5	11	1 609 040 858		HOCHDRUCKSCHLAUCH	15 m	HIGH PRESSURE HOSE	TUYAU HAUTE PRESSION	TUBO
5	12	1 609 360 210		ACHSE RECHTS		AXLE, RIGHT	AXE, DROITE	EJE, DERECHA
5	13	2 609 390 080		O-RING	ø 11,91x2,62	O-RING	JOINT TORIQUE	GUARNICIÓN OR
5	14	1 609 360 220		VERBINDUNGSSTÜCK		FITTING	RACCORD	RACOR
5	15	1 609 360 320		SICHERUNGSRING	øe 14	CIRCLIP	CIRCLIP	ANILLO SEGURIDAD
5	16	1 609 500 070		ACHSLAGER RECHTS		AXLE BEARING, RIGHT	PALIER, DROITE	COJINETE DEL EJE, DERECHA
5	17	1 609 820 510		O-RING	ø 10,82x1,78	O-RING	JOINT TORIQUE	GUARNICIÓN OR
5	18	1 609 360 310		VERBINDUNGSSTÜCK	1/4"-3/4"G (M)	CONNECTOR	ADAPTEUR	PIEZA DE UNIÓN
5	19	1 609 360 250		SCHLAUCH		HOSE	TUYAU	TUBO

HP-1500

6

Zubehör
Accessories
Accessoires
Accesorios

DOLMAR
A member of the *Trakita* Group

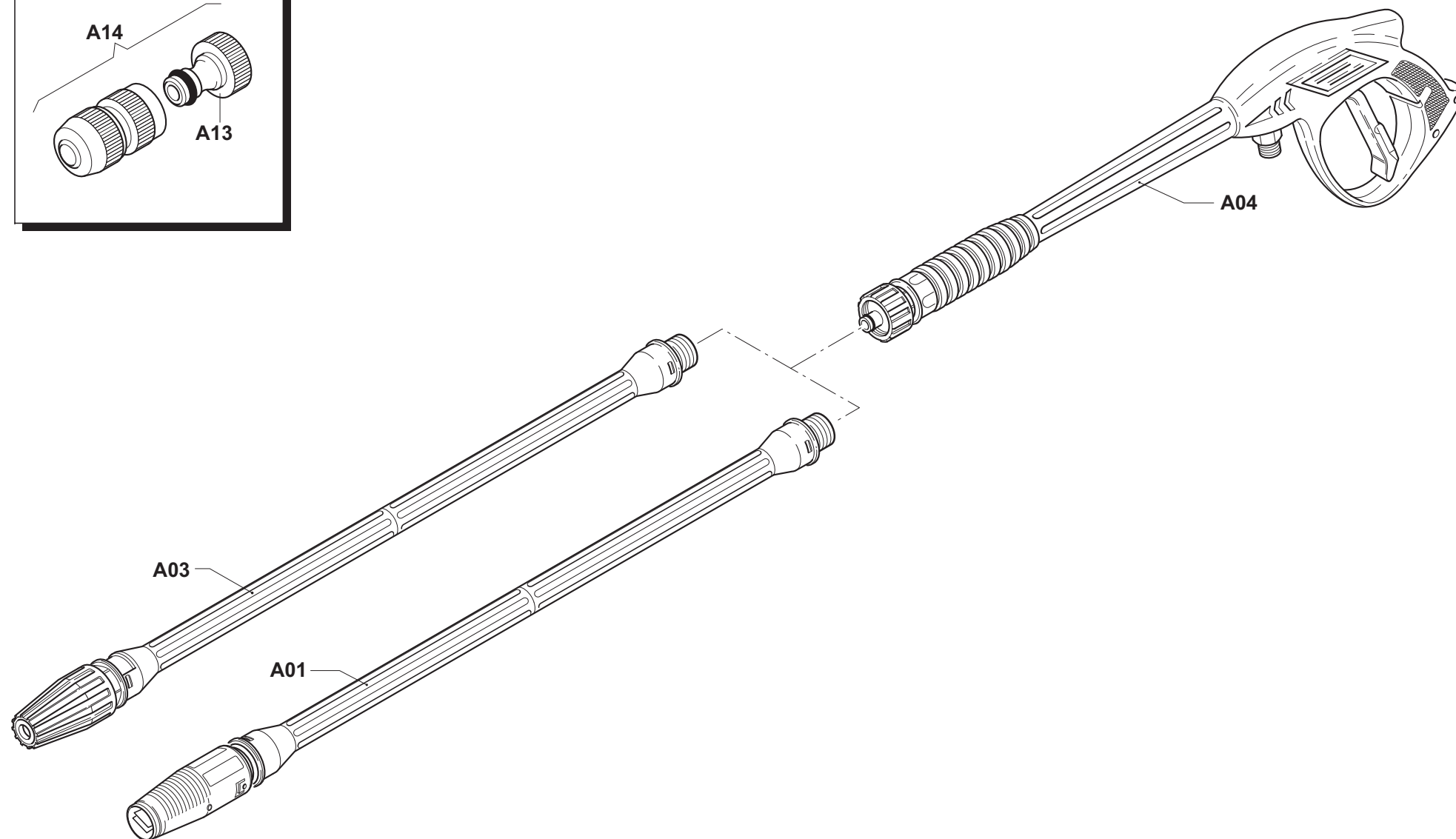
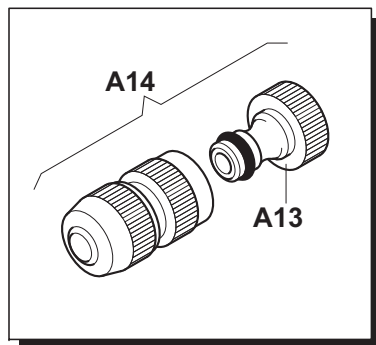

HP-1500

6

Zubehör
Accessories
Accessoires
Accesorios**DOLMAR**A member of the **Makita** Group

Seite / Page	Pos.	HP-1500	Teil-Nr. Part No. No. de pièce No. de pieza	Hinweise Notes Renseign. Nota	Bezeichnung	Spezifikation Specification	Description	Désignation	Denominación
6	A01	1	609 040 886		LANZE MIT ARRETIERBARER DÜSE		ADJUSTABLE SPRAY LANCE	LANCE	LANZA
6	A03	1	609 040 169		TURBOLANZE		ROTO POWER PRO	LANCE, TURBO	LANZA, TURBO
6	A04	1	609 040 925		SPRÜHHANDGRIFF		SPRAY HANDLE	POIGNÉE-GÂCHETTE	MANGO PULVERIZADOR
6	A13	1	609 461 470		NIPPEL		FITTING	RACCORD	RACOR
6	A14	1	609 040 853		SCHNELLKUPPLUNG	3/4" G(F) INC. A13	QUICK COUPLING	COUPLEUR RAPIDE	ACOMPLAMIENTO RÁPIDO

HP-1500

	Zeichenerklärung	Key to symbols	Légende	Explicación de símbolos
=> 1999999 2000000 => 2003.04 => TI 2003/07 Acc. = { m Corr.	Produktion bis Serien-Nr. Neues Teil ab Serien-Nr. Neues Teil ab Jahr / Monat Siehe Technische Information Jahr / Nr. Zubehör (nicht im Lieferumfang) Keine Serienausführung, jedoch verwendbar Beinhaltet Positions-Nr. Meterware Druckfehlerberichtigung	Production to serial number New part from serial number New part from Year / Month See Technical Information Year / No. Accessories (not included in the delivery inventory) No standard execution, may be used Contains item number Sold by the meter Error correction	Production jusqu'à n° de série Nouvelle pièce à partir du n° de série Nouvelle pièce à partir de année / mois Voir information technique année / n° Accessoires (non compris dans la livraison) Aucune exécut. en série, cependant utilisable contient n° de numéro Au mètre Rectification d'erreurs	Producción hasta N° de serie Pieza nueva a partir de N° de serie Pieza nueva a partir de año / mes Véase inform. técnico año / N° Accesorios (no incluido en la extensión del suministro) No es de serie, pero sirve Contiene pos N° Por metro Fe de erratas
	Änderungen vorbehalten	Specifications subject to change without notice	Changements sans préavis	Mejoras constructivas sin previo aviso