

Spare Parts List  
Ersatzteilliste  
Liste de pièces détachées  
Lista de piezas de repuesto

2014-08

PM-5120  
PM-5120 S

---

**DOLMAR**



A member of the *Makita* Group

PM-5120, PM-5120 S (D, GB, F, E)

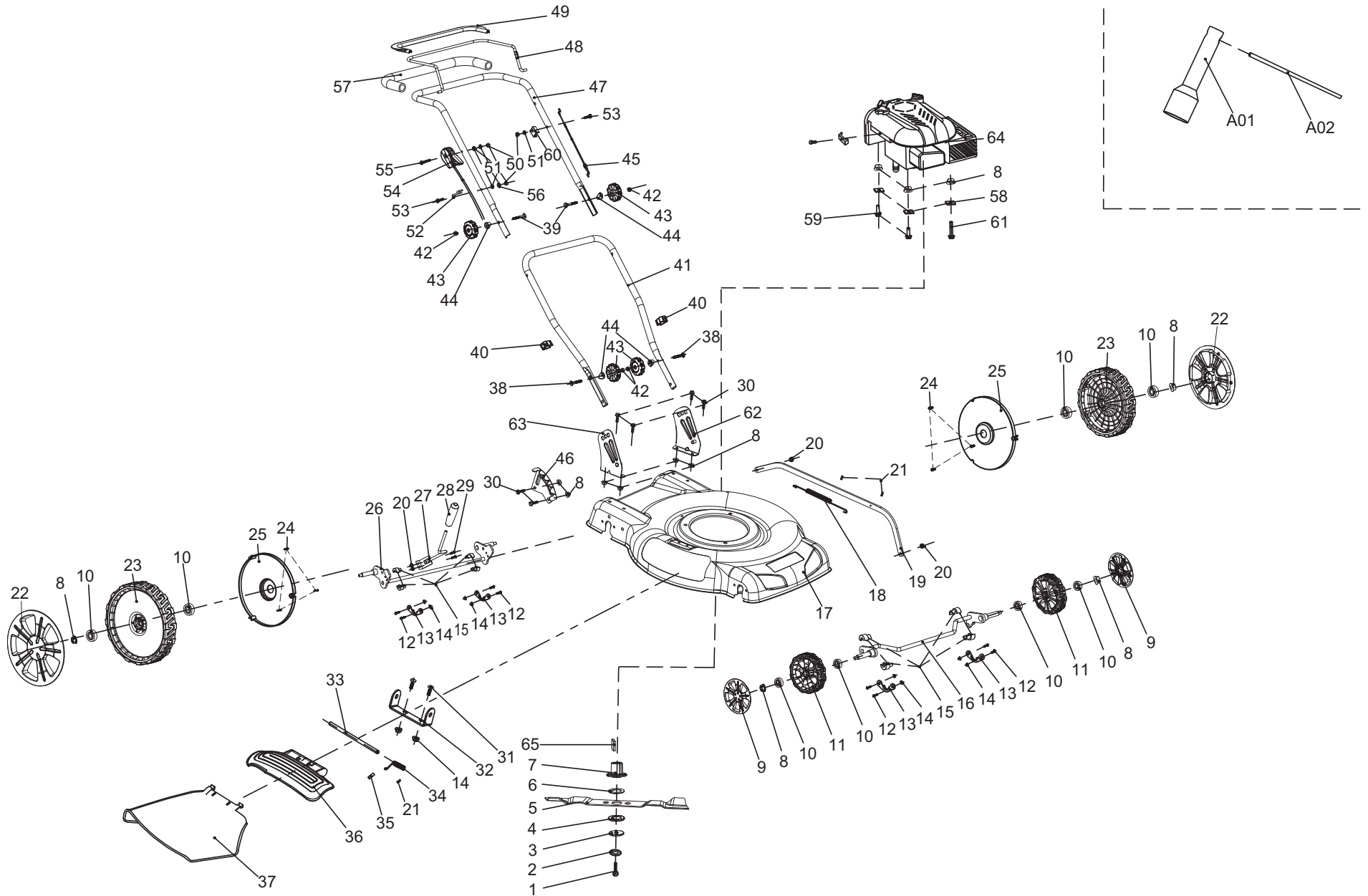

Seite / Page	Pos.	Teil-Nr. Part No. No. de pièce No. de pieza	Hinweise Notes Renseign. Nota	Bezeichnung	Spezifikation Specification	Description	Désignation	Denominación
1	1	1 671 006 062		MESSERSCHRAUBE	3/8", L=40mm	BLADE TIGHTEN SCREW	VIS DE LAME	TORNILLO DE LA CUCHILLA
1	2	1 671 010 730		SCHEIBE	Φ44.5/10.2x2.5	LID SHAPE WASHER	RONDELLE	ARANDELA
1	3	1 671 002 050		DRUCKSCHEIBE		PRESSING PLATE	DISQUE DE PRESSION	DISCO DE PRESION
1	4	1 671 717 001		UNTERE DRUCKSCHEIBE		LOWER PRESSING PLATE	DISQUE DE PRESSION	DISCO DE PRESION
1	5	1 671 001 826		MESSER	510mm	BLADE	LAME	CUCHILLA ESTÁNDAR
1	6	1 671 716 001		OBERE DRUCKSCHEIBE		UPPER PRESSING PLATE	DISQUE DE PRESSION	DISCO DE PRESION
1	7	1 671 002 051		MESSERHALTER		BLADE SUPPORT	MOYEU	SOPORTE DE LA CUCHILLA
1	8	13 671 005 028		6KT-MUTTER	M8	HEXAGONAL LOCKING NUT	ECROU HEXAGONAL	TUERCA HEXAGONAL
1	9	2 671 001 177		RADKAPPE	8"	WHEEL COVER	CHAPEAU DE MOYEU	CAPERUZA DE RUEDA
1	10	8 671 004 012		KUGELLAGER	6201Z	BALL BEARING	ROULEMENT À BILLES	RODAMIENTO DE BOLAS
1	11	2 671 020 160		RAD	8"	WHEEL ASSY.	ROUE	RUEDA
1	12	8 671 002 019		SCHRAUBE	M6x12	TRIGGER BOLT	VIS	TORNILLO
1	13	4 671 001 244		FIXIERUNG		RING OF AXLE FIXING	FIXATION	FIJACIÓN
1	14	10 671 005 024		6KT-MUTTER	M6	HEXAGONAL LOCKING NUT	ECROU HEXAGONAL	TUERCA HEXAGONAL
1	15	8 671 340 001		LAGERSCHALE		BEARING SHELL	COQUILLE DE COUSSINET	CASQUILLO DE COJINETE
1	16	1 671 001 811		VORDERACHSE	20"	FRONT WHEEL AXLE	ESSIEU AVANT	EJE DELANTERO
1	17	1 671 001 601		GEHÄUSE ROT	20" DOLMAR red	DECK RED	CHÂSSIS ROUGE	CARCASA ROJA
1	18	1 671 011 039		FEDER		SPRING	RESSORT	MUELLE
1	19	1 671 001 827		VERBINDUNGSSTANGE		CONNECTION ROD	BARRE DE RACCORDEMENT	BARRA DE CONEXIÓN
1	20	4 671 005 005		6KT-MUTTER	M6	LOCKING NUT	ECROU	TUERCA
1	21	3 671 300 101		SCHRUMPFSCHLAUCH	Φ3mm	HEAT SHRINKABLE TUBE	TUBE FLEXIBLE THERMORÉTRACTABLE	TUBO TERMORRETRACTIL
1	22	2 671 001 322		RADKAPPE		WHEEL COVER	CHAPEAU DE MOYEU	CAPERUZA DE RUEDA
1	23	2 671 002 021		RAD KPL.		WHEEL ASSY.	ROUE CPL.	RUEDA CPL.
1	24	6 671 001 005		SCHRAUBE SELBSTSCHNEIDEND	4x16	SELF-TAPPING SCREW	VIS DE FORAGE	TORNILLO PERFORADOR
1	25	2 671 666 001		STAUBSCHUTZSCHEIBE		DUST COVER	PROTEGE-POUSSIÈRE	CUBIERTA GUARDAPOLVO
1	26	1 671 001 828		HINTERRADACHSE	20"	REAR WHEEL AXLE	AXE ROUE ARRIERES	EJE RUEDAS TRASERAS
1	27	1 671 010 450		HEBEL, HÖHENVERSTELLUNG UND GRIFFUMHÜLLUNG KPL.	INC. 27,28	LEVER, HEIGHT ADJUSTMENT CPL.	LEVIER, REGLAGE HAUTEUR CPL.	PALANCA, AJUSTE ALTURA CPL.
1	28	1 671 010 450		HEBEL, HÖHENVERSTELLUNG UND GRIFFUMHÜLLUNG KPL.	INC. 27,28	LEVER, HEIGHT ADJUSTMENT CPL.	LEVIER, REGLAGE HAUTEUR CPL.	PALANCA, AJUSTE ALTURA CPL.
1	29	2 671 002 030		SCHRAUBE	M6x14	TRIGGER BOLT	VIS	TORNILLO
1	30	6 671 006 064		6KT-SCHRAUBE	M8x6	HEXAGON HEAD BOLT	VIS À SIX PANS	TORNILLO HEXAGONAL
1	31	2 671 002 020		SCHRAUBE	M6x16	TRIGGER BOLT	VIS	TORNILLO
1	32	1 671 002 233		DRUCKPLATTE		PRESSURE PLATE	PLAQUE DE PRESSION	PLACA DE PRÉSION
1	33	1 671 010 300		ACHSE		AXLE	AXE	EJE
1	34	1 671 011 135		FEDER	Φ2.8	SPRING	RESSORT	MUELLE
1	35	1 671 003 003		SCHRUMPFSCHLAUCH	Φ6mm	HEAT SHRINKABLE TUBE	TUBE FLEXIBLE THERMORÉTRACTABLE	TUBO TERMORRETRACTIL
1	36	1 671 497 001		MULCHABDECKUNG		SIDE DISCHARGE COVER	COUVERCLE	CUBIERTA
1	37	1 671 546 001		SCHUTZHAUBE SEITENAUSWURF	20"	PROTECTION COVER	CAPOT DE PROTECTION	CUBIERTA PROTECTORA
1	38	2 671 006 091		SCHRAUBE	M8X40	BOLT	VIS	TORNILLO

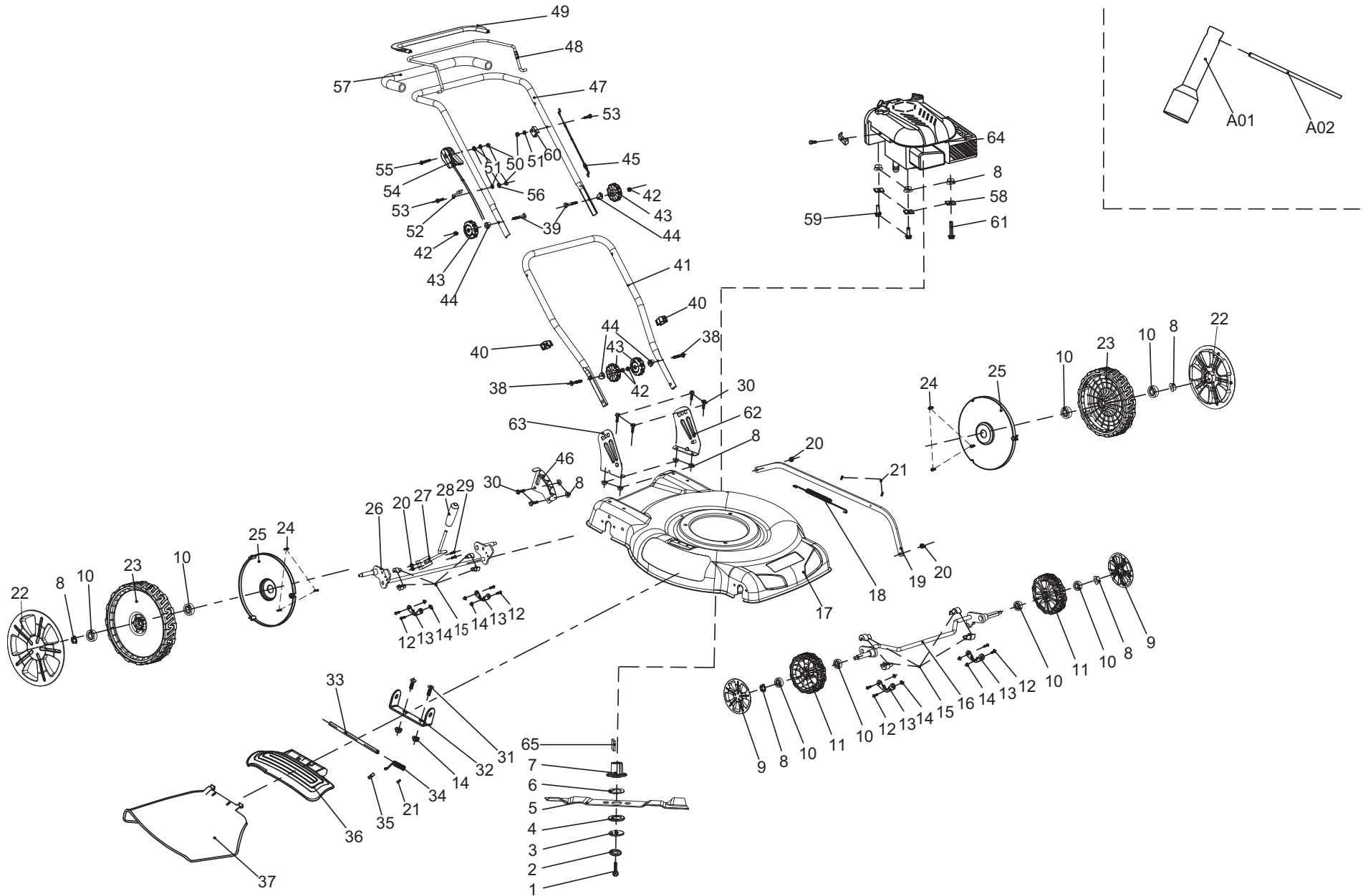

Seite / Page	Pos.	Teil-Nr. Part No. No. de pièce No. de pieza	Hinweise Notes Renseign. Nota	Bezeichnung	Spezifikation Specification	Description	Désignation	Denominación
1	39	2 671 006 004		FLACHKOPFSCHRAUBE	M8x52	FLAT HEAD BOLT	VIS À TÊTE CYLINDRIQUE	TORNILLO DE CABEZA PLANA
1	40	2 671 177 001		KABELCLIPP		CABLE CLIP	CLIP DE CÂBLE	CLIP PARA CABLE
1	41	1 671 001 841		UNTERHOLM		LOWER HANDLE	MANCHE INFÉRIEURE	MANGO INFERIOR
1	42	4 671 005 007		MUTTER	M8	NUT	ECROU	TUERCA
1	43	4 671 453 001		STERNGRIF		STAR KNOB	MANETTE	MANIJA DE ESTRELLA
1	44	4 671 001 085		SCHEIBE		WASHER	RONDELLE	ARANDELA
1	45	1 671 012 160		BOWDENZUG (MOTORBREMSE)		CONTROL CABLE (MOTOR BRAKE)	CÂBLE BOWDEN (FREIN MOTEUR)	TRACCIÓN BOWDEN (FRENO MOTOR)
1	46	1 671 001 710		SEKTOR, HÖHENVERSTELLUNG	20"	SECTOR, HEIGHT ADJUSTMENT	SECTEUR REGLAGE HAUTEUR	SECTOR, AJUSTE ALTURA
1	47	1 671 001 836		HOLM, OBERTEIL		HANDLE, UPPER PART	MANCHERON, PARTIE SUPERIEURE	MANILLAR, PARTE SUPERIOR
1	48	1 671 001 816		HEBEL, MOTORBREMSE		LEVER, MOTOR BRAKE	LEVIER FREIN MOTEUR	PALANCA, FRENO MOTOR
1	49	2 671 687 001		HANDGRIF		CLAMP PLATE	POIGNÉE	MANGO
1	50	3 671 005 016		6KT-MUTTER	M6	HEX. LOCK NUT	ECROU	TUERCA
1	51	3 671 007 008		SCHEIBE	φ16xφ8x0,8	WASHER	RONDELLE	ARANDELA
1	52	1 671 001 647		HAKEN		CABLE HOOK	TENON	GANCHO
1	53	2 671 006 077		SCHRAUBE	M6x35	BOLT	VIS	TORNILLO
1	54	1 671 010 620		MOTORFERNBEDIENUNG INKL. BOWDENZUG		THROTTLE HANDLE ASS'Y	LEVIER / CABLE, ACCELERATEUR	PALANCA / CABLE, ACELERADOR
1	55	1 671 006 059		SCHRAUBE	M6x50	BOLT	VIS	TORNILLO
1	56	2 671 008 003		FEDERSCHEIBE	φ6,65	SPRING WASHER	RONDELLE A RESSORT	ARANDELA ELASTICO
1	57	1 671 101 901		GRIFFUMHÜLLUNG	φ22xφ32x580	HANDLE SHEATH	POIGNÉE	EMPUÑADURA
1	58	3 671 002 106		4KT-SCHEIBE	φ10	SQUARE GASKET	RONDELLE	ARANDELA
1	59	2 671 006 025		6KT-SCHRAUBE	M8x35	HEXAGON BOLT	VIS À SIX PANS	TORNILLO HEXAGONAL
1	60	1 671 336 001		HALTERUNG		FIXED BRACKET	FIXATION	SOPORTE
1	61	1 671 006 079		6KT-SCHRAUBE	M8x60	HEXAGON HEAD BOLT	VIS À SIX PANS	TORNILLO HEXAGONAL
1	62	1 671 001 599		GRIFFANBINDUNG, LINKS	20" DOLMAR red	BRACKET HANDLE, LEFT	BRIDE DE POIGNÉE, GAUCHE	FIJACIÓN DE MANGO, IZQ.
1	63	1 671 001 600		GRIFFANBINDUNG, RECHTS	20" DOLMAR red	BRACKET HANDLE, RIGHT	BRIDE DE POIGNÉE, DROITE	FIJACIÓN DE MANGO, DERECHA
1	64	1		MOTOR	625E/190CC/2.7KW/3000rpm,B&S,XLS black cover,short	ENGINE	MOTEUR	MOTOR
1	65	1 671 090 018		PASSFEDER	4.77*4.77*35	FLAT KEY	CLAVETTE	CHAVETA
1	A01	1 671 001 078		STECKSCHLÜSSEL	21mm	BOX SPANNER	CLÉ À DOUILLE	LLAVE
1	A02	1 671 001 079		SPANNSTANGE	Φ8x110mm	SPANNER POLE	TIRANT	TENSOR

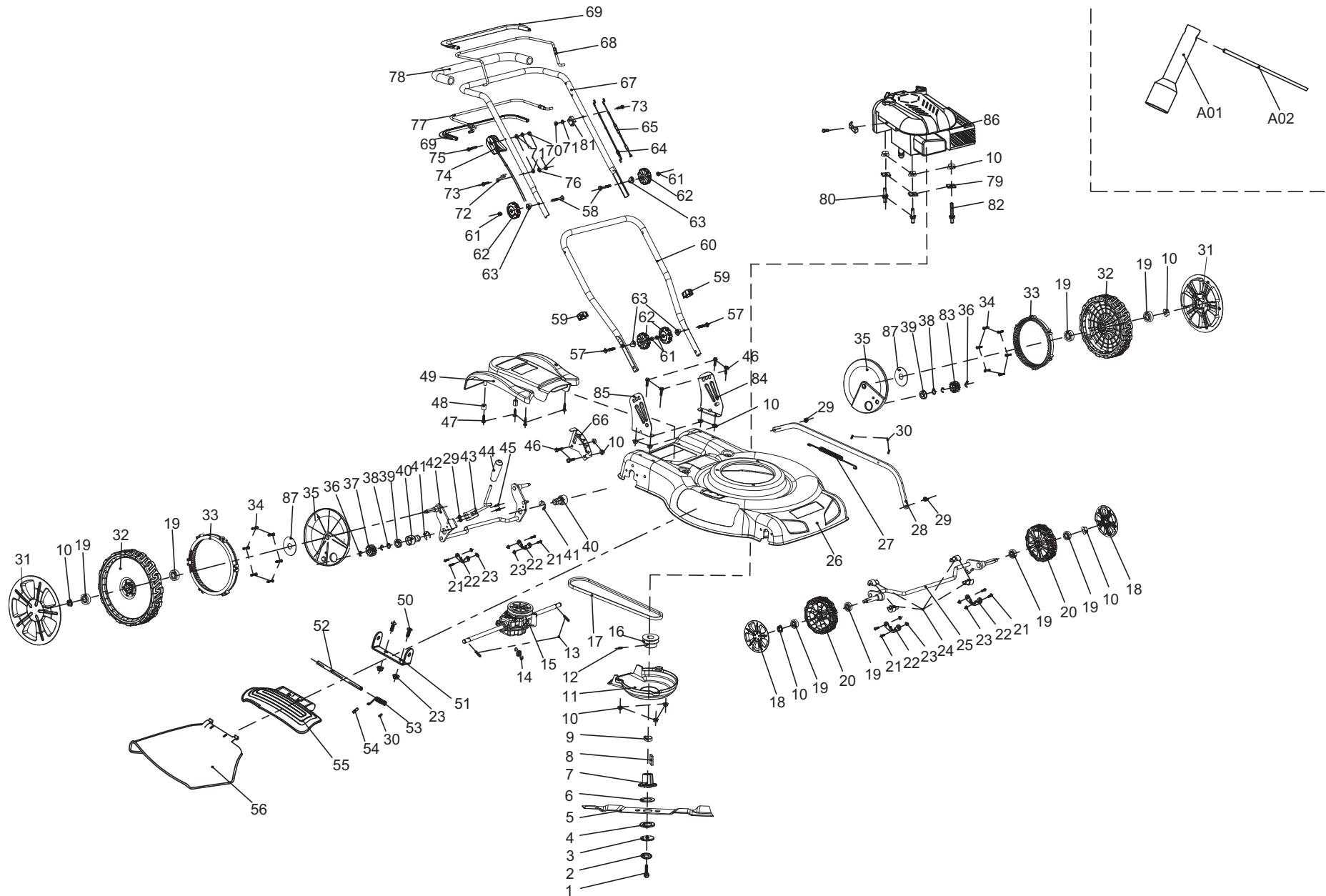

Seite / Page	Pos.	PM-5120 S	Teil-Nr. Part No. No. de pièce No. de pieza	Hinweise Notes Renseign. Nota	Bezeichnung	Spezifikation Specification	Description	Désignation	Denominación
2	1	1	671 006 141		MESSERSCHRAUBE	3/8" 24UNF, L=55mm	BLADE TIGHTEN BOLT	VIS DE LAME	TORNILLO DE LA CUCHILLA
2	2	1	671 010 730		SCHEIBE	Φ44.5/10.2x2.5	LID SHAPE WASHER	RONDELLE	ARANDELA
2	3	1	671 002 050		DRUCKSCHEIBE		PRESSING PLATE	DISQUE DE PRESSION	DISCO DE PRESION
2	4	1	671 717 001		UNTERE DRUCKSCHEIBE		LOWER PRESSING PLATE	DISQUE DE PRESSION	DISCO DE PRESION
2	5	1	671 001 826		MESSER	510mm	BLADE	LAME	CUCHILLA ESTÁNDAR
2	6	1	671 716 001		OBERE DRUCKSCHEIBE		UPPER PRESSING PLATE	DISQUE DE PRESSION	DISCO DE PRESION
2	7	1	671 002 049		MESSERHALTER		BLADE SUPPORT	MOYEU	SOPORTE DE LA CUCHILLA
2	8	1	671 090 002		PASSFEDER	4.8*4.7*46.5	FLAT KEY	CLAVETTE	CHAVETA
2	9	1	671 319 001		HÜLSE	12mm	BLADE LINING SHEATH	DOUILLE	CASQUILLO
2	10	16	671 005 028		6KT-MUTTER	M8	HEXAGONAL LOCKING NUT	ECROU HEXAGONAL	TUERCA HEXAGONAL
2	11	1	671 688 001		RIEMENABDECKUNG		BELT COVER	COUVERCLE DE COURROIE	CUBIERTA DE CORREA
2	12	1	671 030 050		6KT-SCHRAUBE	M6x8	HEXAGON HEAD BOLT	VIS À SIX PANS	TORNILLO HEXAGONAL
2	13	2	671 090 001		ZYLINDERSTIFT	Φ5x21.5	CYLINDRICAL PIN	GOUPILLE CYLINDRIQUE	PASADOR CILINDRICO
2	14	1	671 011 173		FEDER		GEAR BOX SPRING	RESSORT	MUELLE
2	15	1	671 502 015		ANTRIEB	20"	GEAR BOX	GROUPE TRACTION	UNIDAD DE TRACCIÓN
2	16	1	671 004 016		KEILRIEMENSCHLEIBE		V-BELT PULLEY	POULIE À COURROIE	POLEA DE CORREA
2	17	1	671 020 380		KEILRIEMEN	Li=813mm	V-BELT	COURROIE TRAPÉZOIDALE	CORREA TRAPEZOIDAL
2	18	2	671 001 177		RADKAPPE	8"	WHEEL COVER	CHAPEAU DE MOYEU	CAPERUZA DE RUEDA
2	19	8	671 004 012		KUGELLAGER	6201Z	BALL BEARING	ROULEMENT À BILLES	RODAMIENTO DE BOLAS
2	20	2	671 020 160		RAD	8"	WHEEL ASSY.	ROUE	RUEDA
2	21	8	671 002 019		SCHRAUBE	M6x12	TRIGGER BOLT	VIS	TORNILLO
2	22	4	671 001 244		FIXIERUNG		RING OF AXLE FIXING	FIXATION	FIJACIÓN
2	23	10	671 005 024		6KT-MUTTER	M6	HEXAGONAL LOCKING NUT	ECROU HEXAGONAL	TUERCA HEXAGONAL
2	24	4	671 340 001		LAGERSCHALE		BEARING SHELL	COQUILLE DE COUSSINET	CASQUILLO DE COJINETE
2	25	1	671 001 811		VORDERACHSE	20"	FRONT WHEEL AXLE	ESSIEU AVANT	EJE DELANTERO
2	26	1	671 001 602		GEHÄUSE ROT	20" DOLMAR red	DECK RED	CHÂSSIS ROUGE	CARCASA ROJA
2	27	1	671 011 039		FEDER		SPRING	RESSORT	MUELLE
2	28	1	671 001 813		VERBINDUNGSSTANGE	20"	CONNECTION ROD	BARRE DE RACCORDEMENT	BARRA DE CONEXIÓN
2	29	4	671 005 005		6KT-MUTTER	M6	LOCKING NUT	ECROU	TUERCA
2	30	3	671 300 101		SCHRUMPFSCHLAUCH	Φ3mm	HEAT SHRINKABLE TUBE	TUBE FLEXIBLE THERMORÉTRACTABLE	TUBO TERMORRETRACTIL
2	31	2	671 001 322		RADKAPPE		WHEEL COVER	CHAPEAU DE MOYEU	CAPERUZA DE RUEDA
2	32	2	671 002 021		RAD KPL.		WHEEL ASSY.	ROUE CPL.	RUEDA CPL.
2	33	2	671 200 010		ZAHNRAD	11"	GEAR WHEEL	ROUE DENTEE	PIÑÓN
2	34	12	671 001 005		SCHRAUBE SELBSTSCHNEIDEND	4x16	SELF-TAPPING SCREW	VIS DE FORAGE	TORNILLO PERFORADOR
2	35	2	671 180 010		RAD-INNENABDECKUNG	11"	INNER WHEEL COVER	CHAPEAU DE MOYEU	CAPERUZA DE RUEDA
2	36	4	671 090 020		SICHERUNGSSCHEIBE		SAFETY WASHER	RONDELLE SÉCURITÉ	ARANDELA SEGURIDAD
2	37	1	671 003 002		ZAHNRAD, RECHTS		RIGHT GEAR	ROUE DENTEE, DROITE	PIÑÓN, DERECHA
2	38	2	671 007 059		FLACHSCHEIBE	Φ12.8*Φ20*1.2	FLAT WASHER	RONDELLE PLATE	ARANDELA
2	39	2	671 004 023		LAGER		BEARING	ROULEMENT	RODAMIENTO
2	40	2	671 002 035		LAGERGEHÄUSE		BEARING HOUSING	CARTER	CÁRTER
2	41	2	671 009 003		SICHERUNGSSCHEIBE	Φ19x1.5	SAFETY WASHER	RONDELLE SÉCURITÉ	ARANDELA SEGURIDAD



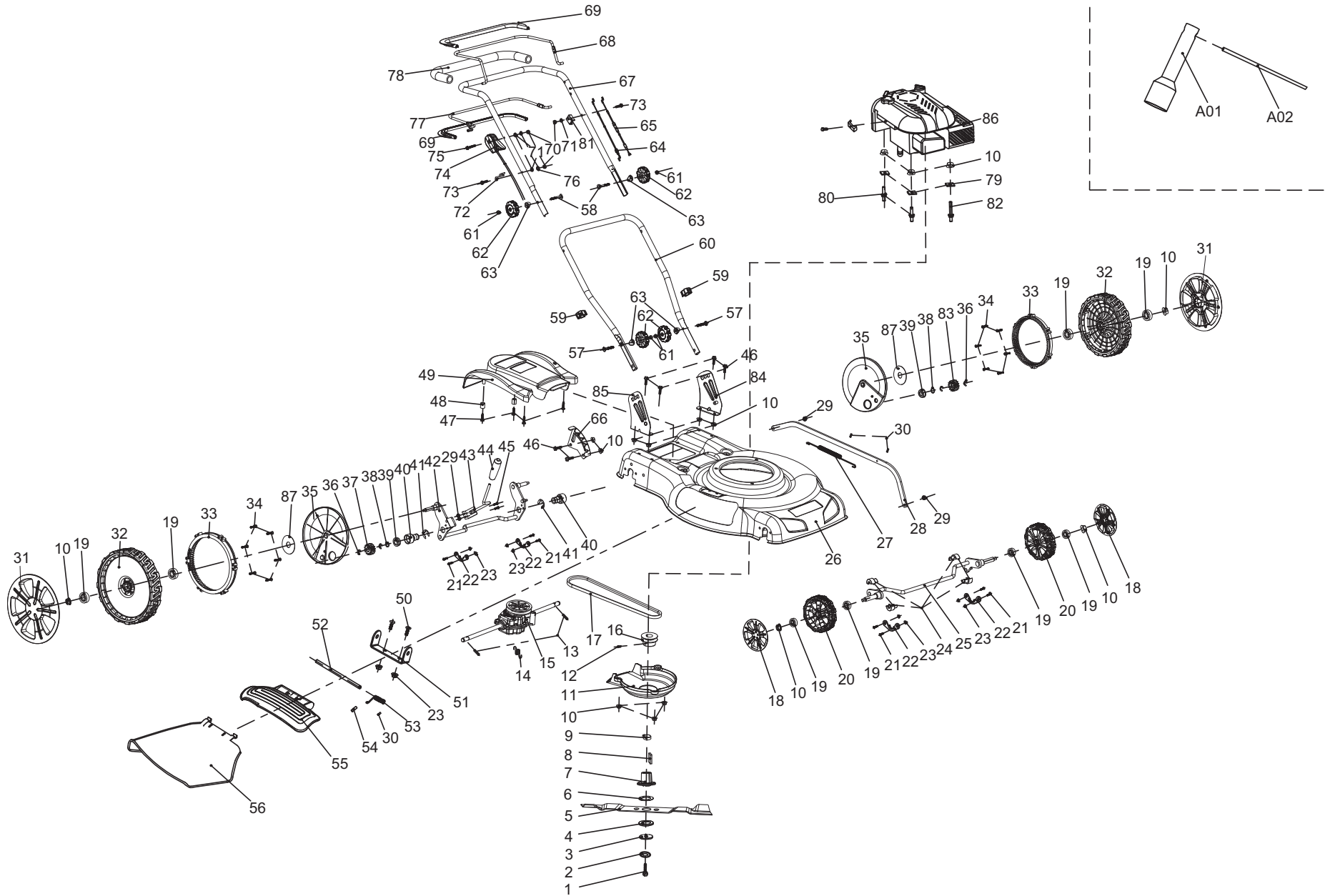



Seite / Page	Pos.	PM-5120 S	Teil-Nr. Part No. No. de pièce No. de pieza	Hinweise Notes Renseign. Nota	Bezeichnung	Spezifikation Specification	Description	Désignation	Denominación
2	42	1	671 001 812		HINTERRADACHSE	20"	REAR WHEELS AXLE	AXE ROUE ARRIERES	EJE RUEDAS TRASERAS
2	43	1	671 010 450		HEBEL, HÖHENVERSTELLUNG UND GRIFFUMHÜLLUNG KPL.	INC. 43,44	LEVER, HEIGHT ADJUSTMENT CPL.	LEVIER, REGLAGE HAUTEUR CPL.	PALANCA, AJUSTE ALTURA CPL.
2	44	1	671 010 450		HEBEL, HÖHENVERSTELLUNG UND GRIFFUMHÜLLUNG KPL.	INC. 43,44	LEVER, HEIGHT ADJUSTMENT CPL.	LEVIER, REGLAGE HAUTEUR CPL.	PALANCA, AJUSTE ALTURA CPL.
2	45	2	671 002 030		SCHRAUBE	M6x14	TRIGGER BOLT	VIS	TORNILLO
2	46	6	671 006 064		6KT-SCHRAUBE	M8x6	HEXAGON HEAD BOLT	VIS À SIX PANS	TORNILLO HEXAGONAL
2	47	4	671 001 046		SCHRAUBE SELBSTSCHNEIDEND	8x19	SELF-TAPPING SCREW	VIS DE FORAGE	TORNILLO PERFORADOR
2	48	2	671 314 001		VERSCHLUSS	20"	COVER FIXING CAP	BOUCHON	TAPÓN
2	49	1	671 689 001		GETRIEBEABDECKUNG	20"	GEAR BOX PROTECTING COVER	REVÊTEMENT D' ENGRENAGES	CUBIERTA DE ENGRANAJES
2	50	2	671 002 020		SCHRAUBE	M6x16	TRIGGER BOLT	VIS	TORNILLO
2	51	1	671 002 233		DRUCKPLATTE		PRESSURE PLATE	PLAQUE DE PRESSION	PLACA DE PRÉSION
2	52	1	671 010 300		ACHSE		AXLE	AXE	EJE
2	53	1	671 011 135		FEDER	φ2.8	SPRING	RESSORT	MUELLE
2	54	1	671 003 003		SCHRUMPFSCHLAUCH	φ6mm	HEAT SHRINKABLE TUBE	TUBE FLEXIBLE THERMORÉTRACTABLE	TUBO TERMORRETRACTIL
2	55	1	671 497 001		MULCHABDECKUNG		SIDE DISCHARGE COVER	COUVERCLE	CUBIERTA
2	56	1	671 546 001		SCHUTZHAUBE SEITENAUSWURF	20"	PROTECTION COVER	CAPOT DE PROTECTION	CUBIERTA PROTECTORA
2	57	2	671 006 091		SCHRAUBE	M8X40	BOLT	VIS	TORNILLO
2	58	2	671 006 004		FLACHKOPFSCHRAUBE	M8x52	FLAT HEAD BOLT	VIS À TÊTE CYLINDRIQUE	TORNILLO DE CABEZA PLANA
2	59	2	671 177 001		KABELCLIPP		CABLE CLIP	CLIP DE CÂBLE	CLIP PARA CABLE
2	60	1	671 001 815		UNTERHOLM	20"	LOWER HANDLE	MANCHE INFÉRIEURE	MANGO INFERIOR
2	61	4	671 005 007		MUTTER	M8	NUT	ECROU	TUERCA
2	62	4	671 453 001		STERNGRIFF		STAR KNOB	MANETTE	MANIJA DE ESTRELLA
2	63	4	671 001 085		SCHEIBE		WASHER	RONDELLE	ARANDELA
2	64	1	671 012 160		BOWDENZUG (MOTORBREMSE)		CONTROL CABLE (MOTOR BRAKE)	CÂBLE BOWDEN (FREIN MOTEUR)	TRACCIÓN BOWDEN (FRENO MOTOR)
2	65	1	671 012 170		BOWDENZUG (RADANTRIEB)		CONTROL CABLE (WHEEL DRIVE)	CÂBLE BOWDEN (ENTRAÎNEMENT DE ROUE)	TRACCIÓN BOWDEN (TRACCIÓN DE RUEDA)
2	66	1	671 001 710		SEKTOR, HÖHENVERSTELLUNG	20"	SECTOR, HEIGHT ADJUSTMENT	SECTEUR REGLAGE HAUTEUR	SECTOR, AJUSTE ALTURA
2	67	1	671 001 814		HOLM, OBERTEIL	20"	HANDLE, UPPER PART	MANCHERON, PARTIE SUPERIEURE	MANILLAR, PARTE SUPERIOR
2	68	1	671 001 816		HEBEL, MOTORBREMSE		LEVER, MOTOR BRAKE	LEVIER FREIN MOTEUR	PALANCA, FRENO MOTOR
2	69	2	671 687 001		HANDGRIFF		CLAMP PLATE	POIGNÉE	MANGO
2	70	3	671 005 016		6KT-MUTTER	M6	HEX. LOCK NUT	ECROU	TUERCA
2	71	3	671 007 008		SCHEIBE	φ16xφ8x0,8	WASHER	RONDELLE	ARANDELA
2	72	1	671 001 647		HAKEN		CABLE HOOK	TENON	GANCHO
2	73	2	671 006 077		SCHRAUBE	M6x35	BOLT	VIS	TORNILLO
2	74	1	671 010 620		MOTORFERNBEDIENUNG INKL. BOWDENZUG		THROTTLE HANDLE ASS'Y	LEVIER / CABLE, ACCELERATEUR	PALANCA / CABLE, ACELERADOR
2	75	1	671 006 059		SCHRAUBE	M6x50	BOLT	VIS	TORNILLO
2	76	2	671 008 003		FEDERSCHEIBE	φ6,65	SPRING WASHER	RONDELLE A RESSORT	ARANDELA ELASTICO

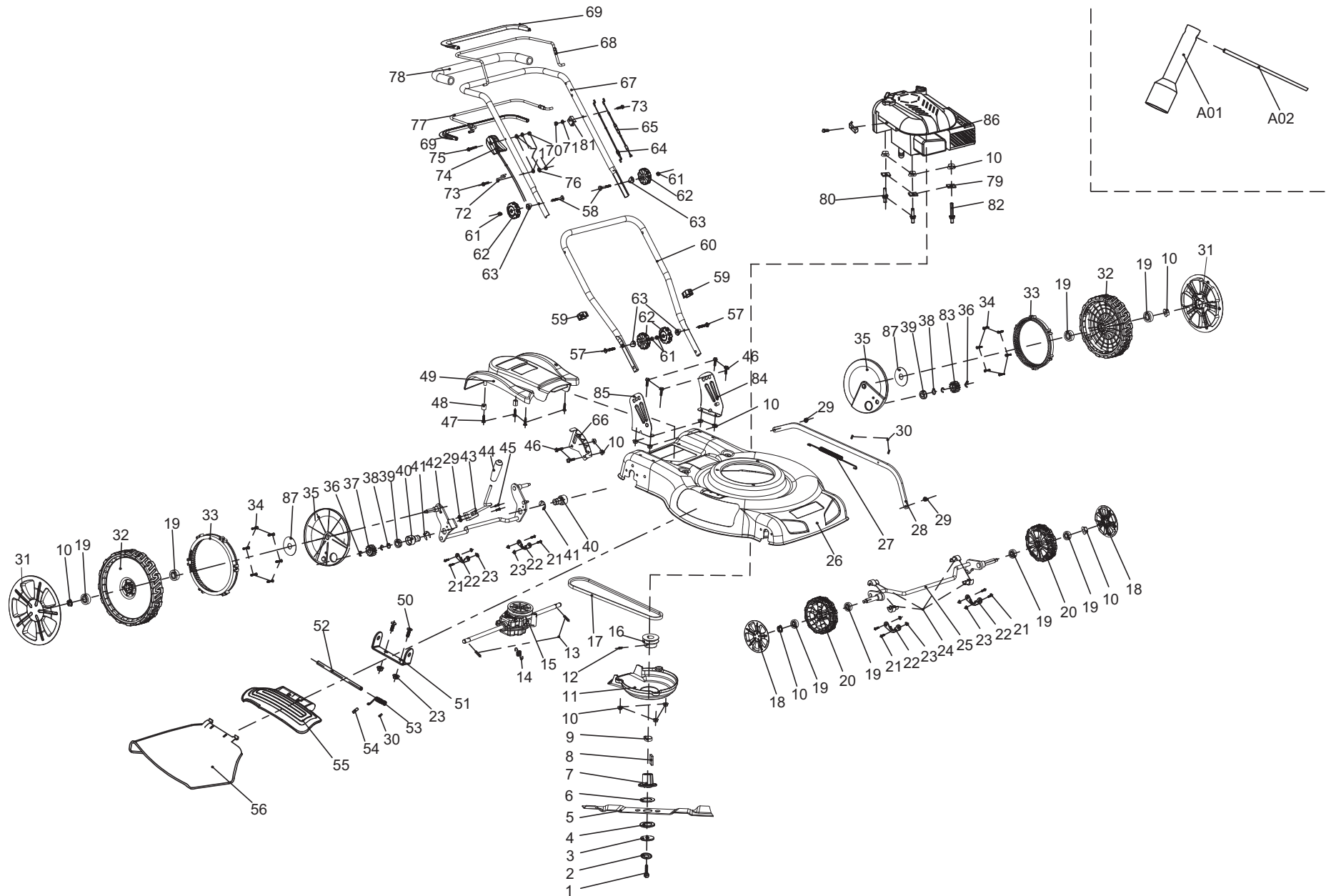

PM-5120, PM-5120 S

2

PM-5120 S  
PM-5120 S  
PM-5120 S  
PM-5120 S**DOLMAR**A member of the **Takita** Group

Seite / Page	Pos.	PM-5120 S	Teil-Nr. Part No. No. de pièce No. de pieza	Hinweise Notes Renseign. Nota	Bezeichnung	Spezifikation Specification	Description	Désignation	Denominación
2	77	1	671 001 817		HEBEL, ANTRIEB	20"	LEVER, DRIVING	LEVIER TRACTION	PALANCA, CONDUCCIÓN
2	78	1	671 101 901		GRIFFUMHÜLLUNG	φ22xφ32x580	HANDLE SHEATH	POIGNÉE	EMPUÑADURA
2	79	3	671 002 106		4KT-SCHEIBE	φ10	SQUARE GASKET	RONDELLE	ARANDELA
2	80	2	671 003 044		SPEZIALSCHRAUBE	M8x17x35	SPECIAL SCREW	VIS SPÉCIALE	TORNILLO ESPECIAL
2	81	1	671 336 001		HALTERUNG		FIXED BRACKET	FIXATION	SOPORTE
2	82	1	671 003 024		SPEZIALSCHRAUBE	M8x60x17	SPECIAL SCREW	VIS SPÉCIALE	TORNILLO ESPECIAL
2	83	1	671 003 001		ZAHNRAD, LINKS		GEAR WHEEL, LEFT	ROUE DENTEE, GAUCHE	PIÑON, IZQ.
2	84	1	671 001 599		GRIFFANBINDUNG, LINKS	20" DOLMAR red	BRACKET HANDLE, LEFT	BRIDE DE POIGNÉE, GAUCHE	FIJACIÓN DE MANGO, IZQ.
2	85	1	671 001 600		GRIFFANBINDUNG, RECHTS	20" DOLMAR red	BRACKET HANDLE, RIGHT	BRIDE DE POIGNÉE, DROITE	FIJACIÓN DE MANGO, DERECHA
2	86	1			MOTOR	675EX/190CC/2.7KW/300 0rpm,B&S,XRQ silver, DOLMAR	ENGINE	MOTEUR	MOTOR
2	87	2	671 007 065		SCHEIBE	Φ20	BIG WASHER	RONDELLE	ARANDELA
2	A01	1	671 001 078		STECKSCHLÜSSEL	21mm	BOX SPANNER	CLÉ À DOUILLE	LLAVE
2	A02	1	671 001 079		SPANNSTANGE	Φ8x110mm	SPANNER POLE	TIRANT	TENSOR

PM-5120, PM-5120 S

**DOLMAR**



A member of the **Takita** Group

	<b>Zeichenerklärung</b>	<b>Key to symbols</b>	<b>Légende</b>	<b>Explicación de símbolos</b>
<b>=&gt; 1999999</b> <b>2000000 =&gt;</b> <b>2003.04 =&gt;</b> <b>TI 2003/07</b> <b>Acc.</b> <b>=</b> <b>{</b> <b>m</b> <b>Corr.</b>	Produktion bis Serien-Nr. Neues Teil ab Serien-Nr. Neues Teil ab Jahr / Monat Siehe Technische Information Jahr / Nr. Zubehör (nicht im Lieferumfang) Keine Serienausführung, jedoch verwendbar Beinhaltet Positions-Nr. Meterware Druckfehlerberichtigung	Production to serial number New part from serial number New part from Year / Month See Technical Information Year / No. Accessories (not included in the delivery inventory) No standard execution, may be used Contains item number Sold by the meter Error correction	Production jusqu'à n° de série Nouvelle pièce à partir du n° de série Nouvelle pièce à partir de année / mois Voir information technique année / n° Accessoires (non compris dans la livraison) Aucune exécut. en série, cependant utilisable contient n° de numéro Au mètre Rectification d'erreurs	Producción hasta N° de serie Pieza nueva a partir de N° de serie Pieza nueva a partir de año / mes Véase inform. técnico año / N° Accesorios (no incluido en la extensión del suministro) No es de serie, pero sirve Contiene pos N° Por metro Fe de erratas
	Änderungen vorbehalten	Specifications subject to change without notice	Changements sans préavis	Mejoras constructivas sin previo aviso