

Spare Parts List
Ersatzteilliste
Liste de pièces détachées
Lista de piezas de repuesto

2013-07

MP-335.4 / Z

DOLMAR



A member of the *Makita* Group

MP-335.4 (D, GB, F, E)

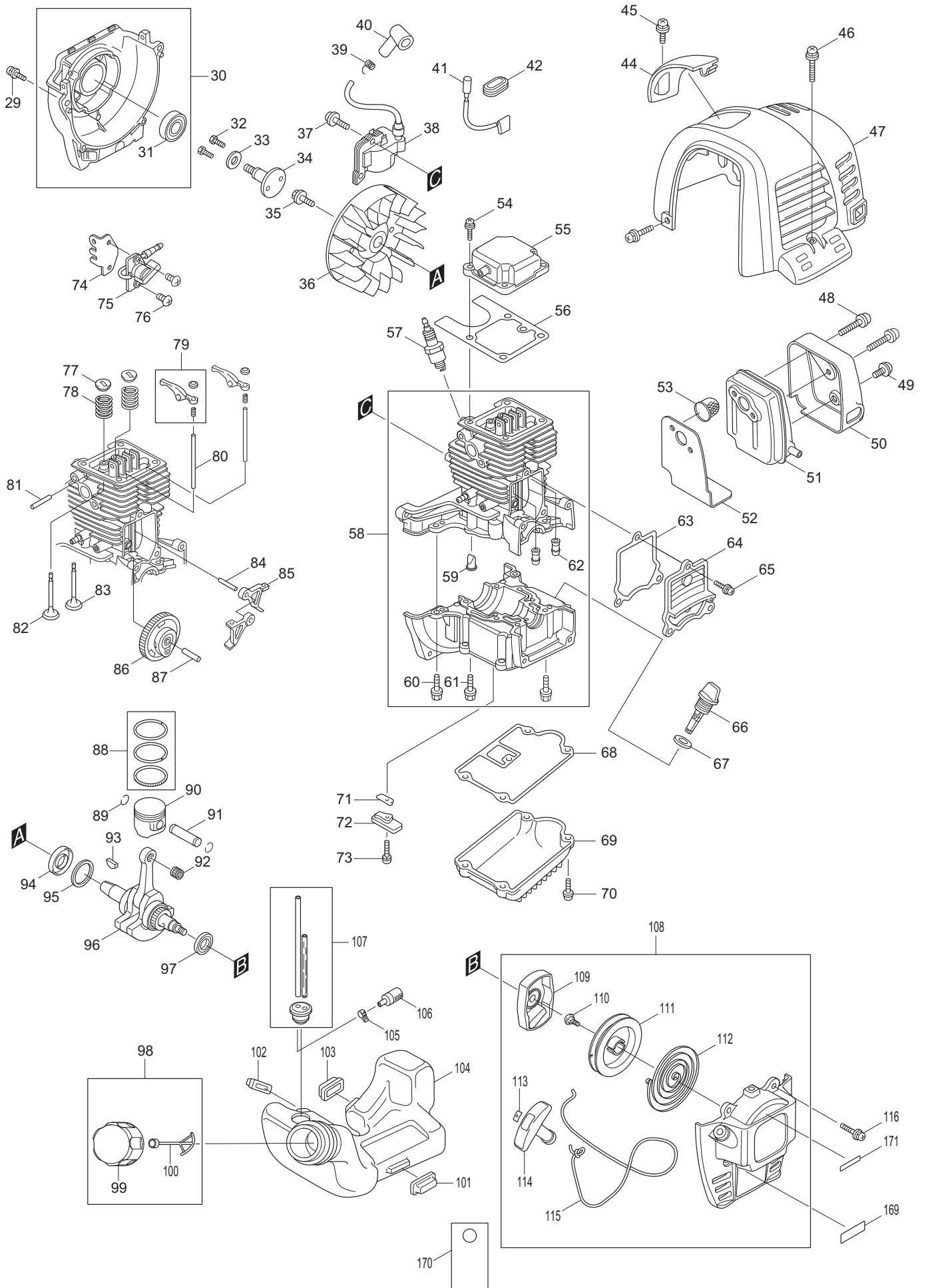

MP-335.4 / Z

1

Motor kpl.
Motor cpl.
Moteur cpl.
Motor cpl.

 A member of the *Makita* Group

Seite / Page	Pos.	MP-335.4 / Z	Teil-Nr. Part No. No. de pièce No. de pieza	Hinweise Notes Renseign. Nota	Bezeichnung	Spezifikation Specification	Description	Désignation	Denominación
1	29	4	367 922 223		SCHRAUBE	M5X16	H.S.H.BOLT WITH WR	VIS	TORNILLO
1	30	1	367 141 768		VENTILATORGEHÄU SE KPL.		BLOWER HOUSING COMPLETE	CARTER DE VENTILATEUR CPL.	CARCASA DEL VENTILADOR CPL.
1	31	1	367 211 243		KUGELLAGER	6002ZZ	BALL BEARING	ROULEMENT À BILLES	RODAMIENTO DE BOLAS
1	32	2	367 922 442		6KT-SCHRAUBE	M8X25	HEX. SOCKET HEAD BOLT	VIS HEXAGONAL	TORNILLO HEXAGONAL
1	33	1	367 016 997		ABDECKRING		WASHER	RONDELLE	ARANDELA
1	34	1	367 250 120		WELLE		SHAFT	ARBRE	EJE
1	35	1	367 265 577		SCHRAUBE	M6X16	HEX. HEAD BOLT	VIS HEXAGONAL	TORNILLO HEXAGONAL
1	36	1	367 700 601		POLRAD		FLYWHEEL	ROUE POLAIRE	VOLANTE ENCENDIDO
1	37	2	367 922 138		SCHRAUBE	M4X20	H.S.H.BOLT WITH WR	VIS	TORNILLO
1	38	1	367 168 501		ZÜNDSPULE		IGNITION COIL	BOBINE D' ALLUMAGE	BOBINA DE ENCENDIDO
1	39	1	367 324 891		STECKERKAPPENFE DER		PLUG CAP SPRING	RESSORT CAPUCHON DE FICHE	MUELLE TAPA DEL ENCHUFE
1	40	1	367 424 105		ZÜNDKERZENSTECK ER		SPARK PLUG CAP	FICHE DE BOUGIE	TAPA DE BUJÍA
1	41	1	367 638 665		KABEL		LEAD UNIT	CÂBLE	CABLE
1	42	1	367 424 313		KABELFÜHRUNG		GROMMET	GAIN CAOUTCHOUC	BOQUILLA DE GAUCHO
1	44	1	367 451 876		KERZENABDECKUNG		PLUG COVER	COUVERCLE P. BOUGIE	TAPA DE BUJIA
1	45	1	367 266 572		FLACHRUNDKOPFSC HRAUBE	M5X8	TRUSS HEAD SCREW	VIS	TORNILLO
1	46	3	367 911 213		FLACHKOPFSCHRAU BE	M5x12	PAN HEAD SCREW	VIS À TÊTE CYLINDRIQUE	TORNILLO DE CABEZA PLANA
1	47	1	367 451 884		ZYLINDERHAUBE	RED	CYLINDER COVER	CAPOT DE CYLINDRE	TAPA PARA CILINDRO
1	48	2	367 266 440		SCHRAUBE	M5X40	HEX. SOCKET HEAD BOLT	VIS HEXAGONAL	TORNILLO HEXAGONAL
1	49	1	367 265 184		SCHRAUBE	M5X5	+TRUSS HEAD SCREW	VIS	TORNILLO
1	50	1	367 345 915		VERBRENNUNGSSC HUTZ		MUFFLER COVER	PROTECTION DE COMBUSTION	PROTECCIÓN CONTRA COMBUSTIÓN
1	51	1	367 168 469		SCHALLDÄMPFER		EXHAUST MUFFLER	POT D' ÉCHAPPEMENT	SILENCIADOR
1	52	1	367 345 916		DICHTUNG SCHALLDÄMPFER		MUFFLER GASKET	JOINT DE POT D'ÉCHAPPEMENT	JUNTA DEL SILENCIADOR
1	53	1	367 324 980		FUNKENSCHUTZSIEB		SPARK ARRESTER SCREEN	TAMIS	TAMIZ
1	54	4	367 922 217		6KT-SCHRAUBE	M5x14	HEX. SOCKET HEAD BOLT	VIS HEXAGONAL	TORNILLO HEXAGONAL
1	55	1	367 140 419		ABDECKUNG F.KIPPHEBEL		ROCKER COVER COMPLETE	CAPOT POUR CULBUTEUR	TAPA DE BALANCINES CPL
1	56	1	367 162 307		DICHTUNG, ABDECKUNG F.KIPPHEBEL		ROCKER COVER GASKET	JOINT, CAPOT POUR CULBUTEUR	JUNTA, TAPA DE BALANCINES CPL
1	57	1	965 603 030		ZÜNDKERZE	NGK CMR6A	SPARK PLUG	BOUGIE	BUJÍA
1	58	1	367 135 563		ZYLINDERBLOCK-SA TZ		CYLINDER BLOCK ASSEMBLY	BLOC DE CYLINDRES	BLOQUE DE CILINDROS
1	59	2	367 424 201		RÜCKSCHLAGVENTI L		CHECK VALVE	SOUPAPE DE RETENU	VÁLVULA ANTIRRETORNO
1	60	4	367 922 222		SCHRAUBE	M5X16	HEX. SOCKET HEAD BOLT	VIS HEXAGONAL	TORNILLO HEXAGONAL
1	61	4	367 266 573		6KT-SCHRAUBE	M5X33	HEX. SOCKET HEAD BOLT	VIS HEXAGONAL	TORNILLO HEXAGONAL
1	62	2	367 424 200		DISTANZBUCHSE		SPACER	DOUILLE	CASQUILLO
1	63	1	367 162 274		DICHTUNG		CAM GEAR COVER GASKET	JOINT	JUNTA

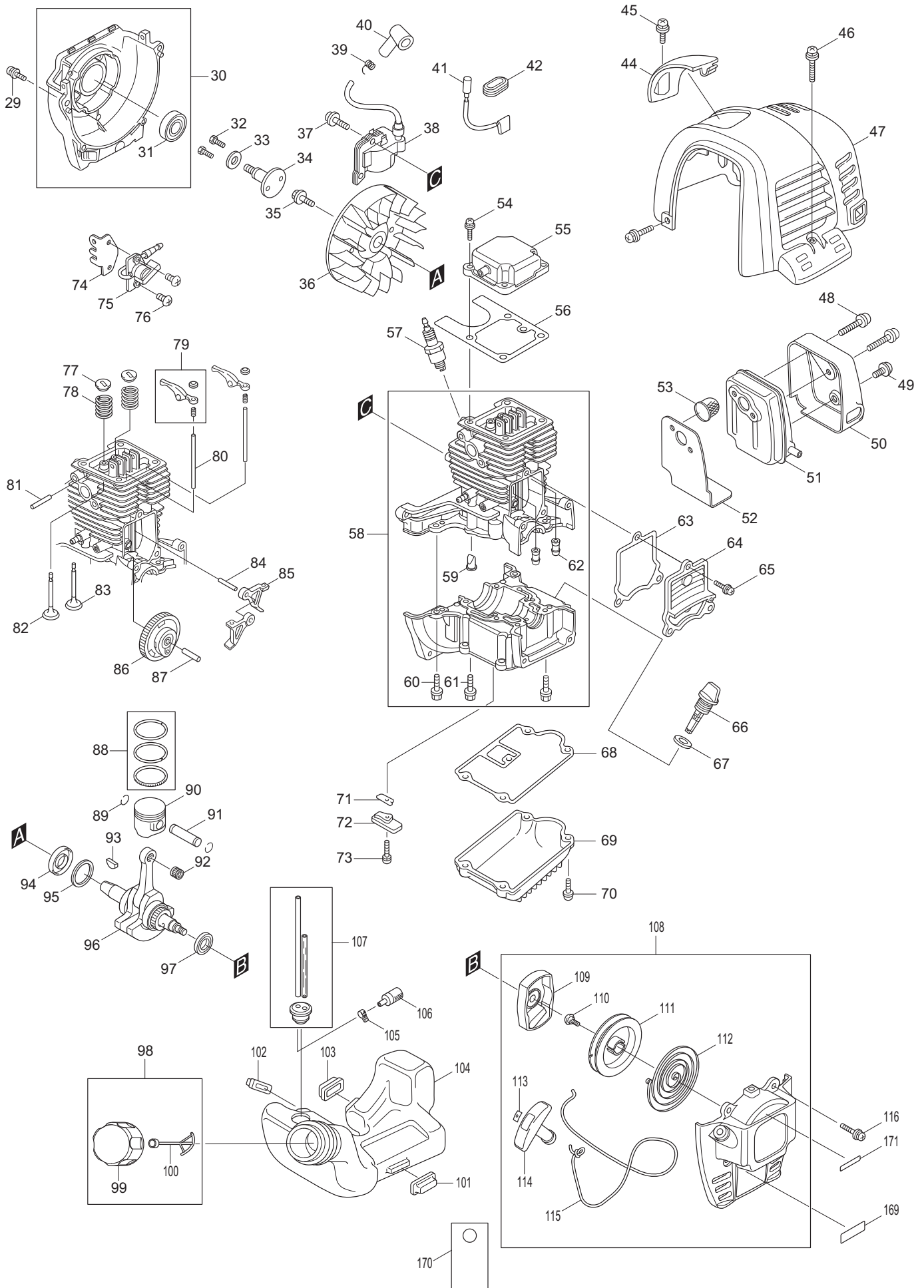

MP-335.4 / Z

1

Motor kpl.
Motor cpl.
Moteur cpl.
Motor cpl.

DOLMAR
 A member of the *Makita* Group

Seite / Page	Pos.	MP-335.4 / Z	Teil-Nr. Part No. No. de pièce No. de pieza	Hinweise Notes Renseign. Nota	Bezeichnung	Spezifikation Specification	Description	Désignation	Denominación
1	64	1	367 318 443		ABDECKUNG F.NOCKENRAD		CAMGEAR COVER	CAPOT	TAPA D. PIÑÓN D. ÁRB. DE LEV.
1	65	3	367 922 212		6KT-SCHRAUBE	M5X12	HEX. SOCKET HEAD BOLT	VIS HEXAGONAL	TORNILLO HEXAGONAL
1	66	1	367 450 565		ÖLPEILSTAB		OIL GAUGE	GAUGE D'HUILE	INDICADOR DEL NIVEL DE ACEITE
1	67	1	367 424 100		DICHTUNG		GASKET	JOINT	JUNTA
1	68	1	367 162 308		DICHTUNG		CASE GASKET	JOINT	JUNTA
1	69	1	367 318 612		ÖLWANNE		OIL CASE	CUVETTE A HUILE	CÁRTER DE ACEITE
1	70	4	367 922 217		6KT-SCHRAUBE	M5x14	HEX. SOCKET HEAD BOLT	VIS HEXAGONAL	TORNILLO HEXAGONAL
1	71	1	367 346 083		EINLASSMEMBRAN (REEDVALVE)		LEAD VALVE	MEMBRANE D'ADMISSION	VÁLVULA CON MEMBRANA DE ADMISIÓN
1	72	1	367 318 440		STOPPER F.REEDVALVE		RETAINER PLATE	FILTRE EN FEUTRE	FILTRO DE FIELTRO
1	73	1	367 922 112		6KT-SCHRAUBE	M4X10	HEX. SOCKET HEAD BOLT	VIS HEXAGONAL	TORNILLO HEXAGONAL
1	74	1	367 750 020		BLECH		PLATE	PLAQUE	PLACA
1	75	1	367 000 036		SCHALTER		SWITCH	INTERRUPTEUR	INTERRUPTOR
1	76	2	367 911 107		FLACHKOPFSCHRAU BE	M4X8	PAN HEAD SCREW	VIS À TÊTE CYLINDRIQUE	TORNILLO DE CABEZA PLANA
1	77	2	367 325 912		FEDERTELLER		SPRING RETAINER	CUVETTE DE RESSORT	CAJA DE RESORTE
1	78	2	367 234 181		DRUCKFEDER	11	COMPRESSION SPRING	RESSORT DE PRESSION	MUELLE DE COMPRESIÓN
1	79	2	367 125 554		KIPPHEBEL KPL.		ROCKER ARM ASS'Y	CULBUTEUR CPL.	GRUPO DEL BALANCÍN CPL.
1	80	2	367 256 866		STÖSSELSTANGE	2.5	ROD	TIGE-POUSSOIR	BARRA DE EMPUJADOR
1	81	1	367 256 200		STIFT	5	PIN	GOUPILLE	PASADOR
1	82	1	367 325 914		EINLASSVENTIL		INTAKE VALVE	VALVE D'ADMISSION	VÁLVULA DE ADMISIÓN
1	83	1	367 325 913		AUSLASSVENTIL		EXHAUST VALVE	SOUPAPE D'EMISSION	VÁLVULA DE ESCAPE
1	84	1	367 268 239		STIFT	4	PIN	GOUPILLE	PASADOR
1	85	2	367 313 169		NOCKENHEBEL		CAM LIFTER	LEVIER A CAMES	LEVAS
1	86	1	367 125 552		NOCKENRAD		CAM GEAR ASS'Y	PIGNON DE DISTRIBUTION	GRUPO DEL ÁRBOL DE LEVAS
1	87	1	367 268 238		STIFT	5	PIN	GOUPILLE	PASADOR
1	88	1	367 195 141		KOLBENRING SATZ		PISTON RING SET	JEU DE SEGMENTS DE PISTON	JUEGO DE SEGMENTOS DEL PISTÓN
1	89	2	367 233 983		SPRENGRING		CLIP	ANNEAU RESSORT	ANILLO ELÁSTICO
1	90	1	367 318 613		KOLBEN		PISTON	PISTON	PISTÓN
1	91	1	367 257 796		KOLBENBOLZEN		PISTON PIN	AXE DE PISTON	BULÓN DEL PISTÓN
1	92	1	367 250 130		NADELLAGER		NEEDLE ROLLER BEARING	CAGE A AIGULLES	JAULA DE AGUJAS
1	93	1	367 254 040		SCHEIBENFEDER	3	WOODRUFF KEY	CLAVETTE	CHAVETA
1	94	1	367 213 537		ÖLDICHTUNG	12	OIL SEAL	JOINT ÉTANCHE À L'HUILE	RETÉN DE ACEITE
1	95	1	367 267 425		FLACHSCHEIBE	26	FLAT WASHER	RONDELLE PLATE	ARANDELA
1	96	1	367 200 800		KURBELWELLE KPL.		CRANKSHAFT CPL.	VILEBREQUIN CPL.	CIGÜEÑAL CPL.
1	97	1	367 213 148		ÖLDICHTUNG	10	OIL SEAL	JOINT ÉTANCHE À L'HUILE	RETÉN DE ACEITE
1	98	1	367 125 472		KRAFTSTOFFTANKD ECKEL KPL.		FUEL TANK CAP ASSEMBLY	BOUCHON RESERV. CPL., CARB.	TORNILLO DE CIERRE CPL., COMB.
1	99	1	367 140 435		BENZINTANKDECKEL		FUEL TANK CAP	COUVERCLE	CIERRE DEPÓSITO
1	101	1	367 424 104		DÄMPFER		DAMPER	AMORTISSEUR	AMORTIGUADOR
1	102	1	367 424 102		DÄMPFER		DAMPER	AMORTISSEUR	AMORTIGUADOR
1	103	1	367 424 103		DÄMPFER		DAMPER	AMORTISSEUR	AMORTIGUADOR
1	104	1	367 451 877		KRAFTSTOFFTANK		FUEL TANK	RESERVOIR D'ESSENCE	DEPÓSITO DE COMBUSTIBLE
1	105	1	367 345 920		SCHLAUCHKLEMME		HOSE CLAMP	COLLIER	ABRAZADERA

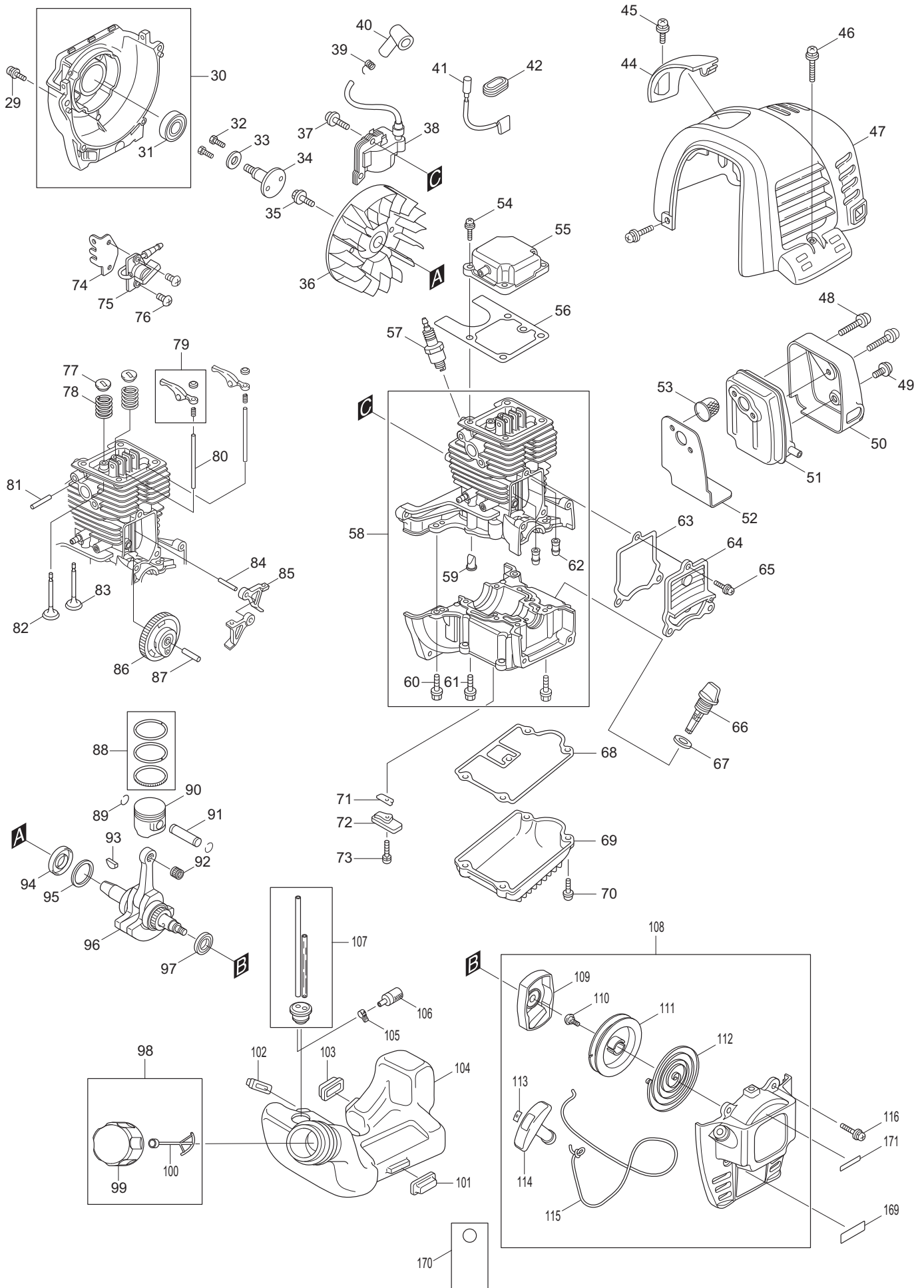

MP-335.4 / Z

1

Motor kpl.
Motor cpl.
Moteur cpl.
Motor cpl.
DOLMAR

 A member of the *Makita* Group

Seite / Page	Pos.	MP-335.4 / Z	Teil-Nr. Part No. No. de pièce No. de pieza	Hinweise Notes Renseign. Nota	Bezeichnung	Spezifikation Specification	Description	Désignation	Denominación
1	106	1	320 163 447		BENZINFILTER		FUEL FILTER	FILTRE D'ESSENCE	FILTRO DE GASOLINA
1	107	1	367 162 309		SCHLAUCH KPL.		TUBE	TUBE CPL.	TUBO CPL.
1	108	1	367 195 142		ANWERFVORRICHTUNG KPL.		RECOIL STARTER SET	DEPOSITE DE DEMARRAGE CPL.	DEPOSITO DE ARRANQUE CPL.
1	109	1	367 165 606		STARTERRAD		PULLEY	ROUE DÉMARREUR	RUEDA DE ARRANQUE
1	110	1	367 266 580		SCHNEIDSCHRAUBE	5X10	TAPPING SCREW	VIS TARAUDEUSE	TORNILLO DE ROSCA CORTANTE
1	111	1	367 451 923		SEILTROMMEL		REEL	TAMBOUR DE CÂBLE	TAMBOUR PARA CORDÓN
1	112	1	367 232 257		SPIRALFEDER		SPIRAL SPRING	RESSORT DE RAPPEL	RESORTE RETENCION
1	114	1	381 500 211		ANWERFGRIFF		STARTER KNOB	POIGNEE DE LANCEMENT	TIRADOR DE ARRANQUE
1	115	1	367 444 018		ANWERFSEIL		STARTER ROPE	CORDE DE LANCEUR	CUERDA DE ARRANQUE
1	116	1	221 233 160		SCHRAUBE KPL.	M5x14 W/W&SW	PAN HEAD SCREW	VIS CPL.	TORNILLO CPL.
1	169	1			ABGASAUFKLEBER		GAS EMISSION APPROVAL LABEL	PLAQUE, GAZ D'ÉCHAPPEMENT	CALCOMANIA, GAS DE ESCAPE
1	170	1	367 819 430		SICHERHEITSANHÄNGER	DE, FR	CAUTION TAG	PLAQUE	CALCOMANIA
1	171	1			SCHILD	SERIAL NO.	LABEL	PLAQUE	CALCOMANIA

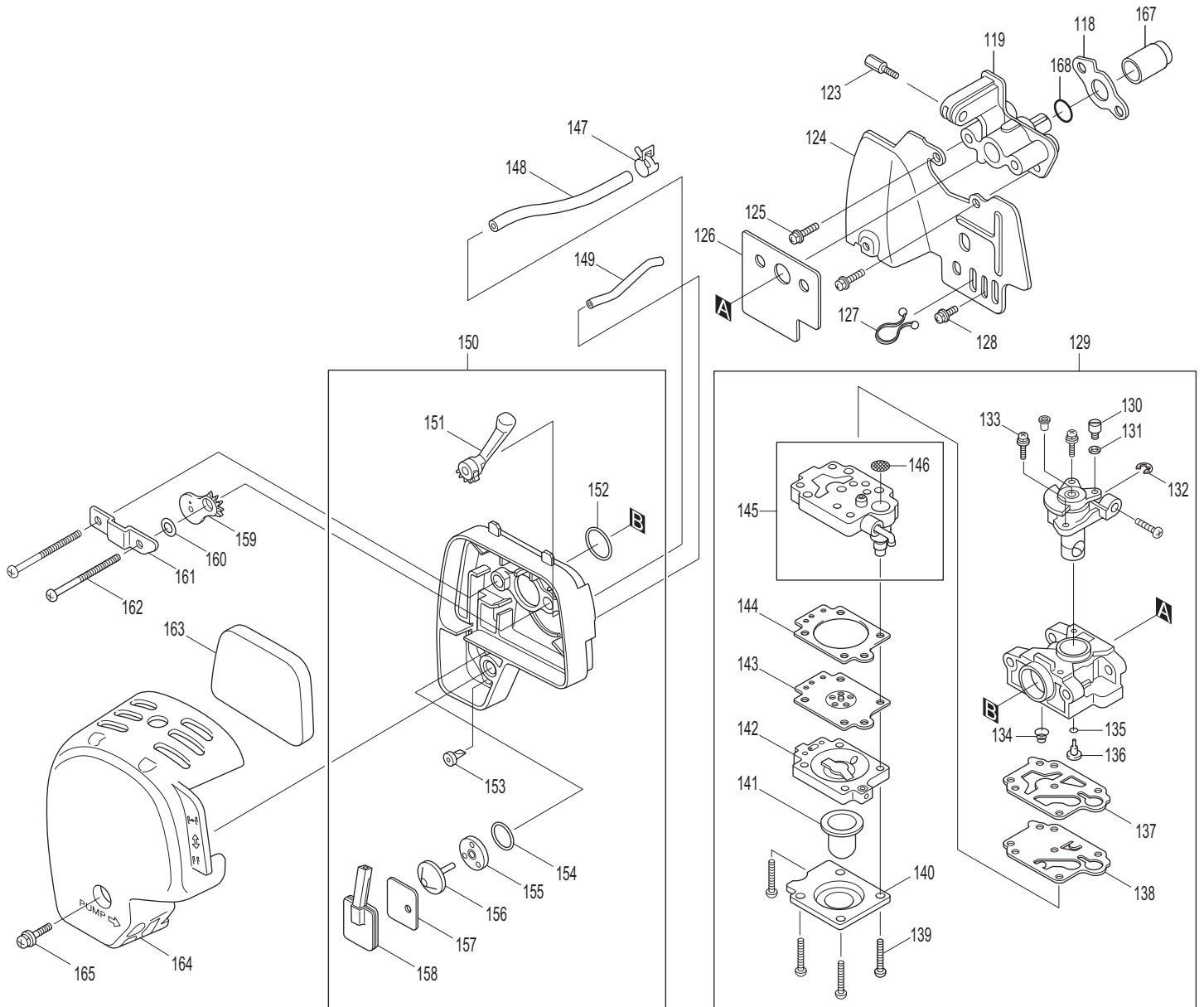

Seite / Page	Pos.	MP-335.4 / Z	Teil-Nr. Part No. No. de pièce No. de pieza	Hinweise Notes Renseign. Nota	Bezeichnung	Spezifikation Specification	Description	Désignation	Denominación
2	118	1	367 413 120		DICHTUNG F. ZWISCHENFLANSCH		INSULATOR GASKET	JOINT	JUNTA
2	119	1	367 451 874		ZWISCHENFLANSCH		INSULATOR	BRIDE INTERMEDIAIRE	BRIDA INTERMEDIA
2	123	1	367 325 934		STELLSCHRAUBE		ADJUST SCREW	VIS DE REGLAGE	TORNILLO DE AJUSTE
2	124	1	367 346 261		ABSCHIRMBLECH		CARBURETOR INSULATOR	TÔLE DE DERIVATION	CHAPA DE DISIPACIÓN
2	125	2	367 922 228		SCHRAUBE	5X18	H.S.H.BOLT WITH WR	VIS	TORNILLO
2	126	1	367 413 138		DICHTUNG		CARBURETOR GASKET	JOINT	JUNTA
2	127	1	367 450 562		KLAMMER		CLAMP	CRAMPON	GRAPA
2	128	1	367 922 213		SCHRAUBE	M5X12	H.S.H.BOLT WITH WR	VIS	TORNILLO
2	129	1	377 601 500		VERGASER		CARBURETOR	CARBURATEUR	CARBURADOR
2	130	1	367 325 922		NOCKEN		SWIVEL	CAME	LEVA
2	131	1	367 413 140		SCHEIBE		WASHER	RONDELLE	ARANDELA
2	132	1	367 257 964		SICHERUNGSRING	E-3	STOP RING	CIRCLIP	ANILLO SEGURIDAD
2	133	2	367 266 581		FLACHKOPFSCHRAU BE	M3X8	PAN HEAD SCREW	VIS À TÊTE CYLINDRIQUE	TORNILLO DE CABEZA PLANA
2	134	1	367 234 183		DRUCKFEDER	5-9	CONICAL COMPRESSION SPRING	RESSORT DE PRESSION	MUELLE DE COMPRESIÓN
2	135	1	367 213 538		O-RING	2	O RING	ANNEAU TORIQUE	ANILLO OBTURADOR
2	137	1	367 442 155		PUMPENDICHTUNG		PUMP GASKET	JOINT	JUNTA
2	138	1	367 168 575		PUMPENMEMBRANE		PUMP DIAPHRAGM	MEMBRANE DE POMPE	MEMBRANAS DE LA BOMBA
2	139	4	367 266 582		BLECHSCHRAUBE	3X24	TAPPING SCREW	VIS TARAUDEUSE	TORNILLO DE ROSCA CORTANTE
2	140	1	367 346 270		PRIMERDECKEL		PRIMER PUMP COVER	COUVERCLE DE POMPE PRIMER	TAPA DEL PRIMARIO
2	141	1	367 424 314		PRIMER PUMPE		PRIMER PUMP	POMPE PRIMER	BOMBA PRIMER
2	142	1	367 140 438		PUMPENABDECKUN G		AIR PURGE BODY ASS'Y	COUVERCLE	CUBIERTA
2	143	1	367 168 574		STEUERMENBRANE		METERING DIAPHRAGM	MEMBRANE DE COMMANDE	MEMBRANAS DE MANDO
2	144	1	367 442 154		DICHTUNG		METERING DIAPHRAGM GASKET	JOINT	JUNTA
2	146	1	367 352 010		SIEB		INLET SCREEN	TAMIS	TAMIZ
2	147	1	367 345 918		SCHLAUCHKLEMME		HOSE CLAMP	COLLIER	ABRAZADERA
2	148	1	367 422 055		ENTLÜFTUNGSSCHL AUCH	160mm	BREATHER PIPE	TUYAU DE PURGE	TUBO DE PURGA
2	149	1	367 422 042		ÖLRÜCKLAUFSCHLA UCH		PIPE	TUYAU DE RETOUR D'HUILE	TUBO DE RETORNO DEL ACEITE
2	150	1	367 125 468		LUFTFILTERBODEN KPL.		CLEANER PLATE ASS'Y	PLAQUE DE FILTRE A AIR CPL.	GRUPO DE LA PLANCHA DEL FILTRO
2	151	1	367 451 925		CHOKEHEBEL		CHOKE LEVER	LEVIER DE STARTER	PALANCA ESTRANGULADOR DE AIRE
2	152	1	367 213 540		O-RING	15	O RING	ANNEAU TORIQUE	ANILLO OBTURADOR
2	153	1	367 424 316		RÜCKSCHLAGVENTI L		CHECK VALVE	SOUPAPE DE RETENU	VÁLVULA ANTIRRETORNO
2	154	1	367 213 539		O-RING	14	O RING	ANNEAU TORIQUE	ANILLO OBTURADOR
2	155	1	367 451 924		VENTILSITZ		CHECK VALVE PLATE	SIEGE DE SOUPAPE	ASIENTO DE VÁLVULA
2	156	1	367 424 315		RÜCKSCHLAGVENTI L		CHECK VALVE	SOUPAPE DE RETENU	VÁLVULA ANTIRRETORNO
2	157	1	367 168 577		DICHTUNG		SEPARATOR GASKET	JOINT	JUNTA
2	158	1	367 168 576		ÖLSEPARATOR		SEPARATOR PLATE	SÉPARATEUR D'HUILE	SEPARADOR DEL ACEITE
2	159	1	367 450 560		CHOKEKLAPPE		CHOKE PLATE	CLAPET DE STARTER	TAPA DEL CHOKE
2	160	1	367 423 376		DICHTUNG		GASKET	JOINT	JUNTA

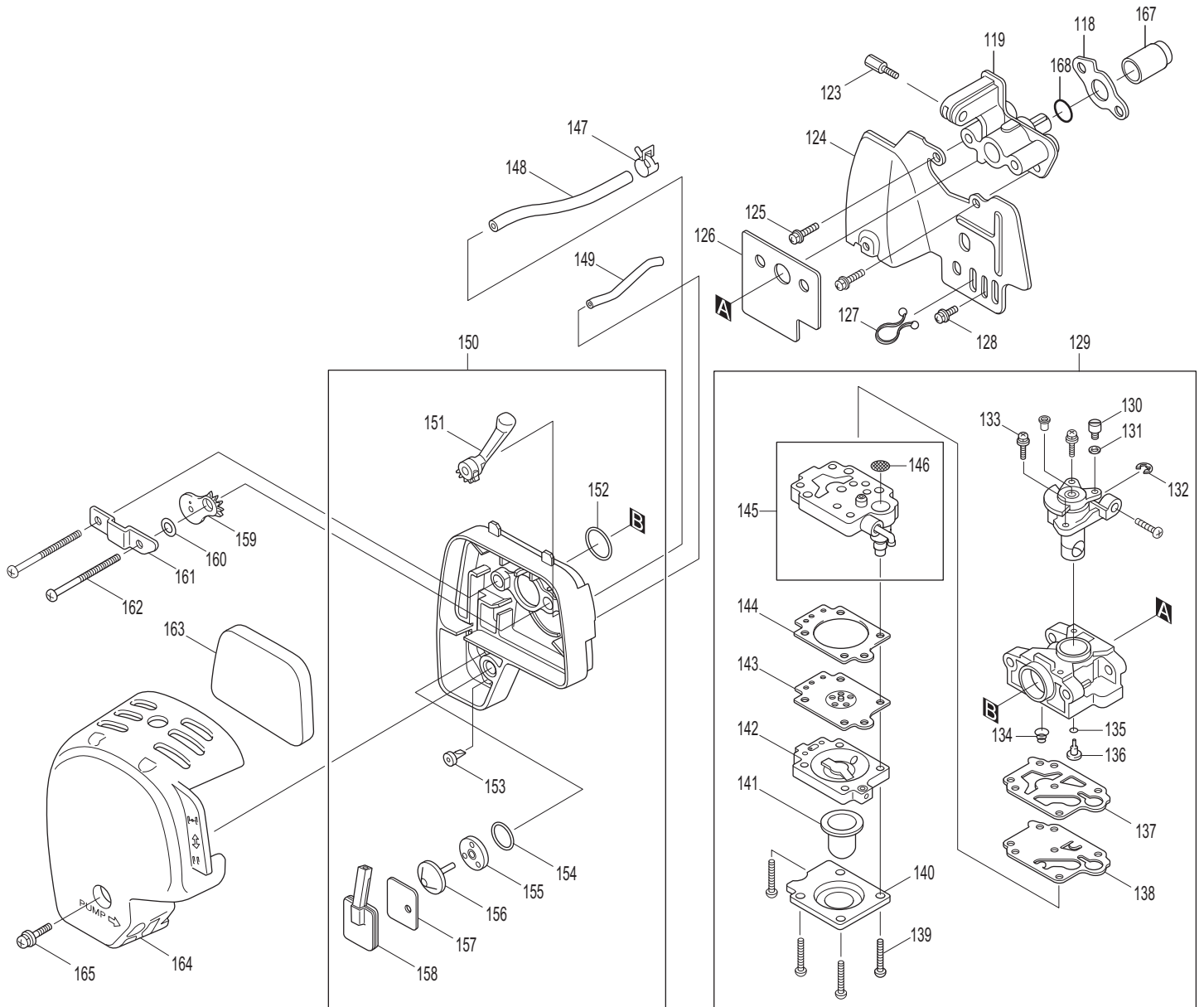

MP-335.4 / Z

2

Vergaser, Luftfilter
 Carburetor, air filter
 Carburateur, filtre à air
 Carburador, filtro de aire

DOLMAR

 A member of the *Takita* Group

Seite / Page	Pos.	MP-335.4 / Z	Teil-Nr. Part No. No. de pièce No. de pieza	Hinweise Notes Renseign. Nota	Bezeichnung	Spezifikation Specification	Description	Désignation	Denominación
2	161	1	367 345 919		SCHELLE		CLAMP	BRIDE DE FIXATION	ABRAZADERA
2	162	2	367 265 188		FLACHKOPFSCHRAUBE	M5X68	PAN HEAD SCREW	VIS À TÊTE CYLINDRIQUE	TORNILLO DE CABEZA PLANA
2	163	1	367 443 141		LUFTFILTER		ELEMENT AIR CLEANER	FILTRE À AIR	FILTRO DE AIRE
2	164	1	367 450 561		LUFTFILTERDECKEL		AIR CLEANER COVER	COUVERCLE DE FILTRE A AIR	CUBIERTA DEL FILTRO DE AIRE
2	165	4	221 233 160		SCHRAUBE KPL.	M5x14 W/W&SW	PAN HEAD SCREW	VIS CPL.	TORNILLO CPL.
2	167	1	367 325 915		ANSAUGROHR		INTAKE PIPE	TUYAU	TUBO
2	168	1	367 213 078		O-RING	10	O RING	ANNEAU TORIQUE	ANILLO OBTURADOR

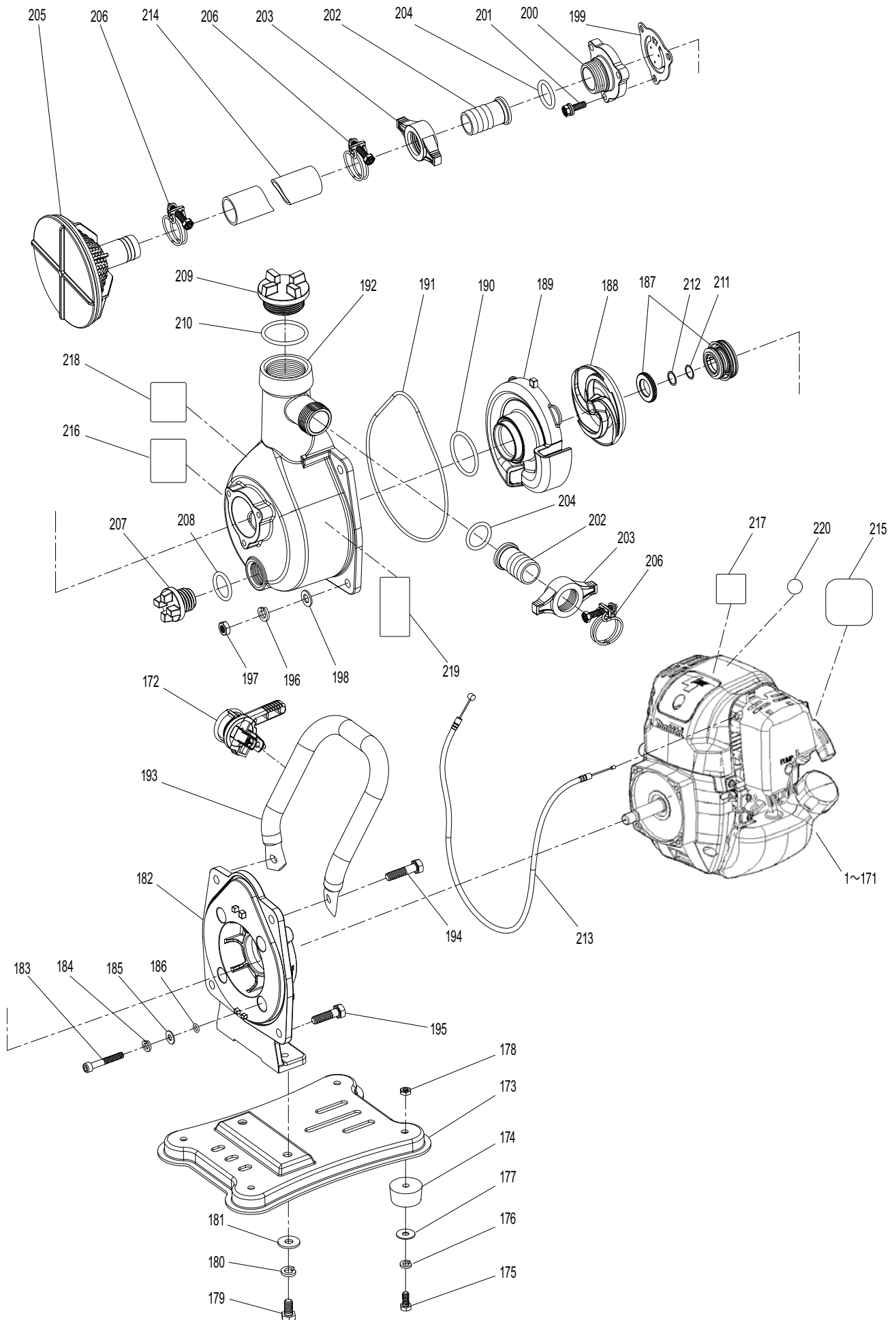

Seite / Page	Pos.	MP-335.4 / Z	Teil-Nr. Part No. No. de pièce No. de pieza	Hinweise Notes Renseign. Nota	Bezeichnung	Spezifikation Specification	Description	Désignation	Denominación
3	172	1	367 121 070		GASHEBEL		THROTTLE LEVER	LEVIER D' ACCÉLÉRATION	PALANCA DEL ACELERADOR
3	173	1	367 122 002		GRUNDPLATTE		BASE	PLAQUE DE TÔLE	PLANCHE DE CHAPA
3	174	4	367 122 003		GUMMIFUSS		RUBBER FOOT	PIED EN CAOUTCHOUC	PIE DE GOMA
3	175	4	367 122 004		6KT-SCHRAUBE		HEXAGON BOLT	VIS À SIX PANS	TORNILLO HEXAGONAL
3	176	4	367 122 005		FEDERING		SPRING RING	RONDELLE À RESSORT	ANILLO ELÁSTICO
3	177	4	367 122 006		DICHTUNG		GASKET	JOINT	JUNTA
3	178	4	367 122 007		6KT-MUTTER		HEXAGONAL NUT	ECROU HEXAGONAL	TUERCA HEXAGONAL
3	179	2	367 122 008		6KT-SCHRAUBE		HEXAGON BOLT	VIS À SIX PANS	TORNILLO HEXAGONAL
3	180	2	367 200 117		FEDERING		SPRING RING	RONDELLE À RESSORT	ANILLO ELÁSTICO
3	181	2	367 122 040		DICHTUNG		GASKET	JOINT	JUNTA
3	182	1	367 122 010		FLANSCH		FLANGE BRACKET	BRIDE	BRIDA
3	183	4	367 122 011		INNEN-6KT-SCHRAU BE		HEXAGON SOCKET SCREW	VIS INBUS	TORNILLO DE ALLAN
3	184	4	367 122 012		FEDERING		SPRING RING	RONDELLE À RESSORT	ANILLO ELÁSTICO
3	185	4	367 122 013		DICHTUNG		GASKET	JOINT	JUNTA
3	186	4	367 122 014		O-RING		O-RING	JOINT TORIQUE	ANILLO DE GUARNICIÓN
3	187	1	367 122 015		GLEITRINGDICHTUN G		MECHANICAL OIL SEAL	JOINT ÉTANCHE À L'HUILE	RETÉN DE ACEITE
3	188	1	367 122 016		LÜFTERRAD		IMPELLER	ROUE DE VENTILATEUR	RUEDA DE VENTILADOR
3	189	1	367 122 017		GEBLÄSEGEHÄUSE		VOLUTE CASE	CARTER DE VENTILATEUR	CARCASA DEL VENTILADOR
3	190	1	367 122 018		O-RING		O-RING	JOINT TORIQUE	ANILLO DE GUARNICIÓN
3	191	1	367 676 320		O-RING		O-RING	JOINT TORIQUE	ANILLO DE GUARNICIÓN
3	192	1	367 122 019		PUMPENGEHÄUSE		PUMP CASING	CARTER	CÁRTER
3	193	1	367 121 006		HANDGRIFF		HANDLE	POIGNÉE	MANGO
3	194	2	367 200 116		6KT-SCHRAUBE		HEXAGON BOLT	VIS À SIX PANS	TORNILLO HEXAGONAL
3	195	2	367 122 020		6KT-SCHRAUBE		HEXAGON BOLT	VIS À SIX PANS	TORNILLO HEXAGONAL
3	196	4	367 200 117		FEDERING		SPRING RING	RONDELLE À RESSORT	ANILLO ELÁSTICO
3	197	4	367 676 323		6KT-MUTTER		HEXAGONAL NUT	ECROU HEXAGONAL	TUERCA HEXAGONAL
3	198	4	367 200 091		DICHTUNG		FLAT GASKET	JOINT	JUNTA
3	199	1	367 121 007		RÜCKSCHLAGVENTI L		CHECK VALVE	SOUPAPE DE RETENU	VÁLVULA ANTIRRETORNO
3	200	1	367 121 008		SAUGFLANSCH		SUCTION FLANGE	BRIDE	BRIDA
3	201	3	367 200 011		6KT-SCHRAUBE		HEXAGON BOLT	VIS À SIX PANS	TORNILLO HEXAGONAL
3	202	2	367 676 327		SCHLAUCHNIPPEL	1"	HOSE JOINT	NIPPLE	NIPLE
3	203	2	367 121 009		SICHERUNGSMUTTE R		LOCKING NUT	ECROU AUTOBLOQUANT	TUERCA AUTOBLOCANTE
3	204	2	367 121 044		DICHTUNG	31 x 2,15 mm (NBR)	SEAL RING	JOINT	JUNTA
3	205	1	367 689 268		SIEBEINSATZ KPL.		STRAINER SCREEN CPL.	TAMIS CPL.	TAMIZ CPL.
3	206	3	367 676 330		SCHLAUCHSCHELLE SCHRAUBBAR	1"	SCREW HOSE CLAMP	COLLIER DE SERRAGE VISSABLE	ABRAZADERA ATORNILLABLE
3	207	1	367 676 331		VERSCHLUSSSCHRA UBE		THREADED PLUG	VIS DE FERMETURE	TAPÓN ROSCADO
3	208	1	367 676 329		O-RING		O-RING	JOINT TORIQUE	ANILLO DE GUARNICIÓN

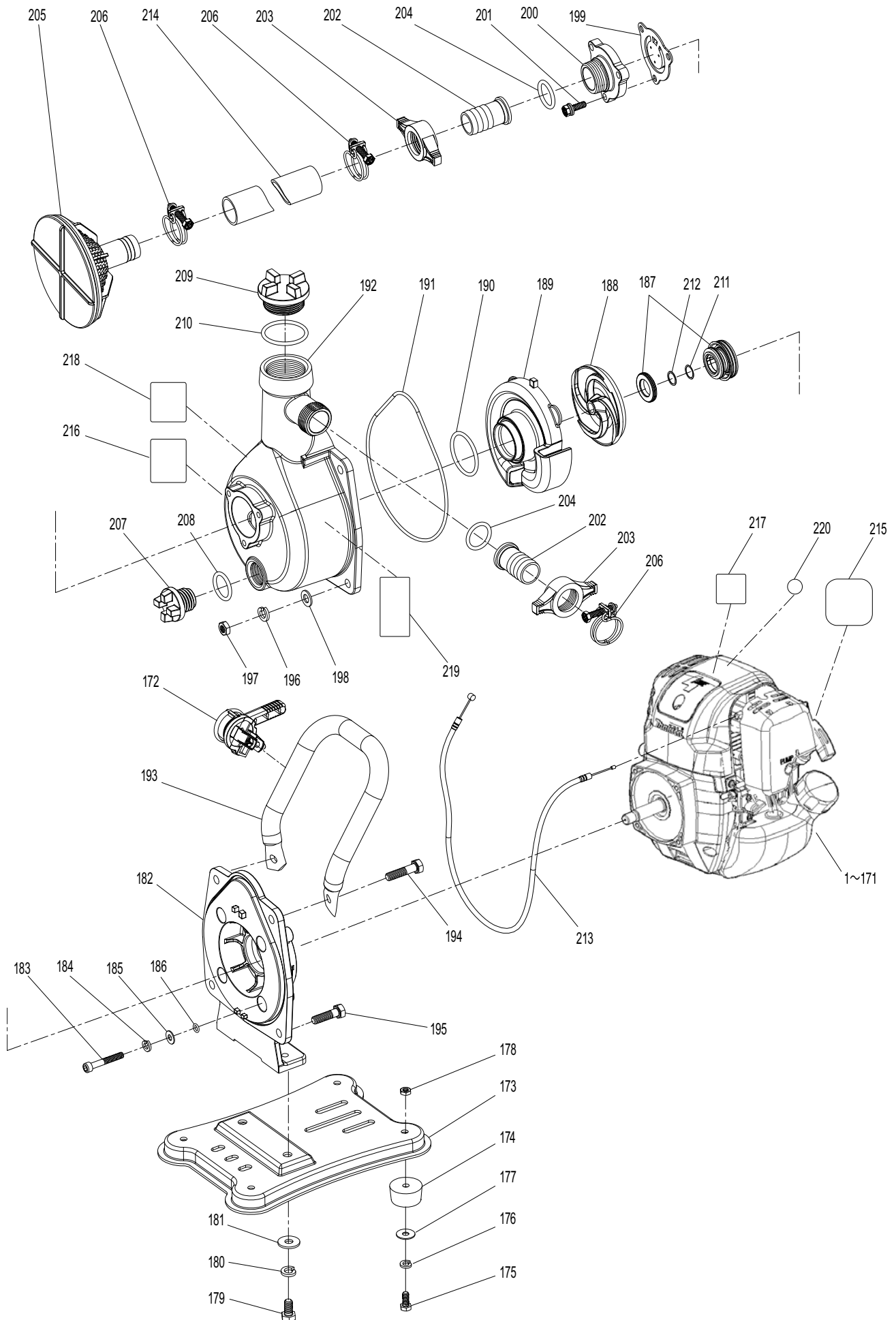

Seite / Page	Pos.	MP-335.4 / Z	Teil-Nr. Part No. No. de pièce No. de pieza	Hinweise Notes Renseign. Nota	Bezeichnung	Spezifikation Specification	Description	Désignation	Denominación
3	209	1	367 122 021		VERSCHLUSSSCHRAUBE		THREADED PLUG	VIS DE FERMETURE	TAPÓN ROSCADO
3	210	1	367 122 018		O-RING		O-RING	JOINT TORIQUE	ANILLO DE GUARNICIÓN
3	211	99	367 122 050		DICHTUNG		GASKET	JOINT	JUNTA
3	212	99	367 122 051		DICHTUNG		GASKET	JOINT	JUNTA
3	213	1	367 122 055		BOWDENZUG		BOWDEN CABLE	CÂBLE DE COMMANDE	TRANSMIS. FLEXIBLE BOWDEN
3	214	1	367 676 336		SAUGSCHLAUCH	1" x 3m	SUCTION PIPE	TUYAU FLEXIBLE	MANGUERA DE ASPIRACIÓN
3	215	1	367 121 013		HINWEISSCHILD		NOTE LABEL	PLAQUE	ETIQUETA DE INDICACIÓN
3	216	1	367 121 014		HINWEISSCHILD		NOTE LABEL	PLAQUE	ETIQUETA DE INDICACIÓN
3	217	1	367 121 030		HINWEISSCHILD		NOTE LABEL	PLAQUE	ETIQUETA DE INDICACIÓN
3	218	1	367 121 035		HINWEISSCHILD		NOTE LABEL	PLAQUE	ETIQUETA DE INDICACIÓN
3	219	1	367 333 192		HINWEISSCHILD		NOTE LABEL	PLAQUE	ETIQUETA DE INDICACIÓN

A09

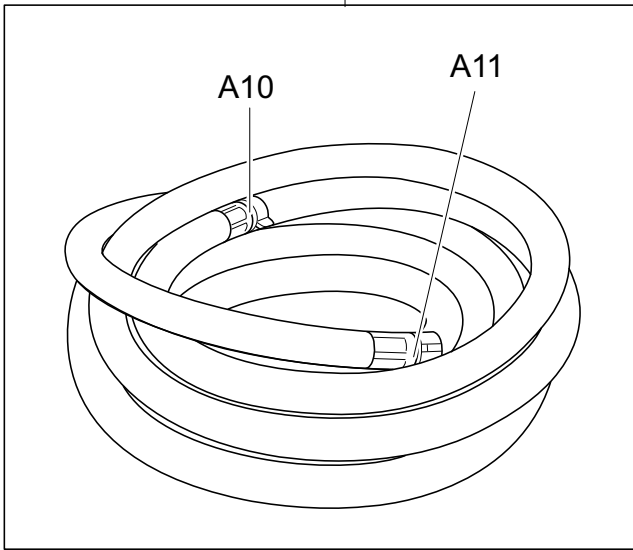

A12

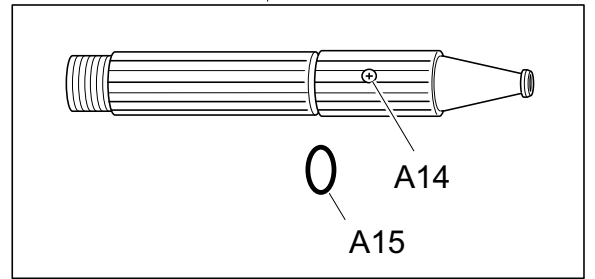

A18



A01

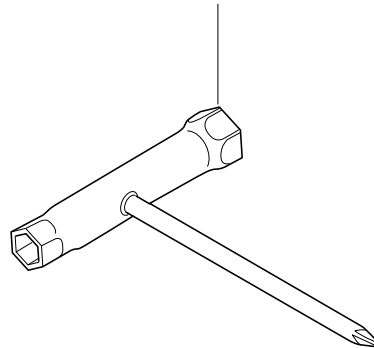

Seite / Page	Pos.	MP-335.4 / Z	Teil-Nr. Part No. No. de pièce No. de pieza	Hinweise Notes Renseign. Nota	Bezeichnung	Spezifikation Specification	Description	Désignation	Denominación
4	A01	1	367 121 017		STECKSCHLÜSSEL	SW 13/16	SOCKET WRENCH	CLÉ	LLAVE
4	A09	1	367 122 060		HOCHDRUCKSCHLAUCH KPL.	3/4" x 8m	HIGH PRESSURE HOSE CPL.	TUYAU HAUTE PRESSION CPL.	TUBO FLEXIBLE DE PRESIÓN CPL.
4	A10	1	367 121 044		DICHTUNG	31 x 2,15 mm (NBR)	SEAL RING	JOINT	JUNTA
4	A11	1	367 122 068		O-RING		O-RING	JOINT TORIQUE	ANILLO DE GUARNICIÓN
4	A12	1	367 122 030		SPRÜHHANDGRIFF		PISTOL	PISTOLET	PISTOLA
4	A14	1	367 122 034		KREUZSCHLITZSCHRAUBE		ROUND HEAD SCREW	VIS	TORNILLO
4	A15	1	367 122 035		O-RING		O-RING	JOINT TORIQUE	ANILLO DE GUARNICIÓN
4	A18	1	367 121 080		ÖLFLASCHE		OIL BOTTLE	BIDON	BOTELLA

- 1** Motor kpl.
Motor cpl.
Moteur cpl.
Motor cpl.
- 2** Vergaser, Luftfilter
Carburetor, air filter
Carburateur, filtre à air
Carburador, filtro de aire
- 3** Pumpe
Pump
Pompe
Bomba
- 4** Zubehör
Accessories
Accessoires
Accesorios

	Zeichenerklärung	Key to symbols
=> 1999999 2000000 => 2003.04 => TI 2003/07 Acc. = { m Corr.	Produktion bis Serien-Nr. Neues Teil ab Serien-Nr. Neues Teil ab Jahr / Monat Siehe Technische Information Jahr / Nr. Zubehör (nicht im Lieferumfang) Keine Serienausführung, jedoch verwendbar Beinhaltet Positions-Nr. Meterware Druckfehlerberichtigung	Production to serial number New part from serial number New part from Year / Month See Technical Information Year / No. Accessories (not included in the delivery inventory) No standard execution, may be used Contains item number Sold by the meter Error correction
	Änderungen vorbehalten	Specifications subject to change without notice
	Légende	Explicación de símbolos
=> 1999999 2000000 => 2003.04 => TI 2003/07 Acc. = { m Corr.	Production jusqu'à n° de série Nouvelle pièce à partir du n° de série Nouvelle pièce à partir de année / mois Voir information technique année / n° Accessoires (non compris dans la livraison) Aucune exécut. en série, cependant utilisable contient n° de numéro Au mètre Rectification d'erreurs	Producción hasta N° de serie Pieza nueva a partir de N° de serie Pieza nueva a partir de año / mes Véase inform. técnico año / N° Accesorios (no incluido en la extensión del suministro) No es de serie, pero sirve Contiene pos N° Por metro Fe de erratas
	Changements sans préavis	Mejoras constructivas sin previo aviso