

Spare Parts List
Ersatzteilliste
Liste de pièces détachées
Lista de piezas de repuesto

2013-04

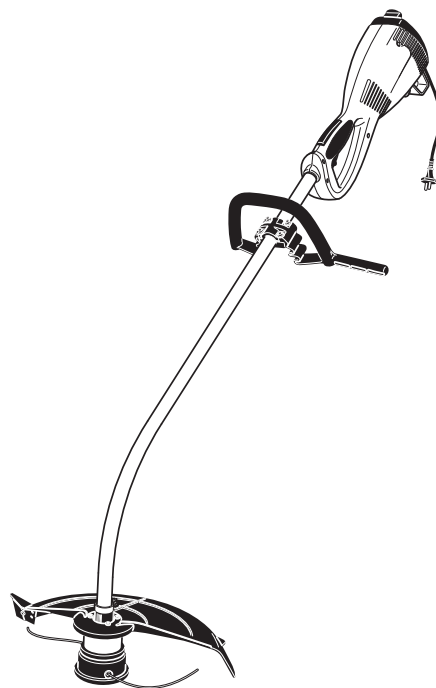

ET-70 C
ET-100 C
ET-100 C (RU)

DOLMAR



A member of the *Makita* Group

995700193 (D, GB, F, E)

ET-70 C, ET-100 C, ET-100 C
(RU)

1

Motor
Motor
Moteur
Motor

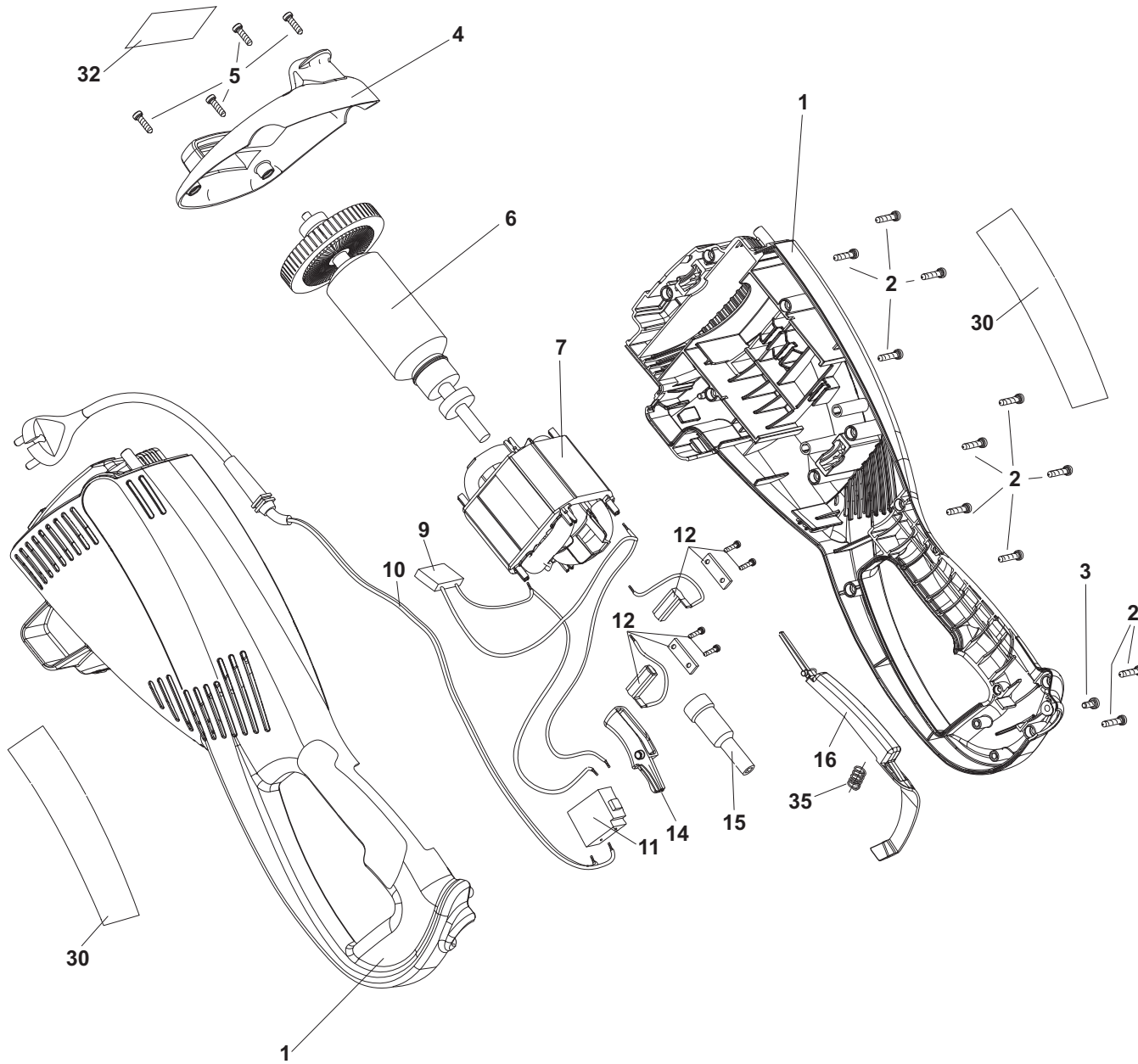

ET-70 C, ET-100 C, ET-100 C
(RU)

1

Motor
Motor
Moteur
Motor



Seite / Page	Pos.	ET-70 C	ET-100 C (RU)	Teil-Nr. Part No. No. de pièce No. de pieza	Hinweise Notes Renseign. Nota	Bezeichnung	Spezifikation Specification	Description	Désignation	Denominación
1	1	1	1	680 000 617		GEHÄUSE KPL.	Pipe ø 25,4 (=> 2010-02)	MOTOR CASE	CARTER MOTEUR	CÁRTER MOTOR
1	1	1	1	680 307 382		GEHÄUSE KPL.	Pipe ø 24 (2010-03 =>)	MOTOR CASE	CARTER MOTEUR	CÁRTER MOTOR
1	2	11	11	680 004 700		SCHRAUBE		SCREW	VIS	TORNILLO
1	3	1	1	680 013 400		SCHRAUBE		SCREW	VIS	TORNILLO
1	4	1	1	680 120 100		ABDECKHAUBE		BACK COVER	CAPOT PROTECTEUR	CUBIERTA PROTECTORA
1	5	4	4	680 053 500		SCHRAUBE		SCREW	VIS	TORNILLO
1	6	1		680 000 115		ROTOR KPL.		ROTOR ASSY.	ROTOR CPL.	ROTOR CPL.
1	6	1		680 000 116		ROTOR KPL.		ROTOR ASSY.	ROTOR CPL.	ROTOR CPL.
1	7	1		680 000 916		STATOR KPL.		STATOR ASSY.	STATOR CPL.	ESTATOR CPL.
1	7		1	680 000 912		STATOR KPL.		STATOR ASSY.	STATOR CPL.	ESTATOR CPL.
1	9	1	1	680 003 900		KONDENSATOR		CAPACITOR	CONDENSATEUR	CONDENSADOR
1	10	1	1	680 002 200		KABEL MIT STECKER	EU	CABLE WITH PLUG	CÂBLE AVEC PRISE	CABLE CON ENCHUFE
1	11	1	1	680 138 300		EIN/AUS SCHALTER		POWER SWITCH	INTERRUPTEUR	INTERRUPTOR
1	12	1	1	680 000 703		KOHLEBÜRSTE	2 PCS/SET	CARBON BRUSH	BALAIS DE CHARBON	ESCOBILLA DE CARBÓN
1	14	1	1	680 120 300		AUSLÖSER		TRIGGER	DÉCLIC	GATILLO
1	15	1	1	680 000 204		VERBINDUNGSSTÜCK		JOINT	RACCORD	RACOR
1	16	1	1	680 407 480		SICHERHEITSSPERRTASTE		CATCH LEVER	LEVIER DE VERROUILLAGE	PALANCA TRINCADA
1	30	2	2	680 119 600		SCHILD		LABEL	PLAQUE	CALCOMANIA
1	32	1		680 167 100		SCHILD		LABEL	PLAQUE	CALCOMANIA
1	32		1	680 143 500		SCHILD		LABEL	PLAQUE	CALCOMANIA
1	35	1	1	680 206 573		FEDER		SPRING	RESSORT	MUELLE

ET-70 C, ET-100 C, ET-100 C
(RU)

2

Motor
Motor
Moteur
Motor

DOLMAR
A member of the *Trakita* Group

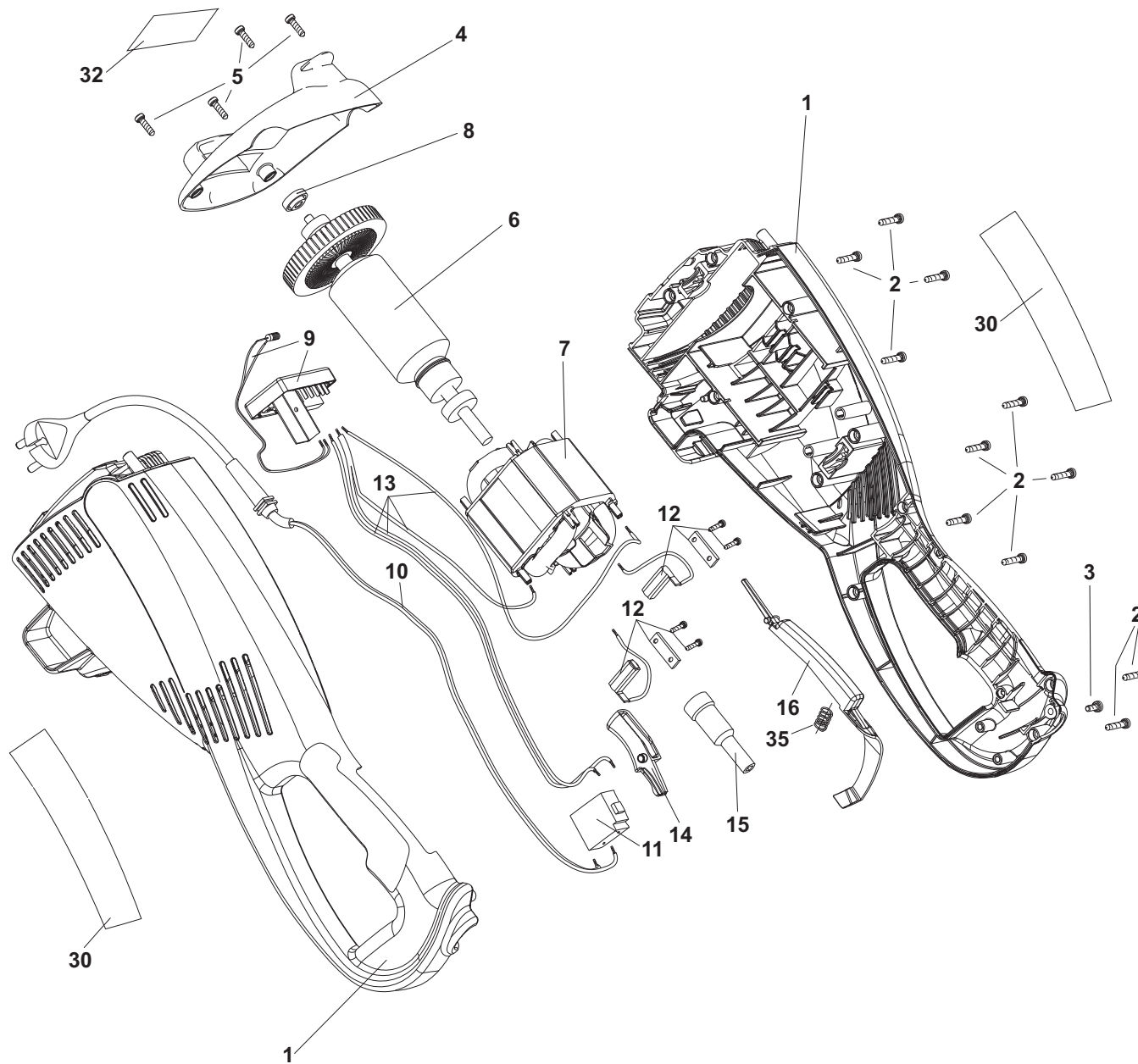

ET-70 C, ET-100 C, ET-100 C
(RU)

2

Motor
Motor
Moteur
Motor

DOLMAR
A member of the **Takita** Group

Seite / Page	Pos.	ET-100 C	Teil-Nr. Part No. No. de pièce No. de pieza	Hinweise Notes Renseign. Nota	Bezeichnung	Spezifikation Specification	Description	Désignation	Denominación
2	1	1	680 000 617		GEHÄUSE KPL.	Pipe ø 25,4 (=> 2010-02)	MOTOR CASE	CARTER MOTEUR	CÁRTER MOTOR
2	1	1	680 307 382		GEHÄUSE KPL.	Pipe ø 24 (2010-03 =>)	MOTOR CASE	CARTER MOTEUR	CÁRTER MOTOR
2	2	11	680 004 700		SCHRAUBE		SCREW	VIS	TORNILLO
2	3	1	680 013 400		SCHRAUBE		SCREW	VIS	TORNILLO
2	4	1	680 120 100		ABDECKHAUBE		BACK COVER	CAPOT PROTECTEUR	CUBIERTA PROTECTORA
2	5	4	680 053 500		SCHRAUBE		SCREW	VIS	TORNILLO
2	6	1	680 000 112		ROTOR KPL.		ROTOR ASSY.	ROTOR CPL.	ROTOR CPL.
2	7	1	680 000 912		STATOR KPL.		STATOR ASSY.	STATOR CPL.	ESTATOR CPL.
2	8	1	686 160 500		IMPULSGEBER		PULSE GENERATOR	GÉNÉRATEUR D'IMPULSIONS	GENERADOR DE IMPULSOS
2	9	1	680 008 020		ELEKTRONIKMODUL		ELECTRONIC MODULE	MODULE ÉLECTRONIQUE	ELECTRÓNICA
2	10	1	680 002 200		KABEL MIT STECKER	EU	CABLE WITH PLUG	CÂBLE AVEC PRISE	CABLE CON ENCHUFE
2	11	1	680 138 300		EIN/AUS SCHALTER		POWER SWITCH	INTERRUPTEUR	INTERRUPTOR
2	12	1	680 000 703		KOHLEBÜRSTE	2 PCS/SET	CARBON BRUSH	BALAI DE CHARBON	ESCOBILLA DE CARBÓN
2	13	1	680 000 405		KABELSATZ		SET OF WIRES	JEU DE CÂBLES	JUEGO DE CABLES
2	14	1	680 120 300		AUSLÖSER		TRIGGER	DÉCLIC	GATILLO
2	15	1	680 000 204		VERBINDUNGSSTÜCK		JOINT	RACCORD	RACOR
2	16	1	680 407 480		SICHERHEITSSPERRTASTE		CATCH LEVER	LEVIER DE VERROUILLAGE	PALANCA TRINCADA
2	30	2	680 119 600		SCHILD		LABEL	PLAQUE	CALCOMANIA
2	32	1	680 143 500		SCHILD		LABEL	PLAQUE	CALCOMANIA
2	35	1	680 206 573		FEDER		SPRING	RESSORT	MUELLE

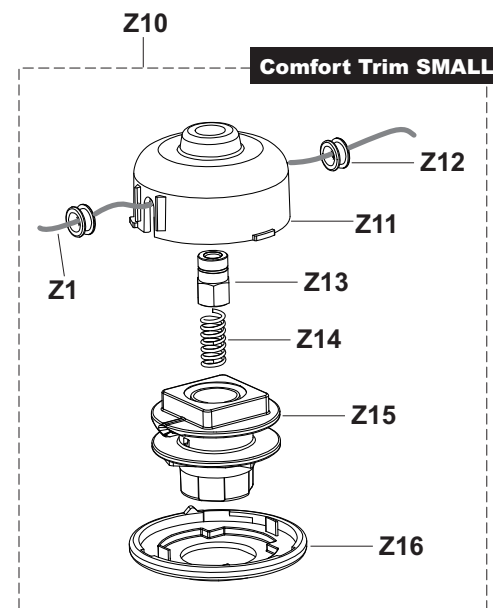
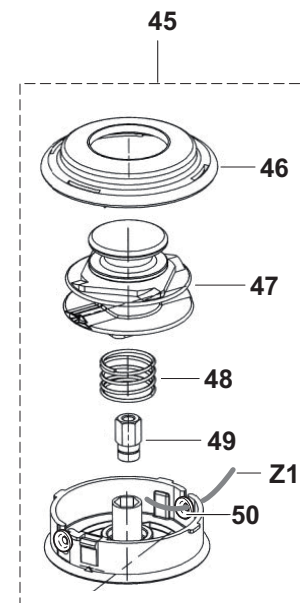
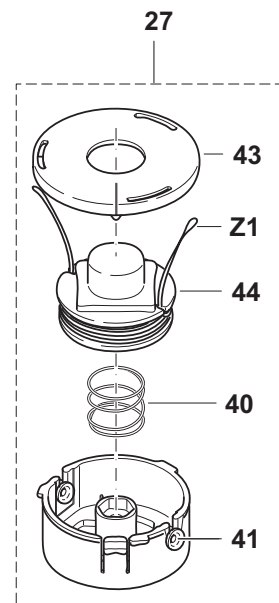
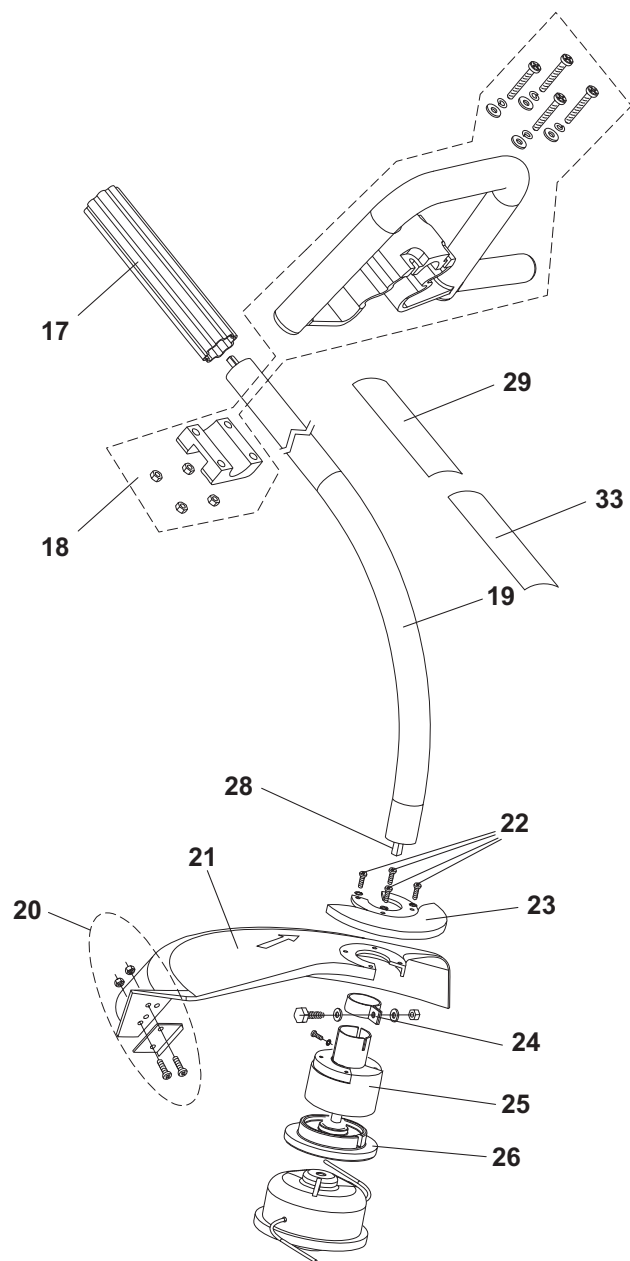

ET-70 C, ET-100 C, ET-100 C
(RU)

3

Schaftrohr, Schutzhaube
Main pipe, protection hood
Tube principal, capot de protection
Tubo principal, cubierta protectora**DOLMAR**
A member of the **Takita** Group

Seite / Page	Pos.	ET-70 C	ET-100 C	ET-100 C (RU)	Teil-Nr. Part No. No. de pièce No. de pieza	Hinweise Notes Renseign. Nota	Bezeichnung	Spezifikation Specification	Description	Désignation	Denominación
3	Z1	1	1	1	369 224 790		MÄHFADEN	ø 2,0 mm x 15 m (Round Trim) DOLMAR	NYLON LINE	FIL DE NYLON	HILO DE NILÓN
3	Z1	1	1	1	369 224 791		MÄHFADEN	ø 2,0 mm x 126 m (Round Trim) DOLMAR	NYLON LINE	FIL DE NYLON	HILO DE NILÓN
3	Z1	1	1	1	369 224 061		LÄRMARMER MÄHFADEN	ø 2,0 mm x 3,5 m DOLMAR	SILENT NYLON LINE	FIL DE NYLON SILENCIEUX	HILO DE NILÓN SILENCIOSO
3	Z1	1	1	1	369 224 060		LÄRMARMER MÄHFADEN	ø 2,0 mm x 15 m DOLMAR	SILENT NYLON LINE	FIL DE NYLON SILENCIEUX	HILO DE NILÓN SILENCIOSO
3	Z1	1	1	1	369 224 062		LÄRMARMER MÄHFADEN	ø 2,0 mm x 120 m DOLMAR	SILENT NYLON LINE	FIL DE NYLON SILENCIEUX	HILO DE NILÓN SILENCIOSO
3	Z10	1	1	1	680 224 200		FADENKOPF	COMFORT TRIM SMALL (DOLMAR)	NYLON CUTTING HEAD	TETE A 2 FILS	CABEZA 2 CORT
3	Z11	1	1	1	380 224 793		GEHÄUSE		HOUSING	CARTER	CÁRTER
3	Z12	2	2	2	369 224 010		FADENBUCHSE		THREAD BUSH	DOUILLE DE FIL	BUJE DE HILO
3	Z13	1	1	1	680 224 600		ADAPTER		ADAPTOR	ADAPTEUR	ADAPTADOR
3	Z14	1	1	1	378 224 793		FEDER		SPRING	RESSORT	MUELLE
3	Z15	1	1	1	380 224 796		SPULE		SPOOL	BOBINE	BOBINA
3	Z16	1	1	1	380 224 798		DECKEL		COVER	CAPOT	CUBIERTA
3	17	1	1	1	680 020 480		HANDGRIFF	Pipe ø 24 (2010-03 =>)	HANDLE	POIGNÉE	MANGO
3	17	1	1	1	680 120 400		HANDGRIFF	Pipe ø 25,4 (=> 2010-02)	HANDLE	POIGNÉE	MANGO
3	18	1	1	1	680 002 005		HANDGRIFF KPL.		HANDLE CPL.	POIGNÉE CPL.	MANGO CPL.
3	19	1	1	1	680 020 550		SCHAFTROHR GEBOGEN	Pipe ø 24 (2010-03 =>)	MAIN PIPE	TUBE PRINCIPAL	TUBO PRINCIPAL
3	19	1	1		680 001 026		SCHAFTROHR GEBOGEN	Pipe ø 25,4 (=> 2010-02)	MAIN PIPE	TUBE PRINCIPAL	TUBO PRINCIPAL
3	19			1	680 001 029		SCHAFTROHR GEBOGEN	Pipe ø 25,4 (=> 2010-02)	MAIN PIPE	TUBE PRINCIPAL	TUBO PRINCIPAL
3	20	1	1	1	680 005 204		FADENMESSER KPL.		LINE CUTTER CPL.	COUTEAU DE FIL CPL.	CUCHILLA DE HILOS CPL.
3	21	1	1	1	680 171 000		SCHUTZHAUBE	RED	PROTECTION HOOD	CAPOT DE PROTECTION	CUBIERTA PROTECTORA
3	22	4	4	4	680 122 700		SCHRAUBE		SCREW	VIS	TORNILLO
3	23	1	1	1	680 171 200		SCHUTZLEISTE		GUARD EXTENSION	BANDE DE PROTECTION	BANDA DE PROTECCIÓN
3	24	1	1	1	680 001 803		SPANNSCHELLE		CLAMPING RING	BRIDE DE SERRAGE	ABRAZADERA
3	25	1	1	1	680 020 490		LAGERGEHÄUSE	Pipe ø 24 (2010-03 =>)	GEAR HOUSING	CARTER DE ROULEMENT	CAJA DEL COJINETE
3	25	1	1	1	680 001 705		LAGERGEHÄUSE	Pipe ø 25,4 (=> 2010-02)	GEAR HOUSING	CARTER DE ROULEMENT	CAJA DEL COJINETE
3	26	1	1	1	680 119 900		WICKELSCHUTZ		WINDING PREVENTER	CAPOT DE PROTECTION	TAPA PROTECTORA
3	27	1	1	1	369 224 101		2-FADENKOPF	tap&go (ø2,0mm)	DUAL LINE TRIMMING HEAD	TÊTE À 2 FILS DE NYLON	CABEZAL DE 2 HILOS DE NILÓN
3	28	1		1	680 001 115		FLEXWELLE		TRANSMISSION SHAFT	ARBRE DE TRANSMISSION	ARBOL DE TRANSMISIÓN
3	28		1		680 001 116		FLEXWELLE		TRANSMISSION SHAFT	ARBRE DE TRANSMISSION	ARBOL DE TRANSMISIÓN
3	29	1	1	1	680 119 300		SCHILD		LABEL	PLAQUE	CALCOMANIA
3	33	1	1		680 144 000		SICHERHEITSAUFKLEBER		SAFETY LABEL	PLAQUE	CALCOMANIA
3	33			1	680 144 090		SICHERHEITSAUFKLEBER		SAFETY LABEL	PLAQUE	CALCOMANIA
3	40	1	1	1	378 224 030		FEDER		SPRING	RESSORT	MUELLE
3	41	2	2	2	369 224 010		FADENBUCHSE		THREAD BUSH	DOUILLE DE FIL	BUJE DE HILO
3	43	1	1	1	369 224 110		DECKEL		COVER	COUVERCLE	TAPA
3	44	1	1	1	369 224 120		SPULE		SPOOL	BOBINE	BOBINA
3	45	1	1	1	680 224 069		2-FADENKOPF	tap&go	DUAL LINE TRIMMING HEAD	TÊTE À 2 FILS DE NYLON	CABEZAL DE 2 HILOS DE NILÓN

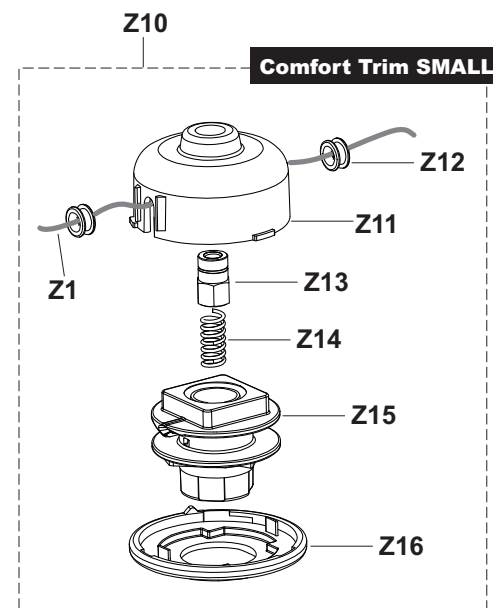
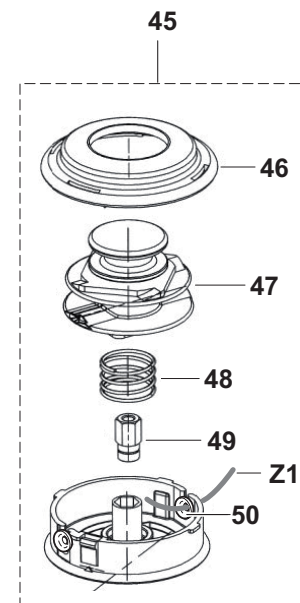
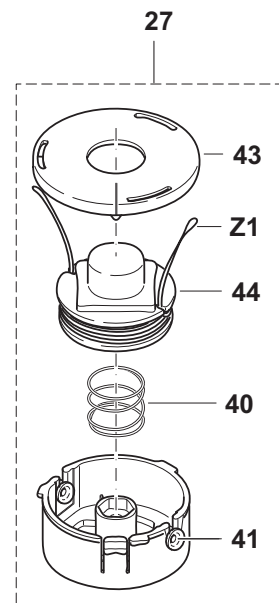
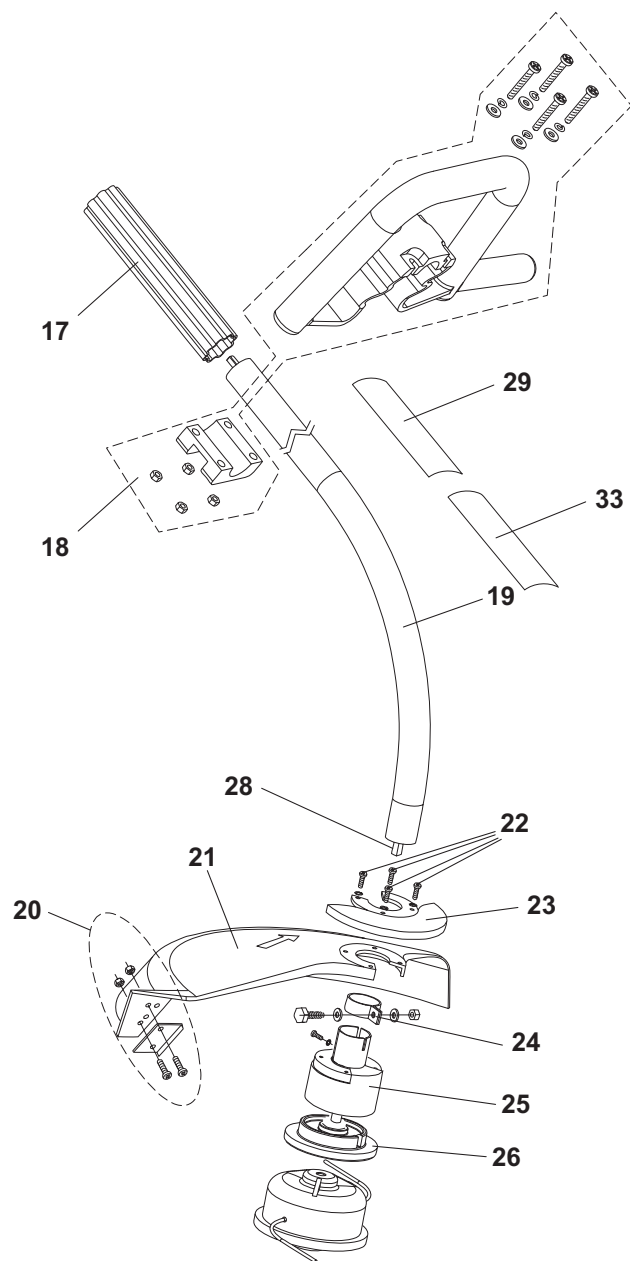

ET-70 C, ET-100 C, ET-100 C
(RU)

3

Schaftrohr, Schutzhaube
Main pipe, protection hood
Tube principal, capot de protection
Tubo principal, cubierta protectora

DOLMAR

A member of the **Makita** Group

Seite / Page	Pos.	ET-70 C	ET-100 C	ET-100 C (RU)	Teil-Nr. Part No. No. de pièce No. de pieza	Hinweise Notes Renseign. Nota	Bezeichnung	Spezifikation Specification	Description	Désignation	Denominación
3	46	1	1	1	680 224 698		DECKEL		COVER	COUVERCLE	TAPA
3	47	1	1	1	680 224 695		SPULE		SPOOL	BOBINE	BOBINA
3	48	1	1	1	378 224 030		FEDER		SPRING	RESSORT	MUELLE
3	49	1	1	1	680 224 600		ADAPTER		ADAPTOR	ADAPTEUR	ADAPTADOR
3	50	2	2	2	378 224 020		FADENBUCHSE		THREAD BUSH	DOUILLE DE FIL	BUJE DE HILO

ET-70 C, ET-100 C, ET-100 C
(RU)

	Zeichenerklärung	Key to symbols	Légende	Explicación de símbolos
=> 1999999 2000000 => 2003.04 => TI 2003/07 Acc. = { m Corr.	Produktion bis Serien-Nr. Neues Teil ab Serien-Nr. Neues Teil ab Jahr / Monat Siehe Technische Information Jahr / Nr. Zubehör (nicht im Lieferumfang) Keine Serienausführung, jedoch verwendbar Beinhaltet Positions-Nr. Meterware Druckfehlerberichtigung	Production to serial number New part from serial number New part from Year / Month See Technical Information Year / No. Accessories (not included in the delivery inventory) No standard execution, may be used Contains item number Sold by the meter Error correction	Production jusqu'à n° de série Nouveau pièce à partir du n° de série Nouveau pièce à partir de année / mois Voir information technique année / n° Accessoires (non compris dans la livraison) Aucune exécut. en série, cependant utilisable contient n° de numéro Au mètre Rectification d'erreurs	Producción hasta N° de serie Pieza nueva a partir de N° de serie Pieza nueva a partir de año / mes Véase inform. técnico año / N° Accesorios (no incluido en la extensión del suministro) No es de serie, pero sirve Contiene pos N° Por metro Fe de erratas
	Änderungen vorbehalten	Specifications subject to change without notice	Changements sans préavis	Mejoras constructivas sin previo aviso