

Spare Parts List
Ersatzteilliste
Liste de pièces détachées
Lista de piezas de repuesto

2013-03

EM-461

DOLMAR



A member of the *Makita* Group

EM-461 (D, GB, F, E)

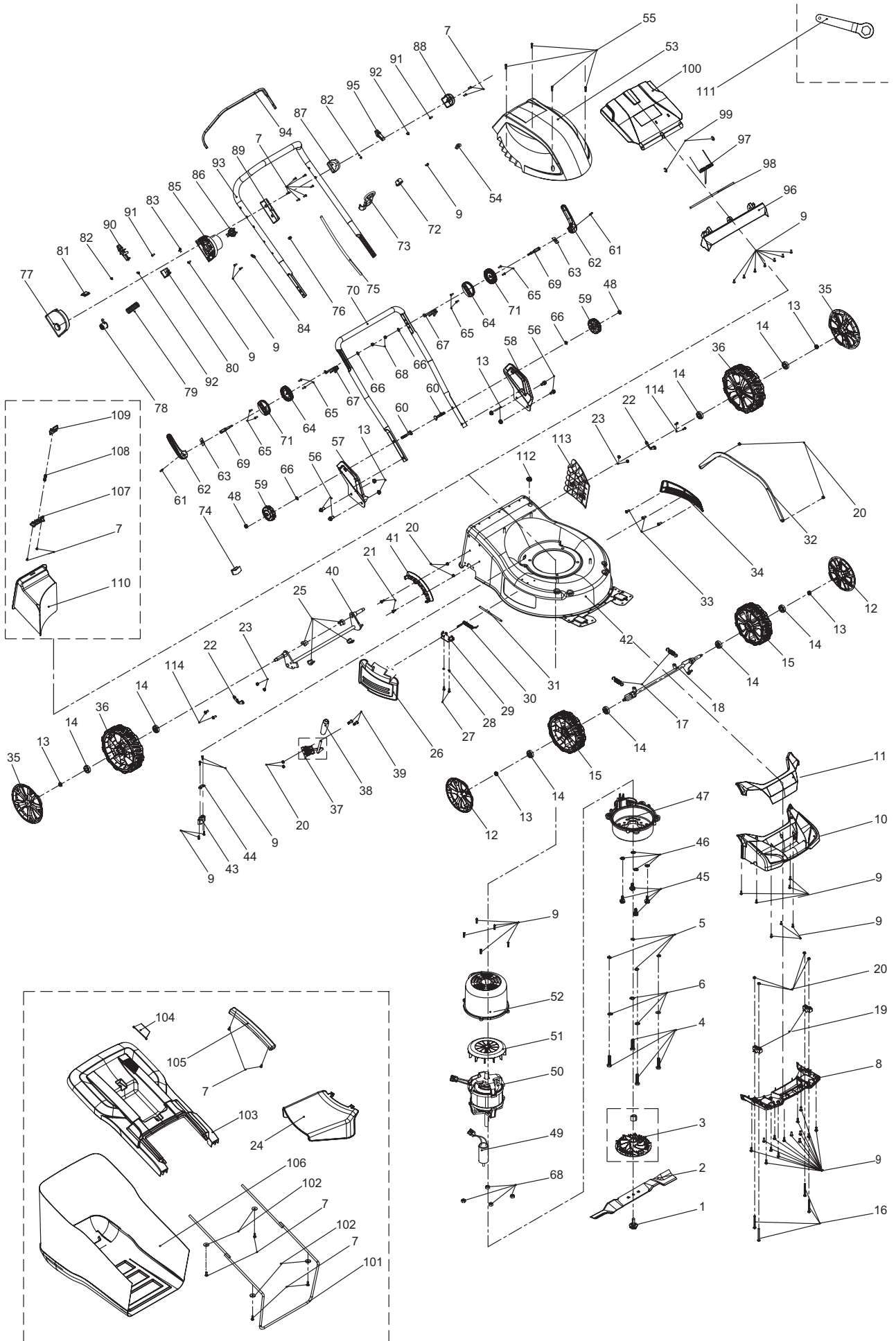

EM-461

1

EM-461, ELM4612
EM-461, ELM4612
EM-461, ELM4612
EM-461, ELM4612



 A member of the Makita Group

Seite / Page	Pos.	EM-461	Teil-Nr. Part No. No. de pièce No. de pieza	Hinweise Notes Renseign. Nota	Bezeichnung	Spezifikation Specification	Description	Désignation	Denominación
1	1	1	671 100 802		MESSERSCHRAUBE	M10*1.35*40	BLADE TIGHTEN BOLT	VIS DE LAME	TORNILLO DE LA CUCHILLA
1	2	1	671 146 102		MESSER	460X55X3mm	BLADE	LAME	CUCHILLA
1	3	1	671 005 057		MESSERHALTER		HUB	MOYEU	SOPORTE DE LA CUCHILLA
1	4	4	671 006 025		6KT-SCHRAUBE	M8x35	HEXAGON BOLT	VIS À SIX PANS	TORNILLO HEXAGONAL
1	5	4	671 008 002		FEDERRING	φ8,65	SPRING RING	RONDELLE À RESSORT	ANILLO ELÁSTICO
1	6	4	671 007 007		SCHEIBE	φ8	WASHER	RONDELLE	ARANDELA
1	7	16	671 001 005		SCHRAUBE SELBSTSCHNEIDEN D	4x16	SELF-TAPPING SCREW	VIS DE FORAGE	TORNILLO PERFORADOR
1	8	1	671 927 001		FRONTTEILTRÄGER		FRONT COVER SUPPORT	SUPPORT	SOPORTE
1	9	41	671 001 003		SCHRAUBE SELBSTSCHNEIDEN D	4x12	SELF-TAPPING SCREW	VIS DE FORAGE	TORNILLO PERFORADOR
1	10	1	671 926 001		FRONTTEIL		FRONT COVER	PANNEAU	FRONTAL CUBIERTA
1	11	1	671 925 001		FRONTTEILABDECKUNG		FRONT COVER BOARD	COUVERCLE	CUBIERTA
1	12	2	671 003 014		RADKAPPE	7"	WHEEL COVER	CHAPEAU DE MOYEU	CAPERUZA DE RUEDA
1	13	8	671 005 028		6KT-MUTTER	M8	HEXAGONAL LOCKING NUT	ECROU HEXAGONAL	TUERCA HEXAGONAL
1	14	8	671 004 012		KUGELLAGER	6201Z	BALL BEARING	ROULEMENT À BILLES	RODAMIENTO DE BOLAS
1	15	2	671 002 012		RAD	7"	WHEEL ASSY.	ROUE	RUEDA
1	16	4	671 006 119		SCHRAUBE	M6x60mm	BOLT	VIS	TORNILLO
1	17	2	671 011 230		FEDER		SPRING OF FRONT WHEEL AXLE	RESSORT	MUELLE
1	18	1	671 002 362		VORDERACHSE KPL.	333mm	FRONT WHEEL AXLE ASS'Y	ESSIEU AVANT CPL.	EJE DELANTERO CPL.
1	19	2	671 445 001		LAGERSCHALE		AXLE SHEATH	PLAQUETTE	COJINETE
1	20	10	671 005 005		6KT-MUTTER	M6	LOCKING NUT	ECROU	TUERCA
1	21	2	671 002 020		SCHRAUBE	M6x16	TRIGGER BOLT	VIS	TORNILLO
1	22	2	671 001 244		FIXIERUNG		RING OF AXLE FIXING	FIXATION	FIJACIÓN
1	23	4	671 005 024		6KT-MUTTER	M6	HEXAGONAL LOCKING NUT	ECROU HEXAGONAL	TUERCA HEXAGONAL
1	24	1	671 930 001		SCHUTZHAUBE SEITENAUSWURF		SIDE DISCHARGE PROTECTING COVER	CAPOT DE PROTECTION	CUBIERTA PROTECTORA
1	25	4	671 340 002		LAGERSCHALE		AXLE SHEATH	PLAQUETTE	COJINETE
1	26	1	671 929 001		MULCHABDECKUNG		SIDE DISCHARGE COVER BOARD	COUVERCLE	CUBIERTA
1	27	2	671 002 010		SCHRAUBE	M5x12	TRIGGER BOLT	VIS	TORNILLO
1	28	2	671 080 040		FEDERSCHEIBE		SPRING WASHER	RONDELLE A RESSORT	ARANDELA ELASTICO
1	29	1	671 001 571		FIXIERBLECH		FIXED PLATE	FIXATION	FIJACIÓN
1	30	1	671 011 205		FEDER		SPRING OF SIDE DISCHARGE COVER BOARD	RESSORT	RESORTE
1	31	1	671 001 019		ACHSE		AXLE	AXE	EJE
1	32	1	671 002 364		VERBINDUNGSSTANGE		LINK ROD	BARRE DE RACCORDEMENT	BARRA DE CONEXIÓN
1	33	3	671 010 310		SCHRAUBE SELBSTSCHNEIDEN D	4.2*8	SELF-TAPPING SCREW	VIS DE FORAGE	TORNILLO PERFORADOR
1	34	1	671 928 001		SCHUTZABDECKUNG		PROTECTING HOOD	CAPOT PROTECTEUR	CUBIERTA PROTECTORA
1	35	2	671 030 150		RADKAPPE	8"	WHEEL COVER	CHAPEAU DE MOYEU	CAPERUZA DE RUEDA
1	36	2	671 002 013		RAD	8"	WHEEL ASSY.	ROUE	RUEDA

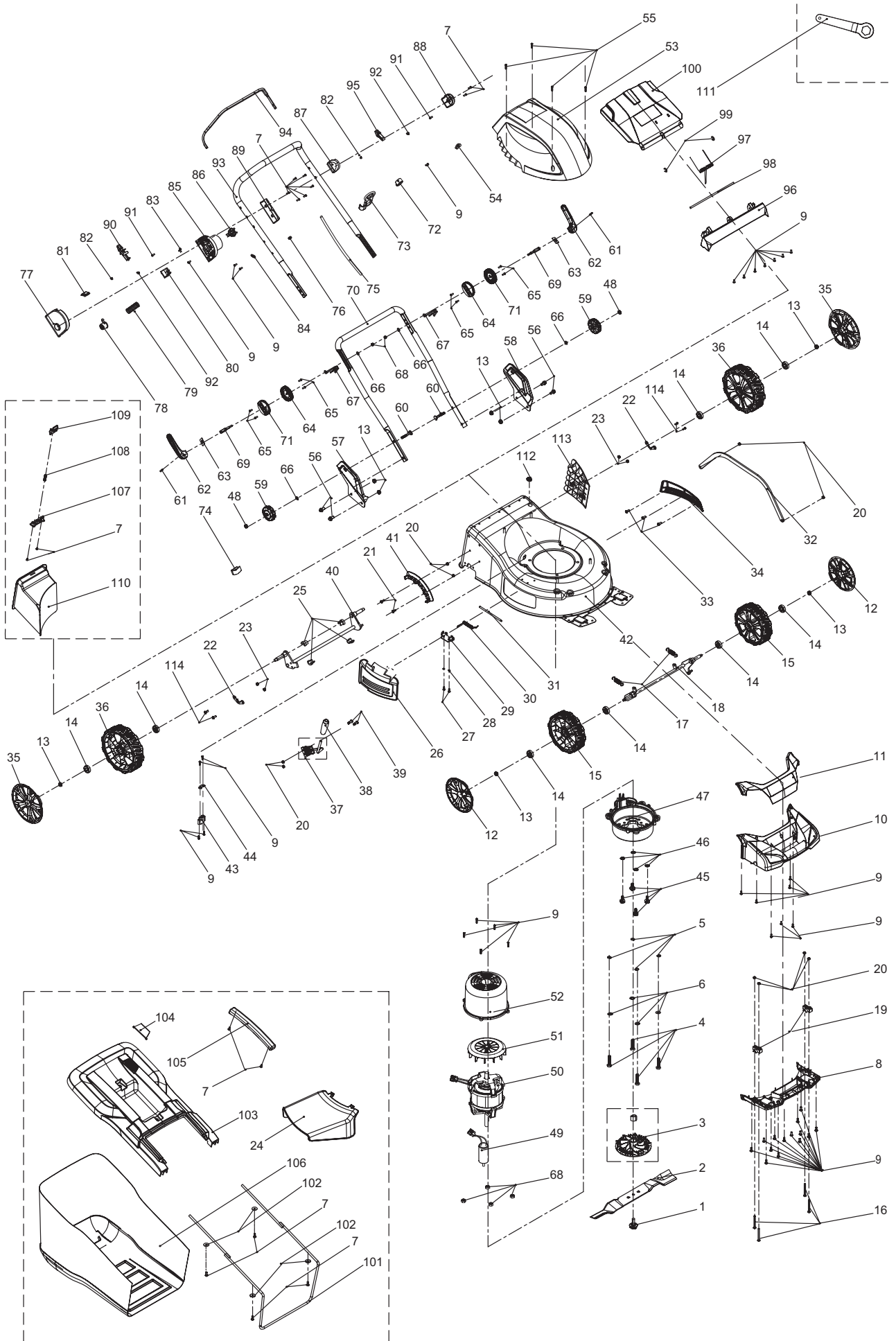

EM-461

1

EM-461, ELM4612
EM-461, ELM4612
EM-461, ELM4612
EM-461, ELM4612



 A member of the *Makita* Group

Seite / Page	Pos.	EM-461	Teil-Nr. Part No. No. de pièce No. de pieza	Hinweise Notes Renseign. Nota	Bezeichnung	Spezifikation Specification	Description	Désignation	Denominación
1	37	1	671 500 201		HEBEL, HÖHENVERSTELLUN G UND GRIFFUMHÜLLUNG KPL.	INC. 37,38	LEVER, HEIGHT ADJUSTMENT CPL.	LEVIER, REGLAGE HAUTEUR CPL.	PALANCA, AJUSTE ALTURA CPL.
1	38	1	671 500 201		HEBEL, HÖHENVERSTELLUN G UND GRIFFUMHÜLLUNG KPL.	INC. 37,38	LEVER, HEIGHT ADJUSTMENT CPL.	LEVIER, REGLAGE HAUTEUR CPL.	PALANCA, AJUSTE ALTURA CPL.
1	39	2	671 002 041		KREUZSCHLITZSCH RAUBE	M6*17	CROSS PAN BOLT	VIS	TORNILLO
1	40	1	671 002 363		HINTERRADACHSE KPL.		REAR WHEEL AXLE ASS'Y	AXE ROUE ARRIERESC	EJE RUEDAS TRASERASV
1	41	1	671 010 670		SEKTOR, HÖHENVERSTELLUN G		SECTOR, HEIGHT ADJUSTMENT	SECTEUR REGLAGE HAUTEUR	SECTOR, AJUSTE ALTURA
1	42	1	671 001 819		DECK	DOLMAR, RED	DECK	CAPOT	CAPOTA
1	43	1	671 260 001		KABELKLEMME		CABLE HOLDER	CRAMP	COLLIER DE SERRAGE
1	44	1	671 001 023		KABELKLEMME		CABLE HOLDER	CRAMP	COLLIER DE SERRAGE
1	45	4	671 001 009		SCHRAUBE		MOTOR TIGHTEN BOLT	VIS	TORNILLO
1	46	4	671 080 100		ZACKENRING		TOOTHED WASHER	RONDELLE DENTELLEE	ARANDELA DENTADA
1	47	1	671 627 001		MOTORGEHÄUSE UNTEN		WIND SLEEVE (LOWER)	CARTER MOTEUR INF.	CÁRTER MOTOR INF.
1	48	2	671 005 023		6KT-MUTTER	M8	HEXAGONAL NUT	ECROU HEXAGONAL	TUERCA HEXAGONAL
1	49	1	671 030 620		KONDENSATOR	VDE, 25µF	CAPACITOR	CONDENSATEUR	CONDENSADOR
1	50	1	671 002 018		ELEKTROMOTOR	CE/GS, 230V~50H z.1800W	ELECTRIC MOTOR	MOTEUR ÉLECTRIQUE	MOTOR ELÉCTRICO
1	51	1	671 327 001		LÜFTERRAD		FAN	ROUE DE VENTILATEUR	RODETE DEL VENTILADOR
1	52	1	671 625 001		MOTORGEHÄUSE OBEN		WIND SLEEVE (UPPER)	CARTER MOTEUR SUP.	CÁRTER MOTOR SUP.
1	53	1	671 931 001		MOTORABDECKUNG		MOTOR COVER	COUVERCLE MOTEUR	CUBIERTA DEL MOTOR
1	54	1	671 284 001		KABELDURCHFÜHR UNG		JACKET 2 OF CABLE CONNECTION	PASSE-FIL	BOQUILLA DE CAUCHO
1	55	4	671 003 079		SCHRAUBE	M5x12	ST SCREW	VIS	TORNILLO
1	56	4	671 006 064		6KT-SCHRAUBE	M8x6	HEXAGON HEAD BOLT	VIS À SIX PANS	TORNILLO HEXAGONAL
1	57	1	671 001 882		GRIFFANBINDUNG, RECHTS	DOLMAR, RED	BRACKET HANDLE, RIGHT	BRIDE DE POIGNÉE, DROITE	FIJACIÓN DE MANGO, DERECHA
1	58	1	671 001 881		GRIFFANBINDUNG, LINKS	DOLMAR, RED	BRACKET HANDLE, LEFT	BRIDE DE POIGNÉE, GAUCHE	FIJACIÓN DE MANGO, IZQ.
1	59	2	671 530 010		STERNGRIFF		STAR KNOB	MANETTE	MANIJA DE ESTRELLA
1	60	2	671 006 118		FLACHKOPFSCHRAU BE	M8x35	FLAT HEAD BOLT	VIS À TÊTE CYLINDRIQUE	TORNILLO DE CABEZA PLANA
1	61	2	671 005 141		VERSTELLGRIFF KPL.	INC. 61,62,63,69	SHIFT HANDLE CPL.	POIGNÉE DE RÉGLAGE CPL.	AGARRE AJUSTABLE CPL.
1	62	2	671 005 141		VERSTELLGRIFF KPL.	INC. 61,62,63,69	SHIFT HANDLE CPL.	POIGNÉE DE RÉGLAGE CPL.	AGARRE AJUSTABLE CPL.
1	63	2	671 005 141		VERSTELLGRIFF KPL.	INC. 61,62,63,69	SHIFT HANDLE CPL.	POIGNÉE DE RÉGLAGE CPL.	AGARRE AJUSTABLE CPL.
1	64	2	671 058 001		EINSTELLRING, UNTEN		LOWER ADJUSTING TOOTH RING	ANNEAU DE RÉGLAGE, INF.	ANILLO DE FLUJO, INF.
1	65	8	671 001 049		SCHRAUBE	3x10	BOLT	VIS	TORNILLO
1	66	4	671 011 890		FLACHSCHEIBE	φ16xφ8x0,8	FLAT WASHER	RONDELLE PLATE	ARANDELA
1	67	2	671 002 361		KABELHALTER		CABLE HOLDER	ATTACHE DE CÂBLE	SOPORTE DE CABLE

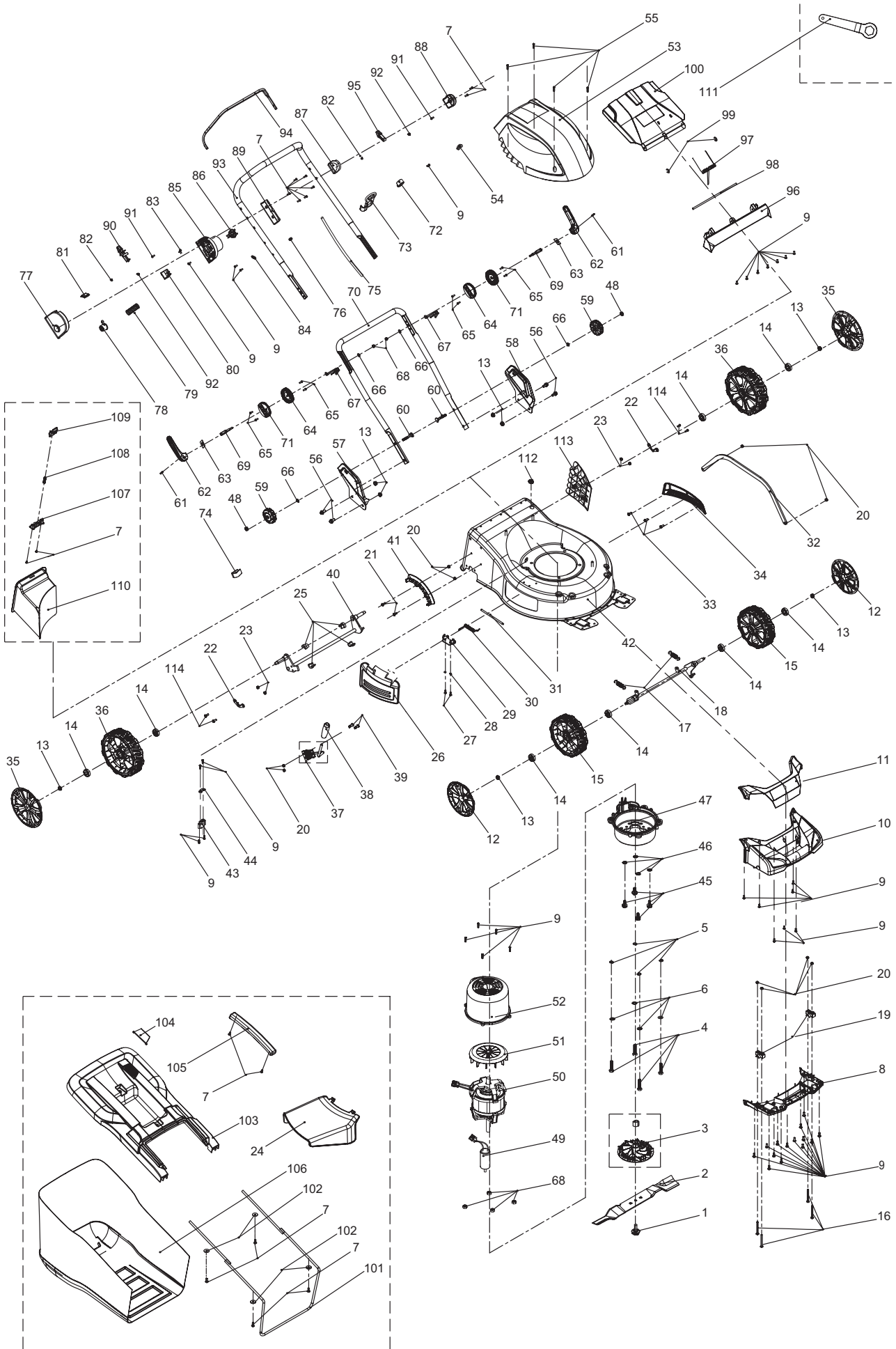

EM-461

1

EM-461, ELM4612
EM-461, ELM4612
EM-461, ELM4612
EM-461, ELM4612



 A member of the *Makita* Group

Seite / Page	Pos.	EM-461	Teil-Nr. Part No. No. de pièce No. de pieza	Hinweise Notes Renseign. Nota	Bezeichnung	Spezifikation Specification	Description	Désignation	Denominación
1	68	6	671 005 008		6KT-MUTTER	M8	HEXAGONAL LOCKING NUT	ECROU HEXAGONAL	TUERCA HEXAGONAL
1	69	2	671 005 141		VERSTELLGRIFF KPL.	INC. 61,62,63,69	SHIFT HANDLE CPL.	POIGNÉE DE RÉGLAGE CPL.	AGARRE AJUSTABLE CPL.
1	70	1	671 017 070		UNTERHOLM		LOWER HANDLE POLE	MANCHE INFÉRIEURE	MANGO INFERIOR
1	71	2	671 068 001		EINSTELLRING, OBEN		UPPER ADJUSTING TOOTH RING	ANNEAU DE RÉGLAGE, SUP.	ANILLO DE FLUJO, SUP.
1	72	1	671 800 102		KLEMMSCHELLE	Øi=24	BLOCK RING	COLLIER DE SERRAGE	ABRAZADERA DE SUJECIÓN
1	73	1	671 479 001		KABELHALTERUNG	Øi=26 (2010-05 =>)	CABLE HOLDER	ATTACHE POUR CÂBLES	SOPORTE DE CABLES
1	74	1	671 611 001		BOWDENZUGHALTE R		BOWDEN CABLE CLAMP	COLLIER DE SERRANGE	SOPORTE DE CABLE BOWDEN
1	75	1	671 001 072		VERBINDUNGSKABE L	1350mm	CABLE CONNECTION	CÂBLE	CABLE
1	76	1	671 283 001		KABELDURCHFÜHR UNG		JACKET 1 OF CABLE CONNECTION	PASSE-FIL	BOQUILLA DE CAUCHO
1	77	1	671 081 001		SCHALTERGEHÄUSE , RECHTS		SWITCH BOX, RIGHT	CARTER	CÂRTER
1	78	1	671 425 003		SICHERHEITSTASTE		SAFETY BUTTON	BOUCHON	BOTÓN
1	79	1	671 011 079		FEDER		SPRING OF SAFETY BUTTON	RESSORT	MUELLE
1	80	1	671 010 040		SCHALTER		SWITCH	INTERRUPTEUR	INTERRUPTOR
1	81	1	671 001 043		LAMPENABDECKUN G		LAMPSHADE	ABAT-JOUR	PANTALLA
1	82	2	671 001 021		SCHRAUBE SELBSTSCHNEIDEN D	ST4*10	SELF-TAPPING SCREW	VIS DE FORAGE	TORNILLO PERFORADOR
1	83	1	671 005 135		SCHALTERGEHÄUSE , LINKS VORMONTAGE	EU INC. 83,85,86	SWITCH BOX, LEFT ASSEMBLY	CARTER D'ASSEMBLAGE	CÂRTER DE MONTAJE
1	84	1	671 491 001		ZUGENTLASTUNG KABEL		STRAIN RELIEF CABLE	DÉCONTRACTION CÂBLE	CABLE DESCARGA DE TRACCIÓN
1	85	1	671 005 135		SCHALTERGEHÄUSE , LINKS VORMONTAGE	EU INC. 83,85,86	SWITCH BOX, LEFT ASSEMBLY	CARTER D'ASSEMBLAGE	CÂRTER DE MONTAJE
1	86	1	671 005 135		SCHALTERGEHÄUSE , LINKS VORMONTAGE	EU INC. 83,85,86	SWITCH BOX, LEFT ASSEMBLY	CARTER D'ASSEMBLAGE	CÂRTER DE MONTAJE
1	87	1	671 084 001		GRIFFTRÄGER RECHTS		RIGHT HANDLE SUPPORT	SUPPORT DE POIGNÉE DROITE	SOPORTE DE ASA DERECHO
1	88	1	671 083 001		GRIFFTRÄGER LINKS		LEFT HANDLE SUPPORT	SUPPORT DE POIGNÉE GAUCHE	SOPORTE DE ASA IZQUIERDO
1	89	1	671 451 001		DRUCKPLATTE		PRESSING PLATE OF SWITCH BOX	PLAQUE	PLACA
1	90	1	671 072 001		STECKVERBINDUNG, RECHTS		RIGHT PLUG-IN OF HANDLE	CONNECTEUR, DROITE	CONEXIÓN, DERECHA
1	91	2	671 001 036		SCHRAUBE SELBSTSCHNEIDEN D	3x10	SELF-TAPPING SCREW	VIS DE FORAGE	TORNILLO PERFORADOR
1	92	2	671 011 124		FEDER		SPRING	RESSORT	MUELLE
1	93	1	671 001 706		OBERHOLM		UPPER HANDLE	MANCHE SUPÉRIEURE	MANGO SUPERIOR
1	94	1	671 001 852		HEBEL, MOTORBREMSE		LEVER, MOTOR BRAKE	LEVIER FREIN MOTEUR	PALANCA, FRENO MOTOR
1	95	1	671 071 001		STECKVERBINDUNG, LINKS		LEFT PLUG-IN OF HANDLE	CONNECTEUR, GAUCHE	CONEXIÓN, IZQ.
1	96	1	671 932 002		ABDECKUNG	DOLMAR, RED	COVER	COUVERCLE	CUBIERTA
1	97	1	671 011 203		FEDER		SPRING	RESSORT	MUELLE
1	98	1	671 002 365		STANGE		LONG POLE	TRINGLE	BARRA
1	99	2	671 009 017		KLEMMRING		OPEN BLOCK RING	ANNEAU	ANILLO
1	100	1	671 933 002		HECKKLAPPE	DOLMAR, RED	REAR COVER	HAYON	PORTÓN TRASERO

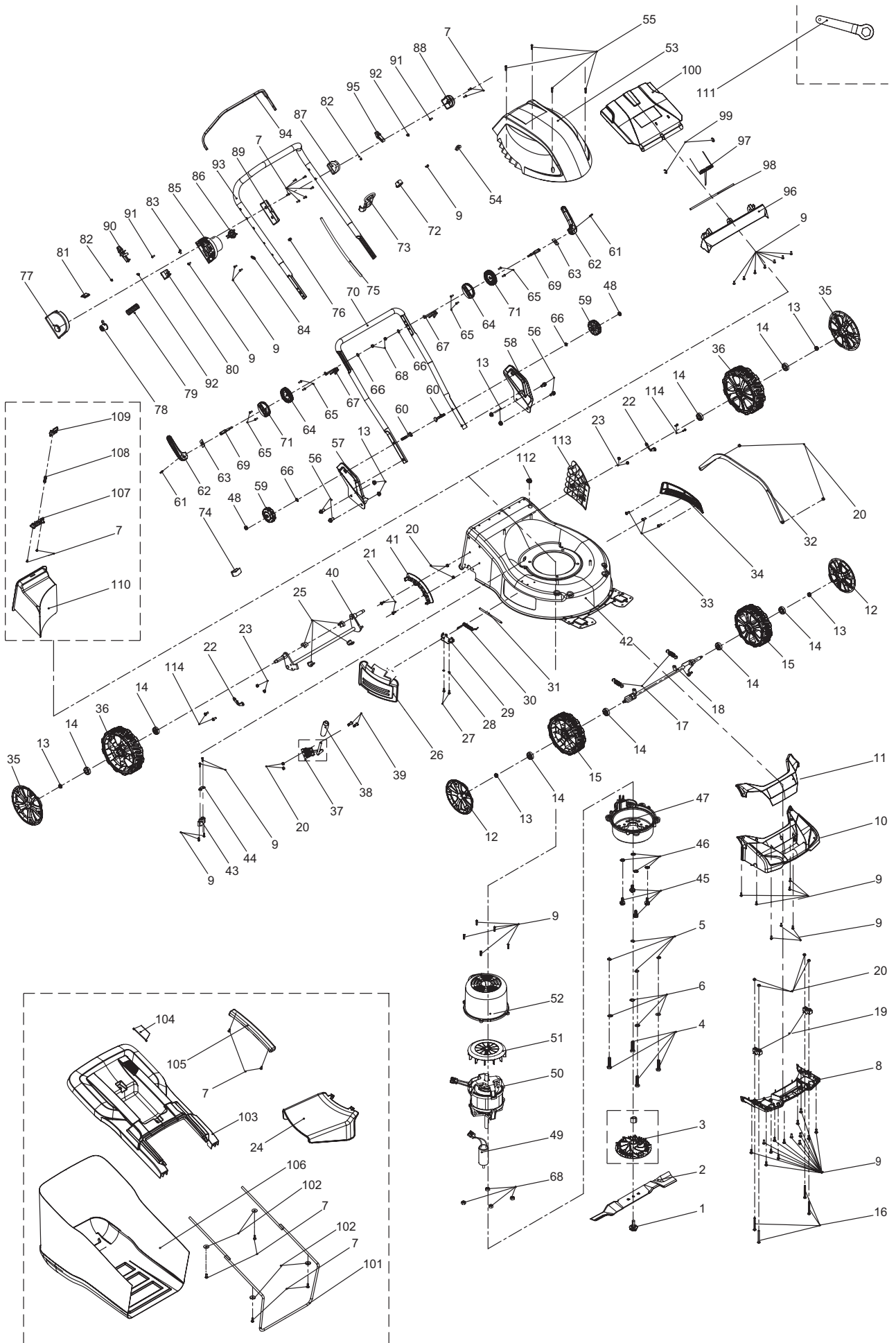

EM-461

1

EM-461, ELM4612
EM-461, ELM4612
EM-461, ELM4612
EM-461, ELM4612
DOLMAR

 A member of the *Makita* Group

Seite / Page	Pos.	EM-461	Teil-Nr. Part No. No. de pièce No. de pieza	Hinweise Notes Renseign. Nota	Bezeichnung	Spezifikation Specification	Description	Désignation	Denominación
1	101	1	671 002 366		RAHMEN		GRASS CATCHER BRACKET	CADRE	MARKO
1	102	4	671 001 436		SCHEIBE	φ5*φ24*2	TIGHTEN PRESSING PLATE	RONDELLE	ARANDELA
1	103	1	671 992 001		KORB, OBERTEIL		GRASS-BOX, UPPER	SAC, PARTIE	CESTO, SUPERIOR
1	104	1	671 010 780		FÜLLSTANDSANZEIG ER	DOLMAR, RED	LEVEL INDICATOR	INDICATEUR NIVEAU	INDICADOR DE NIVEL
1	105	1	671 937 001		HANDGRIFF		HANDLE OF GRASS CATCHER	POIGNÉE	MANGO
1	106	1	671 153 402		GRASFANGKORB	18" DOLMAR	GRASS CATCHER	SAC	CESTO
1	107	1	671 317 001		DRUCKPLATTE		PRESSING PLATE	PLAQUE	PLACA
1	108	1	671 011 005		FEDER	φ8.0*φ0.9*31mm	SPRING	RESSORT	MUELLE
1	109	1	671 316 004		VERRIEGELUNGSKN OPF	20"	LOCKING BUTTON	TÊTE DE VERROUILLAGE	BOTÓN DE BLOQUEO
1	110	1	671 936 001		MULCHKEIL		MULCHING KIT	KIT MULCH	KIT DE MANTILLO
1	111	1	671 002 009		RINGSCHLÜSSEL		BOX SPANNER	CLÉ POLYGONALE	LLAVE DE ESTRÍAS
1	112	1	671 800 104		GUMMITÜLLE		CORD PROTECTING SHEATH	PASSE-FIL	BOQUILLA DE CAUCHO
1	113	1	671 085 001		ABDECKUNG		SIDE DISCHARGE BOARD	COUVERCLE	CUBIERTA
1	114	4	671 002 019		SCHRAUBE	M6x12	TRIGGER BOLT	VIS	TORNILLO

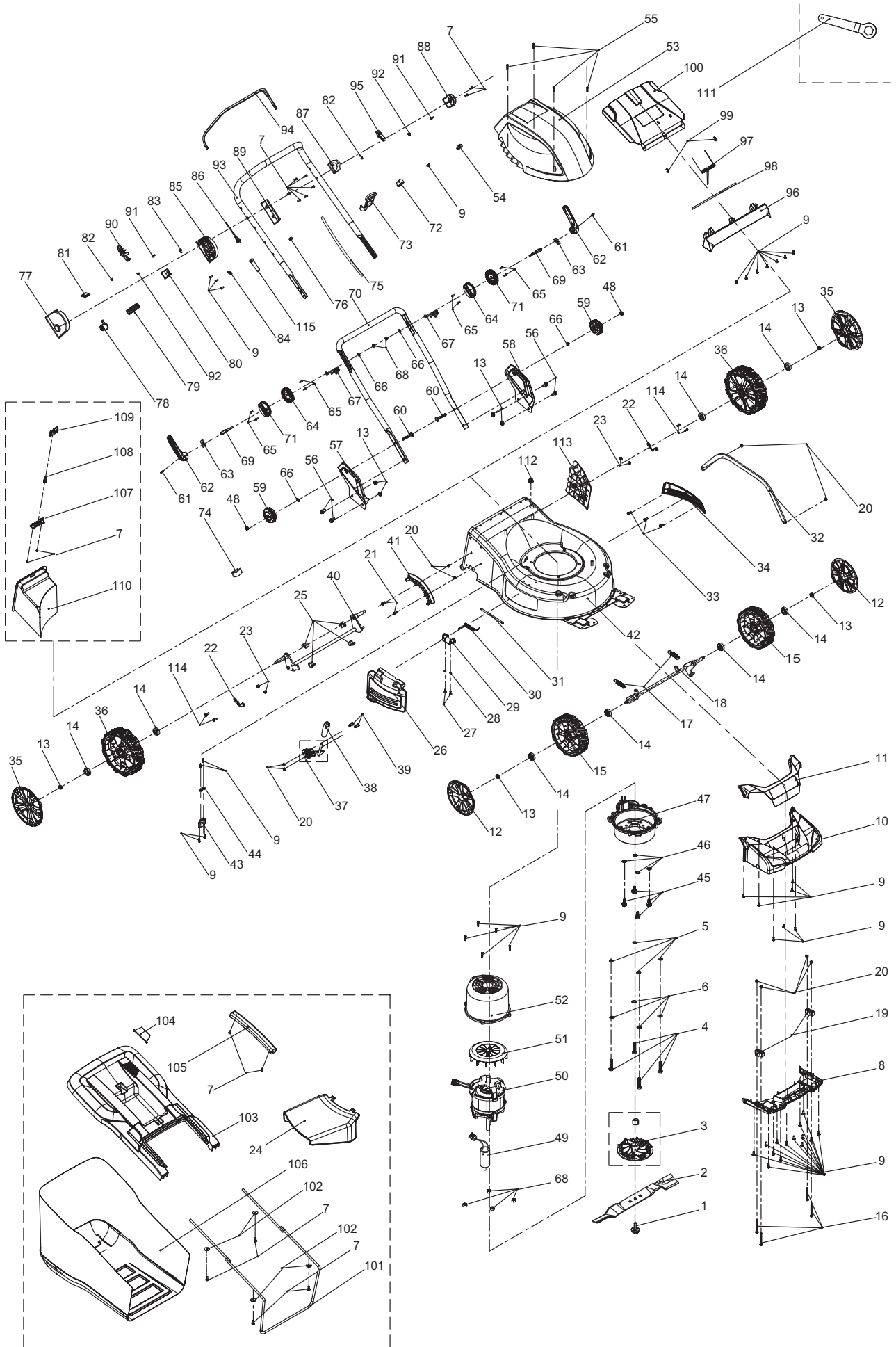

EM-461

2

EM-461, ELM4612 (CH)
EM-461, ELM4612 (CH)
EM-461, ELM4612 (CH)
EM-461, ELM4612 (CH)**DOLMAR**
A member of the *Makita* Group

Seite / Page	Pos.	EM-461	Teil-Nr. Part No. No. de pièce No. de pieza	Hinweise Notes Renseign. Nota	Bezeichnung	Spezifikation Specification	Description	Désignation	Denominación
2	1	1	671 100 802		MESSERSCHRAUBE	M10*1.35*40	BLADE TIGHTEN BOLT	VIS DE LAME	TORNILLO DE LA CUCHILLA
2	2	1	671 146 102		MESSER	460X55X3mm	BLADE	LAME	CUCHILLA
2	3	1	671 005 057		MESSERHALTER		HUB	MOYEU	SOPORTE DE LA CUCHILLA
2	4	4	671 006 025		6KT-SCHRAUBE	M8x35	HEXAGON BOLT	VIS À SIX PANS	TORNILLO HEXAGONAL
2	5	4	671 008 002		FEDERRING	φ8,65	SPRING RING	RONDELLE À RESSORT	ANILLO ELÁSTICO
2	6	4	671 007 007		SCHEIBE	φ8	WASHER	RONDELLE	ARANDELA
2	7	16	671 001 005		SCHRAUBE SELBSTSCHNEIDEN D	4x16	SELF-TAPPING SCREW	VIS DE FORAGE	TORNILLO PERFORADOR
2	8	1	671 927 001		FRONTTEILTRÄGER		FRONT COVER SUPPORT	SUPPORT	SOPORTE
2	9	41	671 001 003		SCHRAUBE SELBSTSCHNEIDEN D	4x12	SELF-TAPPING SCREW	VIS DE FORAGE	TORNILLO PERFORADOR
2	10	1	671 926 001		FRONTTEIL		FRONT COVER	PANNEAU	FRONTAL CUBIERTA
2	11	1	671 925 001		FRONTTEILABDECKUNG		FRONT COVER BOARD	COUVERCLE	CUBIERTA
2	12	2	671 003 014		RADKAPPE	7"	WHEEL COVER	CHAPEAU DE MOYEU	CAPERUZA DE RUEDA
2	13	8	671 005 028		6KT-MUTTER	M8	HEXAGONAL LOCKING NUT	ECROU HEXAGONAL	TUERCA HEXAGONAL
2	14	8	671 004 012		KUGELLAGER	6201Z	BALL BEARING	ROULEMENT À BILLES	RODAMIENTO DE BOLAS
2	15	2	671 002 012		RAD	7"	WHEEL ASSY.	ROUE	RUEDA
2	16	4	671 006 119		SCHRAUBE	M6x60mm	BOLT	VIS	TORNILLO
2	17	2	671 011 230		FEDER		SPRING OF FRONT WHEEL AXLE	RESSORT	MUELLE
2	18	1	671 002 362		VORDERACHSE KPL.	333mm	FRONT WHEEL AXLE ASS'Y	ESSIEU AVANT CPL.	EJE DELANTERO CPL.
2	19	2	671 445 001		LAGERSCHALE		AXLE SHEATH	PLAQUETTE	COJINETE
2	20	10	671 005 005		6KT-MUTTER	M6	LOCKING NUT	ECROU	TUERCA
2	21	2	671 002 020		SCHRAUBE	M6x16	TRIGGER BOLT	VIS	TORNILLO
2	22	2	671 001 244		FIXIERUNG		RING OF AXLE FIXING	FIXATION	FIJACIÓN
2	23	4	671 005 024		6KT-MUTTER	M6	HEXAGONAL LOCKING NUT	ECROU HEXAGONAL	TUERCA HEXAGONAL
2	24	1	671 930 001		SCHUTZHAUBE SEITENAUSWURF		SIDE DISCHARGE PROTECTING COVER	CAPOT DE PROTECTION	CUBIERTA PROTECTORA
2	25	4	671 340 002		LAGERSCHALE		AXLE SHEATH	PLAQUETTE	COJINETE
2	26	1	671 929 001		MULCHABDECKUNG		SIDE DISCHARGE COVER BOARD	COUVERCLE	CUBIERTA
2	27	2	671 002 010		SCHRAUBE	M5x12	TRIGGER BOLT	VIS	TORNILLO
2	28	2	671 080 040		FEDERSCHEIBE		SPRING WASHER	RONDELLE A RESSORT	ARANDELA ELASTICO
2	29	1	671 001 571		FIXIERBLECH		FIXED PLATE	FIXATION	FIJACIÓN
2	30	1	671 011 205		FEDER		SPRING OF SIDE DISCHARGE COVER BOARD	RESSORT	RESORTE
2	31	1	671 001 019		ACHSE		AXLE	AXE	EJE
2	32	1	671 002 364		VERBINDUNGSSTANGE		LINK ROD	BARRE DE RACCORDEMENT	BARRA DE CONEXIÓN
2	33	3	671 010 310		SCHRAUBE SELBSTSCHNEIDEN D	4.2*8	SELF-TAPPING SCREW	VIS DE FORAGE	TORNILLO PERFORADOR
2	34	1	671 928 001		SCHUTZABDECKUNG		PROTECTING HOOD	CAPOT PROTECTEUR	CUBIERTA PROTECTORA
2	35	2	671 030 150		RADKAPPE	8"	WHEEL COVER	CHAPEAU DE MOYEU	CAPERUZA DE RUEDA
2	36	2	671 002 013		RAD	8"	WHEEL ASSY.	ROUE	RUEDA

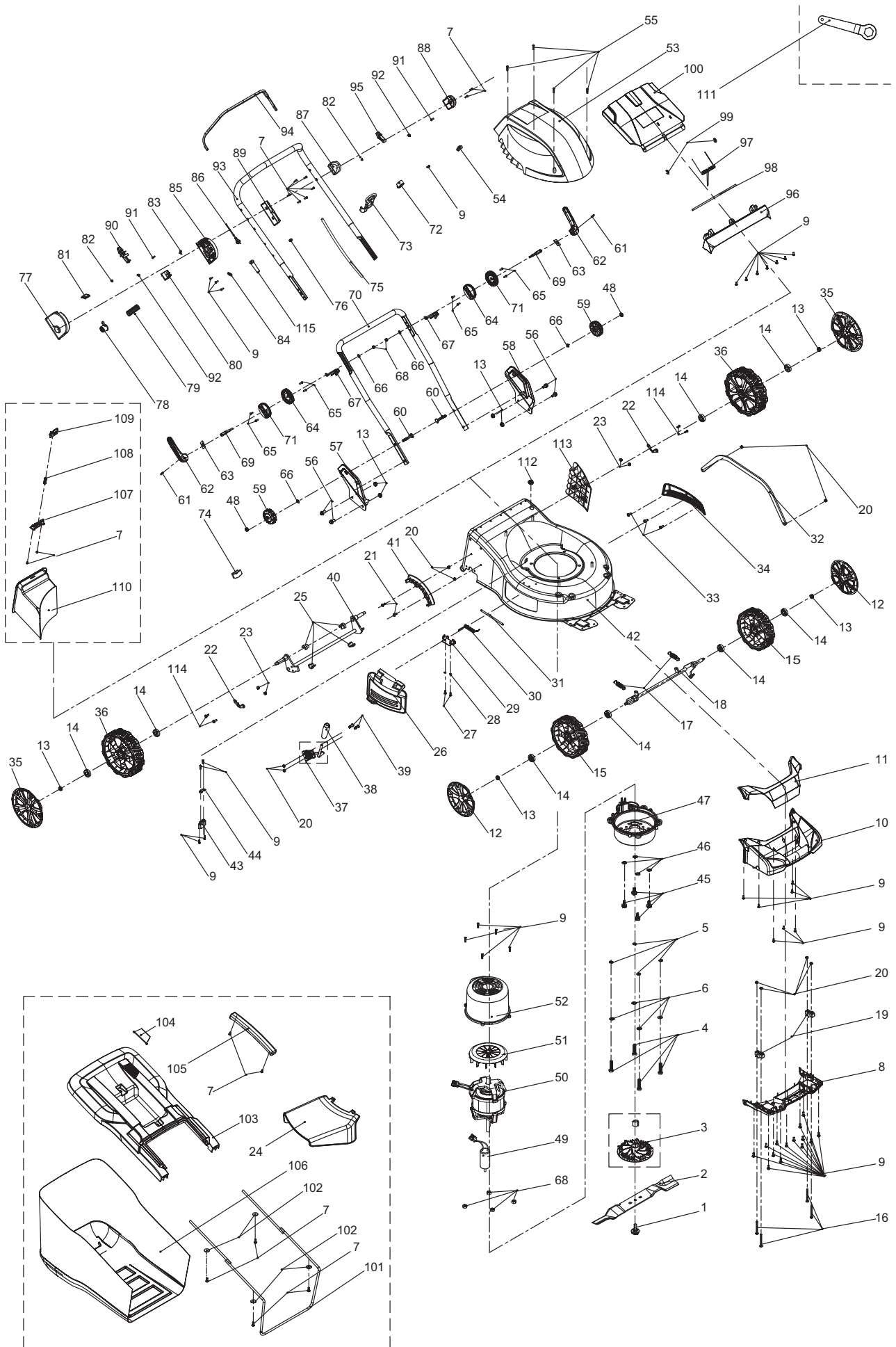

EM-461

2

EM-461, ELM4612 (CH)
EM-461, ELM4612 (CH)
EM-461, ELM4612 (CH)
EM-461, ELM4612 (CH)



 A member of the *Makita* Group

Seite / Page	Pos.	EM-461	Teil-Nr. Part No. No. de pièce No. de pieza	Hinweise Notes Renseign. Nota	Bezeichnung	Spezifikation Specification	Description	Désignation	Denominación
2	37	1	671 500 201		HEBEL, HÖHENVERSTELLUN G UND GRIFFUMHÜLLUNG KPL.	INC. 37,38	LEVER, HEIGHT ADJUSTMENT CPL.	LEVIER, REGLAGE HAUTEUR CPL.	PALANCA, AJUSTE ALTURA CPL.
2	38	1	671 500 201		HEBEL, HÖHENVERSTELLUN G UND GRIFFUMHÜLLUNG KPL.	INC. 37,38	LEVER, HEIGHT ADJUSTMENT CPL.	LEVIER, REGLAGE HAUTEUR CPL.	PALANCA, AJUSTE ALTURA CPL.
2	39	2	671 002 041		KREUZSCHLITZSCH RAUBE	M6*17	CROSS PAN BOLT	VIS	TORNILLO
2	40	1	671 002 363		HINTERRADACHSE KPL.		REAR WHEEL AXLE ASS'Y	AXE ROUE ARRIERESC	EJE RUEDAS TRASERASV
2	41	1	671 010 670		SEKTOR, HÖHENVERSTELLUN G		SECTOR, HEIGHT ADJUSTMENT	SECTEUR REGLAGE HAUTEUR	SECTOR, AJUSTE ALTURA
2	42	1	671 001 819		DECK	DOLMAR, RED	DECK	CAPOT	CAPOTA
2	43	1	671 260 001		KABELKLEMME		CABLE HOLDER	CRAMP	COLLIER DE SERRAGE
2	44	1	671 001 023		KABELKLEMME		CABLE HOLDER	CRAMP	COLLIER DE SERRAGE
2	45	4	671 001 009		SCHRAUBE		MOTOR TIGHTEN BOLT	VIS	TORNILLO
2	46	4	671 080 100		ZACKENRING		TOOTHED WASHER	RONDELLE DENTELLEE	ARANDELA DENTADA
2	47	1	671 627 001		MOTORGEHÄUSE UNTEN		WIND SLEEVE (LOWER)	CARTER MOTEUR INF.	CÁRTER MOTOR INF.
2	48	2	671 005 023		6KT-MUTTER	M8	HEXAGONAL NUT	ECROU HEXAGONAL	TUERCA HEXAGONAL
2	49	1	671 030 620		KONDENSATOR	VDE, 25µF	CAPACITOR	CONDENSATEUR	CONDENSADOR
2	50	1	671 002 018		ELEKTROMOTOR	CE/GS,230V~50H z,1800W	ELECTRIC MOTOR	MOTEUR ÉLECTRIQUE	MOTOR ELÉCTRICO
2	51	1	671 327 001		LÜFTERRAD		FAN	ROUE DE VENTILATEUR	RODETE DEL VENTILADOR
2	52	1	671 625 001		MOTORGEHÄUSE OBEN		WIND SLEEVE (UPPER)	CARTER MOTEUR SUP.	CÁRTER MOTOR SUP.
2	53	1	671 931 001		MOTORABDECKUNG		MOTOR COVER	COUVERCLE MOTEUR	CUBIERTA DEL MOTOR
2	54	1	671 284 001		KABELDURCHFÜHR UNG		JACKET 2 OF CABLE CONNECTION	PASSE-FIL	BOQUILLA DE CAUCHO
2	55	4	671 003 079		SCHRAUBE	M5x12	ST SCREW	VIS	TORNILLO
2	56	4	671 006 064		6KT-SCHRAUBE	M8x6	HEXAGON HEAD BOLT	VIS À SIX PANS	TORNILLO HEXAGONAL
2	57	1	671 001 882		GRIFFANBINDUNG, RECHTS	DOLMAR, RED	BRACKET HANDLE, RIGHT	BRIDE DE POIGNÉE, DROITE	FIJACIÓN DE MANGO, DERECHA
2	58	1	671 001 881		GRIFFANBINDUNG, LINKS	DOLMAR, RED	BRACKET HANDLE, LEFT	BRIDE DE POIGNÉE, GAUCHE	FIJACIÓN DE MANGO, IZQ.
2	59	2	671 530 010		STERNGRIFF		STAR KNOB	MANETTE	MANIJA DE ESTRELLA
2	60	2	671 006 118		FLACHKOPFSCHRAU BE	M8x35	FLAT HEAD BOLT	VIS À TÊTE CYLINDRIQUE	TORNILLO DE CABEZA PLANA
2	61	2	671 005 141		VERSTELLGRIFF KPL.	INC. 61,62,63,69	SHIFT HANDLE CPL.	POIGNÉE DE RÉGLAGE CPL.	AGARRE AJUSTABLE CPL.
2	62	2	671 005 141		VERSTELLGRIFF KPL.	INC. 61,62,63,69	SHIFT HANDLE CPL.	POIGNÉE DE RÉGLAGE CPL.	AGARRE AJUSTABLE CPL.
2	63	2	671 005 141		VERSTELLGRIFF KPL.	INC. 61,62,63,69	SHIFT HANDLE CPL.	POIGNÉE DE RÉGLAGE CPL.	AGARRE AJUSTABLE CPL.
2	64	2	671 058 001		EINSTELLRING, UNTEN		LOWER ADJUSTING TOOTH RING	ANNEAU DE RÉGLAGE, INF.	ANILLO DE FLUJO, INF.
2	65	8	671 001 049		SCHRAUBE	3x10	BOLT	VIS	TORNILLO
2	66	4	671 011 890		FLACHSCHEIBE	φ16xφ8x0,8	FLAT WASHER	RONDELLE PLATE	ARANDELA
2	67	2	671 002 361		KABELHALTER		CABLE HOLDER	ATTACHE DE CÂBLE	SOPORTE DE CABLE

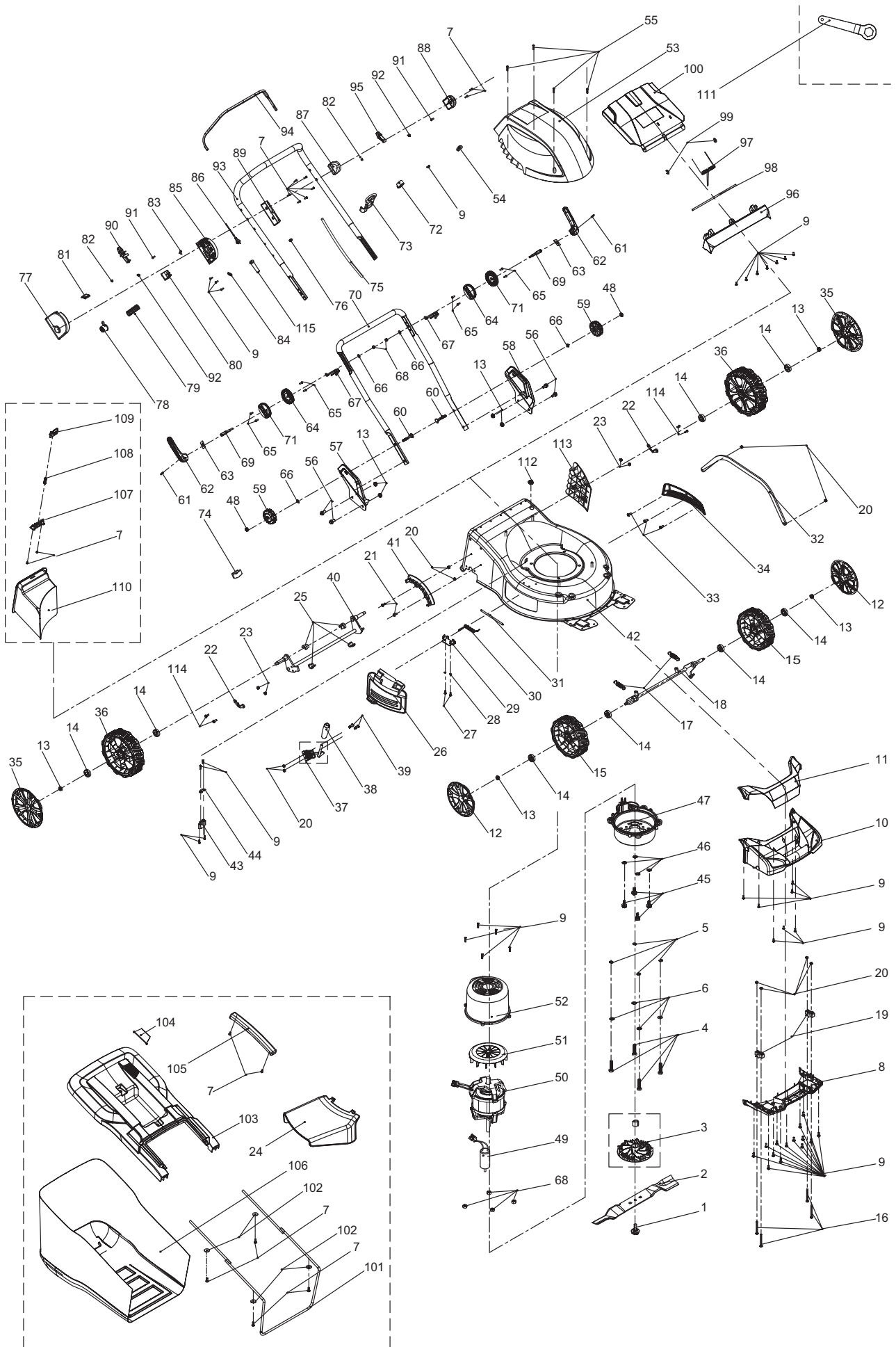

EM-461

2

EM-461, ELM4612 (CH)
EM-461, ELM4612 (CH)
EM-461, ELM4612 (CH)
EM-461, ELM4612 (CH)



 A member of the *Makita* Group

Seite / Page	Pos.	EM-461	Teil-Nr. Part No. No. de pièce No. de pieza	Hinweise Notes Renseign. Nota	Bezeichnung	Spezifikation Specification	Description	Désignation	Denominación
2	68	6	671 005 008		6KT-MUTTER	M8	HEXAGONAL LOCKING NUT	ECROU HEXAGONAL	TUERCA HEXAGONAL
2	69	2	671 005 141		VERSTELLGRIF KPL.	INC. 61,62,63,69	SHIFT HANDLE CPL.	POIGNÉE DE RÉGLAGE CPL.	AGARRE AJUSTABLE CPL.
2	70	1	671 017 070		UNTERHOLM		LOWER HANDLE POLE	MANCHE INFÉRIEURE	MANGO INFERIOR
2	71	2	671 068 001		EINSTELLRING, OBEN		UPPER ADJUSTING TOOTH RING	ANNEAU DE RÉGLAGE, SUP.	ANILLO DE FLUJO, SUP.
2	72	1	671 800 102		KLEMMSCHELLE	Øi=24	BLOCK RING	COLLIER DE SERRAGE	ABRAZADERA DE SUJECIÓN
2	73	1	671 479 001		KABELHALTERUNG	Øi=26 (2010-05 =>)	CABLE HOLDER	ATTACHE POUR CÂBLES	SOPORTE DE CABLES
2	74	1	671 611 001		BOWDENZUGHALTE R		BOWDEN CABLE CLAMP	COLLIER DE SERRANGE	SOPORTE DE CABLE BOWDEN
2	75	1	671 001 072		VERBINDUNGSKABE L	1350mm	CABLE CONNECTION	CÂBLE	CABLE
2	76	1	671 283 001		KABELDURCHFÜHR UNG		JACKET 1 OF CABLE CONNECTION	PASSE-FIL	BOQUILLA DE CAUCHO
2	77	1	671 082 001		SCHALTERGEHÄUSE , RECHTS		SWITCH BOX, RIGHT	CARTER	CÂRTER
2	78	1	671 425 003		SICHERHEITSTASTE		SAFETY BUTTON	BOUCHON	BOTÓN
2	79	1	671 011 079		FEDER		SPRING OF SAFETY BUTTON	RESSORT	MUELLE
2	80	1	671 010 040		SCHALTER		SWITCH	INTERRUPTEUR	INTERRUPTOR
2	81	1	671 001 043		LAMPENABDECKUN G		LAMPSHADE	ABAT-JOUR	PANTALLA
2	82	2	671 001 021		SCHRAUBE SELBSTSCHNEIDEN D	ST4*10	SELF-TAPPING SCREW	VIS DE FORAGE	TORNILLO PERFORADOR
2	83	1	671 005 142		KABEL MIT STECKER, SATZ	CH INC. 83,86,115	CABLE WITH PLUG ASSY	CABLE AVEC PRISE SET	CABLE CON ENCHUFE SET
2	84	1	671 263 001		ZUGENTLASTUNG		CABLE PRESSING PLATE	DÉCONTRACTION	DESCARGA DE TRACCIÓN
2	85	1	671 077 001		SCHALTERGEHÄUSE , LINKS		SWITCH BOX, LEFT	CARTER	CÂRTER
2	86	1	671 005 142		KABEL MIT STECKER, SATZ	CH INC. 83,86,115	CABLE WITH PLUG ASSY	CABLE AVEC PRISE SET	CABLE CON ENCHUFE SET
2	87	1	671 084 001		GRIFFRÄGER RECHTS		RIGHT HANDLE SUPPORT	SUPPORT DE POIGNÉE DROITE	SOPORTE DE ASA DERECHO
2	88	1	671 083 001		GRIFFRÄGER LINKS		LEFT HANDLE SUPPORT	SUPPORT DE POIGNÉE GAUCHE	SOPORTE DE ASA IZQUIERDO
2	89	1	671 451 001		DRUCKPLATTE		PRESSING PLATE OF SWITCH BOX	PLAQUE	PLACA
2	90	1	671 072 001		STECKVERBINDUNG, RECHTS		RIGHT PLUG-IN OF HANDLE	CONNECTEUR, DROITE	CONEXIÓN, DERECHA
2	91	2	671 001 036		SCHRAUBE SELBSTSCHNEIDEN D	3x10	SELF-TAPPING SCREW	VIS DE FORAGE	TORNILLO PERFORADOR
2	92	2	671 011 124		FEDER		SPRING	RESSORT	MUELLE
2	93	1	671 001 706		OBERHOLM		UPPER HANDLE	MANCHE SUPÉRIEURE	MANGO SUPERIOR
2	94	1	671 001 852		HEBEL, MOTORBREMSE		LEVER, MOTOR BRAKE	LEVIER FREIN MOTEUR	PALANCA, FRENO MOTOR
2	95	1	671 071 001		STECKVERBINDUNG, LINKS		LEFT PLUG-IN OF HANDLE	CONNECTEUR, GAUCHE	CONEXIÓN, IZQ.
2	96	1	671 932 002		ABDECKUNG	DOLMAR, RED	COVER	COUVERCLE	CUBIERTA
2	97	1	671 011 203		FEDER		SPRING	RESSORT	MUELLE
2	98	1	671 002 365		STANGE		LONG POLE	TRINGLE	BARRA
2	99	2	671 009 017		KLEMMRING		OPEN BLOCK RING	ANNEAU	ANILLO
2	100	1	671 933 002		HECKKLAPPE	DOLMAR, RED	REAR COVER	HAYON	PORTÓN TRASERO
2	101	1	671 002 366		RAHMEN		GRASS CATCHER BRACKET	CADRE	MARKO
2	102	4	671 001 436		SCHEIBE	φ5*φ24*2	TIGHTEN PRESSING PLATE	RONDELLE	ARANDELA

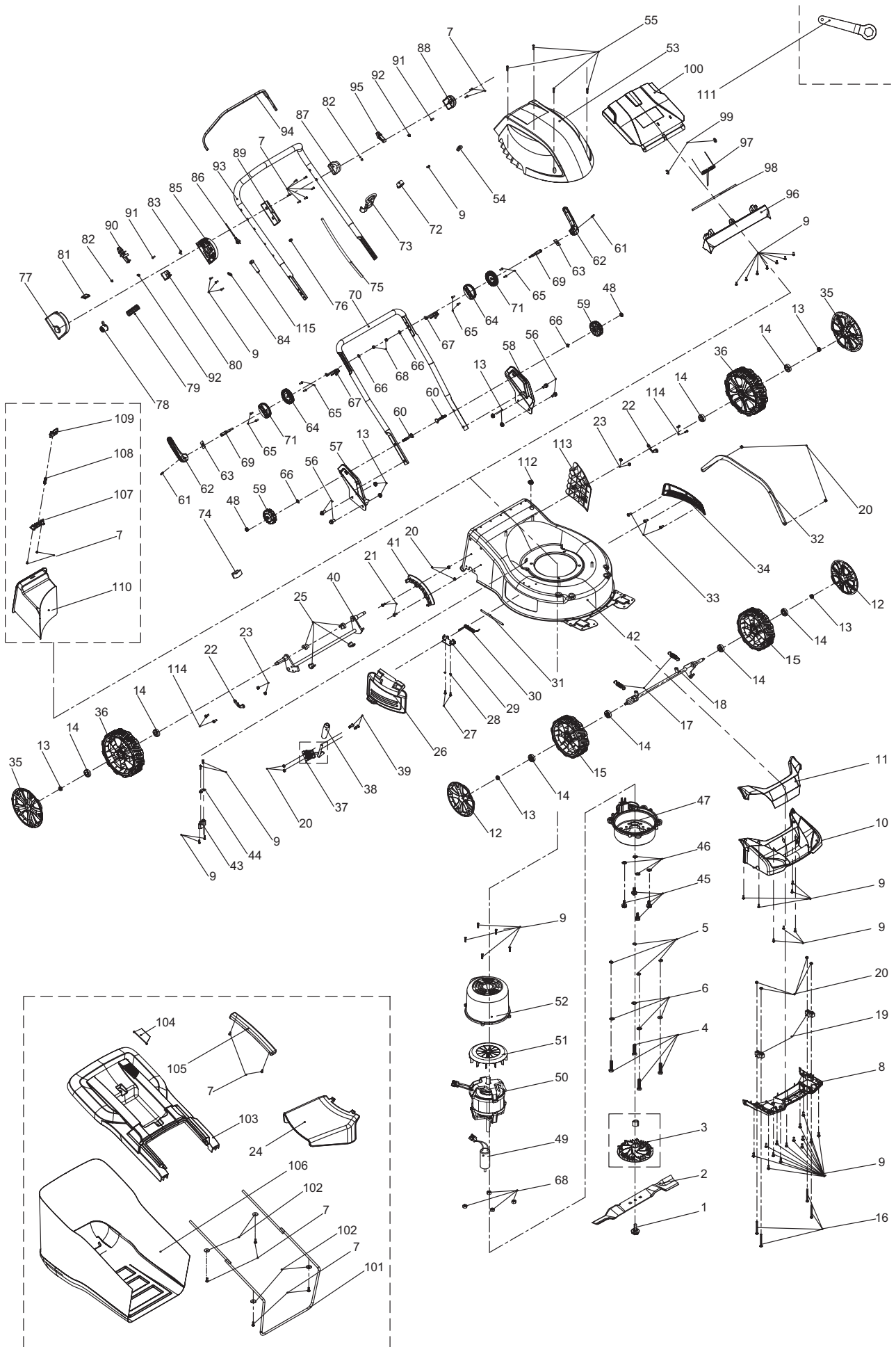

EM-461

2

EM-461, ELM4612 (CH)
 EM-461, ELM4612 (CH)
 EM-461, ELM4612 (CH)
 EM-461, ELM4612 (CH)

DOLMAR

 A member of the *Makita* Group

Seite / Page	Pos.	EM-461	Teil-Nr. Part No. No. de pièce No. de pieza	Hinweise Notes Renseign. Nota	Bezeichnung	Spezifikation Specification	Description	Désignation	Denominación
2	103	1	671 992 001		KORB, OBERTEIL		GRASS-BOX, UPPER	SAC, PARTIE	CESTO, SUPERIOR
2	104	1	671 010 780		FÜLLSTANDSANZEIGER	DOLMAR, RED	LEVEL INDICATOR	INDICATEUR NIVEAU	INDICADOR DE NIVEL
2	105	1	671 937 001		HANDGRIFF		HANDLE OF GRASS CATCHER	POIGNÉE	MANGO
2	106	1	671 153 402		GRASFANGKORB	18" DOLMAR	GRASS CATCHER	SAC	CESTO
2	107	1	671 317 001		DRUCKPLATTE		PRESSING PLATE	PLAQUE	PLACA
2	108	1	671 011 005		FEDER	φ8.0*φ0.9*31mm	SPRING	RESSORT	MUELLE
2	109	1	671 316 004		VERRIEGELUNGSKNOPF	20"	LOCKING BUTTON	TÊTE DE VERROUILLAGE	BOTÓN DE BLOQUEO
2	110	1	671 936 001		MULCHKEIL		MULCHING KIT	KIT MULCH	KIT DE MANTILLO
2	111	1	671 002 009		RINGSCHLÜSSEL		BOX SPANNER	CLÉ POLYGONALE	LLAVE DE ESTRÍAS
2	112	1	671 800 104		GUMMITÜLLE		CORD PROTECTING SHEATH	PASSE-FIL	BOQUILLA DE CAUCHO
2	113	1	671 085 001		ABDECKUNG		SIDE DISCHARGE BOARD	COUVERCLE	CUBIERTA
2	114	4	671 002 019		SCHRAUBE	M6x12	TRIGGER BOLT	VIS	TORNILLO
2	115	1	671 005 142		KABEL MIT STECKER, SATZ	CH INC. 83,86,115	CABLE WITH PLUG ASSY	CABLE AVEC PRISE SET	CABLE CON ENCHUFE SET

1

 EM-461, ELM4612
 EM-461, ELM4612
 EM-461, ELM4612
 EM-461, ELM4612

2

 EM-461, ELM4612 (CH)
 EM-461, ELM4612 (CH)
 EM-461, ELM4612 (CH)
 EM-461, ELM4612 (CH)

	Zeichenerklärung	Key to symbols
=> 1999999 2000000 => 2003.04 => TI 2003/07 Acc. = { m Corr.	Produktion bis Serien-Nr. Neues Teil ab Serien-Nr. Neues Teil ab Jahr / Monat Siehe Technische Information Jahr / Nr. Zubehör (nicht im Lieferumfang) Keine Serienausführung, jedoch verwendbar Beinhaltet Positions-Nr. Meterware Druckfehlerberichtigung	Production to serial number New part from serial number New part from Year / Month See Technical Information Year / No. Accessories (not included in the delivery inventory) No standard execution, may be used Contains item number Sold by the meter Error correction
	Änderungen vorbehalten	Specifications subject to change without notice
	Légende	Explicación de símbolos
=> 1999999 2000000 => 2003.04 => TI 2003/07 Acc. = { m Corr.	Production jusqu'à n° de série Nouveau pièce à partir du n° de série Nouveau pièce à partir de année / mois Voir information technique année / n° Accessoires (non compris dans la livraison) Aucune exécut. en série, cependant utilisable contient n° de numéro Au mètre Rectification d'erreurs	Producción hasta N° de serie Pieza nueva a partir de N° de serie Pieza nueva a partir de año / mes Véase inform. técnico año / N° Accesorios (no incluido en la extensión del suministro) No es de serie, pero sirve Contiene pos N° Por metro Fe de erratas
	Changements sans préavis	Mejoras constructivas sin previo aviso