

Spare Parts List
Ersatzteilliste
Liste de pièces détachées
Lista de piezas de repuesto

2009-03



TM-92.14 (2009)

TM-92.14 H (2009)

TM-92.14 H2 (2009)

DOLMAR



A member of the *Makita* Group

TM-92.14_H_H2 (2009) (D, GB, F, E)

TM-92.14 (2009), TM-92.14 H
(2009), TM-92.14 H2 (2009)

1

RAHMENSATZ
CHASSIS
CHASSIS
CHASSIS

DOLMAR



A member of the *Trakita* Group

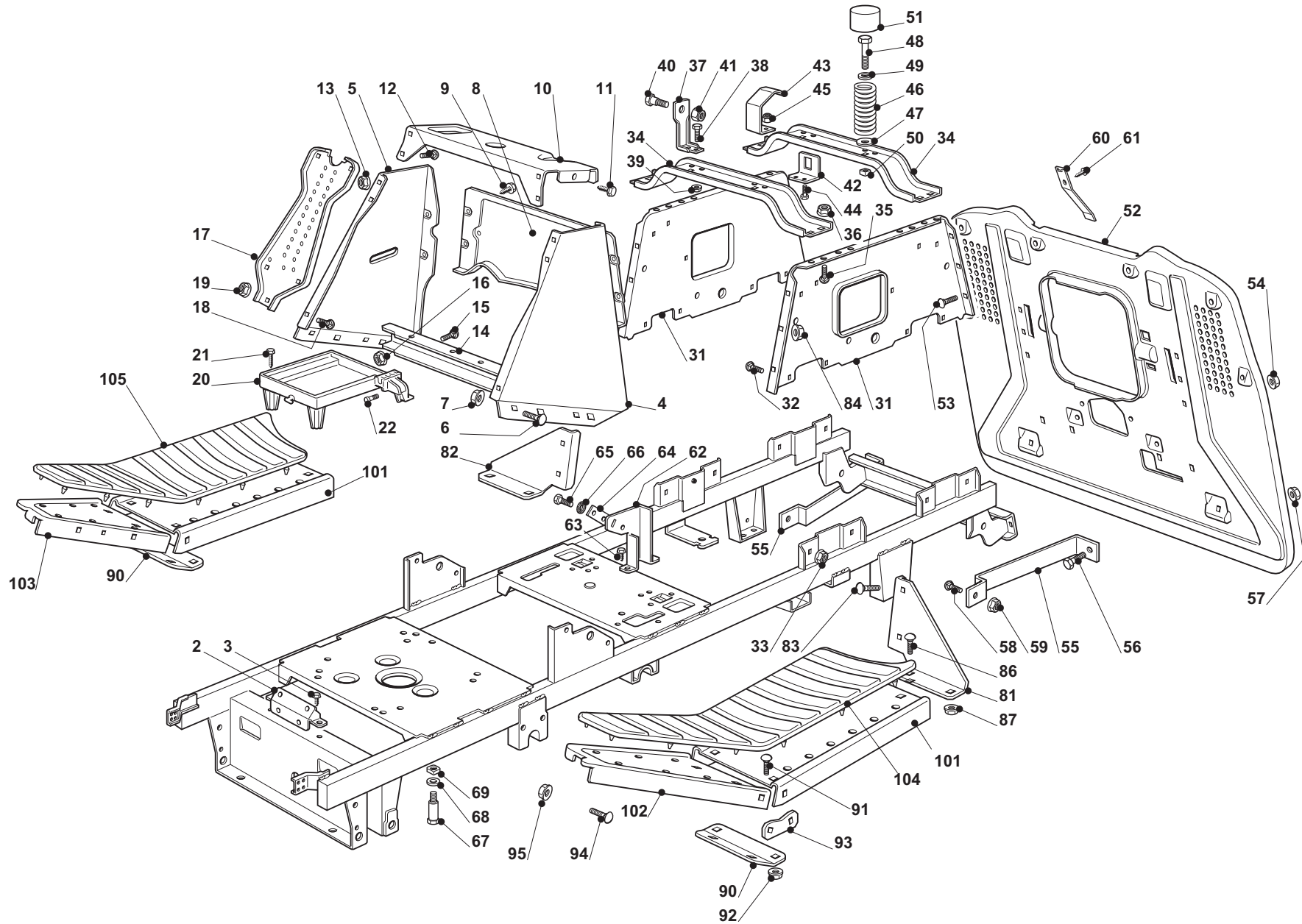

TM-92.14 (2009), TM-92.14 H
(2009), TM-92.14 H2 (2009)

1

RAHMENSATZ
CHASSIS
CHASSIS
CHASSIS

DOLMAR
A member of the **Takita** Group

| Seite / Page | Pos. | TM-92.14 (2009) | TM-92.14 H (2009) | TM-92.14 H2 (2009) | Teil-Nr. Part No. No. de pièce No. de pieza | Hinweise Notes Renseign. Nota | Bezeichnung | Spezifikation Specification | Description | Désignation | Denominación |
|--------------|------|-----------------|-------------------|--------------------|--|--|-----------------------|--------------------------------|----------------------|-------------------------|--------------------|
| 1 | 2 | 1 | 1 | 1 | 664 774 253 | | HALTER | | CLAMP | ETRIER | SOPORTE |
| 1 | 3 | 4 | 4 | 4 | 664 735 121 | | SCHRAUBE | | SCREW | VIS | TORNILLO |
| 1 | 4 | 1 | 1 | 1 | 664 999 243 | | KONSOLENHALTER LINKS | | SUPPORT | SUPPORT | SOPORTE |
| 1 | 5 | 1 | 1 | 1 | 664 785 245 | | KONSOLENHALTER RECHTS | | SUPPORT | SUPPORT | SOPORTE |
| 1 | 6 | 4 | 4 | 4 | 664 818 690 | | SCHRAUBE | | SCREW | VIS | TORNILLO |
| 1 | 7 | 4 | 4 | 4 | 664 293 201 | | MUTTER | | NUT | ECROU | TUERCA |
| 1 | 8 | 1 | 1 | 1 | 664 999 151 | | KONSOLE HINTERRAD | | REAR DASHBOARD SUPP | SUPPORT TABLEAU ARRIERE | SOPORTE |
| 1 | 9 | 4 | 4 | 4 | 664 735 110 | | SCHRAUBE | | SCREW | VIS | TORNILLO |
| 1 | 10 | 1 | 1 | 1 | 664 785 255 | | HALTER | | SUPPORT | SUPPORT | SOPORTE |
| 1 | 11 | 2 | 2 | 2 | 664 735 110 | | SCHRAUBE | | SCREW | VIS | TORNILLO |
| 1 | 12 | 4 | 4 | 4 | 664 815 200 | | SCHRAUBE | | SCREW | VIS | TORNILLO |
| 1 | 13 | 4 | 4 | 4 | 664 292 102 | | MUTTER | | NUT | ECROU | TUERCA |
| 1 | 14 | 1 | 1 | 1 | 664 785 241 | | HALTER | | SUPPORT | SUPPORT | SOPORTE |
| 1 | 15 | 2 | 2 | 2 | 664 815 200 | | SCHRAUBE | | SCREW | VIS | TORNILLO |
| 1 | 16 | 2 | 2 | 2 | 664 292 102 | | MUTTER | | NUT | ECROU | TUERCA |
| 1 | 17 | 2 | 2 | 2 | 664 785 153 | | KONSOLE VORDERRAD | | FRONT DASHBOARD SUPP | SUPPORT TABLEAU AVANT | SOPORTE |
| 1 | 18 | 2 | 2 | 2 | 664 815 200 | | SCHRAUBE | | SCREW | VIS | TORNILLO |
| 1 | 19 | 2 | 2 | 2 | 664 292 102 | | MUTTER | | NUT | ECROU | TUERCA |
| 1 | 20 | 1 | 1 | 1 | 664 785 279 | | BATTERIEHALTER | | BATTERY SUPPORT | SUPPORT BATTERIE | SOPORTE DE BATERÍA |
| 1 | 21 | 4 | 4 | 4 | 664 760 490 | | SCHRAUBE | | SCREW | VIS | TORNILLO |
| 1 | 22 | 1 | 1 | 1 | 664 510 099 | | BOLZEN | | PIN | PIVOT | PIVOTE |
| 1 | 31 | 2 | 2 | 2 | 664 785 249 | | SITZHALTER | | SUPPORT | SUPPORT | SOPORTE |
| 1 | 32 | 8 | 8 | 8 | 664 815 200 | | SCHRAUBE | | SCREW | VIS | TORNILLO |
| 1 | 33 | 8 | 8 | 8 | 664 292 102 | | MUTTER | | NUT | ECROU | TUERCA |
| 1 | 34 | 2 | 2 | 2 | 664 785 257 | | SITZHALTER | | SUPPORT | SUPPORT | SOPORTE |
| 1 | 35 | 8 | 8 | 8 | 664 818 690 | | SCHRAUBE | | SCREW | VIS | TORNILLO |
| 1 | 36 | 8 | 8 | 8 | 664 293 201 | | MUTTER | | NUT | ECROU | TUERCA |
| 1 | 37 | 2 | 2 | 2 | 664 755 039 | | WINKEL | | BRACKET | SUPPORT | SOPORTE |
| 1 | 38 | 4 | 4 | 4 | 664 792 611 | | SCHRAUBE | | SCREW | VIS | TORNILLO |
| 1 | 39 | 4 | 4 | 4 | 664 293 201 | | MUTTER | | NUT | ECROU | TUERCA |
| 1 | 40 | 2 | 2 | 2 | 664 524 970 | | BOLZEN | | PIN | PIVOT | PIVOTE |
| 1 | 41 | 2 | 2 | 2 | 664 155 010 | | MUTTER | | NUT | ECROU | TUERCA |
| 1 | 42 | 1 | 1 | 1 | 664 755 043 | | WINKEL | | BRACKET | SUPPORT | SOPORTE |
| 1 | 43 | 1 | 1 | 1 | 664 430 253 | | FEDER | | SPRING | RESSORT | MUELLE |
| 1 | 44 | 2 | 2 | 2 | 664 789 000 | | SCHRAUBE | | SCREW | VIS | TORNILLO |
| 1 | 45 | 2 | 2 | 2 | 664 154 330 | | MUTTER | | NUT | ECROU | TUERCA |
| 1 | 46 | 2 | 2 | 2 | 664 430 257 | | FEDER | | SPRING | RESSORT | MUELLE |
| 1 | 47 | 2 | 2 | 2 | 664 523 070 | | SCHEIBE | | WASHER | RONDELLE | ARANDELA |
| 1 | 48 | 2 | 2 | 2 | 664 760 515 | | SCHRAUBE | | SCREW | VIS | TORNILLO |
| 1 | 49 | 2 | 2 | 2 | 664 671 653 | | SCHEIBE | | WASHER | RONDELLE | ARANDELA |
| 1 | 50 | 2 | 2 | 2 | 664 360 425 | | MUTTER | | NUT | ECROU | TUERCA |
| 1 | 51 | 2 | 2 | 2 | 664 122 000 | | SCHUTZKASTEN | | HOOD | PROTECTEUR | CUBIERTA |

TM-92.14 (2009), TM-92.14 H
(2009), TM-92.14 H2 (2009)

1

RAHMENSATZ
CHASSIS
CHASSIS
CHASSIS

DOLMAR



A member of the *Trakita* Group

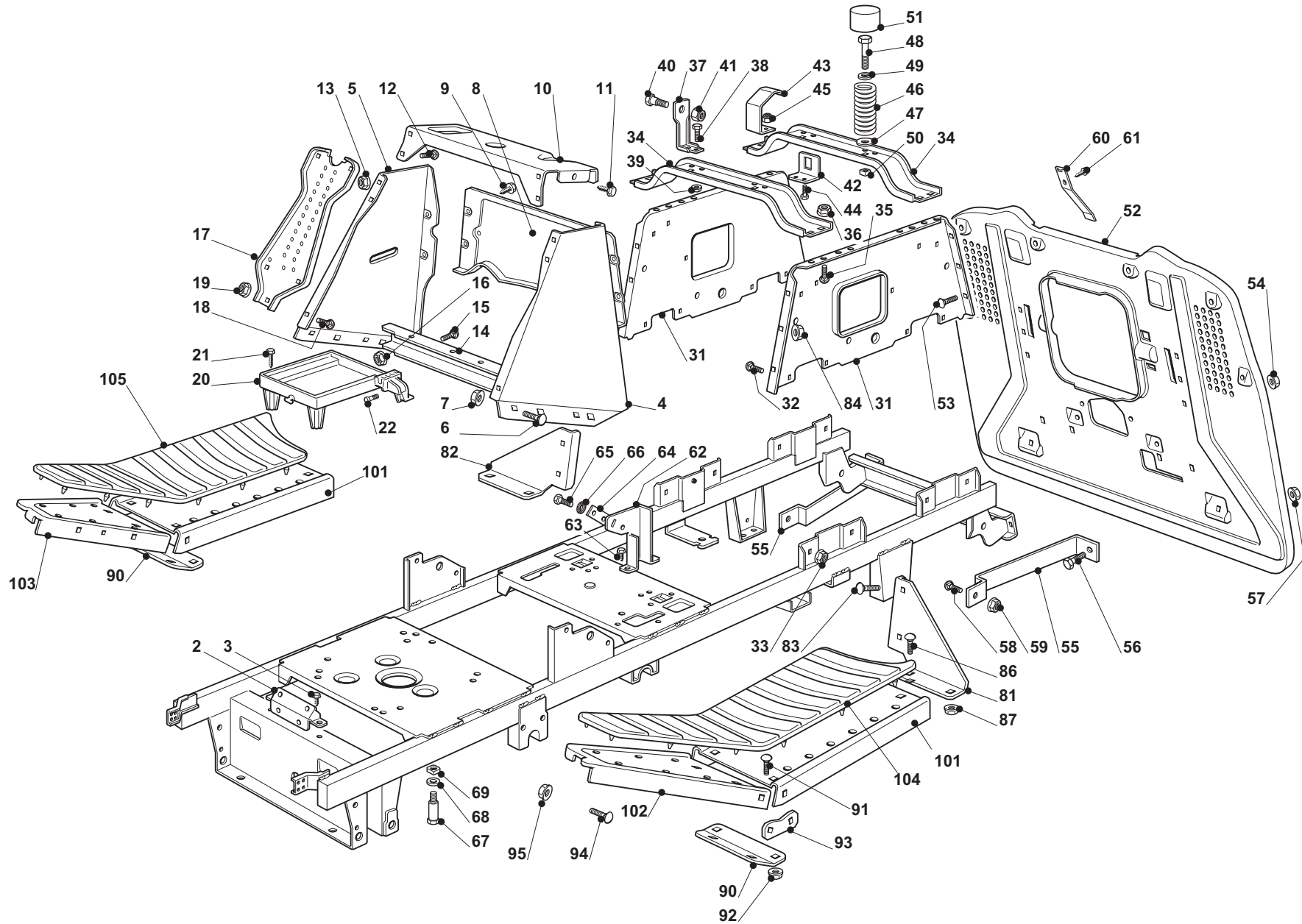

TM-92.14 (2009), TM-92.14 H
(2009), TM-92.14 H2 (2009)

1

RAHMENSATZ
CHASSIS
CHASSIS
CHASIS

DOLMAR
A member of the **Takita** Group

| Seite / Page | Pos. | TM-92.14 (2009) | TM-92.14 H (2009) | TM-92.14 H2 (2009) | Teil-Nr. Part No. No. de pièce No. de pieza | Hinweise Notes Renseign. Nota | Bezeichnung | Spezifikation Specification | Description | Désignation | Denominación |
|--------------|------|-----------------|-------------------|--------------------|--|--|------------------------|--------------------------------|-----------------------|------------------------|------------------------|
| 1 | 52 | 1 | 1 | 1 | 664 947 041 | | PLATTE | | PLATE | PLAQUE | PLACA |
| 1 | 53 | 6 | 6 | 6 | 664 792 611 | | SCHRAUBE | | SCREW | VIS | TORNILLO |
| 1 | 54 | 6 | 6 | 6 | 664 293 201 | | MUTTER | | NUT | ECROU | TUERCA |
| 1 | 55 | 2 | 2 | 2 | 664 650 119 | | PLATTE | | PLATE | PLAQUE | PLACA |
| 1 | 56 | 2 | 2 | 2 | 664 792 611 | | SCHRAUBE | | SCREW | VIS | TORNILLO |
| 1 | 57 | 2 | 2 | 2 | 664 293 201 | | MUTTER | | NUT | ECROU | TUERCA |
| 1 | 58 | 2 | 2 | 2 | 664 818 690 | | SCHRAUBE | | SCREW | VIS | TORNILLO |
| 1 | 59 | 2 | 2 | 2 | 664 293 201 | | MUTTER | | NUT | ECROU | TUERCA |
| 1 | 60 | 1 | 1 | 1 | 664 430 554 | | FEDER | | SPRING | RESSORT | MUELLE |
| 1 | 61 | 1 | 1 | 1 | 664 735 110 | | SCHRAUBE | | SCREW | VIS | TORNILLO |
| 1 | 62 | 1 | 1 | 1 | 664 785 141 | | HALTER | | SUPPORT | SUPPORT | SOPORTE |
| 1 | 63 | 2 | 2 | 2 | 664 735 110 | | SCHRAUBE | | SCREW | VIS | TORNILLO |
| 1 | 64 | | 1 | 1 | 664 546 019 | | PLATTE | | PLATE | PLAQUE | PLACA |
| 1 | 65 | | 2 | 2 | 664 735 602 | | SCHRAUBE | | SCREW | VIS | TORNILLO |
| 1 | 66 | | 2 | 2 | 664 581 100 | | FEDERRING | | SPRING RING | BAGUE À RESSORT | ARANDELA ELÁSTICA |
| 1 | 67 | 2 | | | 664 580 030 | | RIEMENFÜHRUNG | | BELT GUIDE | GUIDE DE COURROIRE | GUÍA DE LA CORREA |
| 1 | 68 | 2 | | | 664 523 060 | | SCHEIBE | | WASHER | RONDELLE | ARANDELA |
| 1 | 69 | 2 | | | 664 360 425 | | MUTTER | | NUT | ECROU | TUERCA |
| 1 | 81 | 1 | 1 | 1 | 664 774 371 | | HALTER | | SUPPORT | SUPPORT | SOPORTE |
| 1 | 82 | 1 | 1 | 1 | 664 774 369 | | HALTER | | SUPPORT | SUPPORT | SOPORTE |
| 1 | 83 | 4 | 4 | 4 | 664 792 611 | | SCHRAUBE | | SCREW | VIS | TORNILLO |
| 1 | 84 | 4 | 4 | 4 | 664 293 201 | | MUTTER | | NUT | ECROU | TUERCA |
| 1 | 86 | 4 | 4 | 4 | 664 818 690 | | SCHRAUBE | | SCREW | VIS | TORNILLO |
| 1 | 87 | 4 | 4 | 4 | 664 292 102 | | MUTTER | | NUT | ECROU | TUERCA |
| 1 | 90 | 2 | 2 | 2 | 664 774 375 | | HALTER | | BRACKET | ETRIER | SOPORTE |
| 1 | 91 | 12 | 12 | 12 | 664 815 205 | | SCHRAUBE | | SCREW | VIS | TORNILLO |
| 1 | 92 | 12 | 12 | 12 | 664 293 102 | | MUTTER | | NUT | ECROU | TUERCA |
| 1 | 93 | 2 | 2 | 2 | 664 774 351 | | HALTER | | BRACKET | ETRIER | SOPORTE |
| 1 | 94 | 4 | 4 | 4 | 664 815 200 | | SCHRAUBE | | SCREW | VIS | TORNILLO |
| 1 | 95 | 4 | 4 | 4 | 664 293 102 | | MUTTER | | NUT | ECROU | TUERCA |
| 1 | 101 | 2 | 2 | 2 | 664 500 029 | | FUSSBRETTHALTER RECHTS | | SUPPORT | SUPPORT | SOPORTE |
| 1 | 102 | 1 | 1 | 1 | 664 500 027 | | FUSSBRETTHALTER LINKS | | SUPPORT | SUPPORT | SOPORTE |
| 1 | 103 | 1 | 1 | 1 | 664 500 025 | | FUSSBRETTHALTER RECHTS | | SUPPORT | SUPPORT | SOPORTE |
| 1 | 104 | 1 | 1 | 1 | 664 110 327 | | FUSSBRETTDECKEL RECHTS | | RIGHT FOOTBOARD COVER | COUVRE MARCHEPIED DRO. | TAPA APOYAPIES DER. |
| 1 | 105 | 1 | 1 | 1 | 664 110 326 | | FUSSBRETTDECKEL LINKS | | LEFT FOOTBOARD COVER | COUVRE MARCHEPIED GAU. | CUBIERTA APOYAPIES IZ. |

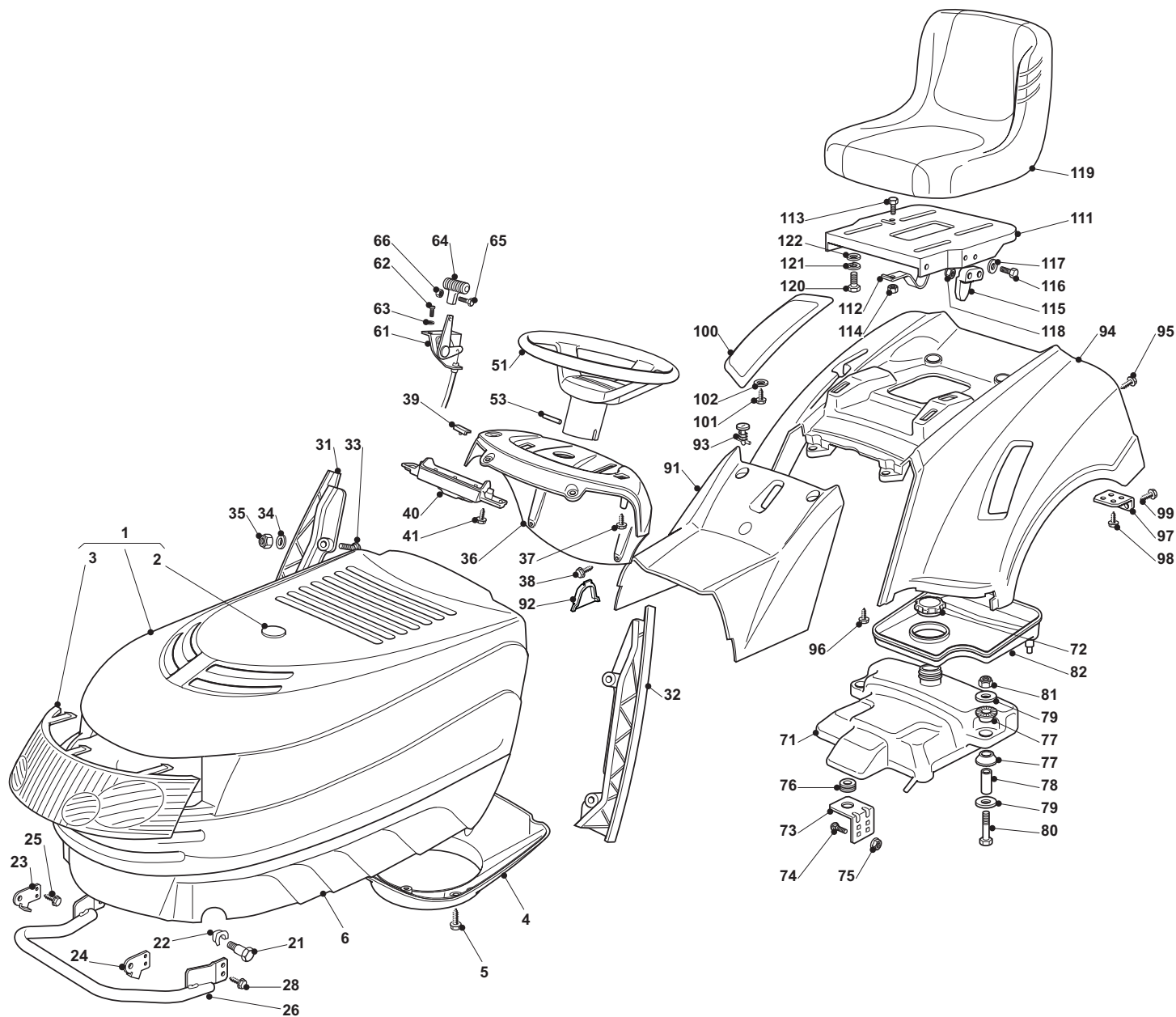

TM-92.14 (2009), TM-92.14 H
(2009), TM-92.14 H2 (2009)

2

KARROSSERIE
BODY
CARROSSERIE
CARROCERÍA

DOLMAR
A member of the **Takata** Group

| Seite / Page | Pos. | TM-92.14 (2009) | TM-92.14 H (2009) | TM-92.14 H2 (2009) | Teil-Nr. Part No. No. de pièce No. de pieza | Hinweise Notes Renseign. Nota | Bezeichnung | Spezifikation Specification | Description | Désignation | Denominación |
|--------------|------|-----------------|-------------------|--------------------|--|--|------------------------|--------------------------------|-----------------------|------------------------|--------------------|
| 2 | 1 | 1 | 1 | 1 | 664 076 938 | | OBERHAUBE | | HOOD | CAPOT | CUBIERTA |
| 2 | 2 | 1 | 1 | 1 | 664 547 103 | | PLATTE | | PLATE | PLAQUE | PLACA |
| 2 | 3 | 1 | 1 | 1 | 664 410 859 | | FRONTTEIL | | GRILL | PANNEAU | FRONTAL CUBIERTA |
| 2 | 4 | 1 | 1 | 1 | 664 108 024 | | AUSWURFKANAL | | CONVEYOR | CONVOYEUR | JUEGO DE CHAPA |
| 2 | 5 | 3 | 3 | 3 | 664 728 686 | | SCHRAUBE | | SCREW | VIS | TORNILLO |
| 2 | 6 | 1 | 1 | 1 | 664 076 808 | | UNTERHAUBE | | HOOD | CAPOT | CUBIERTA |
| 2 | 21 | 2 | 2 | 2 | 664 510 045 | | BOLZEN | | BOLT | BOULON | BULÓN |
| 2 | 22 | 2 | 2 | 2 | 664 436 050 | | PLATTE | | PLATE | PLAQUE | PLACA |
| 2 | 23 | 1 | 1 | 1 | 664 547 089 | | PLATTE RECHTS | | PLATE | PLAQUE | PLACA |
| 2 | 24 | 1 | 1 | 1 | 664 547 091 | | PLATTE LINKS | | PLATE | PLAQUE | PLACA |
| 2 | 25 | 4 | 4 | 4 | 664 731 580 | | SCHRAUBE | | SCREW | VIS | TORNILLO |
| 2 | 26 | 1 | 1 | 1 | 664 999 031 | | AUSPUFFSCHUTZ | | GUARD | PROTECTION | PROTECCIÓN |
| 2 | 28 | 4 | 4 | 4 | 664 734 995 | | SCHRAUBE | | SCREW | VIS | TORNILLO |
| 2 | 31 | 1 | 1 | 1 | 664 599 010 | | RECHTER KONSOLENHALTER | | RIGHT DASHBOARD SUPP. | SUPPORT TABLEAU DROITE | SOPORTE |
| 2 | 32 | 1 | 1 | 1 | 664 599 011 | | LINKER KONSOLENHALTER | | LEFT DASHBOARD SUPP. | SUPPORT TABLEAU GAUCHE | SOPORTE |
| 2 | 33 | 4 | 4 | 4 | 664 815 221 | | SCHRAUBE | | SCREW | VIS | TORNILLO |
| 2 | 34 | 4 | 4 | 4 | 664 521 330 | | SCHEIBE | | WASHER | RONDELLE | ARANDELA |
| 2 | 35 | 4 | 4 | 4 | 664 154 510 | | MUTTER | | NUT | ECROU | TUERCA |
| 2 | 36 | 1 | 1 | 1 | 664 120 190 | | KONSOLE | | DASH BOARD | CONSOLE | CONSOLA |
| 2 | 37 | 2 | 2 | 2 | 664 728 440 | | SCHRAUBE | | SCREW | VIS | TORNILLO |
| 2 | 38 | 2 | 2 | 2 | 664 735 402 | | SCHRAUBE | | SCREW | VIS | TORNILLO |
| 2 | 39 | 2 | 2 | 2 | 664 260 000 | | GUMMISTOPFEN | | GROMMET | BOUCHON | TAPÓN |
| 2 | 40 | 1 | 1 | 1 | 664 600 074 | | SCHUTZ | | PROTECTION | PROTECTION | PROTECCIÓN |
| 2 | 41 | 2 | 2 | 2 | 664 735 402 | | SCHRAUBE | | SCREW | VIS | TORNILLO |
| 2 | 51 | 1 | 1 | 1 | 664 961 216 | | LENKRAD | | STEERING WHEEL | VOLANT | VOLANTE |
| 2 | 53 | 1 | 1 | 1 | 664 620 299 | | STIFT | | PIN | GOUILLE | PASADOR |
| 2 | 61 | 1 | 1 | 1 | 664 000 200 | | GASZUG | | BOWDEN CABLE | CÂBLE BOWDEN | TRACCIÓN BOWDEN |
| 2 | 62 | 2 | 2 | 2 | 664 788 512 | | SCHRAUBE | | SCREW | VIS | TORNILLO |
| 2 | 63 | 2 | 2 | 2 | 664 581 200 | | FEDERRING | | GROWER | GROWER | ARANDELA ELÁSTICA |
| 2 | 64 | 1 | 1 | 1 | 664 394 501 | | GRIFF | | HANDLE | POIGNEE | MANETA |
| 2 | 65 | 1 | 1 | 1 | 664 726 399 | | SCHRAUBE | | SCREW | VIS | TORNILLO |
| 2 | 66 | 1 | 1 | 1 | 664 290 800 | | MUTTER | | NUT | ECROU | TUERCA |
| 2 | 71 | 1 | 1 | 1 | 664 735 123 | | TANK | | TANK | RESERVOIR | DEPÓSITO |
| 2 | 72 | 1 | 1 | 1 | 664 795 001 | | TANKVERSCHLUSS | | CAP | BOUCHON | TAPÓN DEL DEPÓSITO |
| 2 | 73 | 1 | 1 | 1 | 664 785 259 | | HALTER | | SUPPORT | SUPPORT | SOPORTE |
| 2 | 74 | 2 | 2 | 2 | 664 815 200 | | SCHRAUBE | | SCREW | VIS | TORNILLO |
| 2 | 75 | 2 | 2 | 2 | 664 292 102 | | MUTTER | | NUT | ECROU | TUERCA |
| 2 | 76 | 1 | 1 | 1 | 664 564 522 | | SCHUTZ | | PROTECTION | PROTECTION | PROTECCIÓN |
| 2 | 77 | 4 | 4 | 4 | 664 712 001 | | SCHUTZ | | PROTECTION | PROTECTION | PROTECCIÓN |
| 2 | 78 | 2 | 2 | 2 | 664 040 625 | | BUCHSE | | BUSH | DOUILLE | CASQUILLO |
| 2 | 79 | 4 | 4 | 4 | 664 523 070 | | SCHEIBE | | WASHER | RONDELLE | ARANDELA |
| 2 | 80 | 2 | 2 | 2 | 664 691 400 | | SCHRAUBE | | SCREW | VIS | TORNILLO |

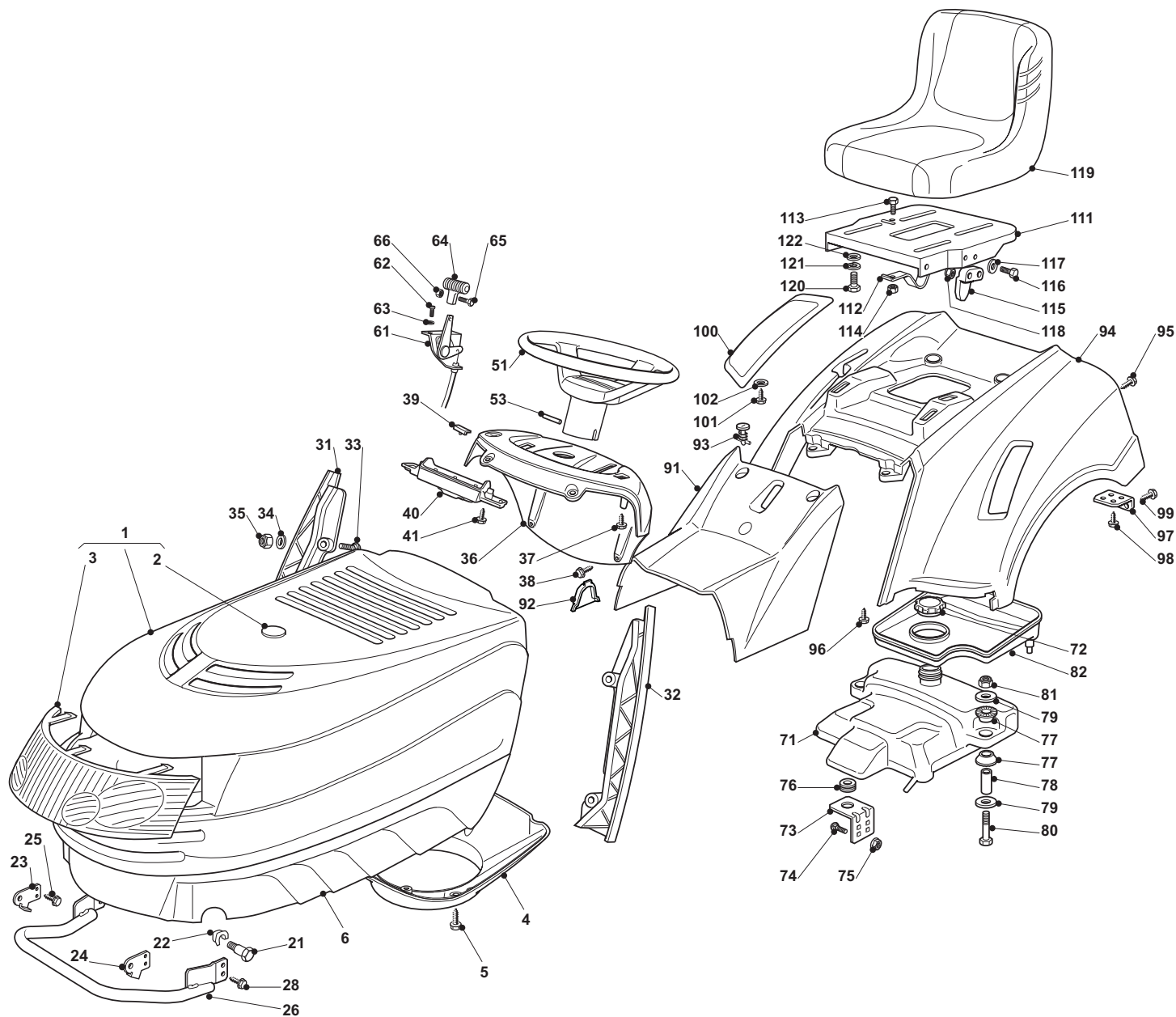

TM-92.14 (2009), TM-92.14 H
(2009), TM-92.14 H2 (2009)

2

KARROSSERIE
BODY
CARROSSERIE
CARROCERÍA

DOLMAR
A member of the **Takita** Group

| Seite / Page | Pos. | TM-92.14 (2009) | TM-92.14 H (2009) | TM-92.14 H2 (2009) | Teil-Nr. Part No. No. de pièce No. de pieza | Hinweise Notes Renseign. Nota | Bezeichnung | Spezifikation Specification | Description | Désignation | Denominación |
|--------------|------|-----------------|-------------------|--------------------|--|--|-------------------|--------------------------------|-------------|------------------|-------------------|
| 2 | 81 | 2 | 2 | 2 | 664 155 000 | | MUTTER | | NUT | ECROU | TUERCA |
| 2 | 82 | 1 | 1 | 1 | 664 600 073 | | SCHUTZ | | PROTECTION | PROTECTION | PROTECCIÓN |
| 2 | 91 | 1 | 1 | 1 | 664 110 330 | | ABDECKUNG, ROT | | CAP, RED | CAPUCHON, ROUGE | TAPA, COLORADA |
| 2 | 92 | 1 | | | 664 207 172 | | PLATTE | | PLATE | PLAQUE | PLACA |
| 2 | 93 | 2 | 2 | 2 | 664 580 020 | | STIFT | | PIN | GOUILLE | PASADOR |
| 2 | 94 | 1 | 1 | 1 | 664 110 329 | | RADABDECKUNG, ROT | | COVER, RED | COUVERCLE, ROUGE | CONSOLA, COLORADA |
| 2 | 95 | 4 | 4 | 4 | 664 735 402 | | SCHRAUBE | | SCREW | VIS | TORNILLO |
| 2 | 96 | 2 | 2 | 2 | 664 735 402 | | SCHRAUBE | | SCREW | VIS | TORNILLO |
| 2 | 97 | 2 | 2 | 2 | 664 755 041 | | WINKEL | | BRACKET | SUPPORT | SOPORTE |
| 2 | 98 | 4 | 4 | 4 | 664 728 686 | | SCHRAUBE | | SCREW | VIS | TORNILLO |
| 2 | 99 | 2 | 2 | 2 | 664 735 110 | | SCHRAUBE | | SCREW | VIS | TORNILLO |
| 2 | 100 | | 1 | 1 | 664 207 171 | | KAPPE | | CAP | CAPUCHON | TAPA |
| 2 | 101 | | 2 | 2 | 664 735 402 | | SCHRAUBE | | SCREW | VIS | TORNILLO |
| 2 | 102 | | 4 | 4 | 664 523 050 | | SCHEIBE | | WASHER | RONDELLE | ARANDELA |
| 2 | 111 | 1 | 1 | 1 | 664 547 033 | | PLATTE | | PLATE | PLAQUE | PLACA |
| 2 | 112 | 1 | 1 | 1 | 664 430 223 | | FEDER | | SPRING | RESSORT | MUELLE |
| 2 | 113 | 1 | 1 | 1 | 664 789 000 | | SCHRAUBE | | SCREW | VIS | TORNILLO |
| 2 | 114 | 1 | 1 | 1 | 664 154 330 | | MUTTER | | NUT | ECROU | TUERCA |
| 2 | 115 | 1 | 1 | 1 | 664 063 021 | | NOCKEN | | CAM | CAME | LEVA |
| 2 | 116 | 2 | 2 | 2 | 664 789 100 | | SCHRAUBE | | SCREW | VIS | TORNILLO |
| 2 | 117 | 2 | 2 | 2 | 664 523 020 | | SCHEIBE | | WASHER | RONDELLE | ARANDELA |
| 2 | 118 | 2 | 2 | 2 | 664 154 330 | | MUTTER | | NUT | ECROU | TUERCA |
| 2 | 119 | 1 | 1 | 1 | 664 722 463 | | SITZ | | SEAT | SIEGE | ASIENTO |
| 2 | 120 | 4 | 4 | 4 | 664 793 101 | | SCHRAUBE | | SCREW | VIS | TORNILLO |
| 2 | 121 | 4 | 4 | 4 | 664 583 500 | | FEDERRING | | GROWER | GROWER | ARANDELA ELÁSTICA |
| 2 | 122 | 4 | 4 | 4 | 664 523 060 | | SCHEIBE | | WASHER | RONDELLE | ARANDELA |

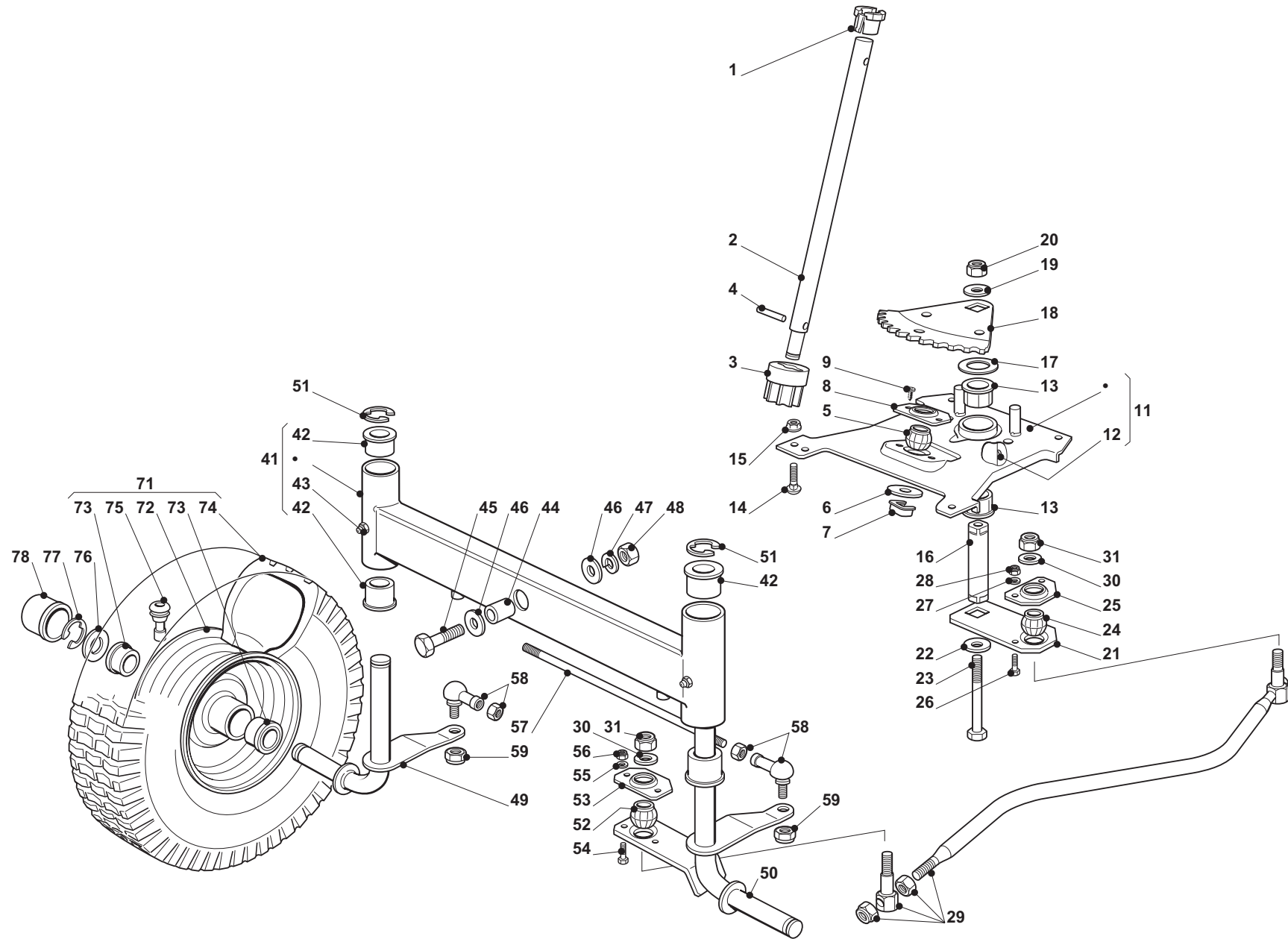

TM-92.14 (2009), TM-92.14 H
(2009), TM-92.14 H2 (2009)

3a

LENKGETRIEBE
STEERING
BARRE DE DIRECTION
BARRA DE DIRECCIÓN

DOLMAR
A member of the **Takita** Group

| Seite / Page | Pos. | TM-92.14 (2009) | TM-92.14 H (2009) | TM-92.14 H2 (2009) | Teil-Nr. Part No. No. de pièce No. de pieza | Hinweise Notes Renseign. Nota | Bezeichnung | Spezifikation Specification | Description | Désignation | Denominación |
|--------------|------|-----------------|-------------------|--------------------|--|--|---------------------|--------------------------------|------------------|----------------------|----------------------|
| 3a | 1 | 1 | 1 | 1 | 664 038 004 | | BUCHSE | | BUSH | DOUILLE | CASQUILLO |
| 3a | 2 | 1 | 1 | 1 | 664 520 006 | | LENKSÄULE | | STEERING COLUMN | COLONNE DE DIRECTION | COLUMN DE DIRECCIÓN |
| 3a | 3 | 1 | 1 | 1 | 664 570 050 | | RITZEL | | PINION | PIGNON | PIÑÓN |
| 3a | 4 | 1 | 1 | 1 | 664 622 650 | | STIFT | | PIN | GOUPILLE | PASADOR |
| 3a | 5 | 1 | 1 | 1 | 664 743 000 | | GELENK | | JOINT | JOINT | ARTICULACIÓN |
| 3a | 6 | 1 | 1 | 1 | 664 521 370 | | SCHEIBE | | WASHER | RONDELLE | ARANDELA |
| 3a | 7 | 1 | 1 | 1 | 664 436 030 | | PLÄTTCHEN | | PLATE | PLAQUETTE | PLAQUITA |
| 3a | 8 | 1 | 1 | 1 | 664 785 213 | | HALTER | | SUPPORT | SUPPORT | SOPORTE |
| 3a | 9 | 2 | 2 | 2 | 664 729 601 | | SCHRAUBE | | SCREW | VIS | TORNILLO |
| 3a | 11 | 1 | 1 | 1 | 664 547 045 | | HALTER | | SUPPORT | SUPPORT | SOPORTE |
| 3a | 12 | 1 | 1 | 1 | 664 379 511 | | FETTBUCHSE | | GREASE DISPENSER | GRAISSEUR | CASQUILLO DE ENGRASE |
| 3a | 13 | 2 | 2 | 2 | 664 040 624 | | BUCHSE | | BUSH | DOUILLE | CASQUILLO |
| 3a | 14 | 4 | 4 | 4 | 664 815 200 | | SCHRAUBE | | SCREW | VIS | TORNILLO |
| 3a | 15 | 4 | 4 | 4 | 664 292 102 | | MUTTER | | NUT | ECROU | TUERCA |
| 3a | 16 | 1 | 1 | 1 | 664 510 092 | | BOLZEN | | PIN | PIVOT | PIVOTE |
| 3a | 17 | 1 | 1 | 1 | 664 670 019 | | SCHEIBE | | WASHER | RONDELLE | ARANDELA |
| 3a | 18 | 1 | 1 | 1 | 664 735 513 | | LENKWELLE | | STEERING SHAFT | ARBRE DIRECTION | ÁRBOL DE DIRECCIÓN |
| 3a | 19 | 1 | 1 | 1 | 664 523 080 | | SCHEIBE | | WASHER | RONDELLE | ARANDELA |
| 3a | 20 | 1 | 1 | 1 | 664 155 020 | | MUTTER | | NUT | ECROU | TUERCA |
| 3a | 21 | 1 | 1 | 1 | 664 318 205 | | HEBEL | | LEVER | LEVIER | PALANCA |
| 3a | 22 | 1 | 1 | 1 | 664 523 080 | | SCHEIBE | | WASHER | RONDELLE | ARANDELA |
| 3a | 23 | 1 | 1 | 1 | 664 794 985 | | SCHRAUBE | | SCREW | VIS | TORNILLO |
| 3a | 24 | 1 | 1 | 1 | 664 743 000 | | GELENK | | JOINT | JOINT | ARTICULACIÓN |
| 3a | 25 | 1 | 1 | 1 | 664 785 213 | | HALTER | | SUPPORT | SUPPORT | SOPORTE |
| 3a | 26 | 2 | 2 | 2 | 664 791 213 | | SCHRAUBE | | SCREW | VIS | TORNILLO |
| 3a | 27 | 2 | 2 | 2 | 664 521 330 | | SCHEIBE | | WASHER | RONDELLE | ARANDELA |
| 3a | 28 | 2 | 2 | 2 | 664 154 510 | | MUTTER | | NUT | ECROU | TUERCA |
| 3a | 29 | 1 | 1 | 1 | 664 999 539 | | LENKSTAB | | ROD | TIGE | VARILLA |
| 3a | 30 | 2 | 2 | 2 | 664 523 070 | | SCHEIBE | | WASHER | RONDELLE | ARANDELA |
| 3a | 31 | 2 | 2 | 2 | 664 155 010 | | MUTTER | | NUT | ECROU | TUERCA |
| 3a | 41 | 1 | 1 | 1 | 664 034 024 | | KIPPHEBEL KPL. | | EQUALIZER | BALANCIER | PALANCA BASCULANTE |
| 3a | 42 | 4 | 4 | 4 | 664 034 002 | | BUCHSE | | BUSH | DOUILLE | CASQUILLO |
| 3a | 43 | 2 | 2 | 2 | 664 379 511 | | FETTBUCHSE | | GREASE DISPENSER | GRAISSEUR | CASQUILLO DE ENGRASE |
| 3a | 44 | 1 | 1 | 1 | 664 160 016 | | DISTANZRING | | SPACER | ENTRETOISE | DISTANCIADOR |
| 3a | 45 | 1 | 1 | 1 | 664 692 695 | | SCHRAUBE | | SCREW | VIS | TORNILLO |
| 3a | 46 | 2 | 2 | 2 | 664 523 100 | | SCHEIBE | | WASHER | RONDELLE | ARANDELA |
| 3a | 47 | 1 | 1 | 1 | 664 587 100 | | FEDERRING | | GROWER | GROWER | ARANDELA ELÁSTICA |
| 3a | 48 | 1 | 1 | 1 | 664 295 300 | | MUTTER | | NUT | ECROU | TUERCA |
| 3a | 49 | 1 | 1 | 1 | 664 230 363 | | ACHSSCHENKEL RECHTS | | STUB AXLE RIGHT | FUSEAU DROITE | MANGUETA DERECHA |
| 3a | 50 | 1 | 1 | 1 | 664 230 365 | | ACHSSCHENKEL LINKS | | STUB AXLE LEFT | FUSEAU GAUCHE | MANGUETA IZQUIERDA |
| 3a | 51 | 2 | 2 | 2 | 664 001 000 | | SPRENGRING | | SNAP RING | ANNEAU RESSORT | ANILLO DE SUJECIÓN |
| 3a | 52 | 1 | 1 | 1 | 664 743 000 | | GELENK | | JOINT | JOINT | ARTICULACIÓN |

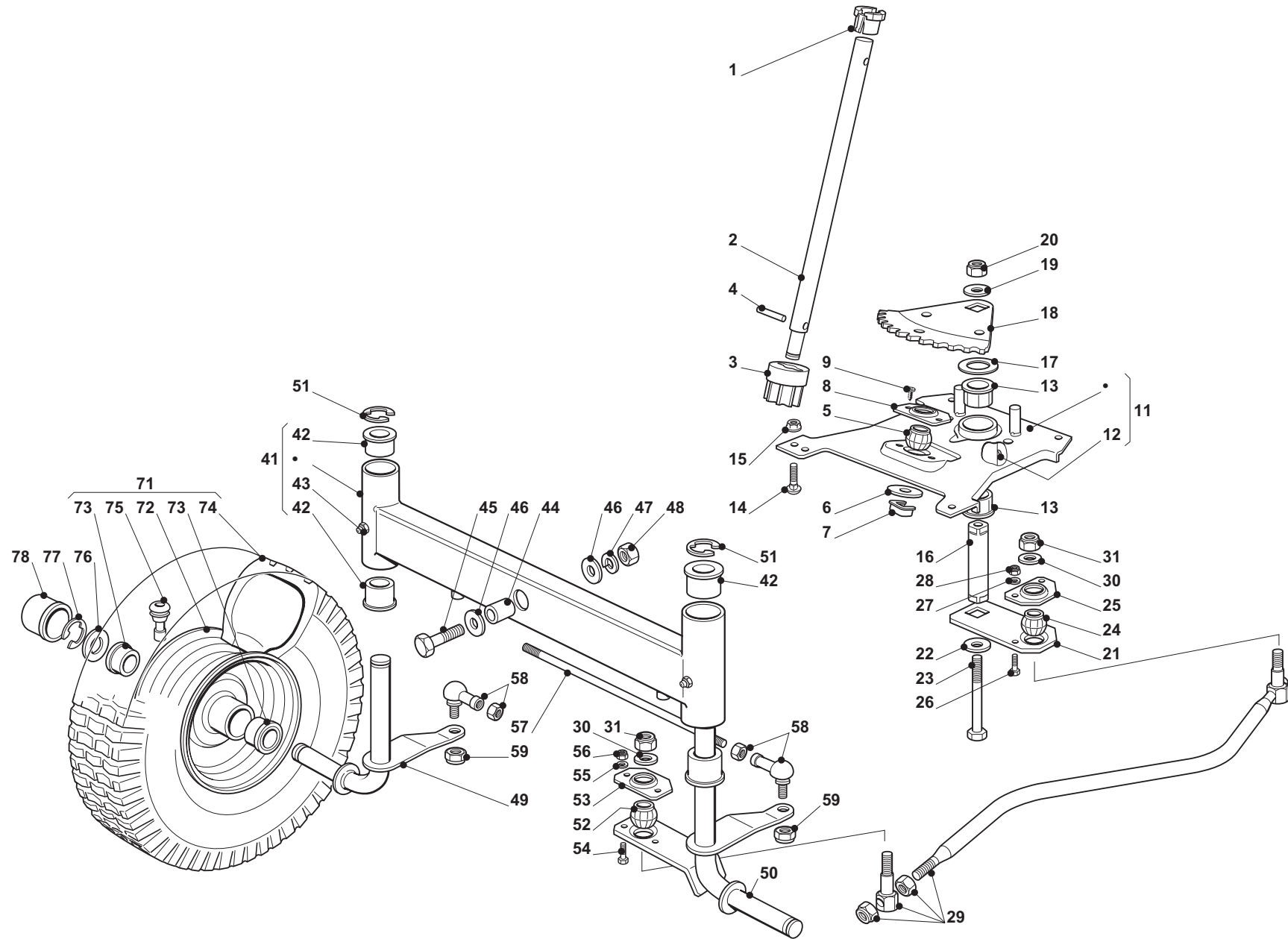

TM-92.14 (2009), TM-92.14 H
(2009), TM-92.14 H2 (2009)

3a

LENKGETRIEBE
STEERING
BARRE DE DIRECTION
BARRA DE DIRECCIÓN

DOLMAR

A member of the **Takita** Group

| Seite / Page | Pos. | TM-92.14 (2009) | TM-92.14 H (2009) | TM-92.14 H2 (2009) | Teil-Nr. Part No. No. de pièce No. de pieza | Hinweise Notes Renseign. Nota | Bezeichnung | Spezifikation Specification | Description | Désignation | Denominación |
|--------------|------|-----------------|-------------------|--------------------|--|--|-----------------|--------------------------------|-------------|----------------|--------------------|
| 3a | 53 | 1 | 1 | 1 | 664 785 213 | | HALTER | | SUPPORT | SUPPORT | SOPORTE |
| 3a | 54 | 2 | 2 | 2 | 664 791 213 | | SCHRAUBE | | SCREW | VIS | TORNILLO |
| 3a | 55 | 2 | 2 | 2 | 664 521 330 | | SCHEIBE | | WASHER | RONDELLE | ARANDELA |
| 3a | 56 | 2 | 2 | 2 | 664 154 510 | | MUTTER | | NUT | ECROU | TUERCA |
| 3a | 57 | 1 | 1 | 1 | 664 840 023 | | SPANNSTANGE | | TIE ROD | TIRANT | SENSOR |
| 3a | 58 | 2 | 2 | 2 | 664 746 600 | | GELENK | | JOINT | JOINT | ARTICULACIÓN |
| 3a | 59 | 2 | 2 | 2 | 664 156 602 | | MUTTER | | NUT | ECROU | TUERCA |
| 3a | 71 | 2 | 2 | 2 | 664 999 007 | | VORDERRAD | | FRONT WHEEL | ROUE AVANT | RUEDA DELANTERA |
| 3a | 72 | 2 | 2 | 2 | 664 999 590 | | VORDERRAD FELGE | | RIMM | JANTE | LLANTA |
| 3a | 73 | 4 | 4 | 4 | 664 122 210 | | LAGER | | BEARING | COUSSINET | RODAMIENTO |
| 3a | 74 | 2 | 2 | 2 | 664 590 051 | | REIFEN | | SHOE | PNEU | NEUMÁTICO |
| 3a | 75 | 2 | 2 | 2 | 664 950 000 | | VENTIL | | VALVE | SOUPAPE | VÁLVULA |
| 3a | 76 | 2 | 2 | 2 | 664 670 005 | | SCHEIBE | | WASHER | RONDELLE | ARANDELA |
| 3a | 77 | 2 | 2 | 2 | 664 001 000 | | SPRENGRING | | SNAP RING | ANNEAU RESSORT | ANILLO DE SUJECIÓN |
| 3a | 78 | 2 | 2 | 2 | 664 110 230 | | NABENDECKEL | | HUB COVER | COUVRE MOYEU | TAPACUBOS |

TM-92.14 (2009), TM-92.14 H
(2009), TM-92.14 H2 (2009)

4m

GETRIEBE UND BREMSE ANTRIEB
DRIVE AND BRAKE CONTROLS
COMMANDE TRANSMISSION ET FREIN
ACCIONAMIENTO TRANSMISSION Y FRENOS

DOLMAR



A member of the **Takita** Group

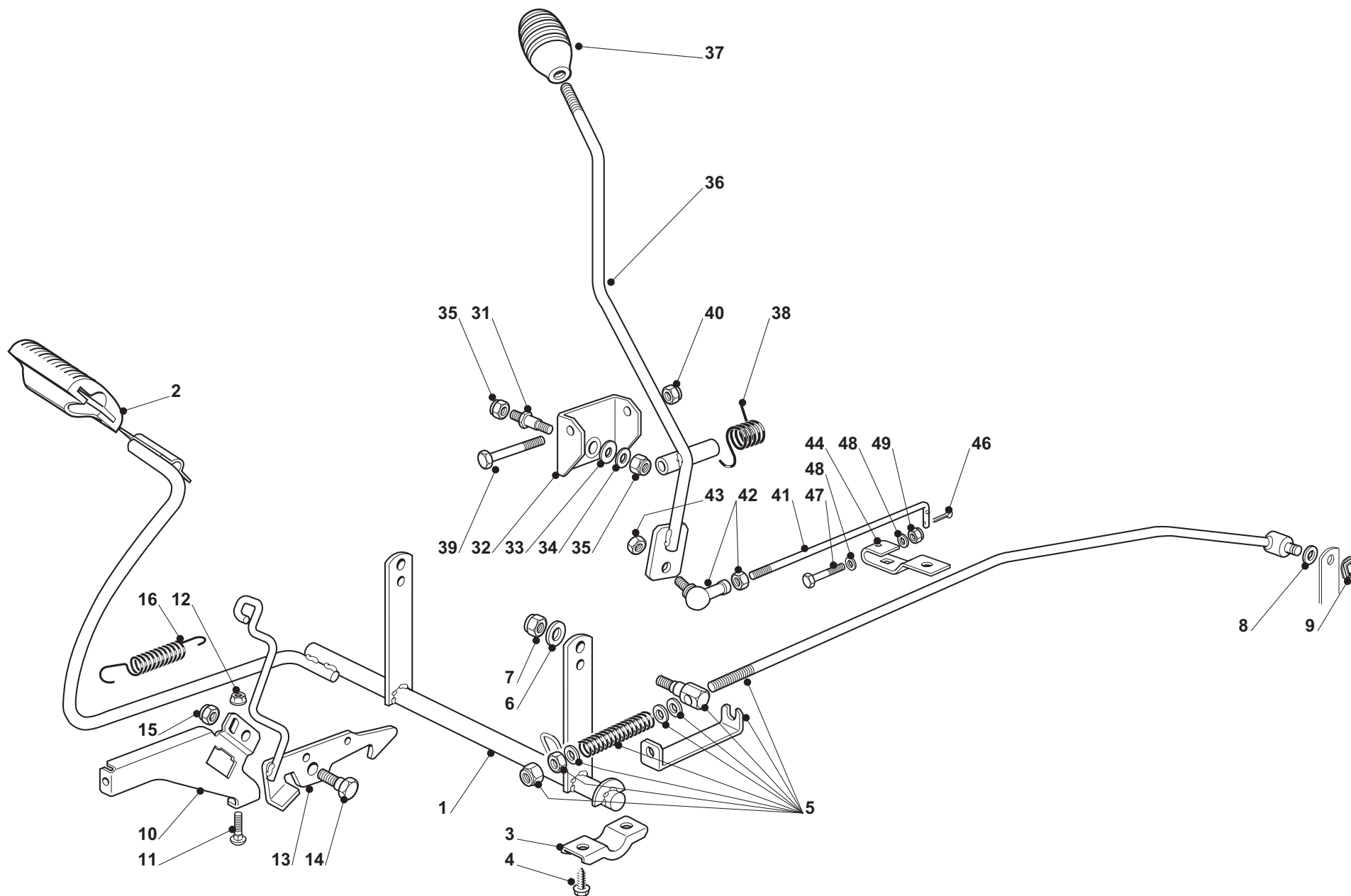

TM-92.14 (2009), TM-92.14 H
(2009), TM-92.14 H2 (2009)

4m

GETRIEBE UND BREMSE ANTRIEB
DRIVE AND BRAKE CONTROLS
COMMANDE TRANSMISSION ET FREIN
ACCIONAMIENTO TRANSMISIÓN Y FRENOS

DOLMAR
A member of the **Takita** Group

| Seite / Page | Pos. | Teil-Nr. Part No. No. de pièce No. de pieza | Hinweise Notes Renseign. Nota | Bezeichnung | Spezifikation Specification | Description | Désignation | Denominación |
|--------------|------|--|--|-------------|--------------------------------|-------------|---------------|----------------|
| 4m | 1 | 664 999 027 | | PEDAL | | PEDAL | PEDAL | PEDAL |
| 4m | 2 | 664 110 269 | | PEDALGUMMI | | PEDAL PAD | COUVRE ETRIER | GOMA DEL PEDAL |
| 4m | 3 | 664 546 015 | | PLATTE | | PLATE | PLAQUE | PLACA |
| 4m | 4 | 664 729 601 | | SCHRAUBE | | SCREW | VIS | TORNILLO |
| 4m | 5 | 664 000 540 | | STANGE | | ROD | BARRE | BARRA |
| 4m | 6 | 664 523 040 | | SCHEIBE | | WASHER | RONDELLE | ARANDELA |
| 4m | 7 | 664 154 510 | | MUTTER | | NUT | ECROU | TUERCA |
| 4m | 8 | 664 521 350 | | SCHEIBE | | WASHER | RONDELLE | ARANDELA |
| 4m | 9 | 664 436 050 | | PLATTE | | PLATE | PLAQUE | PLACA |
| 4m | 10 | 664 785 261 | | HALTER | | SUPPORT | SUPPORT | SOPORTE |
| 4m | 11 | 664 815 200 | | SCHRAUBE | | SCREW | VIS | TORNILLO |
| 4m | 12 | 664 292 102 | | MUTTER | | NUT | ECROU | TUERCA |
| 4m | 13 | 664 000 531 | | STANGE | | ROD | BARRE | BARRA |
| 4m | 14 | 664 524 970 | | BOLZEN | | PIN | PIVOT | PIVOTE |
| 4m | 15 | 664 155 000 | | MUTTER | | NUT | ECROU | TUERCA |
| 4m | 16 | 664 430 213 | | FEDER | | SPRING | RESSORT | MUELLE |
| 4m | 31 | 664 510 035 | | BOLZEN | | PIN | PIVOT | PIVOTE |
| 4m | 32 | 664 774 247 | | HALTER | | BRACKET | ETRIER | SOPORTE |
| 4m | 33 | 664 672 152 | | SCHEIBE | | WASHER | RONDELLE | ARANDELA |
| 4m | 34 | 664 523 060 | | SCHEIBE | | WASHER | RONDELLE | ARANDELA |
| 4m | 35 | 664 155 010 | | MUTTER | | NUT | ECROU | TUERCA |
| 4m | 36 | 664 318 215 | | HEBEL | | LEVER | LEVIER | PALANCA |
| 4m | 37 | 664 394 510 | | GRIFF | | KNOB | POIGNEE | MANETA |
| 4m | 38 | 664 430 258 | | FEDER | | SPRING | RESSORT | MUELLE |
| 4m | 39 | 664 692 050 | | SCHRAUBE | | SCREW | VIS | TORNILLO |
| 4m | 40 | 664 155 000 | | MUTTER | | NUT | ECROU | TUERCA |
| 4m | 41 | 664 033 012 | | STANGE | | ROD | BARRE | BARRA |
| 4m | 42 | 664 746 601 | | GELENK | | JOINT | JOINT | ARTICULACIÓN |
| 4m | 43 | 664 155 000 | | MUTTER | | NUT | ECROU | TUERCA |
| 4m | 44 | 664 318 128 | | HEBEL | | LEVER | LEVIER | PALANCA |
| 4m | 46 | 664 141 418 | | SPLINT | | COTTER PIN | GOUPILLE | PASADOR |
| 4m | 47 | 664 689 500 | | SCHRAUBE | | SCREW | VIS | TORNILLO |
| 4m | 48 | 664 521 330 | | SCHEIBE | | WASHER | RONDELLE | ARANDELA |
| 4m | 49 | 664 154 510 | | MUTTER | | NUT | ECROU | TUERCA |

TM-92.14 (2009), TM-92.14 H
(2009), TM-92.14 H2 (2009)

4y

GETRIEBE UND BREMSE ANTRIEB
DRIVE AND BRAKE CONTROLS
COMMANDE TRANSMISSION ET FREIN
ACCIONAMIENTO TRANSMISIÓN Y FRENOS

DOLMAR
A member of the *Trakita* Group

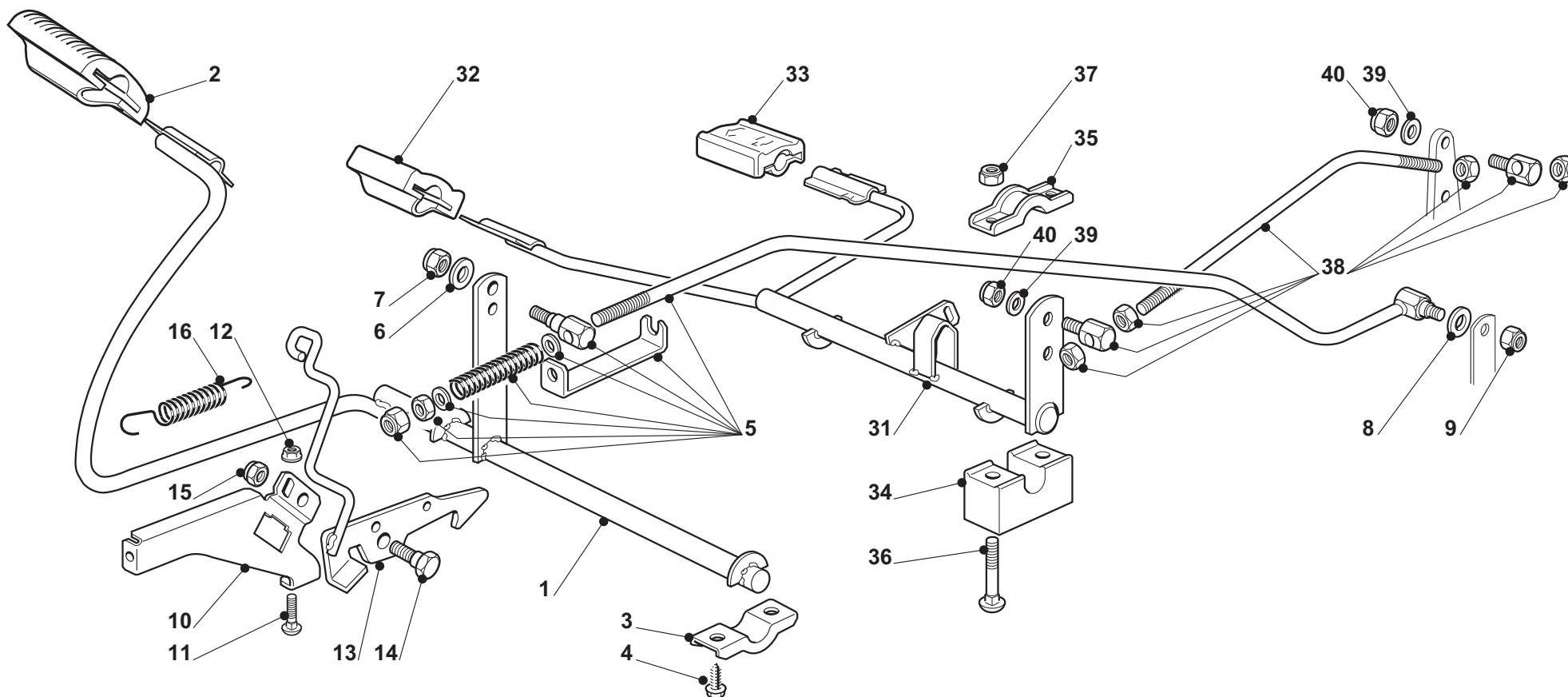

TM-92.14 (2009), TM-92.14 H
(2009), TM-92.14 H2 (2009)

4y

GETRIEBE UND BREMSE ANTRIEB
DRIVE AND BRAKE CONTROLS
COMMANDE TRANSMISSION ET FREIN
ACCIONAMIENTO TRANSMISIÓN Y FRENOS

DOLMAR
A member of the **Takita** Group

| Seite / Page | Pos. | TM-92.14 H (2009) | TM-92.14 H2 (2009) | Teil-Nr. Part No. No. de pièce No. de pieza | Hinweise Notes Renseign. Nota | Bezeichnung | Spezifikation Specification | Description | Désignation | Denominación |
|--------------|------|-------------------|--------------------|--|--|---------------|--------------------------------|-------------|---------------|----------------|
| 4y | 1 | 1 | 1 | 664 999 029 | | PEDAL | | PEDAL | PEDAL | PEDAL |
| 4y | 2 | 1 | 1 | 664 110 267 | | PEDALGUMMI | | PEDAL PAD | COUVRE ETRIER | GOMA DEL PEDAL |
| 4y | 3 | 2 | 2 | 664 546 015 | | PLATTE | | PLATE | PLAQUE | PLACA |
| 4y | 4 | 4 | 4 | 664 729 601 | | SCHRAUBE | | SCREW | VIS | TORNILLO |
| 4y | 5 | 1 | 1 | 664 000 542 | | STANGE | | ROD | BARRE | BARRA |
| 4y | 6 | 1 | 1 | 664 521 350 | | SCHEIBE | | WASHER | RONDELLE | ARANDELA |
| 4y | 7 | 1 | 1 | 664 155 000 | | MUTTER | | NUT | ECROU | TUERCA |
| 4y | 8 | 1 | 1 | 664 521 350 | | SCHEIBE | | WASHER | RONDELLE | ARANDELA |
| 4y | 9 | 1 | 1 | 664 155 000 | | MUTTER | | NUT | ECROU | TUERCA |
| 4y | 10 | 1 | 1 | 664 785 261 | | HALTER | | SUPPORT | SUPPORT | SOPORTE |
| 4y | 11 | 2 | 2 | 664 815 200 | | SCHRAUBE | | SCREW | VIS | TORNILLO |
| 4y | 12 | 2 | 2 | 664 292 102 | | MUTTER | | NUT | ECROU | TUERCA |
| 4y | 13 | 1 | 1 | 664 000 531 | | STANGE | | ROD | BARRE | BARRA |
| 4y | 14 | 1 | 1 | 664 524 970 | | BOLZEN | | PIN | PIVOT | PIVOTE |
| 4y | 15 | 1 | 1 | 664 155 000 | | MUTTER | | NUT | ECROU | TUERCA |
| 4y | 16 | 1 | 1 | 664 430 213 | | FEDER | | SPRING | RESSORT | MUELLE |
| 4y | 31 | 1 | 1 | 664 000 383 | | GETRIEBEPEDAL | | PEDAL | PEDAL | PEDAL |
| 4y | 32 | 1 | 1 | 664 110 274 | | PEDALGUMMI | | PEDAL PAD | COUVRE ETRIER | GOMA DEL PEDAL |
| 4y | 33 | 1 | 1 | 664 110 331 | | PEDALGUMMI | | PEDAL PAD | COUVRE ETRIER | GOMA DEL PEDAL |
| 4y | 34 | 2 | 2 | 664 785 185 | | HALTER | | SUPPORT | SUPPORT | SOPORTE |
| 4y | 35 | 2 | 2 | 664 546 015 | | PLATTE | | PLATE | PLAQUE | PLACA |
| 4y | 36 | 4 | 4 | 664 815 245 | | SCHRAUBE | | SCREW | VIS | TORNILLO |
| 4y | 37 | 4 | 4 | 664 154 510 | | MUTTER | | NUT | ECROU | TUERCA |
| 4y | 38 | 1 | 1 | 664 000 543 | | STANGE | | ROD | BARRE | BARRA |
| 4y | 39 | 2 | 2 | 664 523 040 | | SCHEIBE | | WASHER | RONDELLE | ARANDELA |
| 4y | 40 | 2 | 2 | 664 154 510 | | MUTTER | | NUT | ECROU | TUERCA |

TM-92.14 (2009), TM-92.14 H
(2009), TM-92.14 H2 (2009)

5

Motor
Motor
Moteur
Motor

DOLMAR
A member of the *Takita* Group

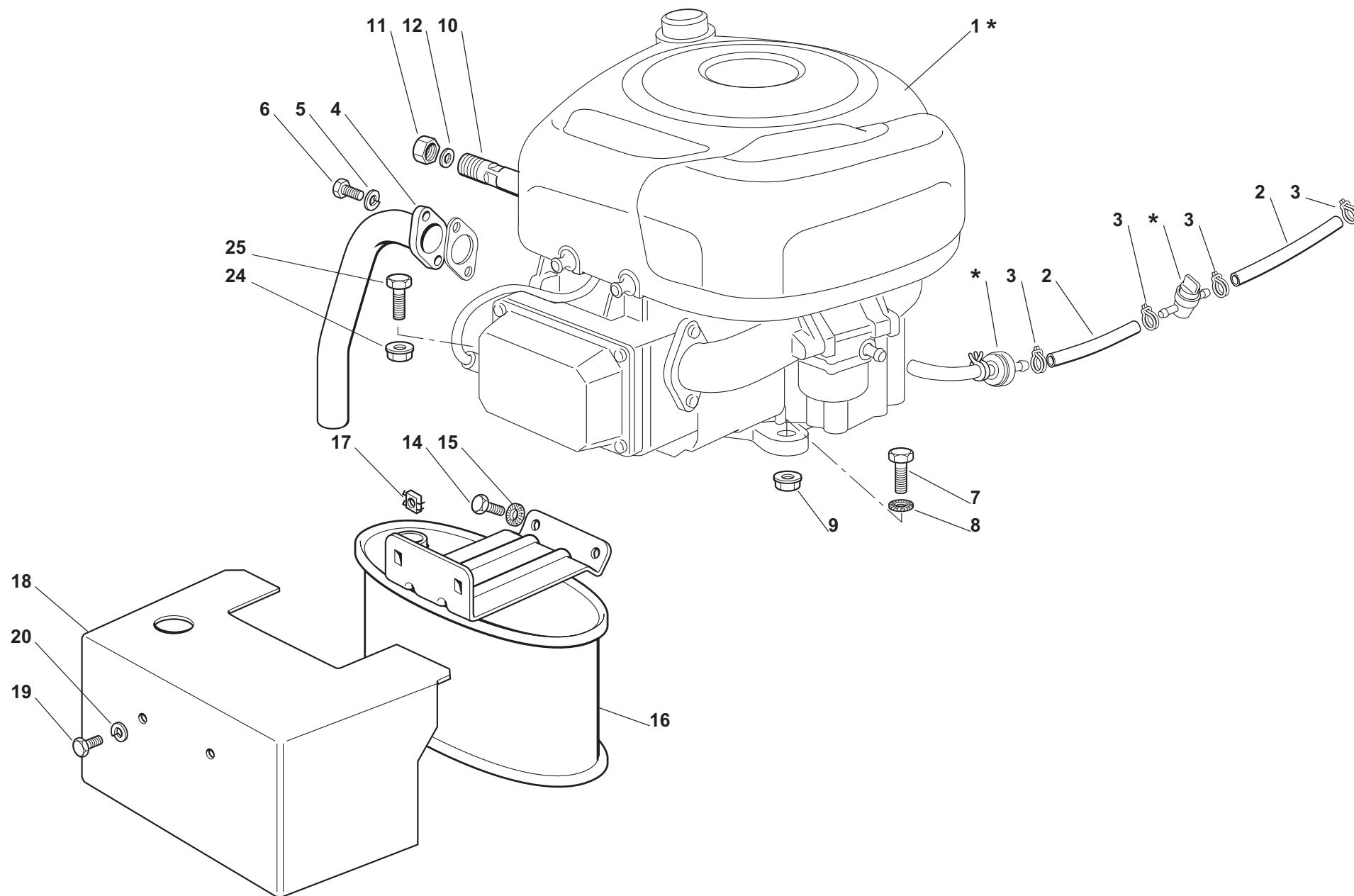

TM-92.14 (2009), TM-92.14 H
(2009), TM-92.14 H2 (2009)

5

Motor
Motor
Moteur
Motor

DOLMAR
A member of the **Takita** Group

| Seite / Page | Pos. | TM-92.14 (2009) | TM-92.14 H (2009) | Teil-Nr. Part No. No. de pièce No. de pieza | Hinweise Notes Renseign. Nota | Bezeichnung | Spezifikation Specification | Description | Désignation | Denominación |
|--------------|------|-----------------|-------------------|--|--|---|--------------------------------|--|---|---|
| 5 | * | x | x | | | ZUM AUSTAUSCH DER MIT «*» GEKENNZEICHNETEN TEILE, WENDEN SIE SICH AN DEN KUNDENDIENST DES MOTORHERSTELLERS. | | TO REPLACE THE PARTS MARKED «*» SEEK ASSISTANCE FROM THE ENGINE MANUFACTURER'S AFTER SALES SERVICE. | POUR LE REMPLACEMENT DES PIÈCES MARQUÉES AVEC «*» S'ADRESSER AU SERVICE APRÈS VENTES DU CONSTRUCTEUR DU MOTEUR. | PARA RECAMBIO DE LAS PIEZAS MARCADO CON <<*>> FAVOR SE DIRIGEN AL SERVICIO TÉCNICO DEL FABRICANTE DEL MOTOR. |
| 5 | 1* | 1 | 1 | | | MOTOR | | ENGINE | MOTEUR | MOTOR |
| 5 | 2 | 1 | 1 | 664 869 057 | | VERBINDUNGSROHR | | TUBE | TUBE | TUBO |
| 5 | 3 | 4 | 4 | 664 375 051 | | KABELBEFESTIGUNG | | FAIRLEAD | FIXATION CABLE | SUJETACABLE |
| 5 | 4 | 1 | 1 | 664 738 224 | | ABGASROHR | | TUBE | TUBE | TUBO |
| 5 | 5 | 2 | 2 | 664 583 500 | | FEDERRING | | GROWER | GROWER | ARANDELA ELÁSTICA |
| 5 | 6 | 2 | 2 | 664 735 530 | | SCHRAUBE | | SCREW | VIS | TORNILLO |
| 5 | 7 | 1 | 1 | 664 691 115 | | SCHRAUBE | | SCREW | VIS | TORNILLO |
| 5 | 8 | 1 | 1 | 664 540 260 | | SCHEIBE | | WASHER | RONDELLE | ARANDELA |
| 5 | 9 | 1 | 1 | 664 154 210 | | MUTTER | | NUT | ECROU | TUERCA |
| 5 | 10 | 1 | 1 | 664 598 050 | | ÖLABFLUSS | | OIL DISCHARGE EXTENSION | EXTENSION DECH. HUILE | TUBO |
| 5 | 11 | 1 | 1 | 664 737 849 | | ÖLVERSCHLUSS | | CAP | BOUCHON | TAPÓN |
| 5 | 12 | 1 | 1 | 664 401 001 | | DICHTUNG | | GASKET | JOINT | JUNTA |
| 5 | 14 | 2 | 2 | 664 793 102 | | SCHRAUBE | | SCREW | VIS | TORNILLO |
| 5 | 15 | 2 | 2 | 664 540 260 | | SCHEIBE | | WASHER | RONDELLE | ARANDELA |
| 5 | 16 | 1 | 1 | 664 750 004 | | AUSPUFF | | MUFFLER | SILENCIEUX | SILENCIADOR |
| 5 | 17 | 2 | 2 | 664 360 425 | | MUTTER | | NUT | ECROU | TUERCA |
| 5 | 18 | 1 | 1 | 664 598 009 | | SCHUTZ | | PROTECTION | PROTECTION | PROTECCIÓN |
| 5 | 19 | 2 | 2 | 664 792 611 | | SCHRAUBE | | SCREW | VIS | TORNILLO |
| 5 | 20 | 2 | 2 | 664 583 500 | | FEDERRING | | GROWER | GROWER | ARANDELA ELÁSTICA |
| 5 | 24 | 3 | 3 | 664 154 210 | | MUTTER | | NUT | ECROU | TUERCA |
| 5 | 25 | 3 | 3 | 664 691 100 | | SCHRAUBE | | SCREW | VIS | TORNILLO |

TM-92.14 (2009), TM-92.14 H
(2009), TM-92.14 H2 (2009)

5c

Motor
Motor
Moteur
Motor

DOLMAR

A member of the *Takita* Group

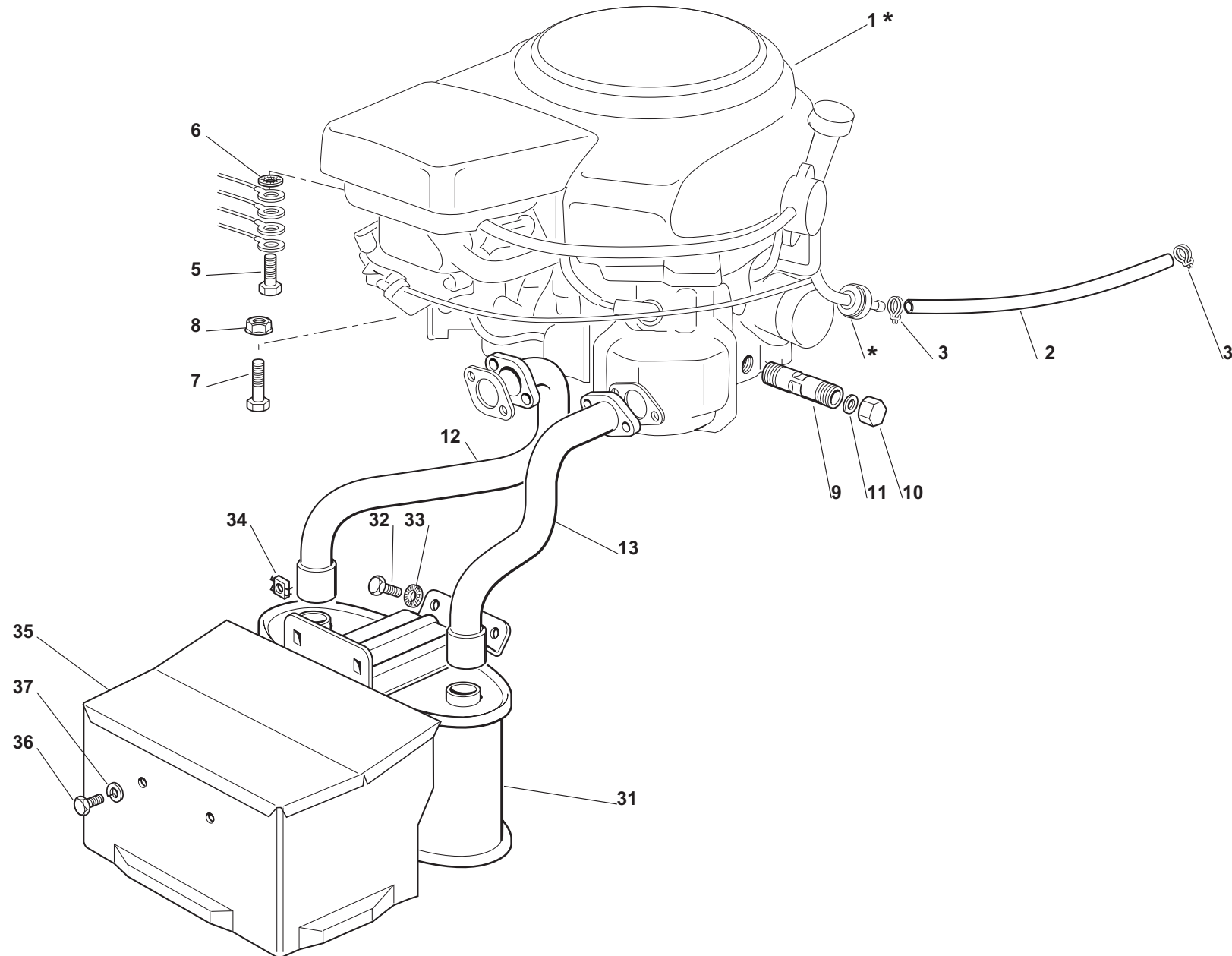

TM-92.14 (2009), TM-92.14 H
(2009), TM-92.14 H2 (2009)

5c

Motor
Motor
Moteur
Motor

DOLMAR
A member of the **Takita** Group

| Seite / Page | Pos. | TM-92.14 H2 (2009) | Teil-Nr. Part No. No. de pièce No. de pieza | Hinweise Notes Renseign. Nota | Bezeichnung | Spezifikation Specification | Description | Désignation | Denominación |
|--------------|------|--------------------|--|--|--|--------------------------------|--|---|---|
| 5c | * | x | | | ZUM AUSTAUSCH DER MIT «*» GEKENNZEICHNETEN TEILE, WENDEN SIE SICH AN DEN KUNDENDIENST DES MOTORHERSTELLERS. | | TO REPLACE THE PARTS MARKED «*» SEEK ASSISTANCE FROM THE ENGINE MANUFACTURER'S AFTER SALES SERVICE. | POUR LE REMPLACEMENT DES PIÈCES MARQUÉES AVEC «*» S'ADRESSER AU SERVICE APRÈS VENTES DU CONSTRUCTEUR DU MOTEUR. | PARA RECAMBIO DE LAS PIEZAS MARCADO CON <<*>> FAVOR SE DIRIGEN AL SERVICIO TÉCNICO DEL FABRICANTE DEL MOTOR. |
| 5c | 1* | 1 | | | MOTOR | | ENGINE | MOTEUR | MOTOR |
| 5c | 2 | 1 | 664 869 057 | | VERBINDUNGSROHR | | TUBE | TUBE | TUBO |
| 5c | 3 | 2 | 664 375 051 | | KABELBEFESTIGUNG | | FAIRLEAD | FIXATION CABLE | SUJETACABLE |
| 5c | 5 | 1 | 664 735 599 | | SCHRAUBE | | SCREW | VIS | TORNILLO |
| 5c | 6 | 1 | 664 540 260 | | SCHEIBE | | WASHER | RONDELLE | ARANDELA |
| 5c | 7 | 4 | 664 691 115 | | SCHRAUBE | | SCREW | VIS | TORNILLO |
| 5c | 8 | 4 | 664 154 210 | | MUTTER | | NUT | ECROU | TUERCA |
| 5c | 9 | 1 | 664 598 051 | | ÖLABFLUSS | | OIL DISCHARGE EXTENSION | EXTENSION DECH. HUILE | TUBO |
| 5c | 10 | 1 | 664 737 849 | | ÖLVERSCHLUSS | | CAP | BOUCHON | TAPÓN |
| 5c | 11 | 1 | 664 401 001 | | DICHTUNG | | GASKET | JOINT | JUNTA |
| 5c | 12 | 1 | 664 738 221 | | ABGASROHR RECHTS | | TUBE RIGHT | TUBE DROIT | TUBO DER. |
| 5c | 13 | 1 | 664 738 222 | | ABGASROHR LINKS | | TUBE LEFT | TUBE GAUCHE | TUBO IZQ. |
| 5c | 31 | 1 | 664 750 003 | | AUSPUFF | | MUFFLER | SILENCIEUX | SILENCIADOR |
| 5c | 32 | 2 | 664 793 102 | | SCHRAUBE | | SCREW | VIS | TORNILLO |
| 5c | 33 | 2 | 664 540 260 | | SCHEIBE | | WASHER | RONDELLE | ARANDELA |
| 5c | 34 | 2 | 664 360 425 | | MUTTER | | NUT | ECROU | TUERCA |
| 5c | 35 | 1 | 664 598 005 | | SCHUTZ | | PROTECTION | PROTECTION | PROTECCIÓN |
| 5c | 36 | 2 | 664 792 611 | | SCHRAUBE | | SCREW | VIS | TORNILLO |
| 5c | 37 | 2 | 664 583 500 | | FEDERRING | | GROWER | GROWER | ARANDELA ELÁSTICA |

TM-92.14 (2009), TM-92.14 H
(2009), TM-92.14 H2 (2009)

6m

Getriebe
Gear
Engrenage
Engranaje

DOLMAR



A member of the *Trakita* Group

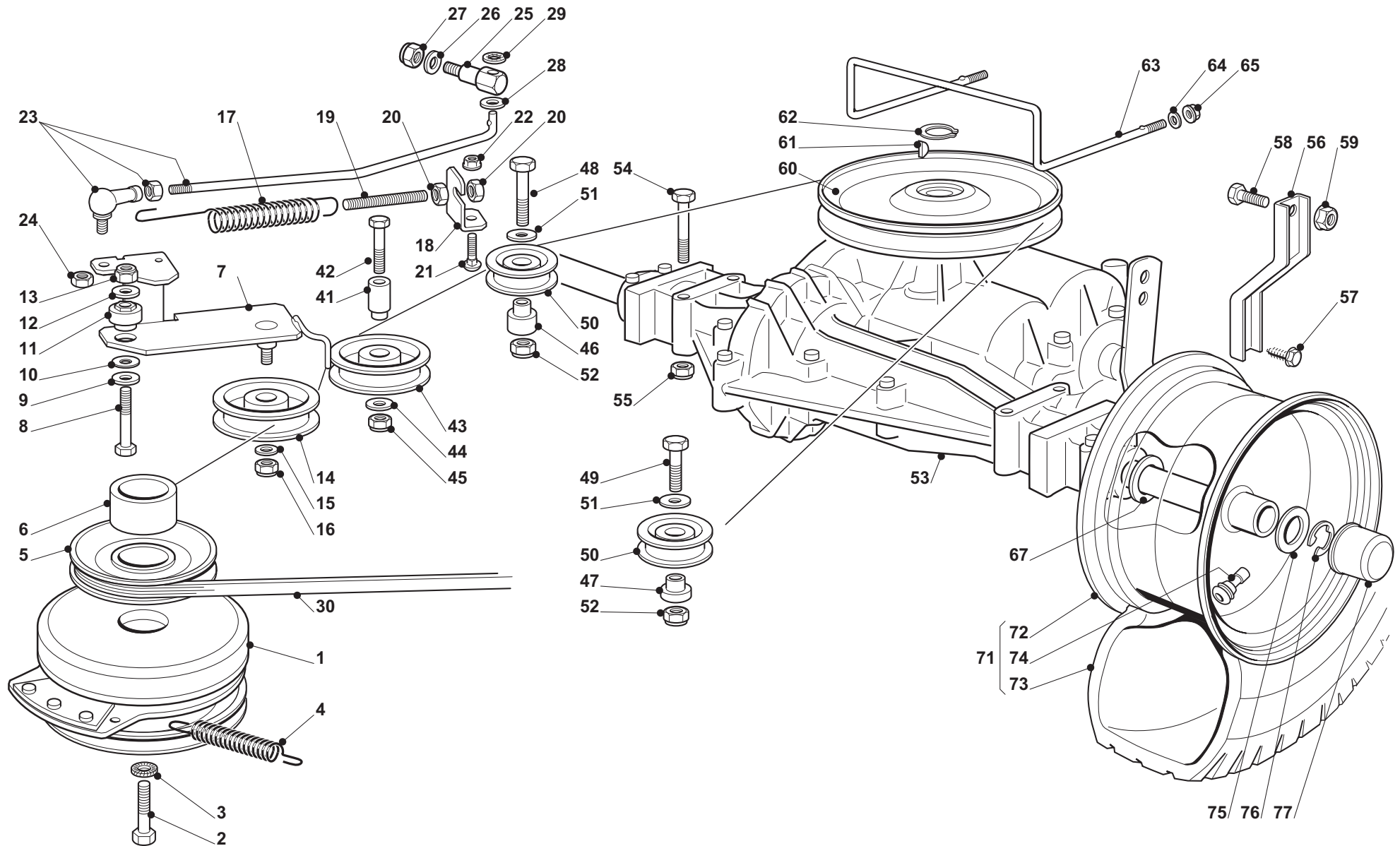

TM-92.14 (2009), TM-92.14 H
(2009), TM-92.14 H2 (2009)

6m

Getriebe
Gear
Engrenage
Engranaje

DOLMAR
A member of the **Takita** Group

| Seite / Page | Pos. | Teil-Nr. Part No. No. de pièce No. de pieza | Hinweise Notes Renseign. Nota | Bezeichnung | Spezifikation Specification | Description | Désignation | Denominación |
|--------------|------|--|--|---------------------|--------------------------------|---------------|----------------------|--------------------|
| 6m | 1 | 664 399 063 | | KUPPLUNG | | CLUTCH | EMBRAYAGE | EMBRAGUE |
| 6m | 2 | 664 737 320 | | SCHRAUBE | | SCREW | VIS | TORNILLO |
| 6m | 3 | 664 543 000 | | SCHEIBE | | WASHER | RONDELLE | ARANDELA |
| 6m | 4 | 664 430 216 | | FEDER | | SPRING | RESSORT | MUELLE |
| 6m | 5 | 664 601 567 | | RIEMENSCHLEIBE | | PULLEY | POULIE | POLEA |
| 6m | 6 | 664 160 021 | | DISTANZSTÜCK | | SPACER | ENTRETOISE | SEPARADOR |
| 6m | 7 | 664 318 217 | | HEBEL | | LEVER | LEVIER | PALANCA |
| 6m | 8 | 664 691 115 | | SCHRAUBE | | SCREW | VIS | TORNILLO |
| 6m | 9 | 664 523 060 | | SCHEIBE | | WASHER | RONDELLE | ARANDELA |
| 6m | 10 | 664 670 055 | | SCHEIBE | | WASHER | RONDELLE | ARANDELA |
| 6m | 11 | 664 510 087 | | BOLZEN | | PIN | PIVOT | PIVOTE |
| 6m | 12 | 664 523 060 | | SCHEIBE | | WASHER | RONDELLE | ARANDELA |
| 6m | 13 | 664 155 000 | | MUTTER | | NUT | ECROU | TUERCA |
| 6m | 14 | 664 601 554 | | RIEMENSCHLEIBE | | PULLEY | POULIE | POLEA |
| 6m | 15 | 664 523 060 | | SCHEIBE | | WASHER | RONDELLE | ARANDELA |
| 6m | 16 | 664 155 000 | | MUTTER | | NUT | ECROU | TUERCA |
| 6m | 17 | 664 430 260 | | FEDER | | SPRING | RESSORT | MUELLE |
| 6m | 18 | 664 755 049 | | WINKEL | | BRACKET | SUPPORT | SOPORTE |
| 6m | 19 | 664 840 005 | | SPANNSTANGE | | TIE ROD | TIRANT | TENSOR |
| 6m | 20 | 664 293 200 | | MUTTER | | NUT | ECROU | TUERCA |
| 6m | 21 | 664 818 690 | | SCHRAUBE | | SCREW | VIS | TORNILLO |
| 6m | 22 | 664 293 201 | | MUTTER | | NUT | ECROU | TUERCA |
| 6m | 23 | 664 820 013 | | SPANNSTANGE KPL. | | TIE ROD ASSY. | TIRANT | TENSOR |
| 6m | 23 | 664 840 005 | | SPANNSTANGE | | TIE ROD | TIRANT | TENSOR |
| 6m | 24 | 664 155 000 | | MUTTER | | NUT | ECROU | TUERCA |
| 6m | 25 | 664 510 063 | | BOLZEN | | PIN | PIVOT | PIVOTE |
| 6m | 26 | 664 670 011 | | SCHEIBE | | WASHER | RONDELLE | ARANDELA |
| 6m | 27 | 664 155 000 | | MUTTER | | NUT | ECROU | TUERCA |
| 6m | 28 | 664 521 350 | | SCHEIBE | | WASHER | RONDELLE | ARANDELA |
| 6m | 29 | 664 604 899 | | SICHERUNGSSCHLEIBE | | SAFETY WASHER | RONDELLE DE SÉCURITÉ | ARANDELA SEGURIDAD |
| 6m | 30 | 664 062 012 | | RIEMEN | | BELT | COURROIE | CORREA |
| 6m | 41 | 664 510 100 | | BOLZEN | | BOLT ASSY. | VIS CPL. | TORNILLO CPL. |
| 6m | 42 | 664 691 800 | | SCHRAUBE | | SCREW | VIS | TORNILLO |
| 6m | 43 | 664 601 555 | | RIEMENSCHLEIBE | | PULLEY | POULIE | POLEA |
| 6m | 44 | 664 523 060 | | SCHEIBE | | WASHER | RONDELLE | ARANDELA |
| 6m | 45 | 664 155 000 | | MUTTER | | NUT | ECROU | TUERCA |
| 6m | 46 | 664 160 014 | | DISTANZSTÜCK RECHTS | | SPACER | ENTRETOISE | SEPARADOR |
| 6m | 47 | 664 160 018 | | DISTANZSTÜCK LINKS | | SPACER LEFT | ENTRETOISE GAUCHE | SEPARADOR IZQ. |
| 6m | 48 | 664 691 200 | | SCHRAUBE | | SCREW | VIS | TORNILLO |
| 6m | 49 | 664 691 100 | | SCHRAUBE | | SCREW | VIS | TORNILLO |
| 6m | 50 | 664 601 588 | | RIEMENSCHLEIBE | | PULLEY | POULIE | POLEA |
| 6m | 51 | 664 671 653 | | SCHEIBE | | WASHER | RONDELLE | ARANDELA |

TM-92.14 (2009), TM-92.14 H
(2009), TM-92.14 H2 (2009)

6m

Getriebe
Gear
Engrenage
Engranaje

DOLMAR



A member of the *Trakita* Group

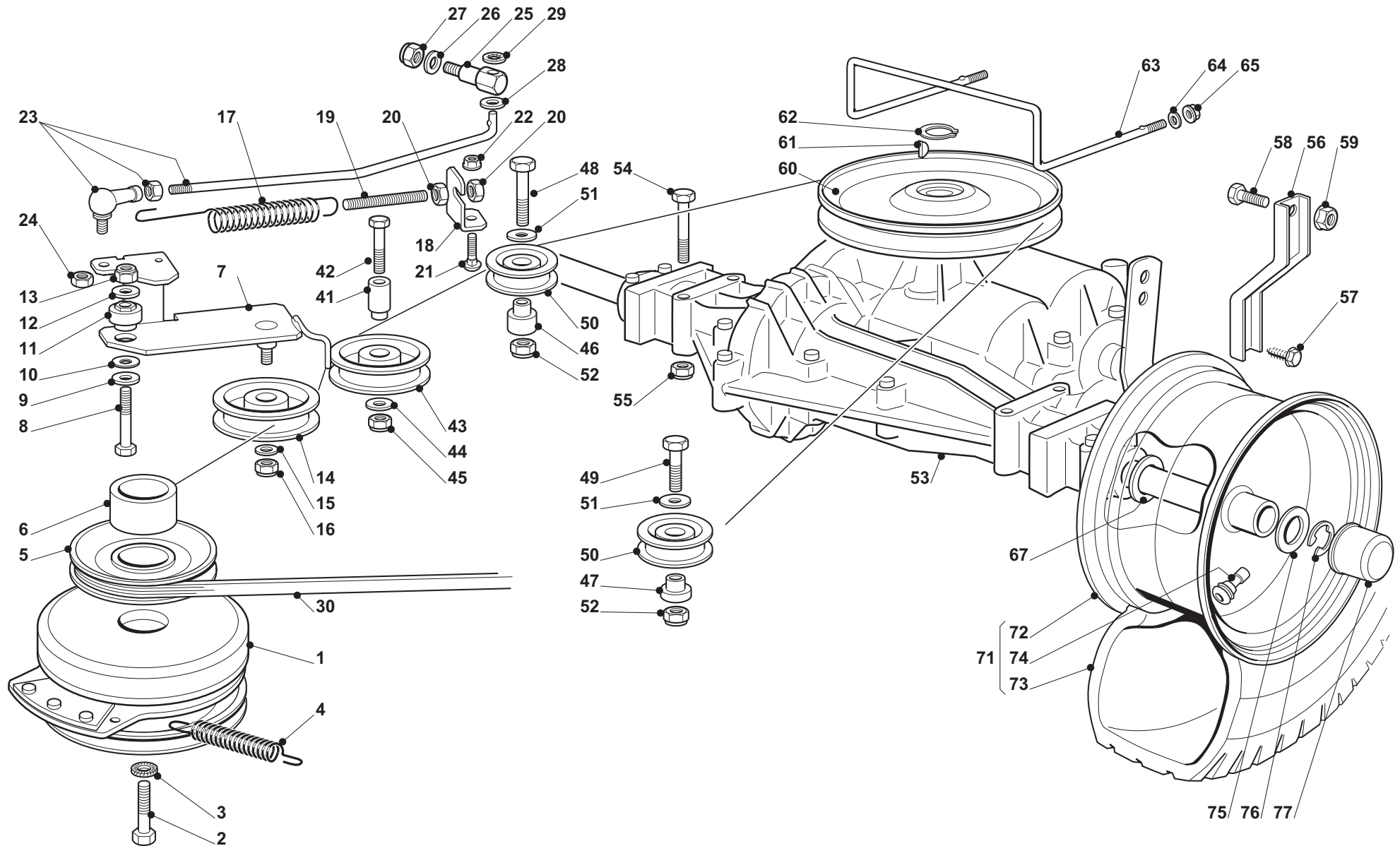

TM-92.14 (2009), TM-92.14 H
(2009), TM-92.14 H2 (2009)

6m

Getriebe
Gear
Engrenage
Engranaje

DOLMAR

A member of the **Takita** Group

| Seite / Page | Pos. | TM-92.14 (2009) | Teil-Nr. Part No. No. de pièce No. de pieza | Hinweise Notes Renseign. Nota | Bezeichnung | Spezifikation Specification | Description | Désignation | Denominación |
|--------------|------|-----------------|--|--|----------------|--------------------------------|-------------|--------------------|--------------------|
| 6m | 52 | 2 | 664 155 000 | | MUTTER | | NUT | ECROU | TUERCA |
| 6m | 53 | 1 | 664 400 910 | | HINTERACHSE | | REAR AXLE | AXE ARRIERE | EJE |
| 6m | 54 | 4 | 664 691 800 | | SCHRAUBE | | SCREW | VIS | TORNILLO |
| 6m | 55 | 4 | 664 154 210 | | MUTTER | | NUT | ECROU | TUERCA |
| 6m | 56 | 2 | 664 999 247 | | HALTER | | BRACKET | ETRIER | SOPORTE |
| 6m | 57 | 2 | 664 735 150 | | SCHRAUBE | | SCREW | VIS | TORNILLO |
| 6m | 58 | 2 | 664 792 611 | | SCHRAUBE | | SCREW | VIS | TORNILLO |
| 6m | 59 | 2 | 664 293 201 | | MUTTER | | NUT | ECROU | TUERCA |
| 6m | 60 | 1 | 664 601 509 | | RIEMENSCHLEIBE | | PULLEY | POULIE | POLEA |
| 6m | 61 | 1 | 664 139 430 | | KEIL | | KEY | CLAVETTE | CHAVETA |
| 6m | 62 | 1 | 664 608 950 | | SPRENGRING | | SNAP RING | ANNEAU RESSORT | ANILLO DE SUJECIÓN |
| 6m | 63 | 1 | 664 270 321 | | RIEMENFÜHRUNG | | BELT GUIDE | GUIDE DE COURROIRE | GUÍA DE LA CORREA |
| 6m | 64 | 2 | 664 523 040 | | SCHEIBE | | WASHER | RONDELLE | ARANDELA |
| 6m | 65 | 2 | 664 292 102 | | MUTTER | | NUT | ECROU | TUERCA |
| 6m | 67 | 2-4 | 664 521 410 | | SCHEIBE | | WASHER | RONDELLE | ARANDELA |
| 6m | 71 | 2 | 664 680 003 | | HINTERRAD | | WHEEL | ROUE | RUEDA |
| 6m | 72 | 2 | 664 000 592 | | FELGE | | RIMM | JANTE | LLANTA |
| 6m | 73 | 2 | 664 590 001 | | REIFEN | | SHOE | PNEU | NEUMÁTICO |
| 6m | 74 | 2 | 664 950 000 | | VENTIL | | VALVE | SOUPAPE | VÁLVULA |
| 6m | 75 | 2 | 664 670 005 | | SCHEIBE | | WASHER | RONDELLE | ARANDELA |
| 6m | 76 | 2 | 664 001 010 | | SPRENGRING | | SNAP RING | ANNEAU RESSORT | ANILLO DE SUJECIÓN |
| 6m | 77 | 2 | 664 110 230 | | NABENDECKEL | | HUB COVER | COUVRE MOYEU | TAPACUBOS |

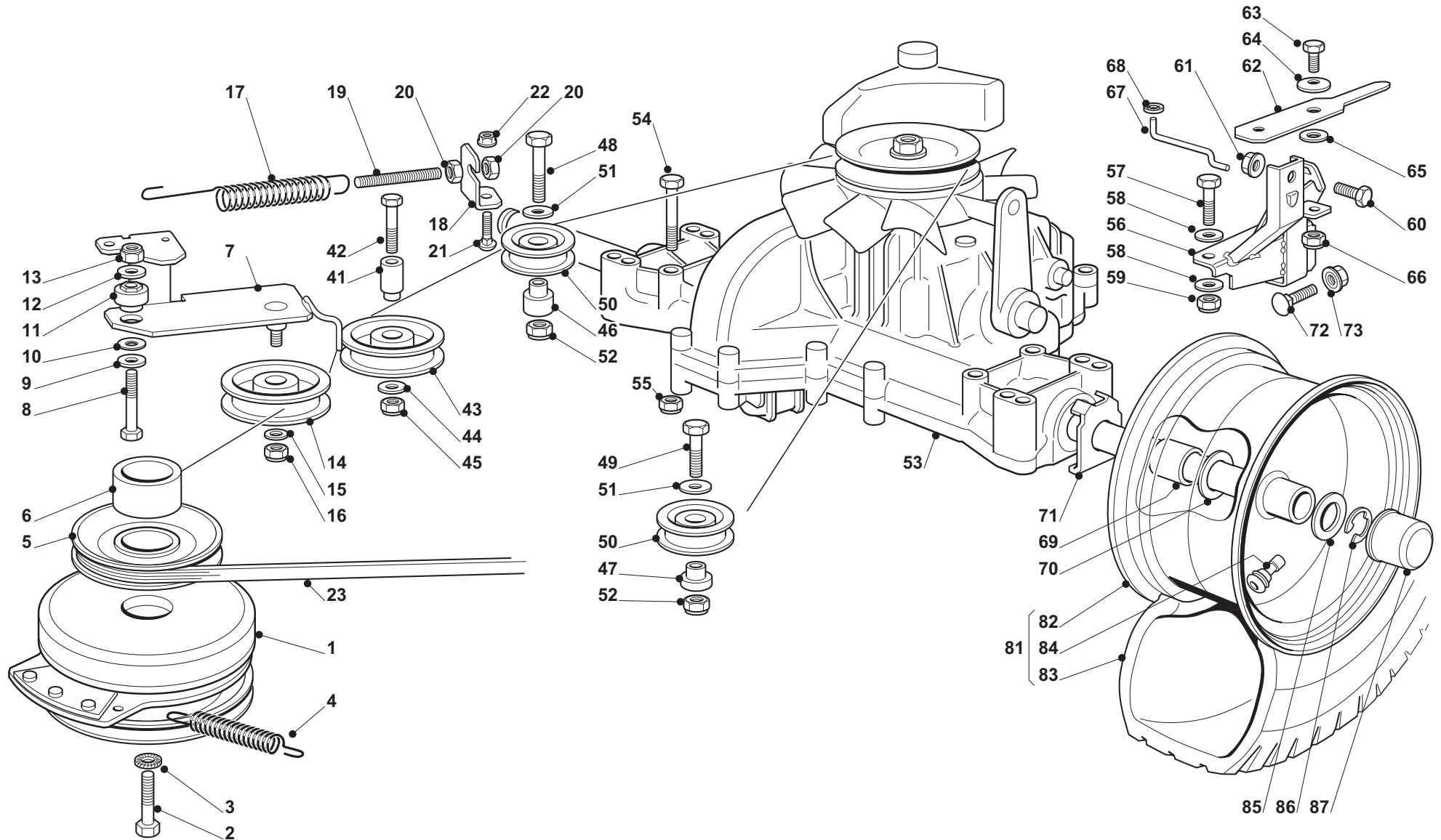

| Seite / Page | Pos. | TM-92.14 H (2009) | TM-92.14 H2 (2009) | Teil-Nr. Part No. No. de pièce No. de pieza | Hinweise Notes Renseign. Nota | Bezeichnung | Spezifikation Specification | Description | Désignation | Denominación |
|--------------|------|-------------------|--------------------|--|--|---------------------|--------------------------------|-------------|-------------|---------------|
| 6y | 1 | 1 | 1 | 664 399 063 | | KUPPLUNG | | CLUTCH | EMBRAYAGE | EMBRAGUE |
| 6y | 2 | 1 | 1 | 664 737 320 | | SCHRAUBE | | SCREW | VIS | TORNILLO |
| 6y | 3 | 1 | 1 | 664 543 000 | | SCHEIBE | | WASHER | RONDELLE | ARANDELA |
| 6y | 4 | 1 | 1 | 664 430 216 | | FEDER | | SPRING | RESSORT | MUELLE |
| 6y | 5 | 1 | 1 | 664 601 566 | | RIEMENSCHLEIBE | | PULLEY | POULIE | POLEA |
| 6y | 6 | 1 | 1 | 664 160 021 | | DISTANZSTÜCK | | SPACER | ENTRETOISE | SEPARADOR |
| 6y | 7 | 1 | 1 | 664 318 217 | | HEBEL | | LEVER | LEVIER | PALANCA |
| 6y | 8 | 1 | 1 | 664 691 115 | | SCHRAUBE | | SCREW | VIS | TORNILLO |
| 6y | 9 | 1 | 1 | 664 523 060 | | SCHEIBE | | WASHER | RONDELLE | ARANDELA |
| 6y | 10 | 1 | 1 | 664 670 055 | | SCHEIBE | | WASHER | RONDELLE | ARANDELA |
| 6y | 11 | 1 | 1 | 664 510 087 | | BOLZEN | | PIN | PIVOT | PIVOTE |
| 6y | 12 | 1 | 1 | 664 523 060 | | SCHEIBE | | WASHER | RONDELLE | ARANDELA |
| 6y | 13 | 1 | 1 | 664 155 000 | | MUTTER | | NUT | ECROU | TUERCA |
| 6y | 14 | 1 | 1 | 664 601 554 | | RIEMENSCHLEIBE | | PULLEY | POULIE | POLEA |
| 6y | 15 | 1 | 1 | 664 523 060 | | SCHEIBE | | WASHER | RONDELLE | ARANDELA |
| 6y | 16 | 1 | 1 | 664 155 000 | | MUTTER | | NUT | ECROU | TUERCA |
| 6y | 17 | 1 | 1 | 664 430 260 | | FEDER | | SPRING | RESSORT | MUELLE |
| 6y | 18 | 1 | 1 | 664 755 049 | | WINKEL | | BRACKET | SUPPORT | SOPORTE |
| 6y | 19 | 1 | 1 | 664 840 005 | | SPANNSTANGE | | TIE ROD | TIRANT | TENSOR |
| 6y | 20 | 2 | 2 | 664 293 200 | | MUTTER | | NUT | ECROU | TUERCA |
| 6y | 21 | 1 | 1 | 664 818 690 | | SCHRAUBE | | SCREW | VIS | TORNILLO |
| 6y | 22 | 1 | 1 | 664 293 201 | | MUTTER | | NUT | ECROU | TUERCA |
| 6y | 23 | 1 | 1 | 664 062 001 | | RIEMEN | | BELT | COURROIE | CORREA |
| 6y | 41 | 1 | 1 | 664 510 100 | | BOLZEN | | BOLT ASSY. | VIS CPL. | TORNILLO CPL. |
| 6y | 42 | 1 | 1 | 664 691 800 | | SCHRAUBE | | SCREW | VIS | TORNILLO |
| 6y | 43 | 1 | 1 | 664 601 555 | | RIEMENSCHLEIBE | | PULLEY | POULIE | POLEA |
| 6y | 44 | 1 | 1 | 664 523 060 | | SCHEIBE | | WASHER | RONDELLE | ARANDELA |
| 6y | 45 | 1 | 1 | 664 155 000 | | MUTTER | | NUT | ECROU | TUERCA |
| 6y | 46 | 1 | 1 | 664 160 024 | | DISTANZSTÜCK RECHTS | | SPACER | ENTRETOISE | SEPARADOR |
| 6y | 47 | 1 | 1 | 664 160 030 | | DISTANZSTÜCK LINKS | | SPACER | ENTRETOISE | SEPARADOR |
| 6y | 48 | 1 | 1 | 664 691 400 | | SCHRAUBE | | SCREW | VIS | TORNILLO |
| 6y | 49 | 1 | 1 | 664 691 115 | | SCHRAUBE | | SCREW | VIS | TORNILLO |
| 6y | 50 | 2 | 2 | 664 601 588 | | RIEMENSCHLEIBE | | PULLEY | POULIE | POLEA |
| 6y | 51 | 2 | 2 | 664 671 653 | | SCHEIBE | | WASHER | RONDELLE | ARANDELA |
| 6y | 52 | 2 | 2 | 664 155 000 | | MUTTER | | NUT | ECROU | TUERCA |
| 6y | 53 | 1 | 1 | 664 400 960 | | HINTERACHSE | | AXLE | AXE | EJE |
| 6y | 54 | 4 | 4 | 664 691 800 | | SCHRAUBE | | SCREW | VIS | TORNILLO |
| 6y | 55 | 4 | 4 | 664 154 210 | | MUTTER | | NUT | ECROU | TUERCA |
| 6y | 56 | 1 | 1 | 664 999 149 | | HALTER | | SUPPORT | SUPPORT | SOPORTE |
| 6y | 57 | 1 | 1 | 664 691 200 | | SCHRAUBE | | SCREW | VIS | TORNILLO |
| 6y | 58 | 2 | 2 | 664 521 350 | | SCHEIBE | | WASHER | RONDELLE | ARANDELA |
| 6y | 59 | 1 | 1 | 664 155 000 | | MUTTER | | NUT | ECROU | TUERCA |

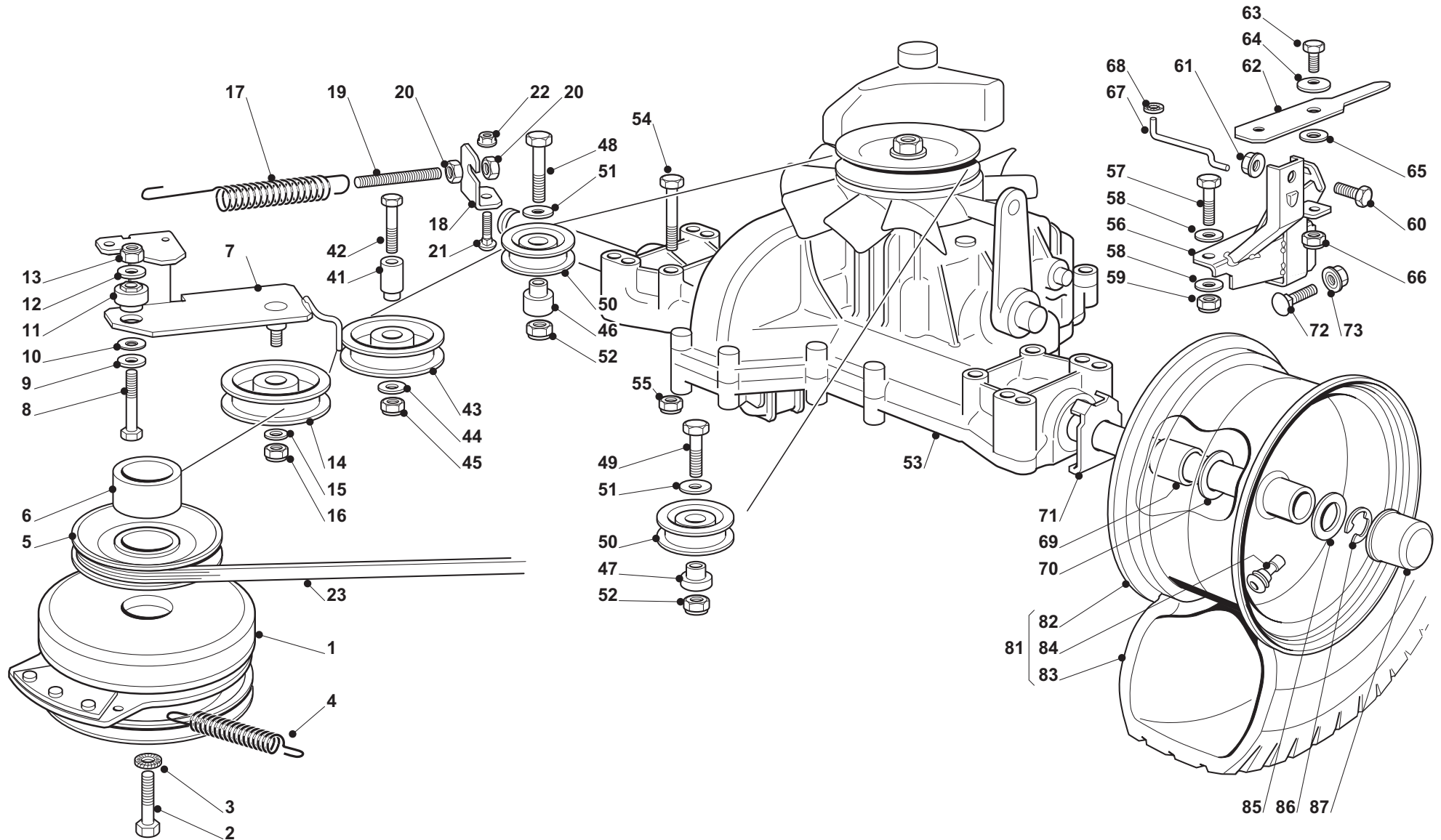

TM-92.14 (2009), TM-92.14 H
(2009), TM-92.14 H2 (2009)

6y

Getriebe
Gear
Engrenage
Engranaje

DOLMAR

A member of the **Takita** Group

| Seite / Page | Pos. | TM-92.14 H (2009) | TM-92.14 H2 (2009) | Teil-Nr. Part No. No. de pièce No. de pieza | Hinweise Notes Renseign. Nota | Bezeichnung | Spezifikation Specification | Description | Désignation | Denominación |
|--------------|------|-------------------|--------------------|--|--|-------------------|--------------------------------|----------------|----------------------|---------------------|
| 6y | 60 | 1 | 1 | 664 792 611 | | SCHRAUBE | | SCREW | VIS | TORNILLO |
| 6y | 61 | 1 | 1 | 664 293 201 | | MUTTER | | NUT | ECROU | TUERCA |
| 6y | 62 | 1 | 1 | 664 318 157 | | HEBEL | | LEVER | LEVIER | PALANCA |
| 6y | 63 | 1 | 1 | 664 793 102 | | SCHRAUBE | | SCREW | VIS | TORNILLO |
| 6y | 64 | 1 | 1 | 664 369 500 | | FEDERSCHEIBE | | ELASTIC WASHER | DISQUE ELASTIQUE | ARANDELA ELÁSTICA |
| 6y | 65 | 1 | 1 | 664 670 011 | | SCHEIBE | | WASHER | RONDELLE | ARANDELA |
| 6y | 66 | 1 | 1 | 664 155 000 | | MUTTER | | NUT | ECROU | TUERCA |
| 6y | 67 | 1 | 1 | 664 033 033 | | STANGE | | ROD | BARRE | BARRA |
| 6y | 68 | 1 | 1 | 664 604 896 | | SICHERUNGSSCHEIBE | | SAFETY WASHER | RONDELLE DE SÉCURITÉ | ARANDELA SEGURIDAD |
| 6y | 69 | 2 | 2 | 664 160 031 | | DISTANZSTÜCK | | SPACER | ENTRETOISE | SEPARADOR |
| 6y | 70 | 2-4 | 2-4 | 664 521 410 | | SCHEIBE | | WASHER | RONDELLE | ARANDELA |
| 6y | 71 | 2 | 2 | 664 670 025 | | SCHEIBE | | WASHER | RONDELLE | ARANDELA |
| 6y | 72 | 1 | 1 | 664 792 611 | | SCHRAUBE | | SCREW | VIS | TORNILLO |
| 6y | 73 | 1 | 1 | 664 293 201 | | MUTTER | | NUT | ECROU | TUERCA |
| 6y | 81 | 2 | 2 | 664 680 003 | | HINTERRAD | | WHEEL | ROUE | RUEDA |
| 6y | 82 | 2 | 2 | 664 000 592 | | FELGE | | RIMM | JANTE | LLANTA |
| 6y | 83 | 2 | 2 | 664 590 001 | | REIFEN | | SHOE | PNEU | NEUMÁTICO |
| 6y | 84 | 2 | 2 | 664 950 000 | | VENTIL | | VALVE | SOUPAPE | VÁLVULA |
| 6y | 85 | 2 | 2 | 664 670 005 | | SCHEIBE | | WASHER | RONDELLE | ARANDELA |
| 6y | 86 | 2 | 2 | 664 001 010 | | SPRENGRING | | SNAP RING | ANNEAU RESSORT | ANILLO DE SUJECCIÓN |
| 6y | 87 | 2 | 2 | 664 110 230 | | NABENDECKEL | | HUB COVER | COUVRE MOYEU | TAPACUBOS |

TM-92.14 (2009), TM-92.14 H
(2009), TM-92.14 H2 (2009)

7

SCHNEIDWERKZEUG AUFHEBESATZ
CUTTING PLATE LIFTING
SOULEVEMENT PLATEAU DE COUPE
HERRAMIENTA DE CORTE PLATO DE ELEVACIÓN

DOLMAR



A member of the *Trakita* Group

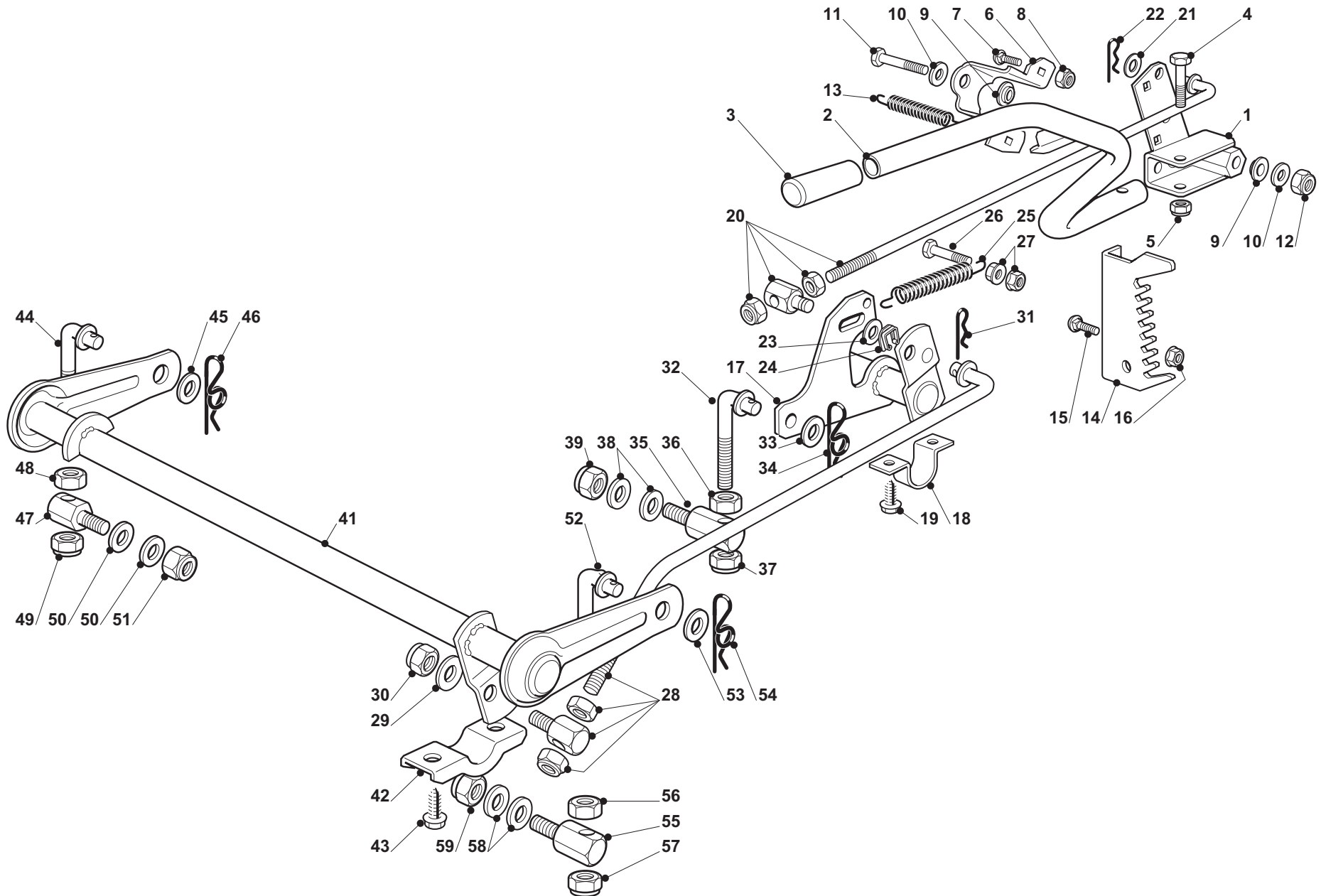

TM-92.14 (2009), TM-92.14 H
(2009), TM-92.14 H2 (2009)

7

SCHNEIDWERKZEUG AUFHEBESATZ
CUTTING PLATE LIFTING
SOULEVEMENT PLATEAU DE COUPE
HERRAMIENTA DE CORTE PLATO DE ELEVACIÓN

DOLMAR



A member of the **Takita** Group

| Seite / Page | Pos. | TM-92.14 (2009) | TM-92.14 H (2009) | TM-92.14 H2 (2009) | Teil-Nr. Part No. No. de pièce No. de pieza | Hinweise Notes Renseign. Nota | Bezeichnung | Spezifikation Specification | Description | Désignation | Denominación |
|--------------|------|-----------------|-------------------|--------------------|--|--|-----------------|--------------------------------|----------------|-------------------|--------------|
| 7 | 1 | 1 | 1 | 1 | 664 774 249 | | HALTER | | BRACKET | ETRIER | SOPORTE |
| 7 | 2 | 1 | 1 | 1 | 664 318 219 | | HEBEL | | LEVER | LEVIER | PALANCA |
| 7 | 3 | 1 | 1 | 1 | 664 999 005 | | GRIFF | | HANDLE | POINGEE | MANGO |
| 7 | 4 | 1 | 1 | 1 | 664 674 700 | | SCHRAUBE | | SCREW | VIS | TORNILLO |
| 7 | 5 | 1 | 1 | 1 | 664 154 510 | | MUTTER | | NUT | ECROU | TUERCA |
| 7 | 6 | 1 | 1 | 1 | 664 650 113 | | PLATTE | | PLATE | PLAQUE | PLACA |
| 7 | 7 | 2 | 2 | 2 | 664 818 690 | | SCHRAUBE | | SCREW | VIS | TORNILLO |
| 7 | 8 | 2 | 2 | 2 | 664 155 000 | | MUTTER | | NUT | ECROU | TUERCA |
| 7 | 9 | 2 | 2 | 2 | 664 041 980 | | BUCHSE | | BUSH | DOUILLE | CASQUILLO |
| 7 | 10 | 2 | 2 | 2 | 664 523 060 | | SCHEIBE | | WASHER | RONDELLE | ARANDELA |
| 7 | 11 | 1 | 1 | 1 | 664 691 600 | | SCHRAUBE | | SCREW | VIS | TORNILLO |
| 7 | 12 | 1 | 1 | 1 | 664 155 000 | | MUTTER | | NUT | ECROU | TUERCA |
| 7 | 13 | 1 | 1 | 1 | 664 430 259 | | FEDER | | SPRING | RESSORT | MUELLE |
| 7 | 14 | 1 | 1 | 1 | 664 735 511 | | SEKTOR | | SECTOR | SECTEUR | SECTOR |
| 7 | 15 | 2 | 2 | 2 | 664 818 690 | | SCHRAUBE | | SCREW | VIS | TORNILLO |
| 7 | 16 | 2 | 2 | 2 | 664 293 201 | | MUTTER | | NUT | ECROU | TUERCA |
| 7 | 17 | 1 | 1 | 1 | 664 000 387 | | ACHSE | | AXLE | AXE | EJE |
| 7 | 18 | 2 | 2 | 2 | 664 547 041 | | PLATTE | | PLATE | PLAQUE | PLACA |
| 7 | 19 | 4 | 4 | 4 | 664 731 601 | | SCHRAUBE | | SCREW | VIS | TORNILLO |
| 7 | 20 | 1 | 1 | 1 | 664 000 536 | | STAB | | ROD | TIGE | VARILLA |
| 7 | 21 | 1 | 1 | 1 | 664 670 011 | | SCHEIBE | | WASHER | RONDELLE | ARANDELA |
| 7 | 22 | 1 | 1 | 1 | 664 487 997 | | SPLINT | | COTTER PIN | GOUPILLE | PASADOR |
| 7 | 23 | 1 | 1 | 1 | 664 670 008 | | SCHEIBE | | WASHER | RONDELLE | ARANDELA |
| 7 | 24 | 1 | 1 | 1 | 664 436 050 | | PLATTE | | PLATE | PLAQUE | PLACA |
| 7 | 25 | 1 | 1 | 1 | 664 446 402 | | FEDER | | SPRING | RESSORT | MUELLE |
| 7 | 26 | 1 | 1 | 1 | 664 792 410 | | SCHRAUBE | | SCREW | VIS | TORNILLO |
| 7 | 27 | 2 | 2 | 2 | 664 292 102 | | MUTTER | | NUT | ECROU | TUERCA |
| 7 | 28 | 1 | 1 | 1 | 664 000 537 | | VERBINDUNGSSTAB | | CONNECTING ROD | TIGE DE CONNEXION | VARILLA |
| 7 | 29 | 2 | 2 | 2 | 664 670 008 | | SCHEIBE | | WASHER | RONDELLE | ARANDELA |
| 7 | 30 | 1 | 1 | 1 | 664 156 602 | | MUTTER | | NUT | ECROU | TUERCA |
| 7 | 31 | 1 | 1 | 1 | 664 487 997 | | SPLINT | | COTTER PIN | GOUPILLE | PASADOR |
| 7 | 32 | 1 | 1 | 1 | 664 840 025 | | SPANNSTANGE | | TIE ROD | TIRANT | SENSOR |
| 7 | 33 | 1 | 1 | 1 | 664 670 008 | | SCHEIBE | | WASHER | RONDELLE | ARANDELA |
| 7 | 34 | 1 | 1 | 1 | 664 487 997 | | SPLINT | | COTTER PIN | GOUPILLE | PASADOR |
| 7 | 35 | 1 | 1 | 1 | 664 510 090 | | BOLZEN | | PIN | PIVOT | PIVOTE |
| 7 | 36 | 1 | 1 | 1 | 664 295 200 | | MUTTER | | NUT | ECROU | TUERCA |
| 7 | 37 | 1 | 1 | 1 | 664 156 602 | | MUTTER | | NUT | ECROU | TUERCA |
| 7 | 38 | 2 | 2 | 2 | 664 670 008 | | SCHEIBE | | WASHER | RONDELLE | ARANDELA |
| 7 | 39 | 1 | 1 | 1 | 664 156 602 | | MUTTER | | NUT | ECROU | TUERCA |
| 7 | 41 | 1 | 1 | 1 | 664 000 385 | | ACHSE | | AXLE | AXE | EJE |
| 7 | 42 | 2 | 2 | 2 | 664 546 015 | | PLATTE | | PLATE | PLAQUE | PLACA |
| 7 | 43 | 4 | 4 | 4 | 664 731 350 | | SCHRAUBE | | SCREW | VIS | TORNILLO |

TM-92.14 (2009), TM-92.14 H
(2009), TM-92.14 H2 (2009)

7

SCHNEIDWERKZEUG AUFHEBESATZ
CUTTING PLATE LIFTING
SOULEVEMENT PLATEAU DE COUPE
HERRAMIENTA DE CORTE PLATO DE ELEVACIÓN

DOLMAR



A member of the *Trakita* Group

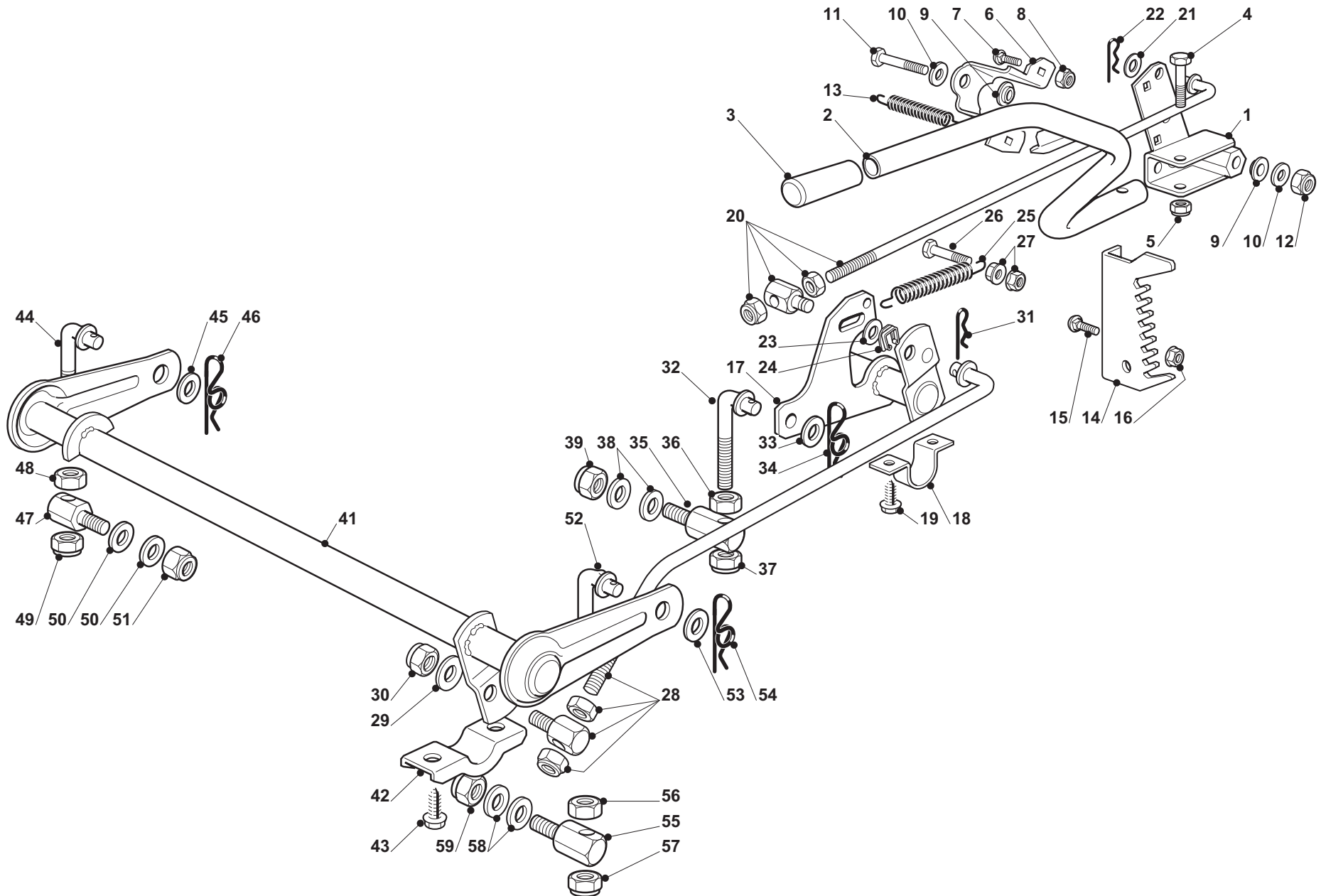

TM-92.14 (2009), TM-92.14 H
(2009), TM-92.14 H2 (2009)

7

SCHNEIDWERKZEUG AUFHEBESATZ
CUTTING PLATE LIFTING
SOULEVEMENT PLATEAU DE COUPE
HERRAMIENTA DE CORTE PLATO DE ELEVACIÓN

DOLMAR
A member of the **Takita** Group

| Seite / Page | Pos. | TM-92.14 (2009) | TM-92.14 H (2009) | TM-92.14 H2 (2009) | Teil-Nr. Part No. No. de pièce No. de pieza | Hinweise Notes Renseign. Nota | Bezeichnung | Spezifikation Specification | Description | Désignation | Denominación |
|--------------|------|-----------------|-------------------|--------------------|--|--|-------------|--------------------------------|-------------|-------------|--------------|
| 7 | 44 | 1 | 1 | 1 | 664 840 024 | | SPANNSTANGE | | TIE ROD | TIRANT | SENSOR |
| 7 | 45 | 1 | 1 | 1 | 664 670 008 | | SCHEIBE | | WASHER | RONDELLE | ARANDELA |
| 7 | 46 | 1 | 1 | 1 | 664 487 997 | | SPLINT | | COTTER PIN | GOUPILLE | PASADOR |
| 7 | 47 | 1 | 1 | 1 | 664 510 098 | | BOLZEN | | PIN | PIVOT | PIVOTE |
| 7 | 48 | 1 | 1 | 1 | 664 295 200 | | MUTTER | | NUT | ECROU | TUERCA |
| 7 | 49 | 1 | 1 | 1 | 664 156 602 | | MUTTER | | NUT | ECROU | TUERCA |
| 7 | 50 | 2 | 2 | 2 | 664 670 008 | | SCHEIBE | | WASHER | RONDELLE | ARANDELA |
| 7 | 51 | 1 | 1 | 1 | 664 156 602 | | MUTTER | | NUT | ECROU | TUERCA |
| 7 | 52 | 1 | 1 | 1 | 664 840 025 | | SPANNSTANGE | | TIE ROD | TIRANT | SENSOR |
| 7 | 53 | 1 | 1 | 1 | 664 670 008 | | SCHEIBE | | WASHER | RONDELLE | ARANDELA |
| 7 | 54 | 1 | 1 | 1 | 664 487 997 | | SPLINT | | COTTER PIN | GOUPILLE | PASADOR |
| 7 | 55 | 1 | 1 | 1 | 664 510 090 | | BOLZEN | | PIN | PIVOT | PIVOTE |
| 7 | 56 | 1 | 1 | 1 | 664 295 200 | | MUTTER | | NUT | ECROU | TUERCA |
| 7 | 57 | 1 | 1 | 1 | 664 156 602 | | MUTTER | | NUT | ECROU | TUERCA |
| 7 | 58 | 2 | 2 | 2 | 664 670 008 | | SCHEIBE | | WASHER | RONDELLE | ARANDELA |
| 7 | 59 | 1 | 1 | 1 | 664 156 602 | | MUTTER | | NUT | ECROU | TUERCA |

TM-92.14 (2009), TM-92.14 H
(2009), TM-92.14 H2 (2009)

8

SCHNEIDWERKZEUG (1)
CUTTING PLATE (1)
PLATEAU DE COUPE (1)
HERRAMIENTA DE CORTE (1)

DOLMAR



A member of the *Trakita* Group

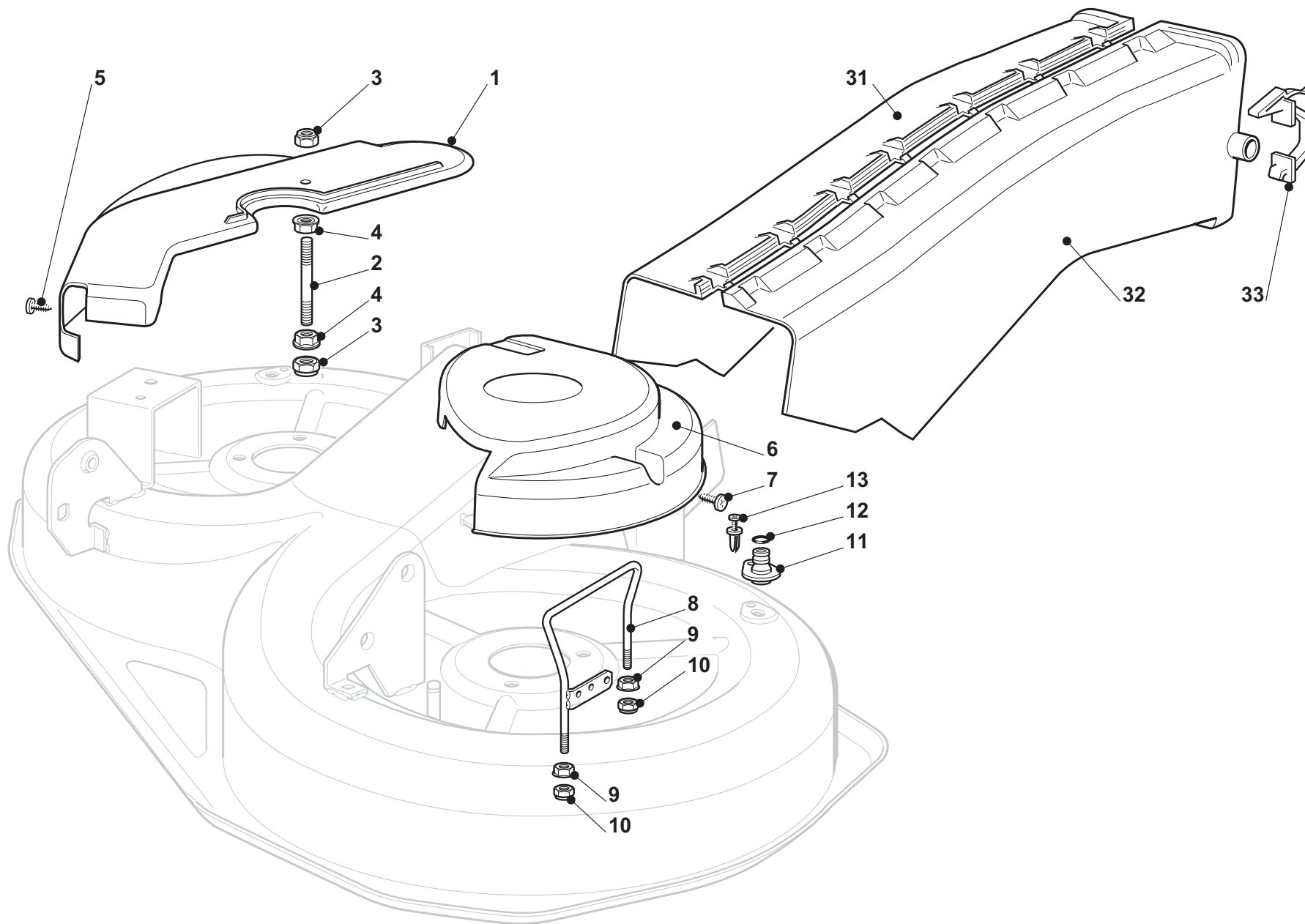

TM-92.14 (2009), TM-92.14 H
(2009), TM-92.14 H2 (2009)

8

SCHNEIDWERKZEUG (1)
CUTTING PLATE (1)
PLATEAU DE COUPE (1)
HERRAMIENTA DE CORTE (1)

DOLMAR
A member of the **Takita** Group

| Seite / Page | Pos. | TM-92.14 (2009) | TM-92.14 H (2009) | TM-92.14 H2 (2009) | Teil-Nr. Part No. No. de pièce No. de pieza | Hinweise Notes Renseign. Nota | Bezeichnung | Spezifikation Specification | Description | Désignation | Denominación |
|--------------|------|-----------------|-------------------|--------------------|--|--|------------------------|--------------------------------|-----------------------|-------------------------|-------------------------------|
| 8 | 1 | 1 | 1 | 1 | 664 060 115 | | GEHÄUSE | | CASE | CARTER | CÁRTER |
| 8 | 2 | 1 | 1 | 1 | 664 580 007 | | STIFTSCHRAUBE | | SCREW | VIS | TORNILLO |
| 8 | 3 | 2 | 2 | 2 | 664 155 000 | | MUTTER | | NUT | ECROU | TUERCA |
| 8 | 4 | 2 | 2 | 2 | 664 293 201 | | MUTTER | | NUT | ECROU | TUERCA |
| 8 | 5 | 2 | 2 | 2 | 664 735 110 | | SCHRAUBE | | SCREW | VIS | TORNILLO |
| 8 | 6 | 1 | 1 | 1 | 664 060 116 | | GEHÄUSE | | CASE | CARTER | CÁRTER |
| 8 | 7 | 2 | 2 | 2 | 664 735 110 | | SCHRAUBE | | SCREW | VIS | TORNILLO |
| 8 | 8 | 1 | 1 | 1 | 664 999 301 | | RIEMENFÜHRUNG | | BELT GUIDE | GUIDE DE COURROIRE | GUÍA DE LA CORREA |
| 8 | 9 | 2 | 2 | 2 | 664 293 201 | | MUTTER | | NUT | ECROU | TUERCA |
| 8 | 10 | 2 | 2 | 2 | 664 155 000 | | MUTTER | | NUT | ECROU | TUERCA |
| 8 | 11 | 2 | 2 | 2 | 664 033 060 | | WASSERANSCHLUSS | | WATER HOSE CONNECTION | RACCORD TUYAU D'EAU | TOMA DE AGUA |
| 8 | 12 | 2 | 2 | 2 | 664 035 000 | | O-RING | | O-RING | O-RING | JUNTA TÓRICA |
| 8 | 13 | 2 | 2 | 2 | 664 500 030 | | NIET | | RIVET | RIVET | REMACHE |
| 8 | 31 | 1 | 1 | 1 | 664 108 008 | | AUSWURF BLECHSATZ KPL. | | EXIT CONVEYOR A CPL. | EJECTION CONVOYEUR CPL. | JUEGO DE CHAPA EXPULSIÓN CPL. |
| 8 | 32 | 1 | 1 | 1 | 664 108 008 | | AUSWURF BLECHSATZ KPL. | | EXIT CONVEYOR A CPL. | EJECTION CONVOYEUR CPL. | JUEGO DE CHAPA EXPULSIÓN CPL. |
| 8 | 33 | 2 | 2 | 2 | 664 774 373 | | HALTER | | BRACKET | ETRIER | SOPORTE |

TM-92.14 (2009), TM-92.14 H
(2009), TM-92.14 H2 (2009)

9

SCHNEIDWERKZEUG (2)
CUTTING PLATE (2)
PLATEAU DE COUPE (2)
HERRAMIENTA DE CORTE (2)

DOLMAR



A member of the *Takita* Group

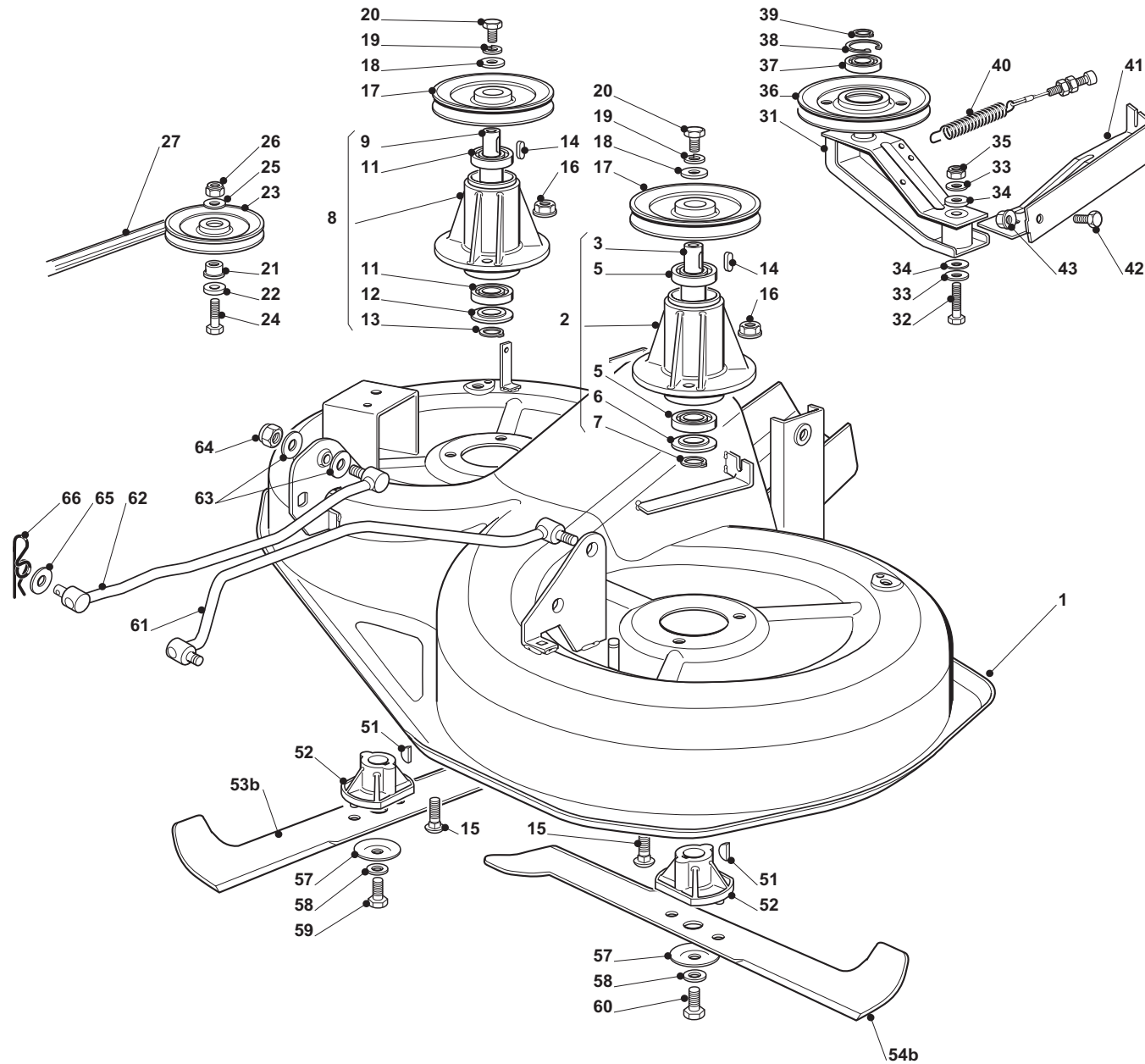

TM-92.14 (2009), TM-92.14 H
(2009), TM-92.14 H2 (2009)

9

SCHNEIDWERKZEUG (2)
CUTTING PLATE (2)
PLATEAU DE COUPE (2)
HERRAMIENTA DE CORTE (2)

DOLMAR
A member of the **Takita** Group

| Seite / Page | Pos. | TM-92.14 (2009) | TM-92.14 H (2009) | TM-92.14 H2 (2009) | Teil-Nr. Part No. No. de pièce No. de pieza | Hinweise Notes Renseign. Nota | Bezeichnung | Spezifikation Specification | Description | Désignation | Denominación |
|--------------|------|-----------------|-------------------|--------------------|--|--|--------------------|--------------------------------|-----------------------|------------------------|-------------------------|
| 9 | 1 | 1 | 1 | 1 | 664 564 075 | | MESSERTROMMEL | | PLATE | PLATEAU | PLANCHA |
| 9 | 2 | 1 | 1 | 1 | 664 207 202 | | NABE LINKS KPL. | | FLANGE ASS.Y | BRIDE CPL. | BRIDA CPL. |
| 9 | 3 | 1 | 1 | 1 | 664 020 802 | | WELLE | | SHAFT | ARBRE | ÁRBOL |
| 9 | 5 | 2 | 2 | 2 | 664 216 047 | | KUGELLAGER | | BALL BEARING | ROULEMENT À BILLES | RODAMIENTO DE BOLAS |
| 9 | 6 | 1 | 1 | 1 | 664 160 501 | | STAUBSCHUTZSCHEIBE | | DUST COVER | PROTEGE-POUSSIÈRE | CUBIERTA GUARDAPOLVO |
| 9 | 7 | 1 | 1 | 1 | 664 609 260 | | SICHERUNGSRING | | RETAINING RING | ANNEAU DE SÛRETÉ | ANILLO DE SEGURIDAD |
| 9 | 8 | 1 | 1 | 1 | 664 207 203 | | NABE RECHTS KPL. | | FLANGE ASS.Y | BRIDE CPL. | BRIDA CPL. |
| 9 | 9 | 1 | 1 | 1 | 664 020 803 | | WELLE | | SHAFT | ARBRE | ÁRBOL |
| 9 | 11 | 2 | 2 | 2 | 664 216 047 | | KUGELLAGER | | BALL BEARING | ROULEMENT À BILLES | RODAMIENTO DE BOLAS |
| 9 | 12 | 1 | 1 | 1 | 664 160 501 | | STAUBSCHUTZSCHEIBE | | DUST COVER | PROTEGE-POUSSIÈRE | CUBIERTA GUARDAPOLVO |
| 9 | 13 | 1 | 1 | 1 | 664 609 260 | | SICHERUNGSRING | | RETAINING RING | ANNEAU DE SÛRETÉ | ANILLO DE SEGURIDAD |
| 9 | 14 | 2 | 2 | 2 | 664 139 480 | | KEIL | | KEY | CLAVETTE | CHAVETA |
| 9 | 15 | 6 | 6 | 6 | 664 818 700 | | SCHRAUBE | | SCREW | VIS | TORNILLO |
| 9 | 16 | 6 | 6 | 6 | 664 154 210 | | MUTTER | | NUT | ECROU | TUERCA |
| 9 | 17 | 2 | 2 | 2 | 664 601 563 | | RIEMENSCHLEIBE | | PULLEY | POULIE | POLEA |
| 9 | 18 | 2 | 2 | 2 | 664 670 007 | | SCHEIBE | | WASHER | RONDELLE | ARANDELA |
| 9 | 19 | 2 | 2 | 2 | 664 583 500 | | FEDERING | | GROWER | GROWER | ARANDELA ELÁSTICA |
| 9 | 20 | 2 | 2 | 2 | 664 793 102 | | SCHRAUBE | | SCREW | VIS | TORNILLO |
| 9 | 21 | 1 | 1 | 1 | 664 160 007 | | DISTANZSTÜCK | | SPACER | ENTRETOISE | SEPARADOR |
| 9 | 22 | 1 | 1 | 1 | 664 670 007 | | SCHEIBE | | WASHER | RONDELLE | ARANDELA |
| 9 | 23 | 1 | 1 | 1 | 664 601 555 | | RIEMENSCHLEIBE | | PULLEY | POULIE | POLEA |
| 9 | 24 | 1 | 1 | 1 | 664 691 115 | | SCHRAUBE | | SCREW | VIS | TORNILLO |
| 9 | 25 | 1 | 1 | 1 | 664 523 060 | | SCHEIBE | | WASHER | RONDELLE | ARANDELA |
| 9 | 26 | 1 | 1 | 1 | 664 155 000 | | MUTTER | | NUT | ECROU | TUERCA |
| 9 | 27 | 1 | 1 | 1 | 664 065 701 | | KEILRIEMEN | | V-BELT | COURROIE TRAPÉZOIDALE | CORREA TRAPEZOIDAL |
| 9 | 31 | 1 | 1 | 1 | 664 318 141 | | HEBEL | | LEVER | LEVIER | PALANCA |
| 9 | 32 | 1 | 1 | 1 | 664 691 700 | | SCHRAUBE | | SCREW | VIS | TORNILLO |
| 9 | 33 | 2 | 2 | 2 | 664 523 070 | | SCHEIBE | | WASHER | RONDELLE | ARANDELA |
| 9 | 34 | 2 | 2 | 2 | 664 672 152 | | SCHEIBE | | WASHER | RONDELLE | ARANDELA |
| 9 | 35 | 1 | 1 | 1 | 664 155 000 | | MUTTER | | NUT | ECROU | TUERCA |
| 9 | 36 | 1 | 1 | 1 | 664 601 564 | | RIEMENSCHLEIBE | | PULLEY | POULIE | POLEA |
| 9 | 37 | 1 | 1 | 1 | 664 216 033 | | KUGELLAGER | | BEARING | ROULEMENT | RODAMIENTO |
| 9 | 38 | 1 | 1 | 1 | 664 610 800 | | SPRENGRING | | SNAP RING | ANNEAU RESSORT | ANILLO DE SUJECIÓN |
| 9 | 39 | 1 | 1 | 1 | 664 609 200 | | SICHERUNGSRING | | RETAINING RING | ANNEAU DE SÛRETÉ | ANILLO DE SEGURIDAD |
| 9 | 40 | 1 | 1 | 1 | 664 004 618 | | KABEL | | CABLE | CÂBLE | CABLE |
| 9 | 41 | 1 | 1 | 1 | 664 774 215 | | ANBINDUNGSBLECH | | BRACKET | TÔLE DE RATTACHAGE | CHAPA DE CONEXIÓN |
| 9 | 42 | 1 | 1 | 1 | 664 792 611 | | SCHRAUBE | | SCREW | VIS | TORNILLO |
| 9 | 43 | 1 | 1 | 1 | 664 293 201 | | MUTTER | | NUT | ECROU | TUERCA |
| 9 | 51 | 2 | 2 | 2 | 664 139 100 | | KEIL | | KEY | CLAVETTE | CHAVETA |
| 9 | 52 | 2 | 2 | 2 | 664 463 200 | | MESSERHALTER | | BLADE HUB | MOYEU LAME | SOPORTE DE LA CUCHILLA |
| 9 | 53b | 1 | 1 | 1 | 664 004 345 | | FANGMESSER RECHTS | | BLADE (COLLECT) RIGHT | LAME DROIT | CUCHILLA DER. |
| 9 | 54b | 1 | 1 | 1 | 664 004 344 | | FANGMESSER LINKS | | BLADE (COLLECT) LEFT | AILETTE DE LAME GAUCHE | ALA DE LA CUCHILLA IZQ. |

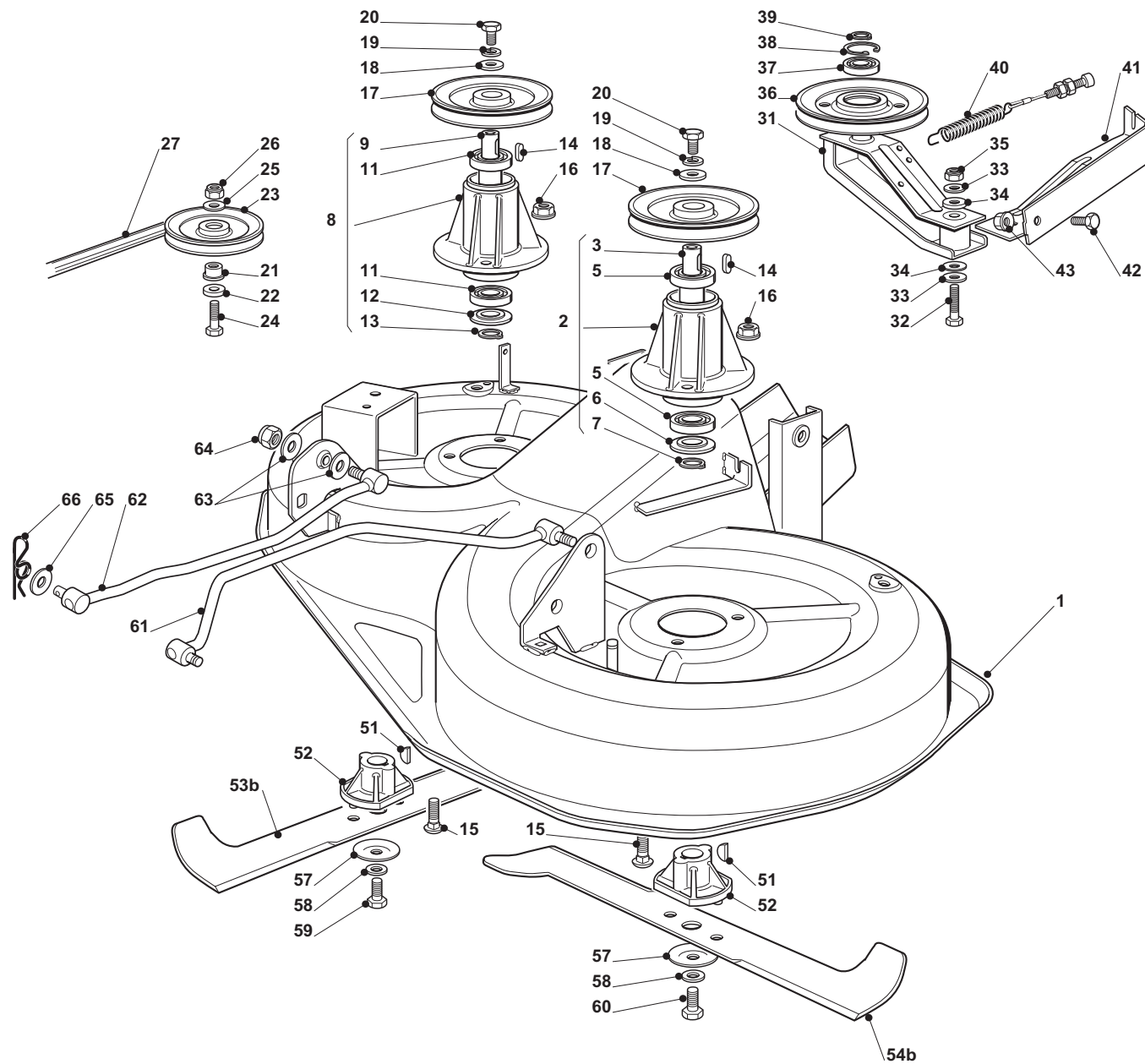

TM-92.14 (2009), TM-92.14 H
(2009), TM-92.14 H2 (2009)

9

SCHNEIDWERKZEUG (2)
CUTTING PLATE (2)
PLATEAU DE COUPE (2)
HERRAMIENTA DE CORTE (2)

DOLMAR
A member of the **Takita** Group

| Seite / Page | Pos. | TM-92.14 (2009) | TM-92.14 H (2009) | TM-92.14 H2 (2009) | Teil-Nr. Part No. No. de pièce No. de pieza | Hinweise Notes Renseign. Nota | Bezeichnung | Spezifikation Specification | Description | Désignation | Denominación |
|--------------|------|-----------------|-------------------|--------------------|--|--|--------------|--------------------------------|----------------|--------------------|--------------------|
| 9 | 57 | 2 | 2 | 2 | 664 160 400 | | FEDERSCHEIBE | | ELASTIC WASHER | RONDELLE ELASTIQUE | ARANDELA ELÁSTICA |
| 9 | 58 | 2 | 2 | 2 | 664 523 080 | | SCHEIBE | | WASHER | RONDELLE | ARANDELA |
| 9 | 59 | 1 | 1 | 1 | 664 735 695 | | SCHRAUBE | | SCREW | VIS | TORNILLO |
| 9 | 60 | 1 | 1 | 1 | 664 735 694 | | SCHRAUBE | | SCREW | VIS | TORNILLO |
| 9 | 61 | 1 | 1 | 1 | 664 000 535 | | KIPPHEBEL | | EQUALIZER | BALANCIER | PALANCA BASCULANTE |
| 9 | 62 | 1 | 1 | 1 | 664 000 533 | | KIPPHEBEL | | EQUALIZER | BALANCIER | PALANCA BASCULANTE |
| 9 | 63 | 4 | 4 | 4 | 664 670 008 | | SCHEIBE | | WASHER | RONDELLE | ARANDELA |
| 9 | 64 | 2 | 2 | 2 | 664 156 602 | | MUTTER | | NUT | ECROU | TUERCA |
| 9 | 65 | 2 | 2 | 2 | 664 670 008 | | SCHEIBE | | WASHER | RONDELLE | ARANDELA |
| 9 | 66 | 2 | 2 | 2 | 664 487 997 | | SPLINT | | COTTER PIN | GOUPILLE | PASADOR |

TM-92.14 (2009), TM-92.14 H
(2009), TM-92.14 H2 (2009)

10

GRASS-SACK
GRASSCATCHER
BAC
CESTO

DOLMAR

A member of the *Takita* Group

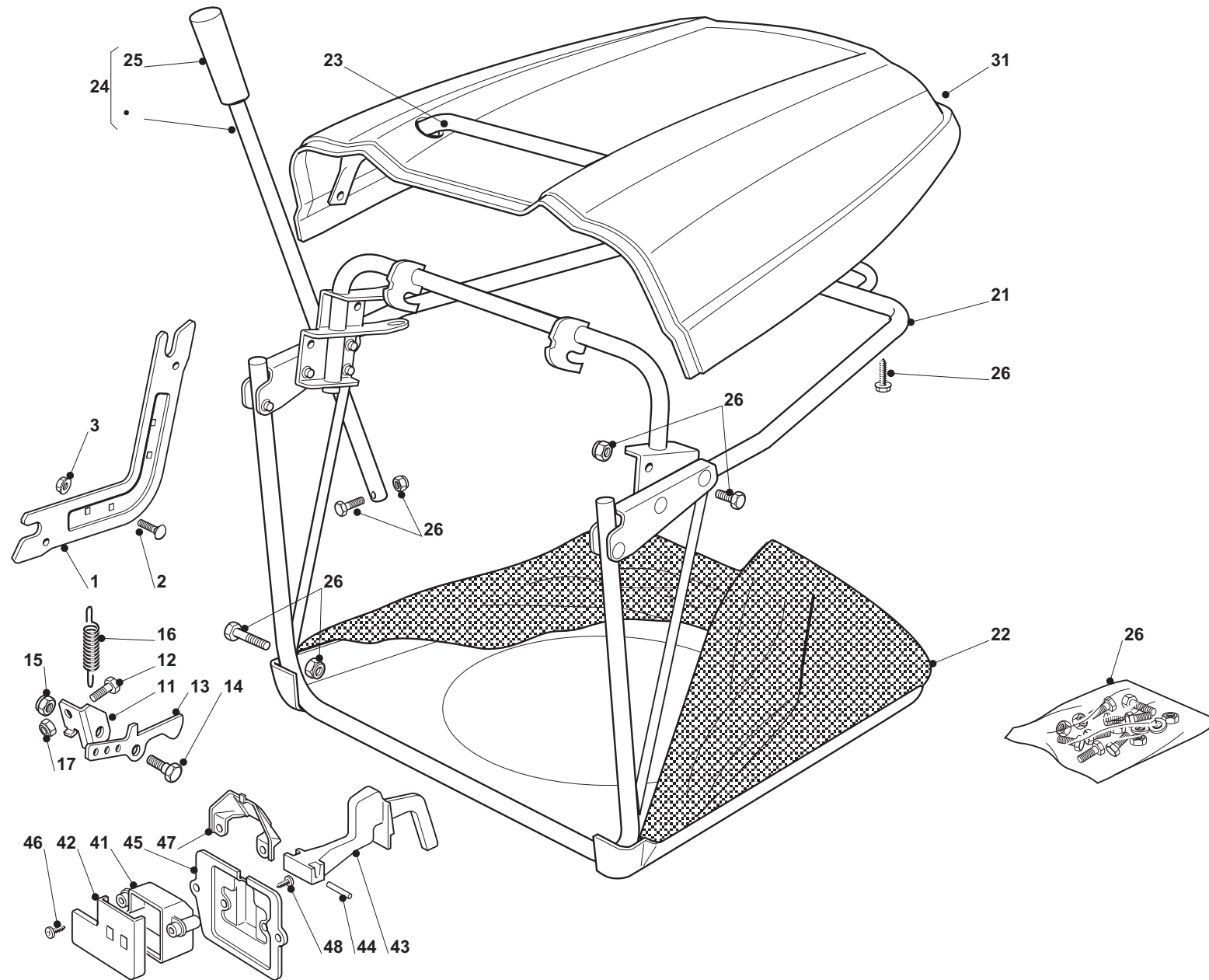

TM-92.14 (2009), TM-92.14 H
(2009), TM-92.14 H2 (2009)

10

GRASS-SACK
GRASSCATCHER
BAC
CESTO

DOLMAR

A member of the **Takita** Group

| Seite / Page | Pos. | TM-92.14 (2009) | TM-92.14 H (2009) | TM-92.14 H2 (2009) | Teil-Nr. Part No. No. de pièce No. de pieza | Hinweise Notes Renseign. Nota | Bezeichnung | Spezifikation Specification | Description | Désignation | Denominación |
|--------------|------|-----------------|-------------------|--------------------|--|--|---------------------|--------------------------------|------------------|----------------------|------------------------|
| 10 | 1 | 2 | 2 | 2 | 664 785 275 | | HALTER | | SUPPORT | SUPPORT | SOPORTE |
| 10 | 2 | 4 | 4 | 4 | 664 818 690 | | SCHRAUBE | | SCREW | VIS | TORNILLO |
| 10 | 3 | 4 | 4 | 4 | 664 293 201 | | MUTTER | | NUT | ECROU | TUERCA |
| 10 | 11 | 1 | 1 | 1 | 664 755 031 | | WINKEL | | BRACKET | SUPPORT | SOPORTE |
| 10 | 12 | 1 | 1 | 1 | 664 789 000 | | SCHRAUBE | | SCREW | VIS | TORNILLO |
| 10 | 13 | 1 | 1 | 1 | 664 774 315 | | HALTER | | BRACKET | ETRIER | SOPORTE |
| 10 | 14 | 1 | 1 | 1 | 664 510 080 | | BOLZEN | | PIN | PIVOT | PIVOTE |
| 10 | 15 | 1 | 1 | 1 | 664 292 102 | | MUTTER | | NUT | ECROU | TUERCA |
| 10 | 16 | 1 | 1 | 1 | 664 450 432 | | FEDER | | SPRING | RESSORT | RESORTE |
| 10 | 17 | 1 | 1 | 1 | 664 154 330 | | MUTTER | | NUT | ECROU | TUERCA |
| 10 | 21 | 1 | 1 | 1 | 664 800 111 | | VORDERRAHMEN | | FRONT FRAME | CHASSIS ANTÉRIEUR | CHASIS |
| 10 | 22 | 1 | 1 | 1 | 664 105 973 | | GRASS-SACK | | GRASS CATCHER | BAC | CESTO |
| 10 | 23 | 1 | 1 | 1 | 664 998 003 | | VORDERGRIFF | | HANDLE | POIGNEE | MANETA |
| 10 | 24 | 1 | 1 | 1 | 664 869 023 | | STANGE | | ROD | BARRE | BARRA |
| 10 | 25 | 1 | 1 | 1 | 664 999 005 | | GRIFF | | HANDLE | POINGEE | MANGO |
| 10 | 26 | 1 | 1 | 1 | 664 180 048 | | SCHRAUBENAUSRÜSTUNG | | SCREWS OUTFIT | ENSEMBLE DES VIS | JUEGO DE TORNILLOS |
| 10 | 31 | 1 | 1 | 1 | 664 110 328 | | HAUBE, ROT | | COVER, RED | COUVRE-BAC, ROUGE | CUBIERTA |
| 10 | 41 | 1 | 1 | 1 | 664 600 041 | | SCHUTZ | | PROTECTION | PROTECTION | PROTECCIÓN |
| 10 | 42 | 1 | 1 | 1 | 664 600 042 | | SCHUTZDECKEL | | PROTECTION COVER | COUVERCLE PROTECTION | CUBIERTA PROTECTORA |
| 10 | 43 | 1 | 1 | 1 | 664 318 124 | | HEBEL | | LEVER | LEVIER | PALANCA |
| 10 | 44 | 1 | 1 | 1 | 664 400 030 | | BOLZEN | | PIN | PIVOT | PIVOTE |
| 10 | 45 | 1 | 1 | 1 | 664 785 272 | | SCHUTZ | | PROTECTION | PROTECTION | PROTECCIÓN |
| 10 | 46 | 1 | 1 | 1 | 664 728 510 | | SCHRAUBE | | SCREW | VIS | TORNILLO |
| 10 | 47 | 1 | 1 | 1 | 664 600 048 | | ABWEISERDECKEL | | DEFLECTOR COVER | COUVERCLE DEFLECTEUR | CUBIERTA DEL DEFLECTOR |
| 10 | 48 | 2 | 2 | 2 | 664 735 110 | | SCHRAUBE | | SCREW | VIS | TORNILLO |

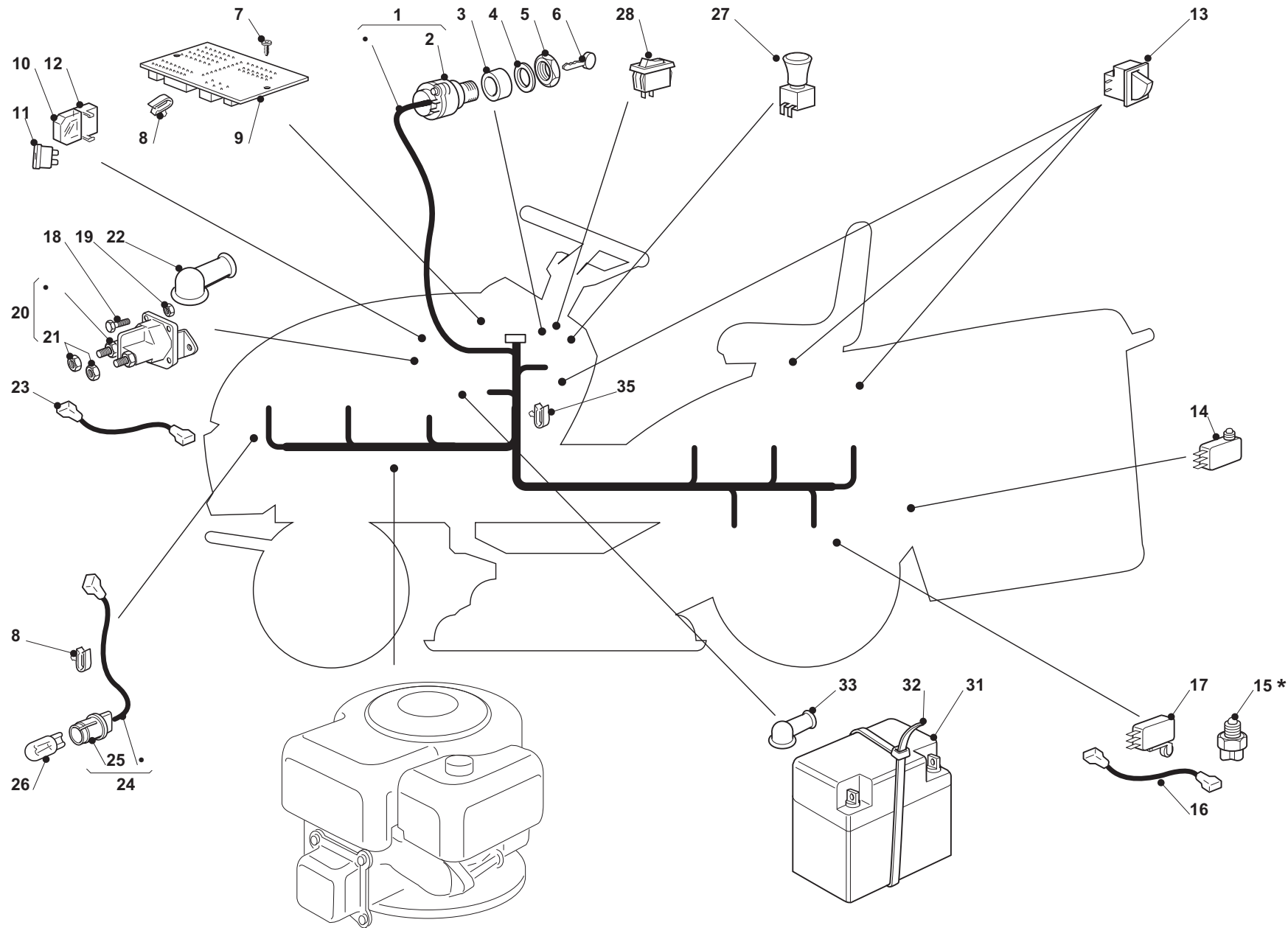

| Seite / Page | Pos. | TM-92.14 (2009) | TM-92.14 H (2009) | Teil-Nr. Part No. No. de pièce No. de pieza | Hinweise Notes Renseign. Nota | Bezeichnung | Spezifikation Specification | Description | Désignation | Denominación |
|--------------|------|-----------------|-------------------|--|--|---|--------------------------------|--|---|---|
| 11 | * | x | | | | ZUM AUSTAUSCH DER MIT «*» GEKENNZEICHNETEN TEILE, WENDEN SIE SICH AN DEN KUNDENDIENST DES MOTORHERSTELLERS. | | TO REPLACE THE PARTS MARKED «*» SEEK ASSISTANCE FROM THE ENGINE MANUFACTURER'S AFTER SALES SERVICE. | POUR LE REMPLACEMENT DES PIÈCES MARQUÉES AVEC «*» S'ADRESSER AU SERVICE APRÈS VENTES DU CONSTRUCTEUR DU MOTEUR. | PARA RECAMBIO DE LAS PIEZAS MARCADO CON <<*>> FAVOR SE DIRIGEN AL SERVICIO TÉCNICO DEL FABRICANTE DEL MOTOR. |
| 11 | 1 | 1 | 1 | 664 040 143 | | KABELSATZ | | CABLES | CABLAGES | CABLEADO |
| 11 | 2 | 1 | 1 | 664 450 072 | | SCHALTER | | STARTING SWITCH | INTERRUPTEUR DEMARRAGE | INTERRUPTOR DE ENCENDIDO |
| 11 | 3 | 1 | 1 | 664 550 136 | | DISTANZRING | | SPACER | ENTRETOISE | SEPARADOR |
| 11 | 4 | 1 | 1 | 664 550 135 | | SCHEIBE | | WASHER | RONDELLE | ARANDELA |
| 11 | 5 | 1 | 1 | 664 400 862 | | NUTMUTTER | | RING NUT | EMBOUT | TUERCA RANURADA |
| 11 | 6 | 1 | 1 | 664 210 022 | | SCHLÜSSEL FÜR START | | STARTING KEY | CLEF A DEMARRAGE | LLAVE DE ENCENDIDO |
| 11 | 7 | 3 | 3 | 664 727 810 | | SCHRAUBE | | SCREW | VIS | TORNILLO |
| 11 | 8 | 2 | 2 | 664 320 506 | | KABELBEFESTIGUNG | | FAIRLEAD | FIXATION CABLE | SUJETACABLE |
| 11 | 9 | 1 | 1 | 664 722 431 | | ELEKTRONISCHE KARTE | | ELECTRONIC CARD | CARTE ELECTRONIQUE | TARJETA ELECTRÓNICA |
| 11 | 10 | 2 | 2 | 664 215 000 | | DECKEL | | COVER | COUVERCLE | CUBIERTA |
| 11 | 11 | 1 | 1 | 664 340 040 | | SICHERUNG | | FUSE | FUSIBLE | FUSIBLE |
| 11 | 11 | 1 | 1 | 664 340 036 | | SICHERUNG | | FUSE | FUSIBLE | FUSIBLE |
| 11 | 12 | 2 | 2 | 664 500 007 | | SICHERUNGHALTER | | FUSE CARRIER | TABLEAU DE FUSIBLE | SOPORTE |
| 11 | 13 | 3 | 3 | 664 410 606 | | MIKROSCHALTER | | MICROSWITCH | MICROINTERRUPTEUR | MICROINTERRUPTOR |
| 11 | 14 | 1 | 1 | 664 410 605 | | FÜLLHÖHENSCHALTER | | FULL GRASS CATCHER MICRO | MICRO BAC PLEIN | MICRO. CESTO LLENO |
| 11 | 15 | 1 | | | | MIKROSCHALTER LEERLAUF | | SWITCH | INTERRUPTEUR | INTERRUPTOR |
| 11 | 16 | 1 | | 664 065 026 | | KABEL | | CABLE | CÂBLE | CABLE |
| 11 | 17 | | 1 | 664 410 609 | | MIKROSCHALTER LEERLAUF | | SWITCH | INTERRUPTEUR | INTERRUPTOR |
| 11 | 18 | 2 | 2 | 664 791 213 | | SCHRAUBE | | SCREW | VIS | TORNILLO |
| 11 | 19 | 2 | 2 | 664 292 102 | | MUTTER | | NUT | ECROU | TUERCA |
| 11 | 20 | 1 | 1 | 664 736 110 | | ANLASSRELAIS | | STARTER RELAY | RELAIS D'ALLUMAGE | RELÉ DE ARRANQUE |
| 11 | 21 | 2 | 2 | 664 360 352 | | MUTTER | | NUT | ECROU | TUERCA |
| 11 | 22 | 1 | 1 | 664 564 864 | | STECKER | | CONNECTOR | CONNECTEUR | FICHA DE CONTACTO |
| 11 | 23 | 1 | 1 | 664 065 017 | | KABEL | | CABLE | CÂBLE | CABLE |
| 11 | 24 | 1 | 1 | 664 040 070 | | KABEL | | CABLE | CÂBLE | CABLE |
| 11 | 25 | 2 | 2 | 664 999 030 | | LAMPENFASSUNG | | LAMP SOCKET | DOUILLE DE LAMPE | PORTALÁMPARAS |
| 11 | 26 | 2 | 2 | 664 459 100 | | LAMPE HALOGEN | | LAMP, HALOGEN | LAMPE HALOGENE | LÁMPARA HALÓGENA |
| 11 | 27 | 1 | 1 | 664 450 068 | | KUPPLUNGSSCHALTER | | CLUTCH SWITCH | INTERRUPTEUR EMBRAJAGE | INTERRUPTOR |
| 11 | 28 | 1 | 1 | 664 450 060 | | LICHTSCHALTER | | SWITCH | INTERRUPTEUR | INTERRUPTOR |
| 11 | 31 | 1 | 1 | 664 120 002 | | BATTERIE | | BATTERY | BATTERIE | BATERÍA |
| 11 | 32 | 1 | 1 | 664 320 028 | | KABELBEFESTIGUNG | | FAIRLEAD | FIXATION CABLE | SUJETACABLE |
| 11 | 33 | 1 | 1 | 664 564 861 | | STECKER | | PROTECTION | CAPUCHON | CAPUCHÓN |
| 11 | 35 | 9 | 9 | 664 320 506 | | KABELBEFESTIGUNG | | FAIRLEAD | FIXATION CABLE | SUJETACABLE |

TM-92.14 (2009), TM-92.14 H
(2009), TM-92.14 H2 (2009)

11a

ELEKTRISCHE TEILE
ELECTRICAL PARTS
PIECES ELECTRIQUES
PARTES ELÉCTRICAS

DOLMAR
A member of the *Takita* Group

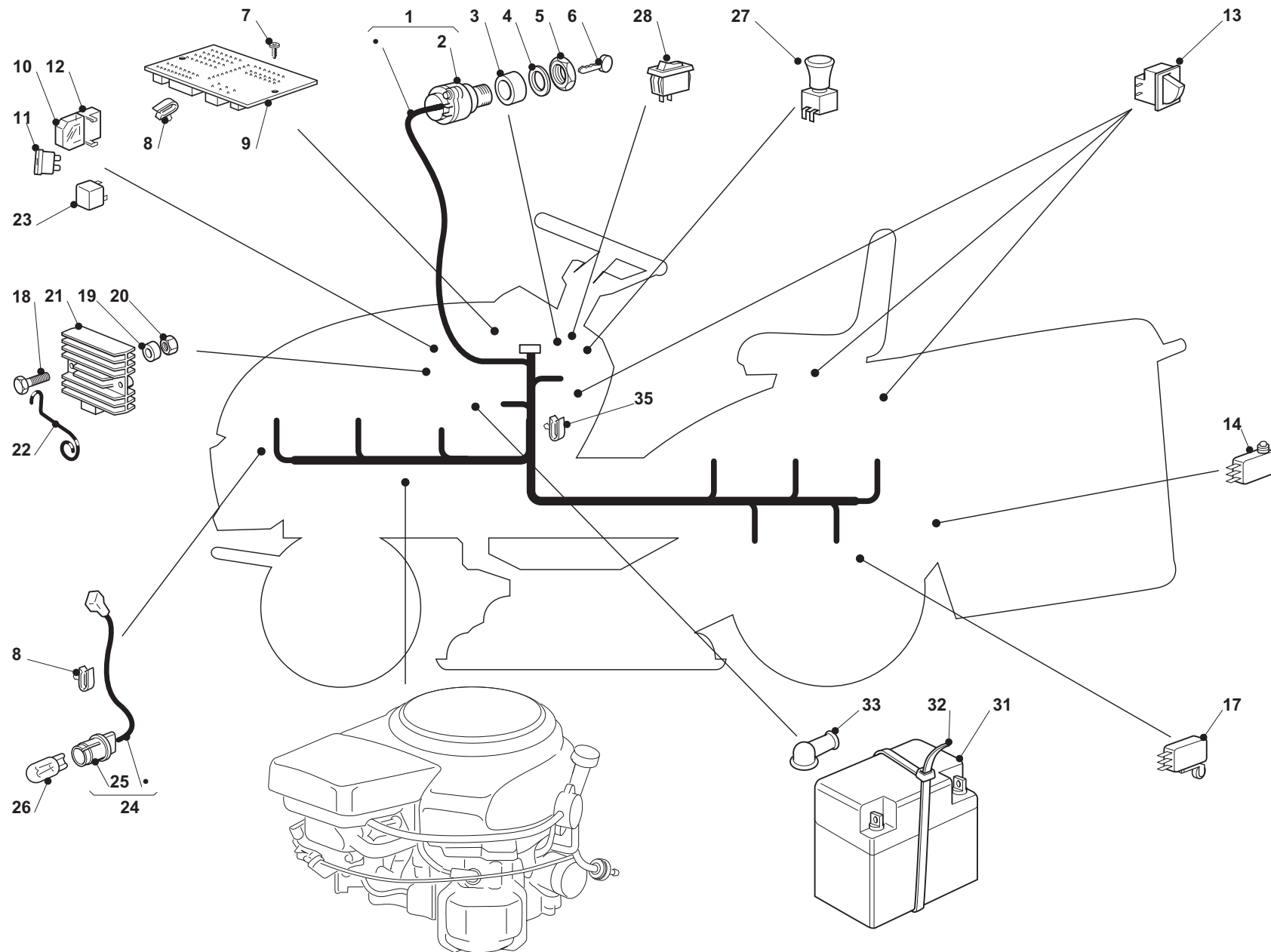

TM-92.14 (2009), TM-92.14 H
(2009), TM-92.14 H2 (2009)

11a

ELEKTRISCHE TEILE
ELECTRICAL PARTS
PIECES ELECTRIQUES
PARTES ELÉCTRICAS

DOLMAR
A member of the **Takita** Group

| Seite / Page | Pos. | Teil-Nr. Part No. No. de pièce No. de pieza | Hinweise Notes Renseign. Nota | Bezeichnung | Spezifikation Specification | Description | Désignation | Denominación |
|--------------|------|--|--|--|--------------------------------|--|---|---|
| 11a* | x | | | ZUM AUSTAUSCH DER MIT «*» GEKENNZEICHNETEN TEILE, WENDEN SIE SICH AN DEN KUNDENDIENST DES MOTORHERSTELLERS. | | TO REPLACE THE PARTS MARKED «*» SEEK ASSISTANCE FROM THE ENGINE MANUFACTURER'S AFTER SALES SERVICE. | POUR LE REMPLACEMENT DES PIÈCES MARQUÉES AVEC «*» S'ADRESSER AU SERVICE APRÈS VENTES DU CONSTRUCTEUR DU MOTEUR. | PARA RECAMBIO DE LAS PIEZAS MARCADO CON «*» FAVOR SE DIRIGEN AL SERVICIO TÉCNICO DEL FABRICANTE DEL MOTOR. |
| 11a1 | 1 | 664 040 144 | | KABELSATZ | | SET OF WIRES | JEU DE CÂBLES | JUEGO DE CABLES |
| 11a2 | 1 | 664 450 072 | | SCHALTER | | STARTING SWITCH | INTERRUPTEUR DEMARRAGE | INTERRUPTOR DE ENCENDIDO |
| 11a3 | 1 | 664 550 136 | | DISTANZRING | | SPACER | ENTRETOISE | SEPARADOR |
| 11a4 | 1 | 664 550 135 | | SCHIBE | | WASHER | RONDELLE | ARANDELA |
| 11a5 | 1 | 664 400 862 | | NUTMÜTTER | | RING NUT | EMBOUT | TUERCA RANURADA |
| 11a6 | 1 | 664 210 022 | | SCHLÜSSEL FÜR START | | STARTING KEY | CLEF A DEMARRAGE | LLAVE DE ENCENDIDO |
| 11a7 | 3 | 664 727 810 | | SCHRAUBE | | SCREW | VIS | TORNILLO |
| 11a8 | 2 | 664 320 506 | | KABELBEFESTIGUNG | | FAIRLEAD | FIXATION CABLE | SUJETACABLE |
| 11a9 | 1 | 664 722 431 | | ELEKTRONISCHE KARTE | | ELECTRONIC CARD | CARTE ELECTRONIQUE | TARJETA ELECTRÓNICA |
| 11a10 | 2 | 664 215 000 | | DECKEL | | COVER | COUVERCLE | CUBIERTA |
| 11a11 | 1 | 664 340 040 | | SICHERUNG | | FUSE | FUSIBLE | FUSIBLE |
| 11a11 | 1 | 664 340 036 | | SICHERUNG | | FUSE | FUSIBLE | FUSIBLE |
| 11a12 | 2 | 664 500 007 | | SICHERUNGHALTER | | FUSE CARRIER | TABLEAU DE FUSIBLE | SOPORTE |
| 11a13 | 3 | 664 410 606 | | MIKROSCHALTER | | MICROSWITCH | MICROINTERRUPTEUR | MICROINTERRUPTOR |
| 11a14 | 1 | 664 410 605 | | FÜLLHÖHENSCHALTER | | FULL GRASS CATCHER MICRO | MICRO BAC PLEIN | MICRO. CESTO LLENO |
| 11a17 | 1 | 664 410 609 | | MIKROSCHALTER LEERLAUF | | SWITCH | INTERRUPTEUR | INTERRUPTOR |
| 11a18 | 2 | 664 815 221 | | SCHRAUBE | | SCREW | VIS | TORNILLO |
| 11a19 | 2 | 664 170 950 | | DISTANZSTÜCK | | SPACER | PIÈCE DISTANCE | SEPARADOR |
| 11a20 | 2 | 664 292 102 | | MUTTER | | NUT | ECROU | TUERCA |
| 11a21* | 1 | | | ANLASSRELAIS | | STARTER RELAY | RELAIS D'ALLUMAGE | RELÉ DE ARRANQUE |
| 11a22 | 1 | 664 430 561 | | FEDER | | SPRING | RESSORT | MUELLE |
| 11a23 | 1 | 664 567 000 | | RELAIS | | RELAY | RELAIS | RELEVADOR |
| 11a24 | 1 | 664 040 070 | | KABEL | | CABLE | CÂBLE | CABLE |
| 11a25 | 2 | 664 999 030 | | LAMPENFASSUNG | | LAMP SOCKET | DOUILLE DE LAMPE | PORTALÁMPARAS |
| 11a26 | 2 | 664 459 100 | | LAMPE HALOGEN | | LAMP, HALOGEN | LAMPE HALOGÈNE | LÁMPARA HALÓGENA |
| 11a27 | 1 | 664 450 068 | | KUPPLUNGSSCHALTER | | CLUTCH SWITCH | INTERRUPTEUR EMBRAJAGE | INTERRUPTOR |
| 11a28 | 1 | 664 450 060 | | LICHTSCHALTER | | SWITCH | INTERRUPTEUR | INTERRUPTOR |
| 11a31 | 1 | 664 120 002 | | BATTERIE | | BATTERY | BATTERIE | BATERÍA |
| 11a32 | 1 | 664 320 028 | | KABELBEFESTIGUNG | | FAIRLEAD | FIXATION CABLE | SUJETACABLE |
| 11a33 | 1 | 664 564 861 | | STECKER | | PROTECTION | CAPUCHON | CAPUCHÓN |
| 11a35 | 9 | 664 320 506 | | KABELBEFESTIGUNG | | FAIRLEAD | FIXATION CABLE | SUJETACABLE |

TM-92.14 (2009), TM-92.14 H
(2009), TM-92.14 H2 (2009)

12

ZUBEHÖR NACH ANFRAGE
OPTIONALS ON REQUEST
ACCESSOIRES SUR DEMANDE
ACCESORIO BAJO DEMANDA

DOLMAR



A member of the **Trakita** Group

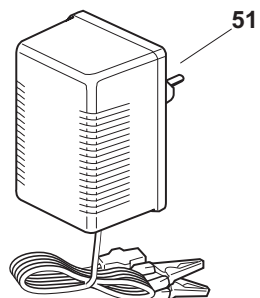
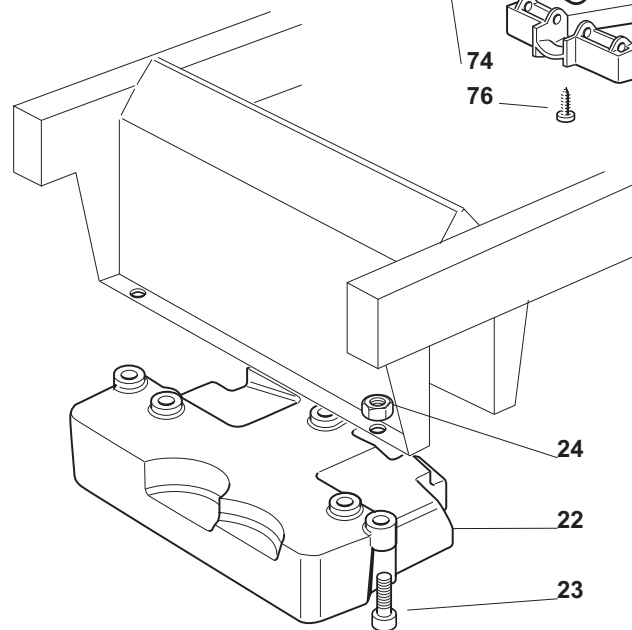
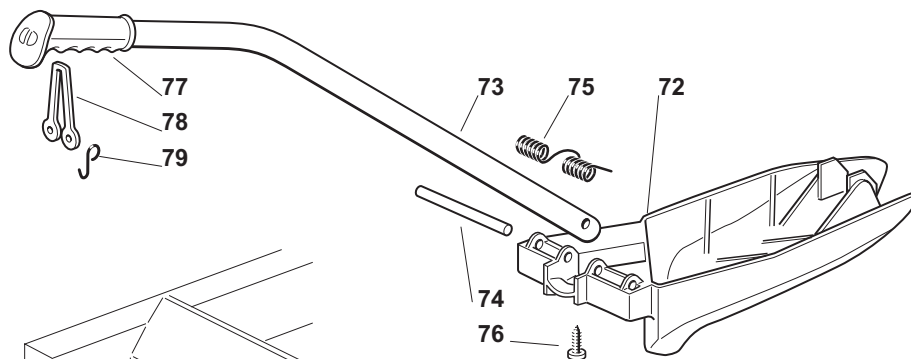
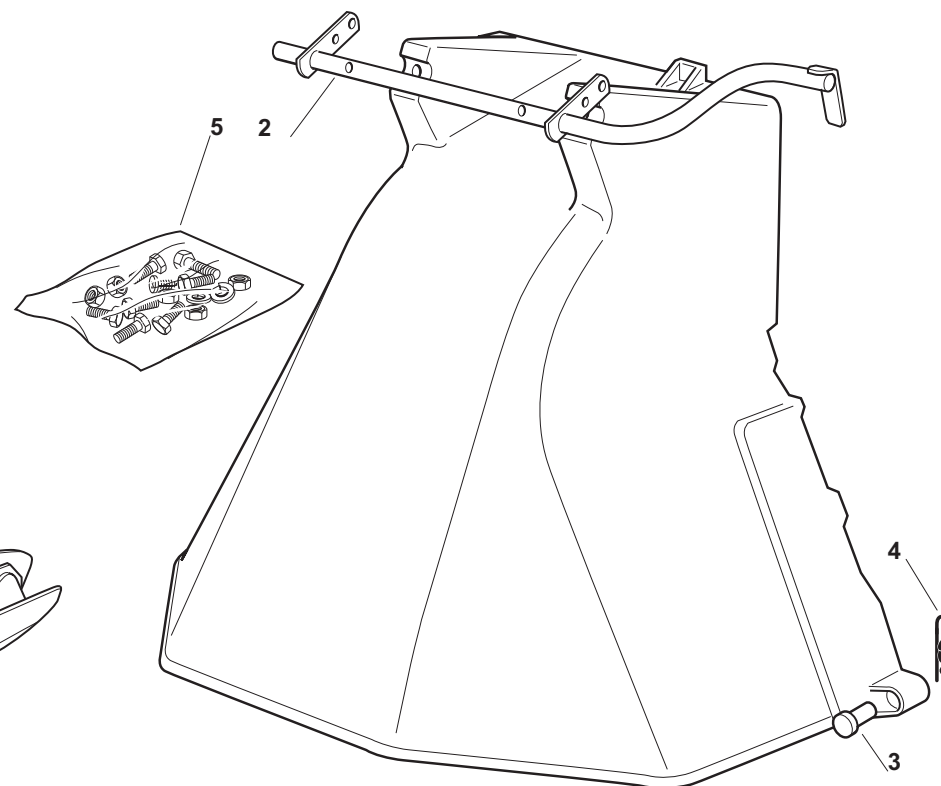
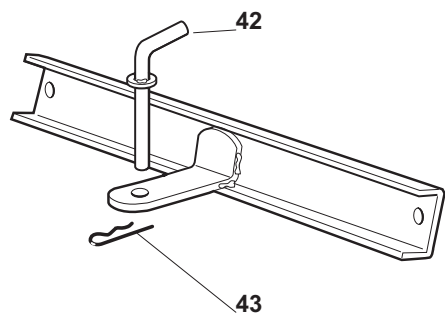

TM-92.14 (2009), TM-92.14 H
(2009), TM-92.14 H2 (2009)

12

ZUBEHÖR NACH ANFRAGE
OPTIONALS ON REQUEST
ACCESSOIRES SUR DEMANDE
ACCESORIO BAJO DEMANDA

DOLMAR
A member of the **Takita** Group

| Seite / Page | Pos. | TM-92.14 (2009) | TM-92.14 H (2009) | TM-92.14 H2 (2009) | Teil-Nr. Part No. No. de pièce No. de pieza | Hinweise Notes Renseign. Nota | Bezeichnung | Spezifikation Specification | Description | Désignation | Denominación |
|--------------|------|-----------------|-------------------|--------------------|--|--|---------------------|--------------------------------|-----------------|-----------------------|----------------------|
| 12 | 2 | 1 | 1 | 1 | 664 999 035 | | HALTER | | SUPPORT | SOPPORT | SOPORTE |
| 12 | 3 | 2 | 2 | 2 | 664 510 022 | | BOLZEN | | PIN | PIVOT | PIVOTE |
| 12 | 4 | 2 | 2 | 2 | 664 487 997 | | SPLINT | | COTTER PIN | GOUPILLE | PASADOR |
| 12 | 5 | 1 | 1 | 1 | 664 180 062 | | SCHRAUBENAUSRÜSTUNG | | SCREWS OUTFIT | ENSEMBLE DES VIS | JUEGO DE TORNILLOS |
| 12 | 22 | 1 | 1 | 1 | 664 519 997 | | GEWICHT | | WEIGHT | POIDS | PESO |
| 12 | 23 | 3 | 3 | 3 | 664 760 520 | | SCHRAUBE | | SCREW | VIS | TORNILLO |
| 12 | 24 | 3 | 3 | 3 | 664 155 000 | | MUTTER | | NUT | ECROU | TUERCA |
| 12 | 42 | 1 | 1 | 1 | 664 510 021 | | BOLZEN | | PIN | PIVOT | PIVOTE |
| 12 | 43 | 1 | 1 | 1 | 664 487 999 | | SPLINT | | COTTER PIN | GOUPILLE | PASADOR |
| 12 | 51 | 1 | 1 | 1 | 664 180 052 | | BATTERIELADEGERÄT | UK | BATTERY CHARGER | CHARGEUR DE BATTERIES | CARGADOR DE BATERÍAS |
| 12 | 51 | 1 | 1 | 1 | 664 180 050 | | BATTERIELADEGERÄT | DE | BATTERY CHARGER | CHARGEUR DE BATTERIES | CARGADOR DE BATERÍAS |
| 12 | 72 | 1 | 1 | 1 | 664 140 093 | | ABWEISER | | DEFLECTOR | DEFLECTEUR | DEFLECTOR |
| 12 | 73 | 1 | 1 | 1 | 664 394 007 | | STIEL | | HANDLE | GUIDON | MANGO |
| 12 | 74 | 1 | 1 | 1 | 664 510 077 | | BOLZEN | | PIN | PIVOT | PIVOTE |
| 12 | 75 | 1 | 1 | 1 | 664 430 245 | | FEDER | | SPRING | RESSORT | MUELLE |
| 12 | 76 | 1 | 1 | 1 | 664 735 410 | | SCHRAUBE | | SCREW | VIS | TORNILLO |
| 12 | 77 | 1 | 1 | 1 | 664 280 000 | | GRIFF | | HANDGRIP | BRANCHE | MANETA |
| 12 | 78 | 1 | 1 | 1 | 664 840 011 | | GUMMIZUG | | ELASTIC TIE-ROD | TIRANT ELASTIQUE | SENSOR DE GOMA |
| 12 | 79 | 2 | 2 | 2 | 664 253 004 | | HAKEN | | HOOK | CROCHET | GANCHO |

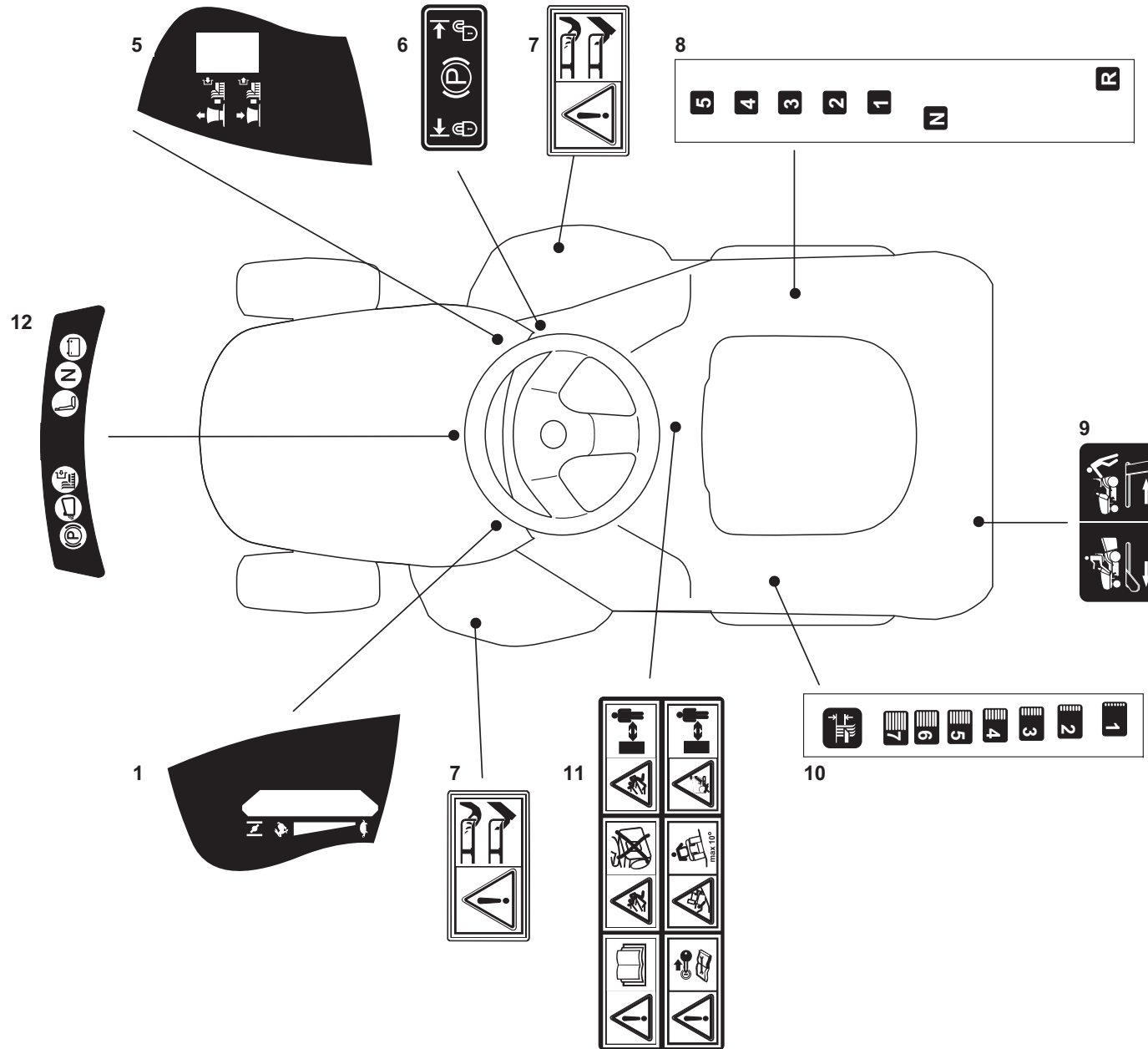

| Seite / Page | Pos. | TM-92.14 (2009) | TM-92.14 H (2009) | TM-92.14 H2 (2009) | Teil-Nr. Part No. No. de pièce No. de pieza | Hinweise Notes Renseign. Nota | Bezeichnung | Spezifikation Specification | Description | Désignation | Denominación |
|--------------|------|-----------------|-------------------|--------------------|--|--|------------------------------------|--------------------------------|----------------------------|-------------------------------------|---------------------------------------|
| 13 | 1 | 1 | 1 | 1 | 664 361 440 | | SCHILD, MOTORFERNBEDIENUNG | | LABEL, THROTTLE | ETIQUETTE, ACCELERATEUR | ETIQUETA, ACELERADOR |
| 13 | 5 | 1 | 1 | 1 | 664 361 439 | | SCHILD, MESSERKUPPLUNG | | LABEL, KNIFE COUPLING | ETIQUETTE, ACCOUPLEMENT DE LAME | ETIQUETA, ACOPLAMIENTO DE LA CUCHILLA |
| 13 | 6 | 1 | 1 | 1 | 664 361 452 | | SCHILD, PARKBREMSE | | LABEL, PARKING BRAKE | ETIQUETTE | ETIQUETA |
| 13 | 7 | 2 | 2 | 2 | 664 356 699 | | SCHILD SICHERHEITSHINWEISE | | LABEL, SAFETY INSTRUCTIONS | ETIQUETTE, INSTRUCTIONS DE SÉCURITÉ | ETIQUETA, SEGURIDAD |
| 13 | 8 | 1 | | | 664 361 447 | | SCHILD, GANGSCHALTUNG | | LABEL, SPEED DRIVE CONTROL | ETIQUETTE, COMM. CHANGEMENT VITESSE | ETIQUETA, CAJA DE CAMBIOS |
| 13 | 9 | | 1 | 1 | 664 361 451 | | SCHILD BEDIENHINWEISE | | LABEL, CAUTION | PLAQUE, DIRECTIVES DE COMMANDE | CALCOMANÍA, INDICACIONES DE MANEJO |
| 13 | 10 | 1 | 1 | 1 | 664 361 441 | | SCHILD, SCHNITTHÖHENVERSTELLUNG | | LABEL, HEIGHT ADJUSTMENT | ETIQUETTE, REGLAGE HAUTEUR | ETIQUETA, AJUSTE ALTURA |
| 13 | 11 | 1 | 1 | 1 | 664 361 553 | | SCHILD SICHERHEITSHINWEISE | | LABEL, SAFETY INSTRUCTIONS | ETIQUETTE, INSTRUCTIONS DE SÉCURITÉ | ETIQUETA, SEGURIDAD |
| 13 | 12 | 1 | 1 | 1 | 664 420 020 | | SCHILD | | LABEL | ETIQUETTE | ETIQUETA |

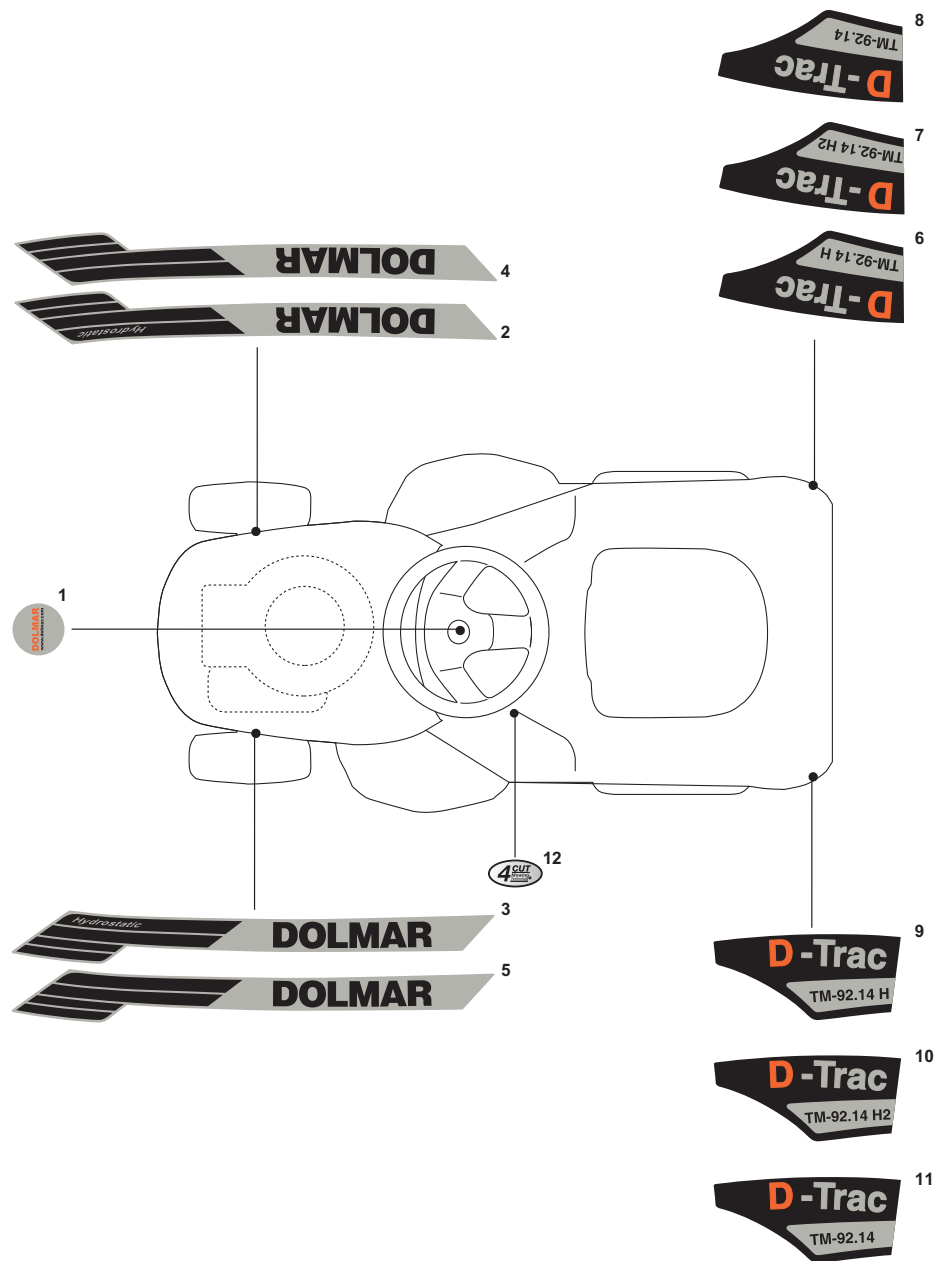

TM-92.14 (2009), TM-92.14 H
(2009), TM-92.14 H2 (2009)

14

AUFKLEBER
LABELS
ETIQUETTES
ETIQUETA

DOLMAR

A member of the **Makita** Group

| Seite / Page | Pos. | TM-92.14 (2009) | TM-92.14 H (2009) | TM-92.14 H2 (2009) | Teil-Nr. Part No. No. de pièce No. de pieza | Hinweise Notes Renseign. Nota | Bezeichnung | Spezifikation Specification | Description | Désignation | Denominación |
|--------------|------|-----------------|-------------------|--------------------|--|--|-------------|--------------------------------|-------------|-------------|--------------|
| 14 | 1 | 1 | 1 | 1 | 664 361 485 | | SCHILD | DOLMAR | LABEL | ETIQUETTE | ETIQUETA |
| 14 | 2 | | 1 | 1 | 664 362 510 | | SCHILD | DOLMAR | LABEL | ETIQUETTE | ETIQUETA |
| 14 | 3 | | 1 | 1 | 664 362 511 | | SCHILD | DOLMAR | LABEL | ETIQUETTE | ETIQUETA |
| 14 | 4 | 1 | | | 664 362 508 | | SCHILD | DOLMAR | LABEL | ETIQUETTE | ETIQUETA |
| 14 | 5 | 1 | | | 664 362 509 | | SCHILD | DOLMAR | LABEL | ETIQUETTE | ETIQUETA |
| 14 | 6 | | 1 | | 664 362 514 | | SCHILD | TM-92.14 H | LABEL | ETIQUETTE | ETIQUETA |
| 14 | 7 | | | 1 | 664 363 139 | | SCHILD | TM-92.14 H2 | LABEL | ETIQUETTE | ETIQUETA |
| 14 | 8 | 1 | | | 664 362 516 | | SCHILD | TM-92.14 | LABEL | ETIQUETTE | ETIQUETA |
| 14 | 9 | | 1 | | 664 362 515 | | SCHILD | TM-92.14 H | LABEL | ETIQUETTE | ETIQUETA |
| 14 | 10 | | | 1 | 664 363 140 | | SCHILD | TM-92.14 H2 | LABEL | ETIQUETTE | ETIQUETA |
| 14 | 11 | 1 | | | 664 362 517 | | SCHILD | TM-92.14 | LABEL | ETIQUETTE | ETIQUETA |
| 14 | 12 | 1 | 1 | 1 | 664 999 576 | | SCHILD | 4 CUT | LABEL | ETIQUETTE | ETIQUETA |

TM-92.14 (2009), TM-92.14 H
(2009), TM-92.14 H2 (2009)

DOLMAR



A member of the **Takita** Group

| | Zeichenerklärung | Key to symbols | Légende | Explicación de símbolos |
|--|--|---|--|--|
| => 1999999 2000000 => 2003.04 => TI 2003/07 Acc. = { m Corr. | Produktion bis Serien-Nr. Neues Teil ab Serien-Nr. Neues Teil ab Jahr / Monat Siehe Technische Information Jahr / Nr. Zubehör (nicht im Lieferumfang) Keine Serienausführung, jedoch verwendbar Beinhaltet Positions-Nr. Meterware Druckfehlerberichtigung | Production to serial number New part from serial number New part from Year / Month See Technical Information Year / No. Accessories (not included in the delivery inventory) No standard execution, may be used Contains item number Sold by the meter Error correction | Production jusqu'à n° de série Nouvelle pièce à partir du n° de série Nouvelle pièce à partir de année / mois Voir information technique année / n° Accessoires (non compris dans la livraison) Aucune exécut. en série, cependant utilisable contient n° de numéro Au mètre Rectification d'erreurs | Producción hasta N° de serie Pieza nueva a partir de N° de serie Pieza nueva a partir de año / mes Véase inform. técnico año / N° Accesorios (no incluido en la extensión del suministro) No es de serie, pero sirve Contiene pos N° Por metro Fe de erratas |
| | Änderungen vorbehalten | Specifications subject to change without notice | Changements sans préavis | Mejoras constructivas sin previo aviso |