

Spare Parts List
Ersatzteilliste
Liste de pièces détachées
Lista de piezas de repuesto

2009-03



(2009)

RM-63.7

DOLMAR



A member of the *Makita* Group

995700310 (D, GB, F, E)

(2009) RM-63.7

1

RAHMENSATZ
CHASSIS
CHASSIS
CHASSIS

DOLMAR
A member of the *Makita* Group

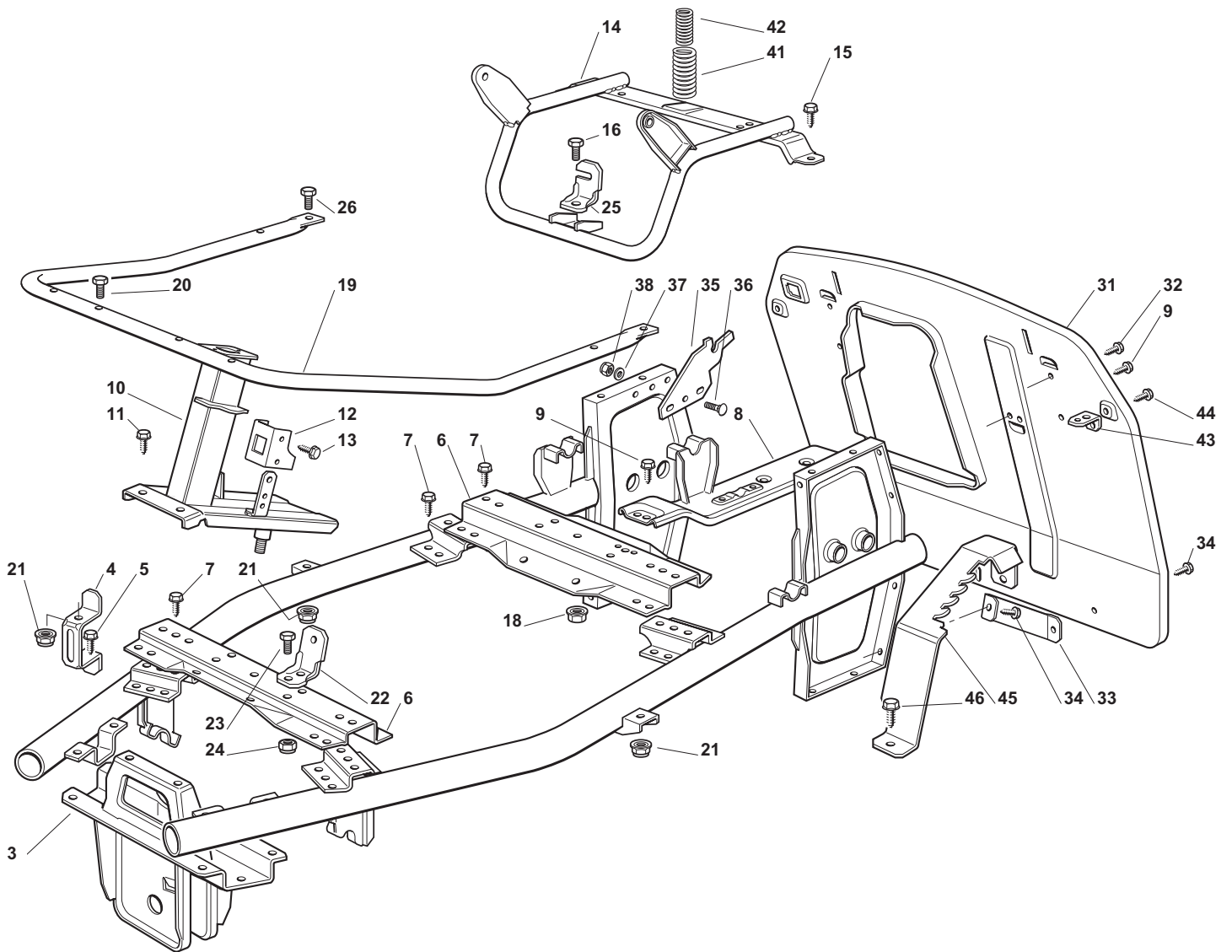

(2009) RM-63.7

1

RAHMENSATZ
CHASSIS
CHASSIS
CHASSIS

DOLMAR
A member of the *Makita* Group

Seite / Page	Pos.	RM-63.7	Teil-Nr. Part No. No. de pièce No. de pieza	Hinweise Notes Renseign. Nota	Bezeichnung	Spezifikation Specification	Description	Désignation	Denominación
1	3	1	664 783 015		HALTER		SUPPORT	SUPPORT	SOPORTE
1	4	2	664 772 121		HALTER		CLAMP	ETRIER	SOPORTE
1	5	6	664 735 121		SCHRAUBE		SCREW	VIS	TORNILLO
1	6	2	664 650 115		VERSTÄRKUNG		STIFFENING	REINFORCEMENT	REFUERZO INFERIOR
1	7	10	664 735 121		SCHRAUBE		SCREW	VIS	TORNILLO
1	8	1	664 560 105		VERSTÄRKUNG		STIFFENING	REINFORCEMENT	REFUERZO INFERIOR
1	9	4	664 735 121		SCHRAUBE		SCREW	VIS	TORNILLO
1	10	1	664 783 037		HALTER		SUPPORT	SUPPORT	SOPORTE
1	11	6	664 735 121		SCHRAUBE		SCREW	VIS	TORNILLO
1	12	1	664 772 095		HALTER		CLAMP	ETRIER	SOPORTE
1	13	2	664 735 105		SCHRAUBE		SCREW	VIS	TORNILLO
1	14	1	664 801 117		HALTER		SUPPORT	SUPPORT	SOPORTE
1	15	2	664 735 121		SCHRAUBE		SCREW	VIS	TORNILLO
1	16	1	664 793 701		SCHRAUBE	M8X30	SCREW	VIS	TORNILLO
1	18	1	664 293 201		MUTTER		NUT	ECROU	TUERCA
1	19	1	664 999 057		HALTER		SUPPORT	SUPPORT	SOPORTE
1	20	2	664 792 099		SCHRAUBE		SCREW	VIS	TORNILLO
1	21	4	664 154 510		MUTTER		NUT	ECROU	TUERCA
1	22	1	664 773 077		WINKEL		BRACKET	SUPPORT	SOPORTE
1	23	1	664 791 011		SCHRAUBE		SCREW	VIS	TORNILLO
1	24	1	664 154 510		MUTTER		NUT	ECROU	TUERCA
1	25	1	664 753 081		WINKEL		BRACKET	SUPPORT	SOPORTE
1	26	2	664 791 500		SCHRAUBE		SCREW	VIS	TORNILLO
1	31	1	664 545 061		PLATTE		PLATE	PLAQUE	PLACA
1	32	4	664 735 121		SCHRAUBE		SCREW	VIS	TORNILLO
1	33	2	664 650 111		VERSTÄRKUNG		STIFFENING	REINFORCEMENT	REFUERZO INFERIOR
1	34	4	664 735 121		SCHRAUBE		SCREW	VIS	TORNILLO
1	35	2	664 772 131		HALTER		CLAMP	ETRIER	SOPORTE
1	36	2	664 818 690		SCHRAUBE		SCREW	VIS	TORNILLO
1	37	2	664 521 350		SCHEIBE		WASHER	RONDELLE	ARANDELA
1	38	2	664 155 000		MUTTER		NUT	ECROU	TUERCA
1	41	1	664 430 567		FEDER		SPRING	RESSORT	MUELLE
1	42	1	664 430 569		FEDER		SPRING	RESSORT	MUELLE
1	43	2	664 753 073		WINKEL		BRACKET	SUPPORT	SOPORTE
1	44	2	664 729 600		SCHRAUBE		SCREW	VIS	TORNILLO
1	45	1	664 734 059		ZAHNSCHIENE		RACK	CREMAILLERE	CREMALLERA
1	46	2	664 735 121		SCHRAUBE		SCREW	VIS	TORNILLO

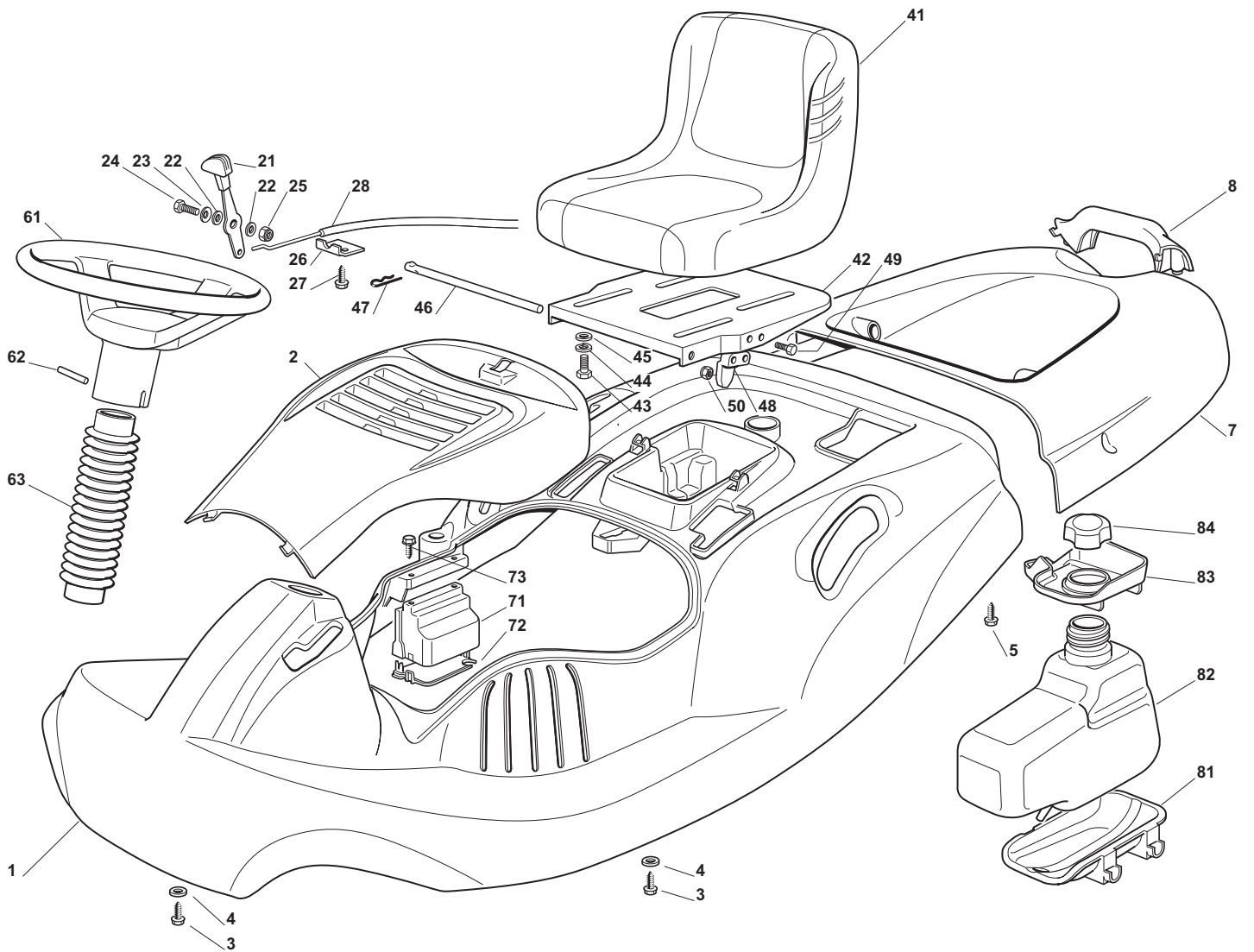

Seite / Page	Pos.	RM-63.7	Teil-Nr. Part No. No. de pièce No. de pieza	Hinweise Notes Renseign. Nota	Bezeichnung	Spezifikation Specification	Description	Désignation	Denominación
2	1	1	664 110 375		RADABDECKUNG, ROT		COVER, RED	COUVERCLE, ROUGE	CONSOLA, ROJO
2	2	1	664 110 376		MOTORHAUBE, ROT		MOTOR DECK, RED	CAPOT, ROUGE	CUBIERTA DEL MOTOR, ROJO
2	3	4	664 735 410		SCHRAUBE		SCREW	VIS	TORNILLO
2	4	4	664 523 040		SCHEIBE		WASHER	RONDELLE	ARANDELA
2	5	2	664 735 402		SCHRAUBE		SCREW	VIS	TORNILLO
2	7	1	664 110 377		HAUBE, ROT		COVER, RED	COUVRE-BAC, ROUGE	CUBIERTA, ROJO
2	8	1	664 394 000		GRIFF		HANDLE	POIGNEE	MANETA
2	21	1	664 007 280		GASHEBEL		THROTTLE	ACCÉLÉRATEUR	ACELERADOR
2	22	2	664 523 040		SCHEIBE		WASHER	RONDELLE	ARANDELA
2	23	1	664 530 060		SCHEIBE		WASHER	RONDELLE	ARANDELA
2	24	1	664 791 500		SCHRAUBE		SCREW	VIS	TORNILLO
2	25	1	664 154 510		MUTTER		NUT	ECROU	TUERCA
2	26	1	664 981 467		PLATTE		PLATE	PLAQUE	PLACA
2	27	2	664 735 105		SCHRAUBE		SCREW	VIS	TORNILLO
2	28	1	664 000 252		GASZUG		BOWDEN CABLE	CÂBLE BOWDEN	TRACCIÓN BOWDEN
2	41	1	664 722 463		SITZ		SEAT	SIEGE	ASIENTO
2	42	1	664 546 039		HALTER		SUPPORT	SUPPORT	SOPORTE
2	43	4	664 793 101		SCHRAUBE		SCREW	VIS	TORNILLO
2	44	4	664 583 500		FEDERRING		GROWER	GROWER	ARANDELA ELÁSTICA
2	45	4	664 523 060		SCHEIBE		WASHER	RONDELLE	ARANDELA
2	46	1	664 864 052		BOLZEN		PIN	PIVOT	PIVOTE
2	47	1	664 487 997		SPLINT		COTTER PIN	GOUPILLE	PASADOR
2	48	1	664 063 021		NOCKEN		CAM	CAME	LEVA
2	49	2	664 789 100		SCHRAUBE		SCREW	VIS	TORNILLO
2	50	2	664 154 330		MUTTER		NUT	ECROU	TUERCA
2	61	1	664 961 232		LENKRAD		STEERING WHEEL	VOLANT	VOLANTE
2	62	1	664 620 305		STIFT		PIN	GOUPILLE	PASADOR
2	63	1	664 600 114		SCHUTZ		PROTECTION	PROTECTION	PROTECCIÓN
2	71	1	664 600 119		SCHUTZ		PROTECTION	PROTECTION	PROTECCIÓN
2	72	1	664 600 118		SCHUTZ		PROTECTION	PROTECTION	PROTECCIÓN
2	73	2	664 727 810		SCHRAUBE		SCREW	VIS	TORNILLO
2	81	1	664 787 057		HALTER		SUPPORT	SUPPORT	SOPORTE
2	82	1	664 733 002		TANK		TANK	RESERVOIR	DEPÓSITO
2	83	1	664 600 113		SCHUTZ		PROTECTION	PROTECTION	PROTECCIÓN
2	84	1	664 790 000		TANKVERSCHLUSS		CAP	BOUCHON	TAPÓN DEL DEPÓSITO

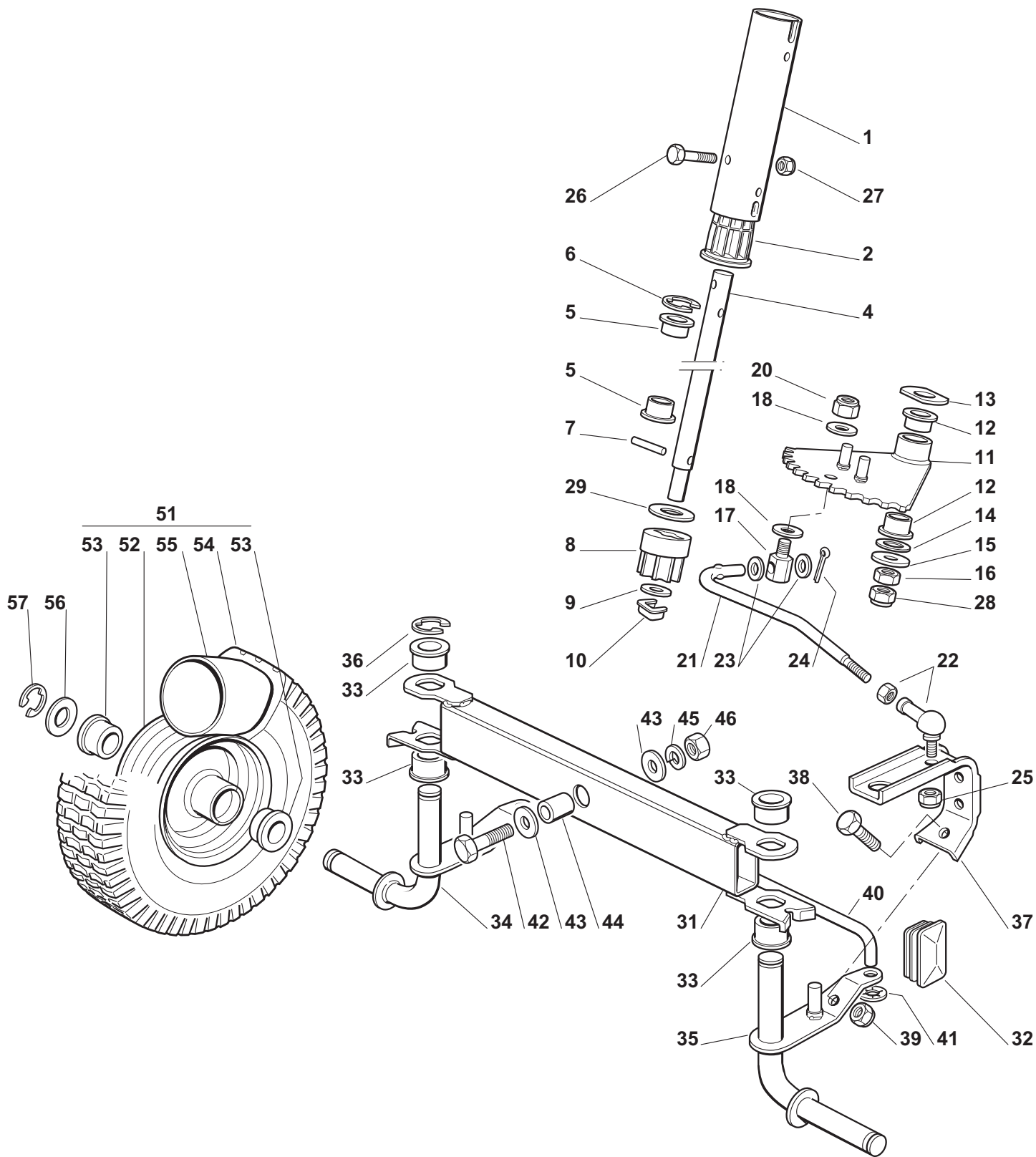

Seite / Page	Pos.	RM-63.7	Teil-Nr. Part No. No. de pièce No. de pieza	Hinweise Notes Renseign. Nota	Bezeichnung	Spezifikation Specification	Description	Désignation	Denominación
3	1	1	664 340 305		VERLÄNGERUNGSSTÜCK		COLUM EXTENSION	TUBE EXTENSION	PIEZA DE PROLONGACIÓN
3	2	1	664 047 005		BUCHSE		BUSH	DOUILLE	CASQUILLO
3	4	1	664 520 052		LENKSÄULE		STEERING COLUMN	COLONNE DE DIRECTION	COLUMNA DE DIRECCIÓN
3	5	2	664 047 004		BUCHSE		BUSH	DOUILLE	CASQUILLO
3	6	1	664 001 010		SPRENGRING		SNAP RING	ANNEAU RESSORT	ANILLO DE SUJECIÓN
3	7	1	664 622 650		STIFT		PIN	GOUILLE	PASADOR
3	8	1	664 570 050		RITZEL		PINION	PIGNON	PIÑÓN
3	9	1	664 521 370		SCHEIBE		WASHER	RONDELLE	ARANDELA
3	10	1	664 436 030		PLÄTTCHEN		PLATE	PLAQUETTE	PLAQUITA
3	11	1	664 735 553		ZAHNKRANZ		RING GEAR	COURONNE	CORONA DENTADA
3	12	2	664 047 004		BUCHSE		BUSH	DOUILLE	CASQUILLO
3	13	1	664 670 054		SCHEIBE		WASHER	RONDELLE	ARANDELA
3	14	1	664 672 152		SCHEIBE		WASHER	RONDELLE	ARANDELA
3	15	1	664 523 070		SCHEIBE		WASHER	RONDELLE	ARANDELA
3	16	1	664 293 200		MUTTER		NUT	ECROU	TUERCA
3	17	1	664 510 056		BOLZEN		PIN	PIVOT	PIVOTE
3	18	2	664 670 008		SCHEIBE		WASHER	RONDELLE	ARANDELA
3	20	1	664 156 602		MUTTER		NUT	ECROU	TUERCA
3	21	1	664 034 066		STANGE		ROD	BARRE	BARRA
3	22	1	664 746 601		GELENK		JOINT	JOINT	ARTICULACIÓN
3	23	2	664 670 008		SCHEIBE		WASHER	RONDELLE	ARANDELA
3	24	1	664 141 418		SPLINT		COTTER PIN	GOUILLE	PASADOR
3	25	1	664 155 000		MUTTER		NUT	ECROU	TUERCA
3	26	2	664 689 515		SCHRAUBE		SCREW	VIS	TORNILLO
3	27	2	664 154 510		MUTTER		NUT	ECROU	TUERCA
3	28	1	664 155 000		MUTTER		NUT	ECROU	TUERCA
3	29	1	664 670 054		SCHEIBE		WASHER	RONDELLE	ARANDELA
3	31	1	664 034 059		KIPPEBEL		EQUALIZER	BALANCIER	PALANCA
3	32	2	664 737 852		VERSCHLUSS		CAP	BOUCHON	TAPÓN
3	33	4	664 047 004		BUCHSE		BUSH	DOUILLE	CASQUILLO
3	34	1	664 230 405		ACHSSCHENKEL RECHTS		STUB AXLE RIGHT	FUSEAU DROITE	MANGUETA DERECHA
3	35	1	664 230 407		ACHSSCHENKEL LINKS		STUB AXLE LEFT	FUSEAU GAUCHE	MANGUETA IZQUIERDA
3	36	1	664 000 970		SPRENGRING		SNAP RING	ANNEAU RESSORT	ANILLO DE SUJECIÓN
3	37	1	664 778 041		HALTER		SUPPORT	SUPPORT	SOPORTE
3	38	1	664 793 102		SCHRAUBE		SCREW	VIS	TORNILLO
3	39	1	664 155 000		MUTTER		NUT	ECROU	TUERCA
3	40	1	664 840 051		SPANNSTANGE		TIE ROD	TIRANT	SENSOR
3	41	2	664 604 899		SICHERUNGSSCHEIBE		SAFETY WASHER	RONDELLE DE SÉCURITÉ	ARANDELA SEGURIDAD
3	42	1	664 692 695		SCHRAUBE		SCREW	VIS	TORNILLO
3	43	2	664 523 100		SCHEIBE		WASHER	RONDELLE	ARANDELA
3	44	1	664 160 016		DISTANZRING		SPACER	ENTRETOISE	DISTANCIADOR
3	45	1	664 587 100		FEDERRING		GROWER	GROWER	ARANDELA ELÁSTICA
3	46	1	664 295 300		MUTTER		NUT	ECROU	TUERCA
3	51	2	664 680 056		VORDERRAD		FRONT WHEEL	ROUE AVANT	RUEDA
3	52	1	664 044 002		FELGE		RIMM	JANTE	LLANTA
3	53	4	664 045 070		BUCHSE		BUSH	DOUILLE	CASQUILLO
3	54	1	664 590 058		REIFEN		SHOE	PNEU	NEUMÁTICO
3	55	1	664 590 056		REIFENSCHLAUCH		INNER TUBE	CHAMBRE A AIRE	CÁMARA
3	56	2	664 521 390		SCHEIBE		WASHER	RONDELLE	ARANDELA
3	57	2	664 000 970		SPRENGRING		SNAP RING	ANNEAU RESSORT	ANILLO DE SUJECIÓN

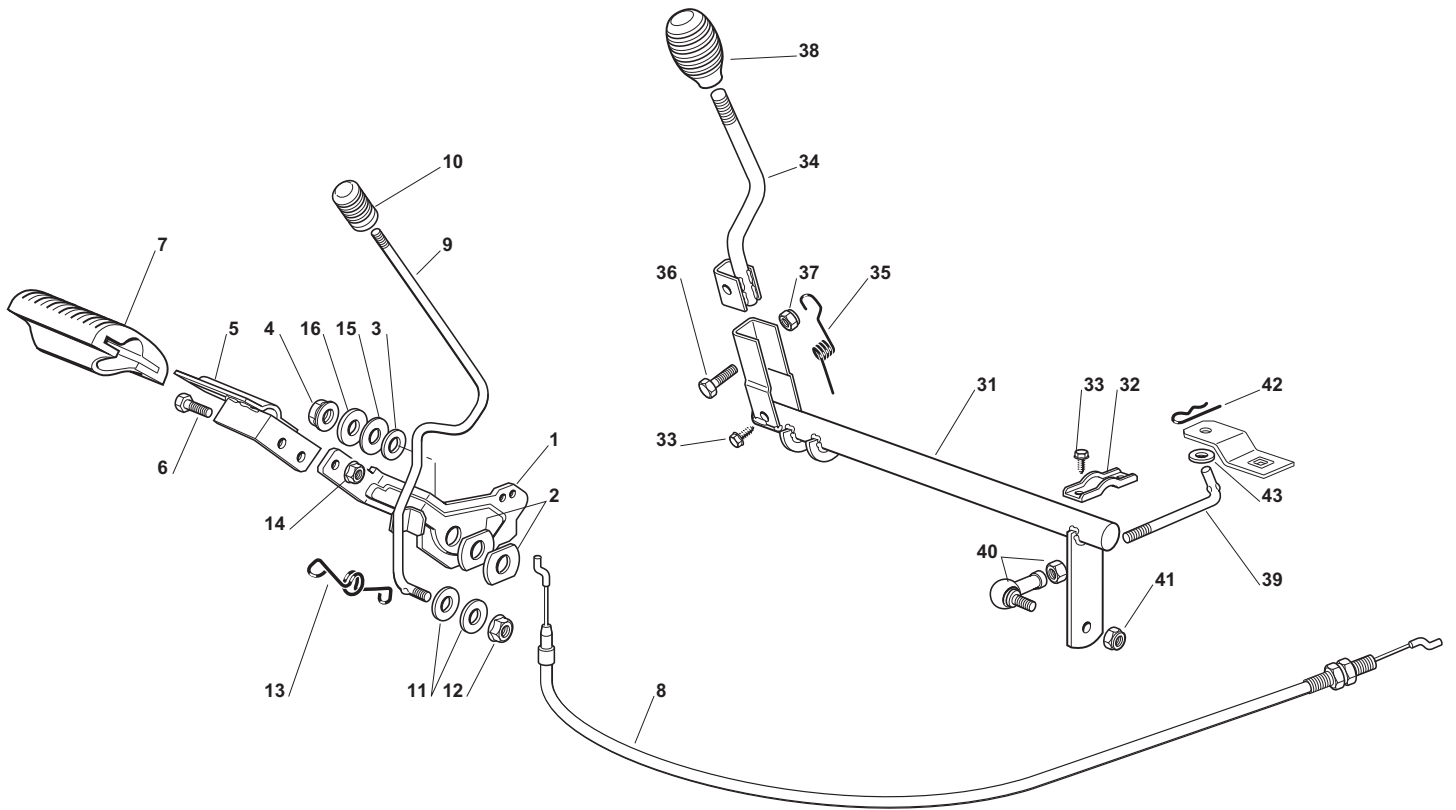

(2009) RM-63.7

4

GETRIEBE UND BREMSE ANTRIEB
 DRIVE AND BRAKE CONTROLS
 COMMANDE TRANSMISSION ET FREIN
 ACCIONAMIENTO TRANSMISIÓN Y FRENOS

DOLMAR

 A member of the *Makita* Group

Seite / Page	Pos.	Teil-Nr. Part No. No. de pièce No. de pieza	Hinweise Notes Renseign. Nota	Bezeichnung	Spezifikation Specification	Description	Désignation	Denominación
4	1	1 664 500 051		PEDAL		PEDAL	PEDAL	PEDAL
4	2	2 664 670 054		SCHEIBE		WASHER	RONDELLE	ARANDELA
4	3	1 664 521 350		SCHEIBE		WASHER	RONDELLE	ARANDELA
4	4	1 664 154 210		MUTTER		NUT	ECROU	TUERCA
4	5	1 664 503 005		PEDAL OBEN		PEDAL	PEDAL	PEDAL
4	6	2 664 791 201		SCHRAUBE		SCREW	VIS	TORNILLO
4	7	1 664 110 269		PEDALGUMMI		PEDAL PAD	COUVRE ETRIER	GOMA DEL PEDAL
4	8	1 664 207 105		BOWDENZUG		BOWDEN CABLE	CÂBLE BOWDEN	CABLE BOWDEN
4	9	1 664 034 064		STANGE		ROD	BARRE	BARRA
4	10	1 664 395 050		KNOPF		KNOB	POIGNEE	BOTÓN
4	11	2 664 670 011		SCHEIBE		WASHER	RONDELLE	ARANDELA
4	12	1 664 154 210		MUTTER		NUT	ECROU	TUERCA
4	13	1 664 430 564		FEDER		SPRING	RESSORT	MUELLE
4	14	2 664 292 102		MUTTER		NUT	ECROU	TUERCA
4	15	1 664 670 055		SCHEIBE		WASHER	RONDELLE	ARANDELA
4	16	1 664 523 060		SCHEIBE		WASHER	RONDELLE	ARANDELA
4	31	1 664 001 021		ACHSE		AXLE	AXE	EJE
4	32	2 664 546 015		PLATTE		PLATE	PLAQUE	PLACA
4	33	5 664 729 600		SCHRAUBE		SCREW	VIS	TORNILLO
4	34	1 664 317 071		HEBEL		LEVER	LEVIER	PALANCA
4	35	1 664 430 570		FEDER		SPRING	RESSORT	MUELLE
4	36	1 664 674 700		SCHRAUBE		SCREW	VIS	TORNILLO
4	37	1 664 154 510		MUTTER		NUT	ECROU	TUERCA
4	38	1 664 394 510		GRIFF		KNOB	POIGNEE	MANETA
4	39	1 664 034 063		STANGE		ROD	BARRE	BARRA
4	40	1 664 746 601		GELENK		JOINT	JOINT	ARTICULACIÓN
4	41	1 664 155 000		MUTTER		NUT	ECROU	TUERCA
4	42	1 664 487 997		SPLINT		COTTER PIN	GOUPILLE	PASADOR
4	43	1 664 670 011		SCHEIBE		WASHER	RONDELLE	ARANDELA

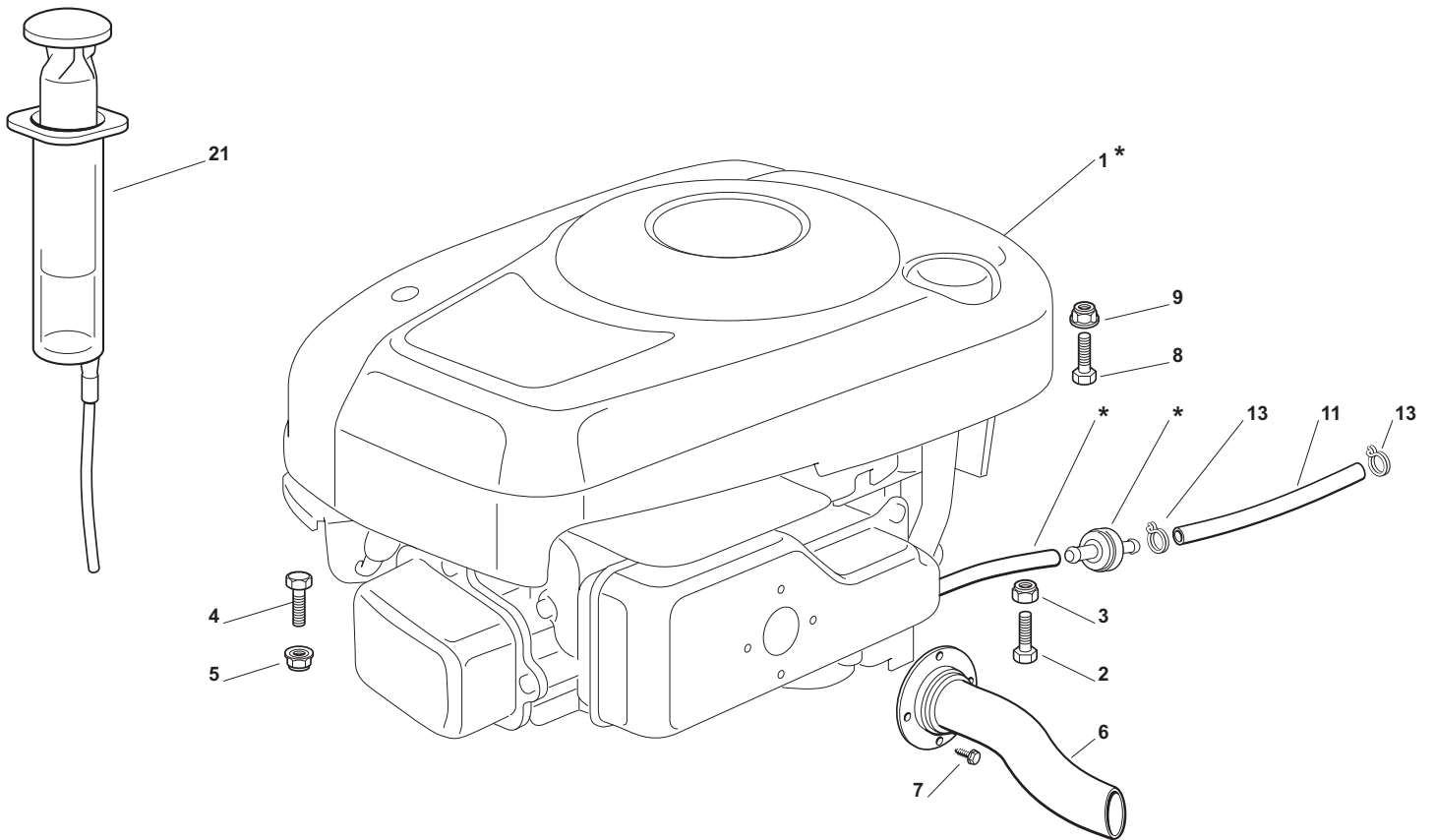

Seite / Page	Pos.	RM-63.7	Teil-Nr. Part No. No. de pièce No. de pieza	Hinweise Notes Renseign. Nota	Bezeichnung	Spezifikation Specification	Description	Désignation	Denominación
5	*	x			ZUM AUSTAUSCH DER MIT «*» GEKENNZEICHNETEN TEILE, WENDEN SIE SICH AN DEN KUNDENDIENST DES MOTORHERSTELLERS .		TO REPLACE THE PARTS MARKED «*» SEEK ASSISTANCE FROM THE ENGINE MANUFACTURER'S AFTER SALES SERVICE.	POUR LE REPLACEMENT DES PIÈCES MARQUÉES AVEC «*» S'ADRESSER AU SERVICE APRÈS VENTES DU CONSTRUCTEUR DU MOTEUR.	PARA RECAMBIO DE LAS PIEZAS MARCADO CON «*» FAVOR SE DIRIGEN AL SERVICIO TÉCNICO DEL FABRICANTE DEL MOTOR.
5	1	1			TECUMSEH MOTOR		TECUMSEH ENGINE	TECUMSEH MOTEUR	TECUMSEH MOTOR
5	2	1	664 691 800		SCHRAUBE		SCREW	VIS	TORNILLO
5	3	1	664 155 000		MUTTER		NUT	ECROU	TUERCA
5	4	1	664 793 701		SCHRAUBE	M8X30	SCREW	VIS	TORNILLO
5	5	1	664 154 210		MUTTER		NUT	ECROU	TUERCA
5	6	1	664 999 053		ABGASROHR		TUBE	TUBE	TUBO
5	7	4	664 735 111		SCHRAUBE		SCREW	VIS	TORNILLO
5	8	1	664 691 100		SCHRAUBE		SCREW	VIS	TORNILLO
5	9	1	664 154 210		MUTTER		NUT	ECROU	TUERCA
5	11	1	664 869 035		SCHLAUCH		TUBE	TUBE	TUBO
5	13	2	664 375 051		KABELBEFESTIGUNG		FAIRLEAD	FIXATION CABLE	SUJETACABLE
5	21	1	664 718 000		SPRITZE		SYRINGE	SIRINGUE	JERINGUILLA

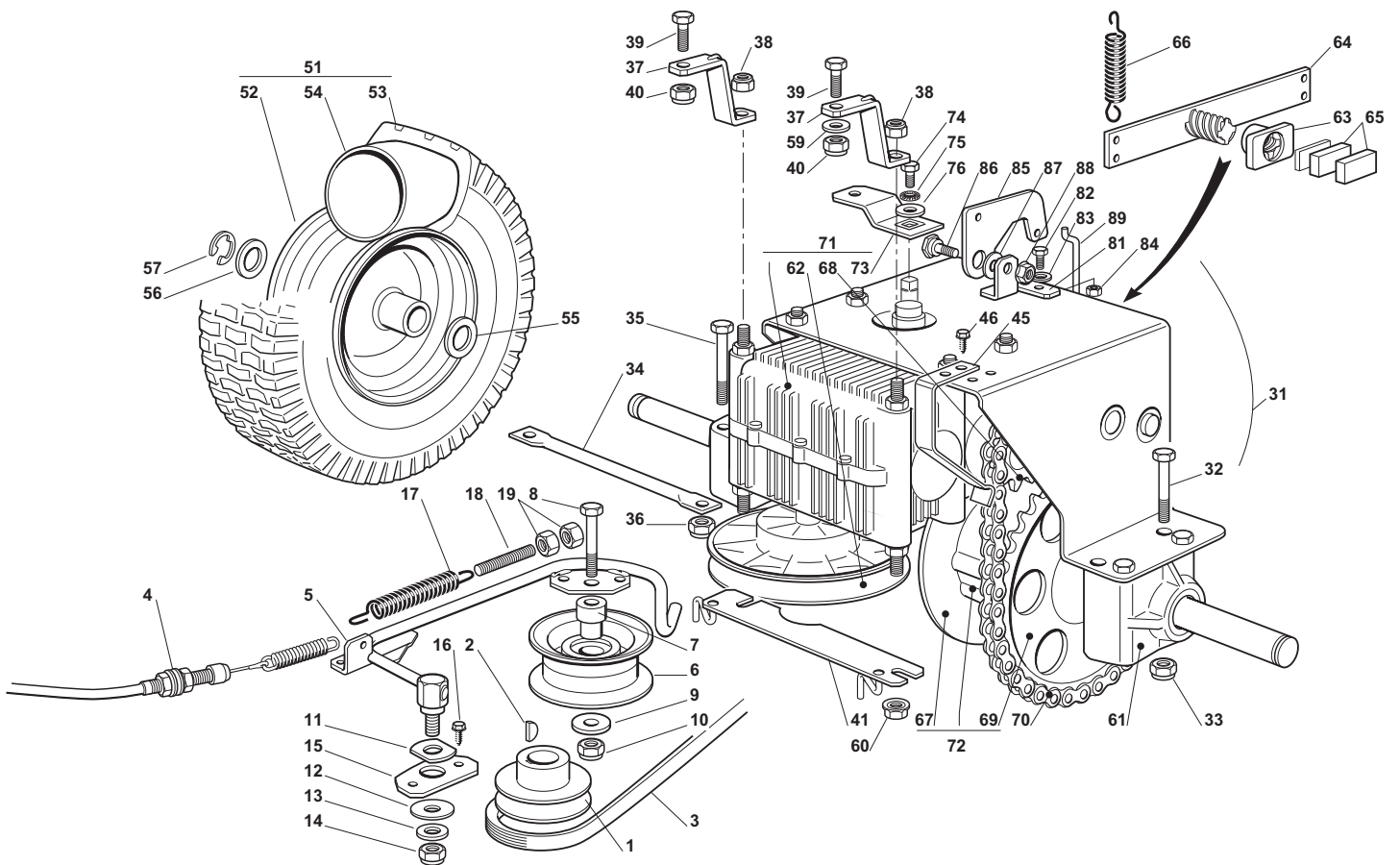

Seite / Page	Pos.	Teil-Nr. Part No. No. de pièce No. de pieza	Hinweise Notes Renseign. Nota	Bezeichnung	Spezifikation Specification	Description	Désignation	Denominación
6	1	1 664 604 006		RIEMENSCHLEIBE		PULLEY	POULIE	POLEA
6	2	1 664 139 100		KEIL		KEY	CLAVETTE	CHAVETA
6	3	1 664 061 406		RIEMEN		BELT	COURROIE	CORREA
6	4	1 664 207 103		BOWDENZUG		BOWDEN CABLE	CÂBLE BOWDEN	CABLE BOWDEN
6	5	1 664 317 077		HEBEL		LEVER	LEVIER	PALANCA
6	6	1 664 604 007		RIEMENSCHLEIBE		PULLEY	POULIE	POLEA
6	7	1 664 047 007		BUCHSE		BUSH	DOUILLE	CASQUILLO
6	8	1 664 691 200		SCHRAUBE		SCREW	VIS	TORNILLO
6	9	1 664 523 060		SCHLEIBE		WASHER	RONDELLE	ARANDELA
6	10	1 664 155 000		MUTTER		NUT	ECROU	TUERCA
6	11	1 664 670 054		SCHLEIBE		WASHER	RONDELLE	ARANDELA
6	12	1 664 523 070		SCHLEIBE		WASHER	RONDELLE	ARANDELA
6	13	1 664 670 011		SCHLEIBE		WASHER	RONDELLE	ARANDELA
6	14	1 664 155 000		MUTTER		NUT	ECROU	TUERCA
6	15	1 664 546 029		PLATTE		PLATE	PLAQUE	PLACA
6	16	2 664 735 121		SCHRAUBE		SCREW	VIS	TORNILLO
6	17	1 664 430 219		FEDER		SPRING	RESSORT	MUELLE
6	18	1 664 840 005		SPANNSTANGE		TIE ROD	TIRANT	SENSOR
6	19	2 664 293 200		MUTTER		NUT	ECROU	TUERCA
6	31	1 664 400 970		ANTRIEB KPL.		TRANSMISSION UNIT	GROUPE TRANSMISSION	UNIDAD DE TRACCIÓN
6	32	3 664 692 050		SCHRAUBE		SCREW	VIS	TORNILLO
6	33	4 664 154 210		MUTTER		NUT	ECROU	TUERCA
6	34	1 664 840 053		VERSTÄRKUNG		STIFFENING	REINFORCEMENT	REFUERZO INFERIOR
6	35	1 664 943 001		SCHRAUBE		SCREW	VIS	TORNILLO
6	36	2 664 155 000		MUTTER		NUT	ECROU	TUERCA
6	37	2 664 999 119		VERSTÄRKUNG		STIFFENING	REINFORCEMENT	REFUERZO INFERIOR
6	38	2 664 155 000		MUTTER		NUT	ECROU	TUERCA
6	39	1 664 793 701		SCHRAUBE	M8X30	SCREW	VIS	TORNILLO
6	40	1 664 293 201		MUTTER		NUT	ECROU	TUERCA
6	41	1 664 250 051		RIEMENFÜHRUNG		BELT GUIDE	GUIDE DE COURROIRE	GUÍA DE LA CORREA
6	45	1 664 394 830		FEDER		SPRING	RESSORT	MUELLE
6	46	2 664 735 104		SCHRAUBE		SCREW	VIS	TORNILLO
6	51	2 664 680 057		HINTERRAD		WHEEL	ROUE	RUEDA
6	52	2 664 044 005		FELGE		RIMM	JANTE	LLANTA
6	53	2 664 590 059		REIFEN		SHOE	PNEU	NEUMÁTICO
6	54	2 664 590 057		REIFENSCHLAUCH		INNER TUBE	CHAMBRE A AIRE	CÁMARA
6	55	2 664 521 410		SCHLEIBE		WASHER	RONDELLE	ARANDELA
6	56	2 664 670 005		SCHLEIBE		WASHER	RONDELLE	ARANDELA
6	57	2 664 001 010		SPRENGRING		SNAP RING	ANNEAU RESSORT	ANILLO DE SUJECIÓN
6	59	1 664 523 070		SCHLEIBE		WASHER	RONDELLE	ARANDELA
6	60	2 664 293 201		MUTTER		NUT	ECROU	TUERCA
6	61	3 664 700 056		BUCHSE		BUSH	DOUILLE	CASQUILLO
6	62	1 664 700 050		RIEMENSCHLEIBE		PULLEY	POULIE	POLEA
6	63	1 664 700 051		MUTTER		NUT	ECROU	TUERCA
6	64	1 664 700 053		HEBEL		LEVER	LEVIER	PALANCA
6	65	2 664 700 052		BREMSBELÄGE		PAD	PLAQUETTE	GUARNICIÓN DEL FRENO
6	66	1 664 700 048		FEDER		SPRING	RESSORT	MUELLE
6	67	1 664 700 054		BREMSSCHLEIBE		BRAKE DISC	DISQUE Á FREIN	DISCO DE FRENO
6	68	1 664 700 049		RITZEL		PINION	PIGNON	PIÑÓN
6	69	1 664 700 055		ZAHNKETTENRAD		SPROCKET	COURONNE	RUEDA DENTADA
6	70	1 664 700 047		KETTE		CHAIN	CHAÎNE	CADENA
6	71	1 664 400 972		GETRIEBE		GEAR BOX	BÔTE DE VITESSE	ENGRANAJE
6	72	1 664 400 971		DIFFERENTIAL		DIFFERENTIAL	DIFFERENTIEL	DIFERENCIAL
6	73	1 664 315 105		HEBEL		LEVER	LEVIER	PALANCA
6	74	1 664 791 011		SCHRAUBE		SCREW	VIS	TORNILLO
6	75	1 664 540 040		SCHLEIBE		WASHER	RONDELLE	ARANDELA
6	76	1 664 680 009		SCHLEIBE		WASHER	RONDELLE	ARANDELA
6	81	1 664 753 079		WINKEL		BRACKET	SUPPORT	SOPORTE
6	82	2 664 791 201		SCHRAUBE		SCREW	VIS	TORNILLO
6	83	2 664 523 040		SCHLEIBE		WASHER	RONDELLE	ARANDELA
6	84	2 664 292 102		MUTTER		NUT	ECROU	TUERCA
6	85	1 664 772 145		HALTER		CLAMP	ETRIER	SOPORTE

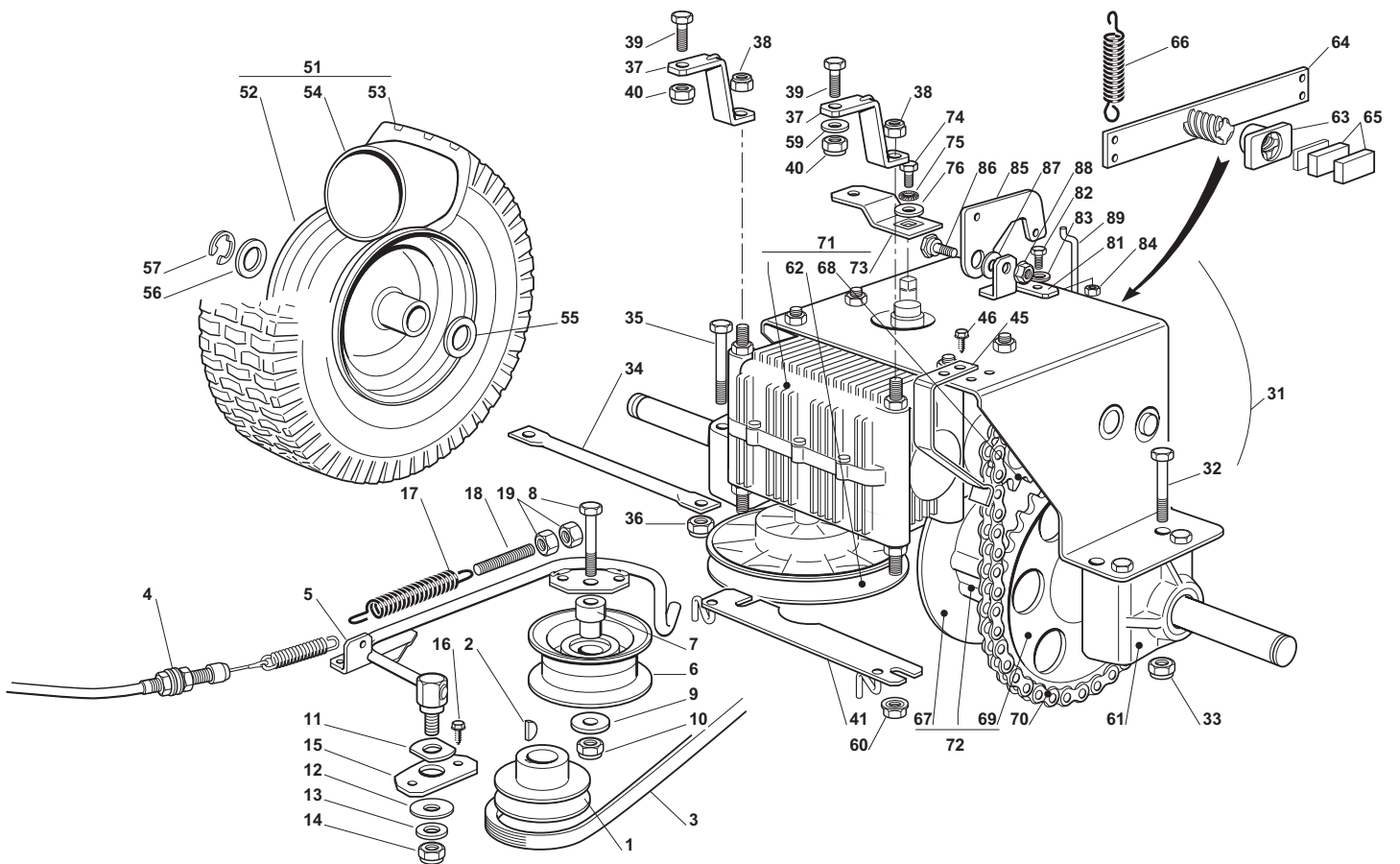

(2009) RM-63.7

6

Getriebe
Gear
Engrenage
Engranaje

DOLMAR

A member of the *Takita* Group

Seite / Page	Pos.	RM-63.7	Teil-Nr. Part No. No. de pièce No. de pieza	Hinweise Notes Renseign. Nota	Bezeichnung	Spezifikation Specification	Description	Désignation	Denominación
6	86	1	664 524 970		BOLZEN		PIN	PIVOT	PIVOTE
6	87	1	664 670 011		SCHEIBE		WASHER	RONDELLE	ARANDELA
6	88	1	664 154 210		MUTTER		NUT	ECROU	TUERCA
6	89	1	664 034 076		STANGE		ROD	BARRE	BARRA

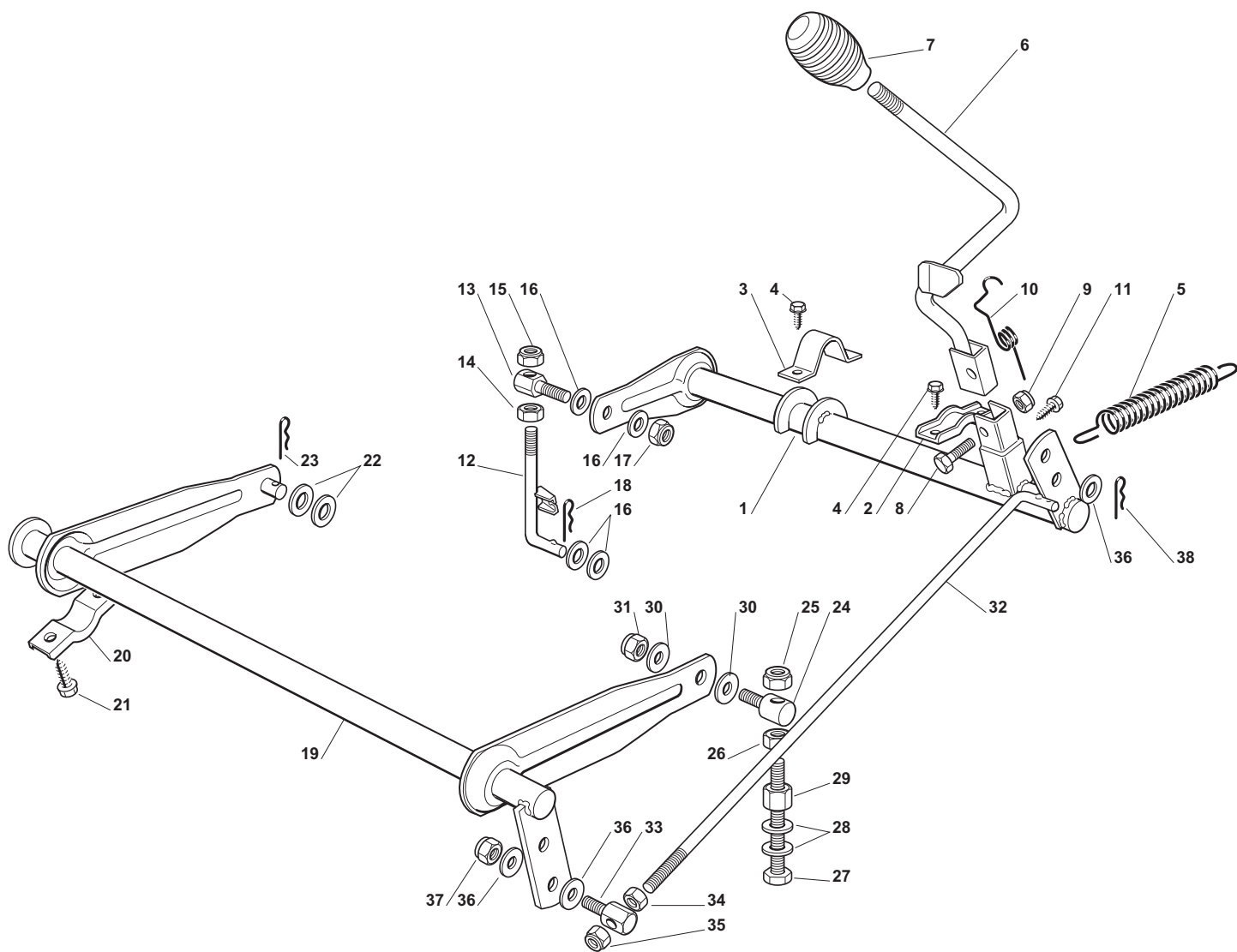

Seite / Page	Pos.	Teil-Nr. Part No. No. de pièce No. de pieza	Hinweise Notes Renseign. Nota	Bezeichnung	Spezifikation Specification	Description	Désignation	Denominación
7	1	1 664 001 017		ACHSE		AXLE	AXE	EJE
7	2	1 664 546 015		PLATTE		PLATE	PLAQUE	PLACA
7	3	1 664 547 037		PLATTE		PLATE	PLAQUE	PLACA
7	4	4 664 729 600		SCHRAUBE		SCREW	VIS	TORNILLO
7	5	1 664 430 568		FEDER		SPRING	RESSORT	MUELLE
7	6	1 664 317 075		HEBEL		LEVER	LEVIER	PALANCA
7	7	1 664 394 510		GRIFF		KNOB	POIGNEE	MANETA
7	8	1 664 674 700		SCHRAUBE		SCREW	VIS	TORNILLO
7	9	1 664 154 510		MUTTER		NUT	ECROU	TUERCA
7	10	1 664 430 574		FEDER		SPRING	RESSORT	MUELLE
7	11	1 664 729 600		SCHRAUBE		SCREW	VIS	TORNILLO
7	12	1 664 002 073		STANGE		ROD	BARRE	BARRA
7	13	1 664 510 056		BOLZEN		PIN	PIVOT	PIVOTE
7	14	1 664 295 200		MUTTER		NUT	ECROU	TUERCA
7	15	1 664 156 602		MUTTER		NUT	ECROU	TUERCA
7	16	4 664 670 008		SCHEIBE		WASHER	RONDELLE	ARANDELA
7	17	1 664 156 602		MUTTER		NUT	ECROU	TUERCA
7	18	1 664 487 997		SPLINT		COTTER PIN	GOUPILLE	PASADOR
7	19	1 664 001 019		ACHSE		AXLE	AXE	EJE
7	20	2 664 546 015		PLATTE		PLATE	PLAQUE	PLACA
7	21	4 664 731 350		SCHRAUBE		SCREW	VIS	TORNILLO
7	22	2 664 670 008		SCHEIBE		WASHER	RONDELLE	ARANDELA
7	23	1 664 487 997		SPLINT		COTTER PIN	GOUPILLE	PASADOR
7	24	1 664 510 007		BOLZEN		PIN	PIVOT	PIVOTE
7	25	1 664 156 602		MUTTER		NUT	ECROU	TUERCA
7	26	1 664 295 200		MUTTER		NUT	ECROU	TUERCA
7	27	1 664 794 970		SCHRAUBE		SCREW	VIS	TORNILLO
7	28	2 664 521 360		SCHEIBE		WASHER	RONDELLE	ARANDELA
7	29	1 664 154 250		MUTTER		NUT	ECROU	TUERCA
7	30	2 664 670 008		SCHEIBE		WASHER	RONDELLE	ARANDELA
7	31	1 664 156 602		MUTTER		NUT	ECROU	TUERCA
7	32	1 664 034 065		STANGE		ROD	BARRE	BARRA
7	33	1 664 510 040		BOLZEN		PIN	PIVOT	PIVOTE
7	34	1 664 293 200		MUTTER		NUT	ECROU	TUERCA
7	35	1 664 155 000		MUTTER		NUT	ECROU	TUERCA
7	36	3 664 670 011		SCHEIBE		WASHER	RONDELLE	ARANDELA
7	37	1 664 155 000		MUTTER		NUT	ECROU	TUERCA
7	38	1 664 487 997		SPLINT		COTTER PIN	GOUPILLE	PASADOR

(2009) RM-63.7

8

SCHNEIDWERKZEUG (1)
CUTTING PLATE (1)
PLATEAU DE COUPE (1)
HERRAMIENTA DE CORTE (1)

DOLMAR
A member of the *Takita* Group

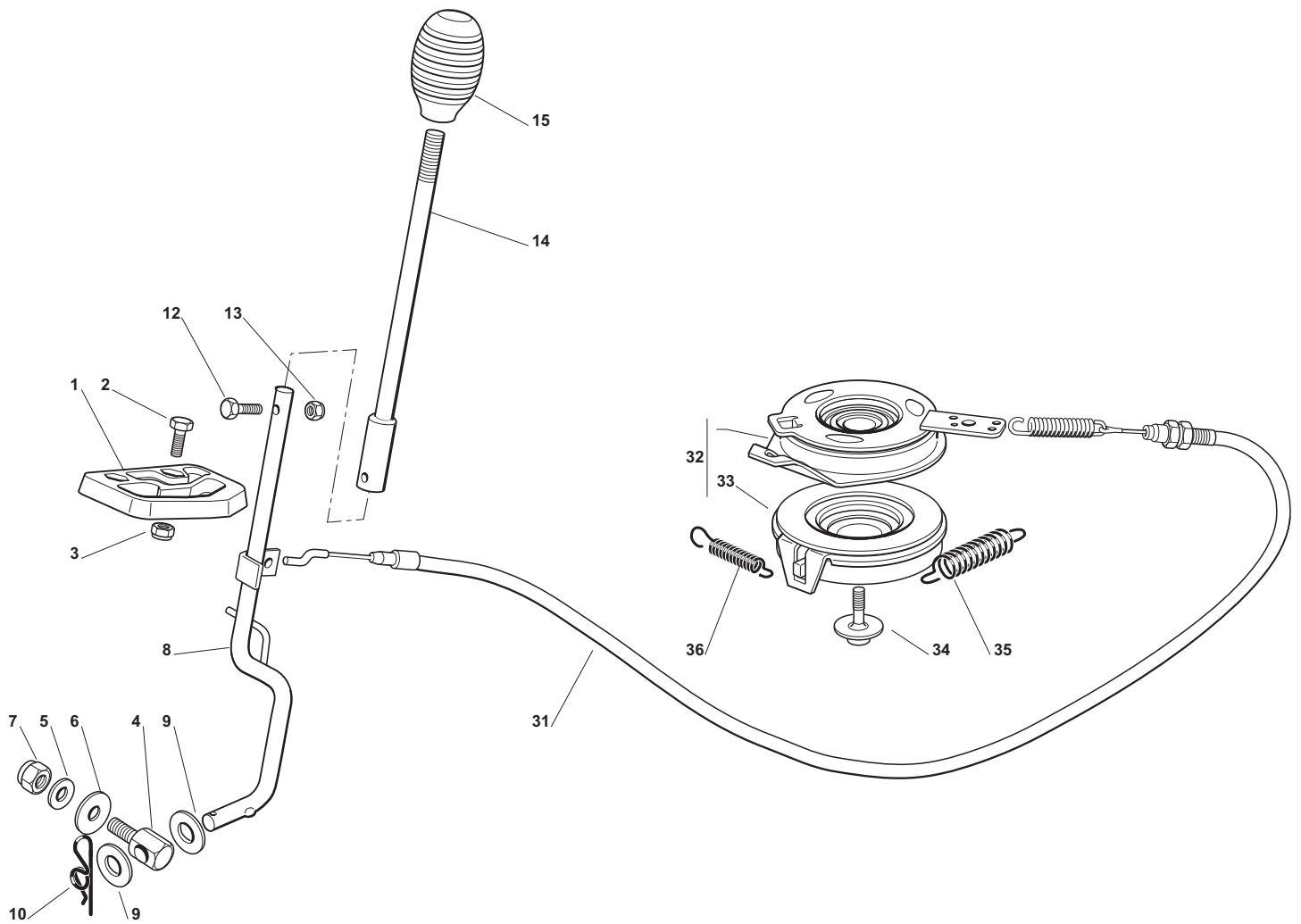

(2009) RM-63.7

8

SCHNEIDWERKZEUG (1)
 CUTTING PLATE (1)
 PLATEAU DE COUPE (1)
 HERRAMIENTA DE CORTE (1)

DOLMAR

 A member of the *Makita* Group

Seite / Page	Pos.	RM-63.7	Teil-Nr. Part No. No. de pièce No. de pieza	Hinweise Notes Renseign. Nota	Bezeichnung	Spezifikation Specification	Description	Désignation	Denominación
8	1	1	664 487 001		GLEITBLOCK		SHOE	BLOC DE GLISSEMENT	BLOQUE DESLIZANTE
8	2	2	664 791 201		SCHRAUBE		SCREW	VIS	TORNILLO
8	3	2	664 154 510		MUTTER		NUT	ECROU	TUERCA
8	4	1	664 510 107		BOLZEN		PIN	PIVOT	PIVOTE
8	5	1	664 670 011		SCHEIBE		WASHER	RONDELLE	ARANDELA
8	6	1	664 672 152		SCHEIBE		WASHER	RONDELLE	ARANDELA
8	7	1	664 155 000		MUTTER		NUT	ECROU	TUERCA
8	8	1	664 317 073		HEBEL		LEVER	LEVIER	PALANCA
8	9	2	664 660 100		SCHEIBE		WASHER	RONDELLE	ARANDELA
8	10	1	664 487 997		SPLINT		COTTER PIN	GOUPILLE	PASADOR
8	12	1	664 789 020		SCHRAUBE		SCREW	VIS	TORNILLO
8	13	1	664 154 330		MUTTER		NUT	ECROU	TUERCA
8	14	1	664 317 079		HEBEL		LEVER	LEVIER	PALANCA
8	15	1	664 394 510		GRIFF		KNOB	POIGNEE	MANETA
8	31	1	664 207 104		BOWDENZUG		BOWDEN CABLE	CÂBLE BOWDEN	CABLE BOWDEN
8	32	1	664 399 065		KUPPLUNG MECHANISCH		CLUTCH	EMBAYAGE	EMBRAGUE
8	33	1	664 399 066		KUPPLUNG MECHANISCH		CLUTCH	EMBAYAGE	EMBRAGUE
8	34	1	664 735 460		SCHRAUBE		SCREW	VIS	TORNILLO
8	35	1	664 430 579		FEDER		SPRING	RESSORT	MUELLE
8	36	1	664 450 110		FEDER		SPRING	RESSORT	MUELLE

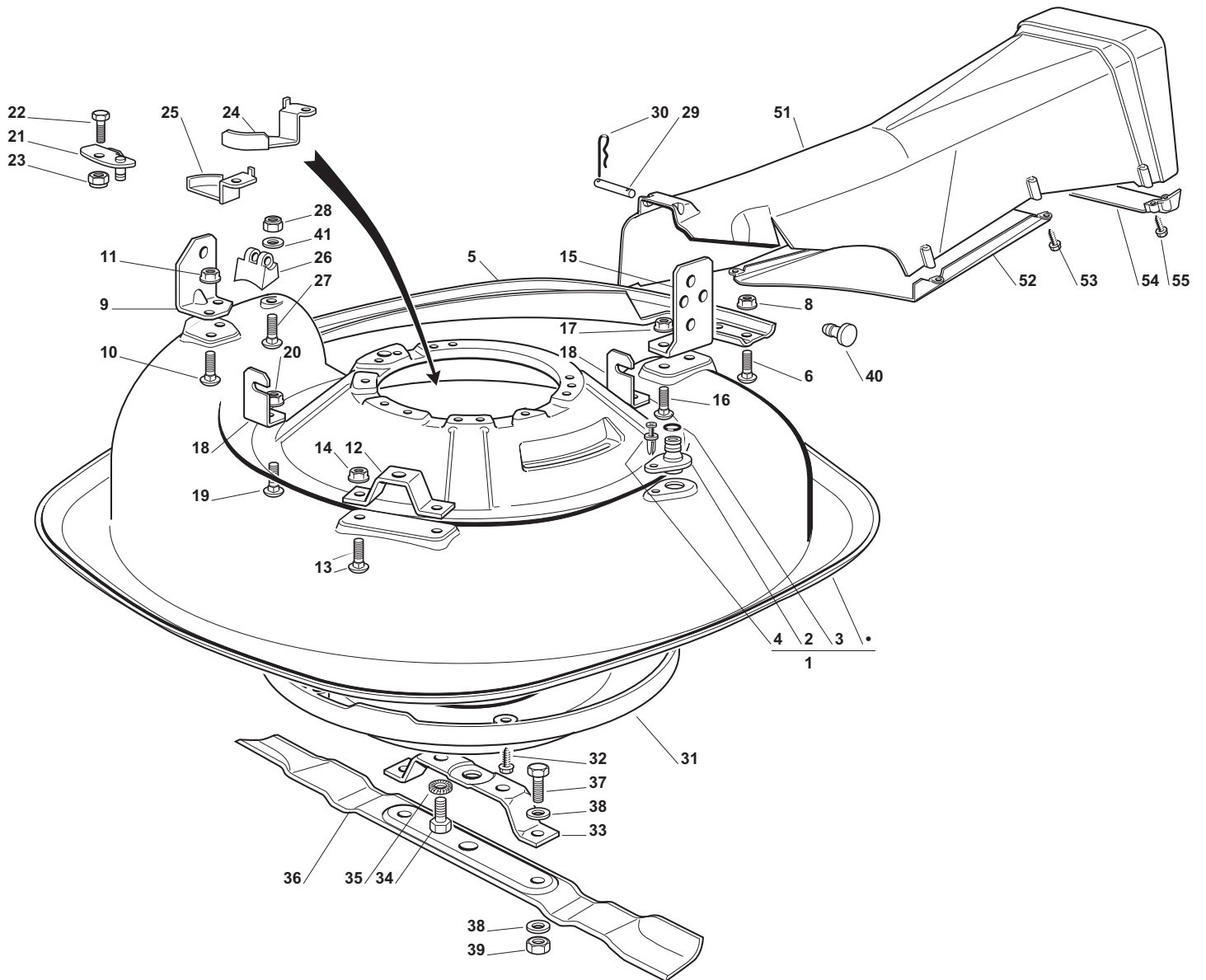

(2009) RM-63.7

9

SCHNEIDWERKZEUG (2)
CUTTING PLATE (2)
PLATEAU DE COUPE (2)
HERRAMIENTA DE CORTE (2)

DOLMAR
A member of the *Makita* Group

Seite / Page	Pos.	RM-63.7	Teil-Nr. Part No. No. de pièce No. de pieza	Hinweise Notes Renseign. Nota	Bezeichnung	Spezifikation Specification	Description	Désignation	Denominación
9	1	1	664 564 095		SCHNEIDWERKZEUG		CUTTING PLATE	PLATEAU DE COUPE	HERRAMIENTA DE CORTE
9	2	1	664 033 060		WASSERANSCHLUSS		WATER HOSE CONNECTION	RACCORD TUYAU D'EAU	TOMA DE AGUA
9	3	1	664 035 000		O-RING		O-RING	O-RING	JUNTA TÓRICA
9	4	1	664 500 030		NIET		RIVET	RIVET	REMACHE
9	5	1	664 650 103		VERSTÄRKUNG		STIFFENING	REINFORCEMENT	REFUERZO INFERIOR
9	6	4	664 815 200		SCHRAUBE		SCREW	VIS	TORNILLO
9	8	4	664 292 102		MUTTER		NUT	ECROU	TUERCA
9	9	1	664 772 119		HALTER		CLAMP	ETRIER	SOPORTE
9	10	2	664 818 690		SCHRAUBE		SCREW	VIS	TORNILLO
9	11	2	664 293 201		MUTTER		NUT	ECROU	TUERCA
9	12	1	664 772 133		HALTER		CLAMP	ETRIER	SOPORTE
9	13	2	664 818 690		SCHRAUBE		SCREW	VIS	TORNILLO
9	14	2	664 293 201		MUTTER		NUT	ECROU	TUERCA
9	15	1	664 721 272		HALTER		CLAMP	ETRIER	SOPORTE
9	16	2	664 818 690		SCHRAUBE		SCREW	VIS	TORNILLO
9	17	2	664 293 201		MUTTER		NUT	ECROU	TUERCA
9	18	2	664 753 071		WINKEL		BRACKET	SUPPORT	SOPORTE
9	19	2	664 818 690		SCHRAUBE		SCREW	VIS	TORNILLO
9	20	2	664 293 201		MUTTER		NUT	ECROU	TUERCA
9	21	1	664 545 063		PLATTE		PLATE	PLAQUE	PLACA
9	22	1	664 792 611		SCHRAUBE		SCREW	VIS	TORNILLO
9	23	1	664 155 000		MUTTER		NUT	ECROU	TUERCA
9	24	1	664 546 041		PLATTE		PLATE	PLAQUE	PLACA
9	25	1	664 546 043		PLATTE		PLATE	PLAQUE	PLACA
9	26	1	664 230 200		HAKEN		HOOK	CROCHET	GANCHO
9	27	1	664 815 210		SCHRAUBE		SCREW	VIS	TORNILLO
9	28	1	664 154 510		MUTTER		NUT	ECROU	TUERCA
9	29	1	664 510 097		BOLZEN		PIN	PIVOT	PIVOTE
9	30	2	664 487 997		SPLINT		COTTER PIN	GOUPILLE	PASADOR
9	31	1	664 600 122		SCHUTZ		PROTECTION	PROTECTION	PROTECCIÓN
9	32	5	664 728 530		SCHRAUBE		SCREW	VIS	TORNILLO
9	33	1	664 787 045		HALTER		SUPPORT	SUPPORT	SOPORTE
9	34	2	664 794 110		SCHRAUBE		SCREW	VIS	TORNILLO
9	35	2	664 540 070		SCHEIBE		WASHER	RONDELLE	ARANDELA
9	36	1	664 109 504		MESSER		BLADE	LAME	CUCHILLA ESTÁNDAR
9	37	2	664 793 102		SCHRAUBE		SCREW	VIS	TORNILLO
9	38	4	664 523 060		SCHEIBE		WASHER	RONDELLE	ARANDELA
9	39	2	664 155 010		MUTTER		NUT	ECROU	TUERCA
9	40	1	664 275 000		GUMMI		GROMMET	CAOUTCHOUC	CAUCHO
9	41	1	664 521 330		SCHEIBE		WASHER	RONDELLE	ARANDELA
9	51	1	664 107 502		BLECHSATZ		CONVEYOR	CONVOYEUR	JUEGO DE CHAPA
9	52	1	664 140 056		ABWEISER		DEFLECTOR	DEFLECTEUR	DEFLECTOR
9	53	5	664 735 402		SCHRAUBE		SCREW	VIS	TORNILLO
9	54	1	664 650 120		VERSTÄRKUNG		STIFFENING	REINFORCEMENT	REFUERZO INFERIOR
9	55	2	664 735 410		SCHRAUBE		SCREW	VIS	TORNILLO

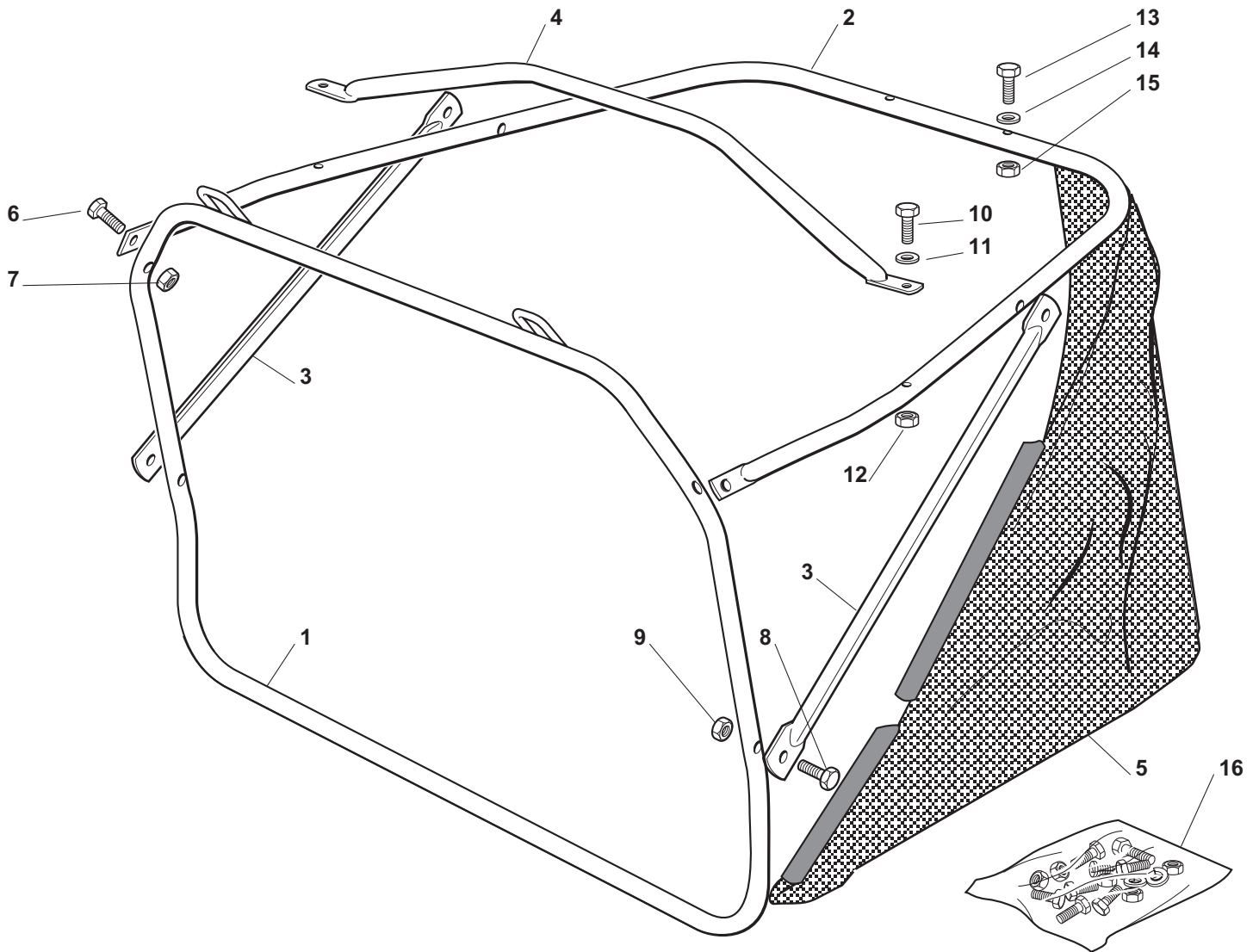

Seite / Page	Pos.	Teil-Nr. Part No. No. de pièce No. de pieza	Hinweise Notes Renseign. Nota	Bezeichnung	Spezifikation Specification	Description	Désignation	Denominación
10	1	664 801 121		VORDERRAHMEN		FRONT FRAME	CHASSIS ANTÉRIEUR	CHASIS
10	2	664 801 119		OBERERRAHMEN		UPPER FRAME	CHASSIS SUPERIEUR	CHASIS SUPERIOR
10	3	664 650 117		VERSTÄRKUNG		STIFFENING	REINFORCEMENT	REFUERZO INFERIOR
10	4	664 394 051		GRIFF		HANDLE	POIGNEE	MANETA
10	5	664 106 068		GRASS-SACK		GRASS CATCHER	BAC	CESTO
10	6	664 789 020		SCHRAUBE		SCREW	VIS	TORNILLO
10	7	664 154 330		MUTTER		NUT	ECROU	TUERCA
10	8	664 789 020		SCHRAUBE		SCREW	VIS	TORNILLO
10	9	664 154 330		MUTTER		NUT	ECROU	TUERCA
10	10	664 789 210		SCHRAUBE		SCREW	VIS	TORNILLO
10	11	664 521 331		SCHEIBE		WASHER	RONDELLE	ARANDELA
10	12	664 154 330		MUTTER		NUT	ECROU	TUERCA
10	13	664 674 530		SCHRAUBE		SCREW	VIS	TORNILLO
10	14	664 521 331		SCHEIBE		WASHER	RONDELLE	ARANDELA
10	15	664 154 330		MUTTER		NUT	ECROU	TUERCA
10	16	664 180 186		SCHRAUBENAUSRÜSTUNG		SCREWS OUTFIT	ENSEMBLE DES VIS	JUEGO DE TORNILLOS

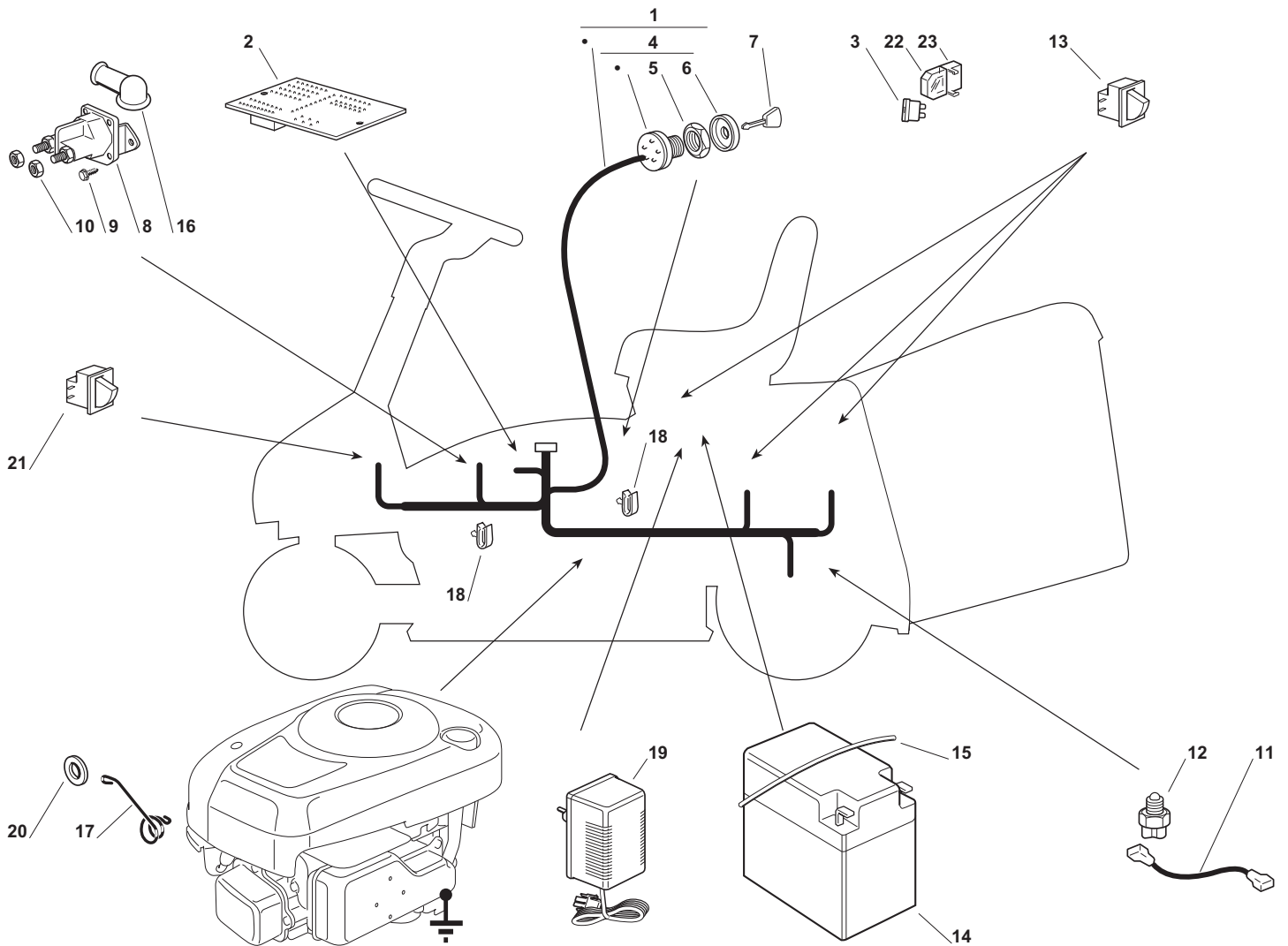

Seite / Page	Pos.	Teil-Nr. Part No. No. de pièce No. de pieza	Hinweise Notes Renseign. Nota	Bezeichnung	Spezifikation Specification	Description	Désignation	Denominación
11	*	x		ZUM AUSTAUSCH DER MIT «*» GEKENNZEICHNETEN TEILE, WENDEN SIE SICH AN DEN KUNDENDIENST DES MOTORHERSTELLERS		TO REPLACE THE PARTS MARKED «*» SEEK ASSISTANCE FROM THE ENGINE MANUFACTURER'S AFTER SALES SERVICE.	POUR LE REMPLACEMENT DES PIÈCES MARQUÉES AVEC «*» S'ADRESSER AU SERVICE APRÈS VENTES DU CONSTRUCTEUR DU MOTEUR.	PARA RECAMBIO DE LAS PIEZAS MARCADO CON «*» FAVOR SE DIRIGEN AL SERVICIO TÉCNICO DEL FABRICANTE DEL MOTOR.
11	1	1 664 040 123		KABELSATZ		CABLES	CABLAGES	CABLEADO
11	2	1 664 722 354		ELEKTRONISCHE KARTE		ELECTRONIC CARD	CARTE ELECTRONIQUE	TARJETA ELECTRÓNICA
11	3	1 664 340 040		SICHERUNG		FUSE	FUSIBLE	FUSIBLE
11	4	1 664 450 065		SCHALTER		STARTING SWITCH	INTERRUPTEUR DEMARRAGE	INTERRUPTOR DE ENCENDIDO
11	5	1 664 400 861		NUTMUTTER		RING NUT	EMBOUT	TUERCA RANURADA
11	6	1 664 565 351		NUTMUTTER SCHUTZ		SCREWED RING PROTECTION	PROTECTION EMBOUT	PROTECCIÓN TUERCA RANURADA
11	7	1 664 210 016		SCHLÜSSEL FÜR START		STARTING KEY	CLEF A DEMARRAGE	LLAVE DE ENCENDIDO
11	8	1 664 736 111		ANLASSRELAIS		STARTER RELAY	RELAIS D'ALLUMAGE	RELÉ DE ARRANQUE
11	9	2 664 735 110		SCHRAUBE		SCREW	VIS	TORNILLO
11	10	2 664 360 352		MUTTER		NUT	ECROU	TUERCA
11	11	1 664 065 060		KABEL		CABLE	CÂBLE	CABLE
11	12	1 664 700 046		SCHALTER, ANTRIEB		SWITCH	INTERRUPTEUR	INTERRUPTOR
11	13	3 664 410 606		MIKROSCHALTER		MICROSWITCH	MICROINTERRUPTEUR	MICROINTERRUPTOR
11	14	1 664 120 004		BATTERIE		BATTERY	BATTERIE	BATERÍA
11	15	1 664 430 572		FEDER		SPRING	RESSORT	MUELLE
11	16	1 664 564 861		STECKER		PROTECTION	CAPUCHON	CAPUCHÓN
11	17	1 664 340 557		FEDER		SPRING	RESSORT	MUELLE
11	18	5 664 320 506		KABELBEFESTIGUNG		FAIRLEAD	FIXATION CABLE	SUJETACABLE
11	19	1 664 180 053		BATTERIELADEGERÄT	UK	BATTERY CHARGER	CHARGEUR DE BATTERIES	CARGADOR DE BATERÍAS
11	19	1 664 180 051		BATTERIELADEGERÄT	DE	BATTERY CHARGER	CHARGEUR DE BATTERIES	CARGADOR DE BATERÍAS
11	20	1 664 523 020		SCHEIBE		WASHER	RONDELLE	ARANDELA
11	21	1 664 410 612		MIKROSCHALTER		MICROSWITCH	MICROINTERRUPTEUR	MICROINTERRUPTOR
11	22	1 664 215 000		DECKEL		COVER	COUVERCLE	CUBIERTA
11	23	1 664 500 007		SICHERUNGHALTER		FUSE CARRIER	TABLEAU DE FUSIBLE	SOPORTE

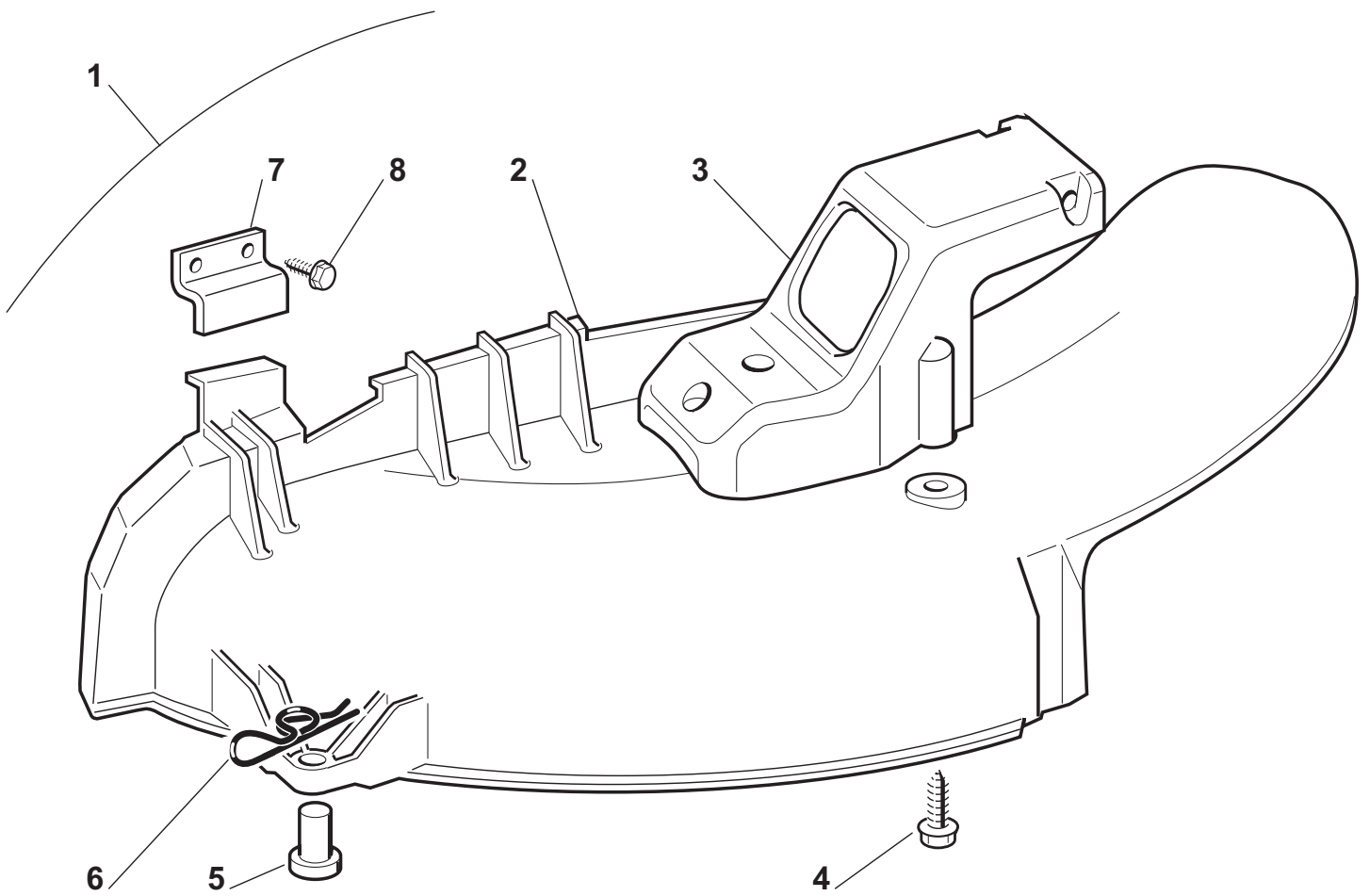

Seite / Page	Pos.	RM-63.7	Teil-Nr. Part No. No. de pièce No. de pieza	Hinweise Notes Renseign. Nota	Bezeichnung	Spezifikation Specification	Description	Désignation	Denominación
12	1	1	664 900 042		MULCHKEIL		MULCHING KIT	KIT MULCHING	JUEGO DE ACOLCHONAMIENTO
12	2	1	664 140 052		ABWEISER		DEFLECTOR	DEFLECTEUR	DEFLECTOR
12	3	1	664 230 201		GELENKPUNKT		FULCRUM PIN	POINT D'APPUI	PUNTO DE ARTICULACIÓN
12	4	3	664 735 410		SCHRAUBE		SCREW	VIS	TORNILLO
12	5	1	664 510 022		BOLZEN		PIN	PIVOT	PIVOTE
12	6	1	664 487 997		SPLINT		COTTER PIN	GOUPILLE	PASADOR
12	7	1	664 772 139		HALTER		CLAMP	ETRIER	SOPORTE
12	8	2	664 735 110		SCHRAUBE		SCREW	VIS	TORNILLO

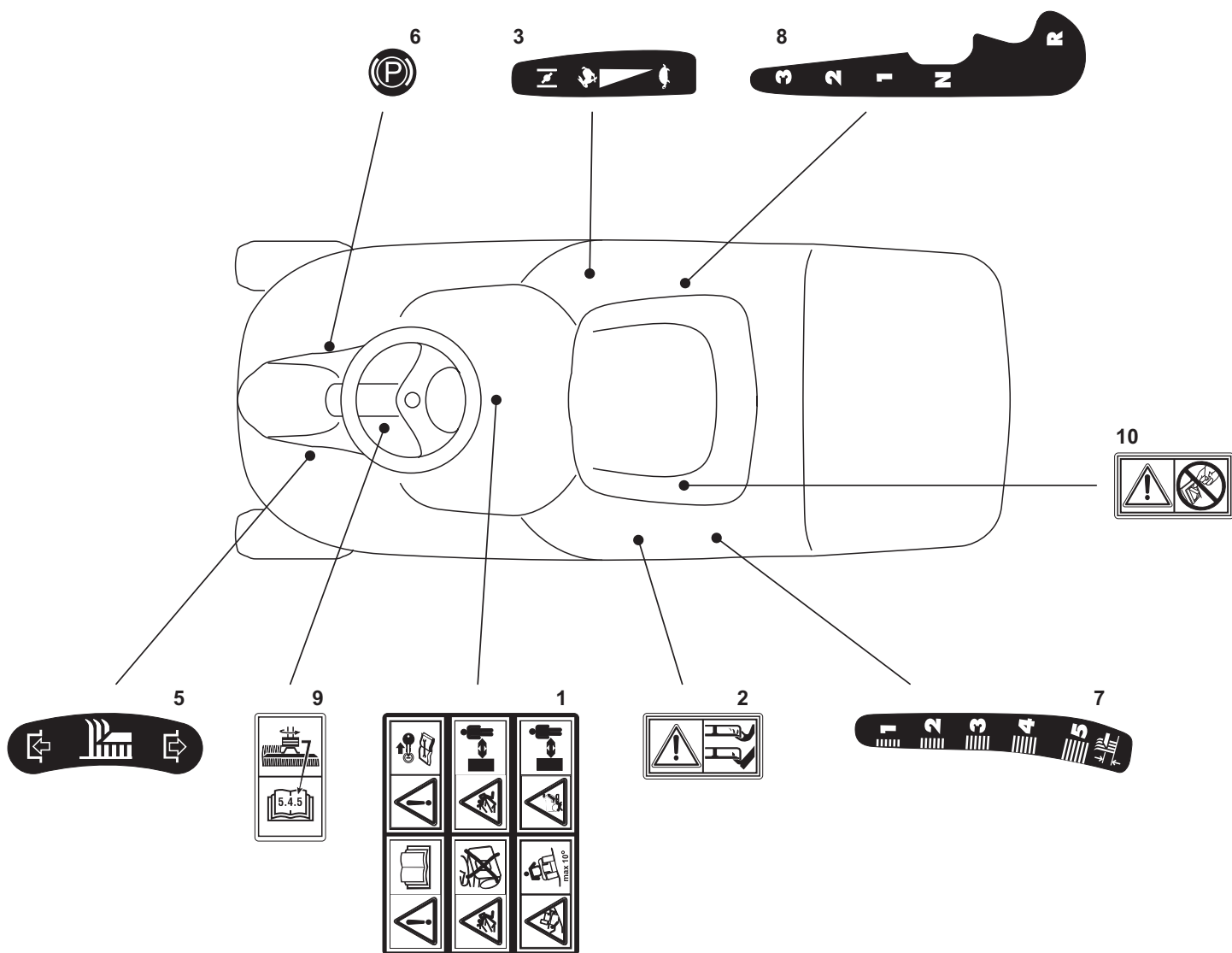

Seite / Page	Pos.	RM-63.7	Teil-Nr. Part No. No. de pièce No. de pieza	Hinweise Notes Renseign. Nota	Bezeichnung	Spezifikation Specification	Description	Désignation	Denominación
13	1	1	664 357 428		SCHILD		LABEL	ETIQUETTE	ETIQUETA
13	2	1	664 356 699		SCHILD		LABEL	ETIQUETTE	ETIQUETA
13	3	1	664 358 415		SCHILD		LABEL	ETIQUETTE	ETIQUETA
13	5	1	664 358 418		SCHILD		LABEL	ETIQUETTE	ETIQUETA
13	6	1	664 358 460		SCHILD		LABEL	ETIQUETTE	ETIQUETA
13	7	1	664 358 417		SCHILD		LABEL	ETIQUETTE	ETIQUETA
13	8	1	664 358 416		SCHILD		LABEL	ETIQUETTE	ETIQUETA
13	9	1	664 358 654		SCHILD		LABEL	ETIQUETTE	ETIQUETA
13	10	1	664 360 118		SCHILD		LABEL	ETIQUETTE	ETIQUETA

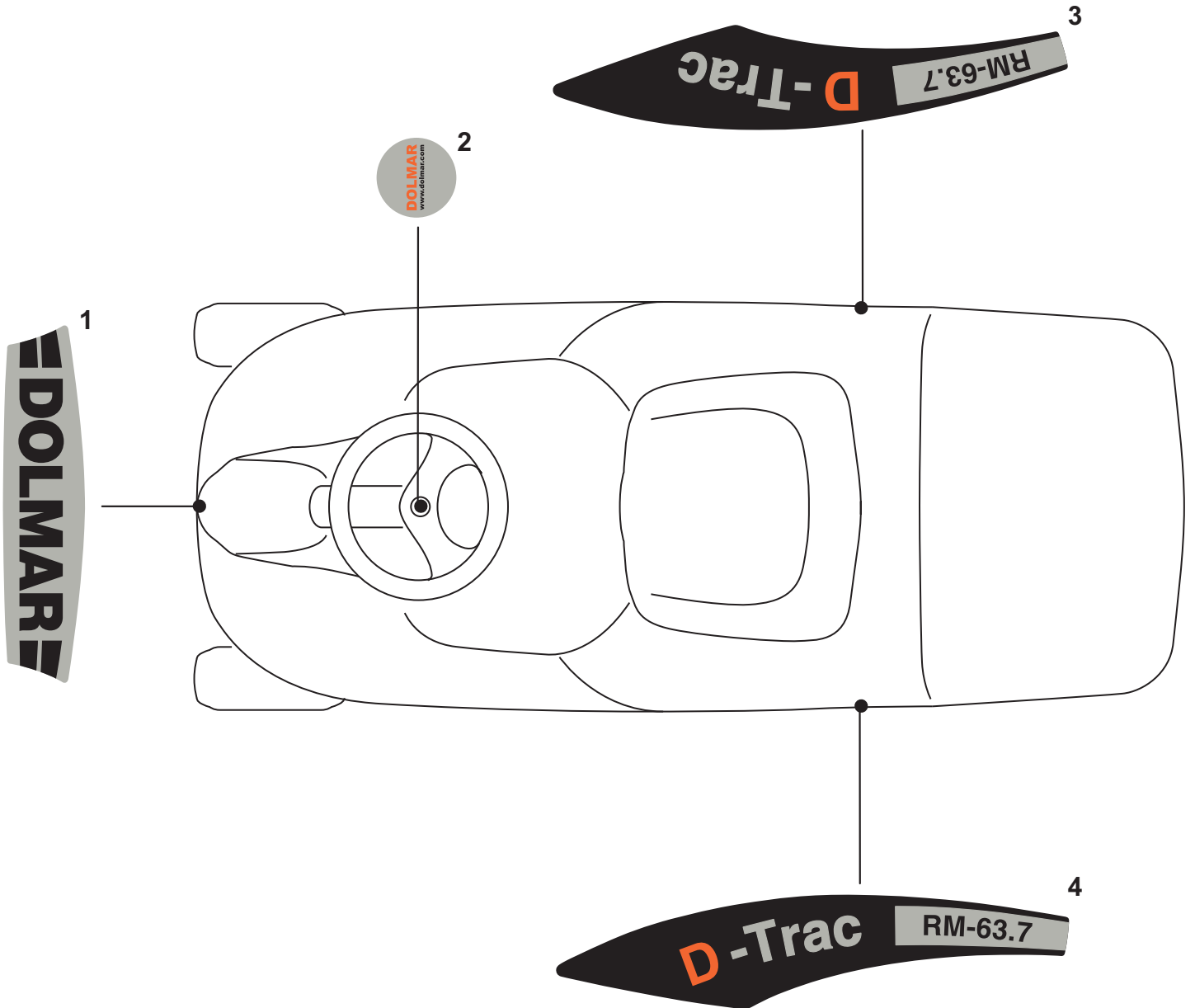

(2009) RM-63.7

14

AUFKLEBER
LABELS
ETIQUETTES
ETIQUETA



Seite / Page	Pos.	RM-63.7	Teil-Nr. Part No. No. de pièce No. de pieza	Hinweise Notes Renseign. Nota	Bezeichnung	Spezifikation Specification	Description	Désignation	Denominación
14	1	1	664 362 502		SCHILD		LABEL	ETIQUETTE	ETIQUETA
14	2	1	664 361 485		SCHILD		LABEL	ETIQUETTE	ETIQUETA
14	3	1	664 362 503		SCHILD		LABEL	ETIQUETTE	ETIQUETA
14	4	1	664 362 504		SCHILD		LABEL	ETIQUETTE	ETIQUETA

1	RAHMENSATZ CHASSIS CHASSIS CHASIS	11	ELEKTRISCHE TEILE ELECTRICAL PARTS PIECES ELECTRIQUES PARTES ELÉCTRICAS
2	KARROSSERIE BODY CARROSSERIE CARROCERÍA	12	ZUBEHÖR NACH ANFRAGE OPTIONALS ON REQUEST ACCESSOIRES SUR DEMANDE ACCESORIO BAJO DEMANDA
3	LENKGETRIEBE STEERING BARRE DE DIRECTION BARRA DE DIRECCIÓN	13	AUFKLEBER LABELS ETIQUETTES ETIQUETA
4	GETRIEBE UND BREMSE ANTRIEB DRIVE AND BRAKE CONTROLS COMMANDE TRANSMISSION ET FREIN ACCIONAMIENTO TRANSMISIÓN Y FRENOS	14	AUFKLEBER LABELS ETIQUETTES ETIQUETA
5	Motor Motor Moteur Motor		
6	Getriebe Gear Engrenage Engranaje		
7	SCHNEIDWERKZEUG AUFHEBESATZ CUTTING PLATE LIFTING SOULEVEMENT PLATEAU DE COUPE HERRAMIENTA DE CORTE PLATO DE ELEVACIÓN		
8	SCHNEIDWERKZEUG (1) CUTTING PLATE (1) PLATEAU DE COUPE (1) HERRAMIENTA DE CORTE (1)		
9	SCHNEIDWERKZEUG (2) CUTTING PLATE (2) PLATEAU DE COUPE (2) HERRAMIENTA DE CORTE (2)		
10	GRASS-SACK GRASSCATCHER BAC CESTO		

	Zeichenerklärung	Key to symbols
=> 1999999 2000000 => 2003.04 => TI 2003/07 Acc. = { m Corr.	Produktion bis Serien-Nr. Neues Teil ab Serien-Nr. Neues Teil ab Jahr / Monat Siehe Technische Information Jahr / Nr. Zubehör (nicht im Lieferumfang) Keine Serienausführung, jedoch verwendbar Beinhaltet Positions-Nr. Meterware Druckfehlerberichtigung	Production to serial number New part from serial number New part from Year / Month See Technical Information Year / No. Accessories (not included in the delivery inventory) No standard execution, may be used Contains item number Sold by the meter Error correction
	Änderungen vorbehalten	Specifications subject to change without notice
	Légende	Explicación de símbolos
=> 1999999 2000000 => 2003.04 => TI 2003/07 Acc. = { m Corr.	Production jusqu'à n° de série Nouveau pièce à partir du n° de série Nouveau pièce à partir de année / mois Voir information technique année / n° Accessoires (non compris dans la livraison) Aucune exécut. en série, cependant utilisable contient n° de numéro Au mètre Rectification d'erreurs	Producción hasta N° de serie Pieza nueva a partir de N° de serie Pieza nueva a partir de año / mes Véase inform. técnico año / N° Accesorios (no incluido en la extensión del suministro) No es de serie, pero sirve Contiene pos N° Por metro Fe de erratas
	Changements sans préavis	Mejoras constructivas sin previo aviso