

Spare Parts List  
Ersatzteilliste  
Liste de pièces détachées  
Lista de piezas de repuesto

2010-07

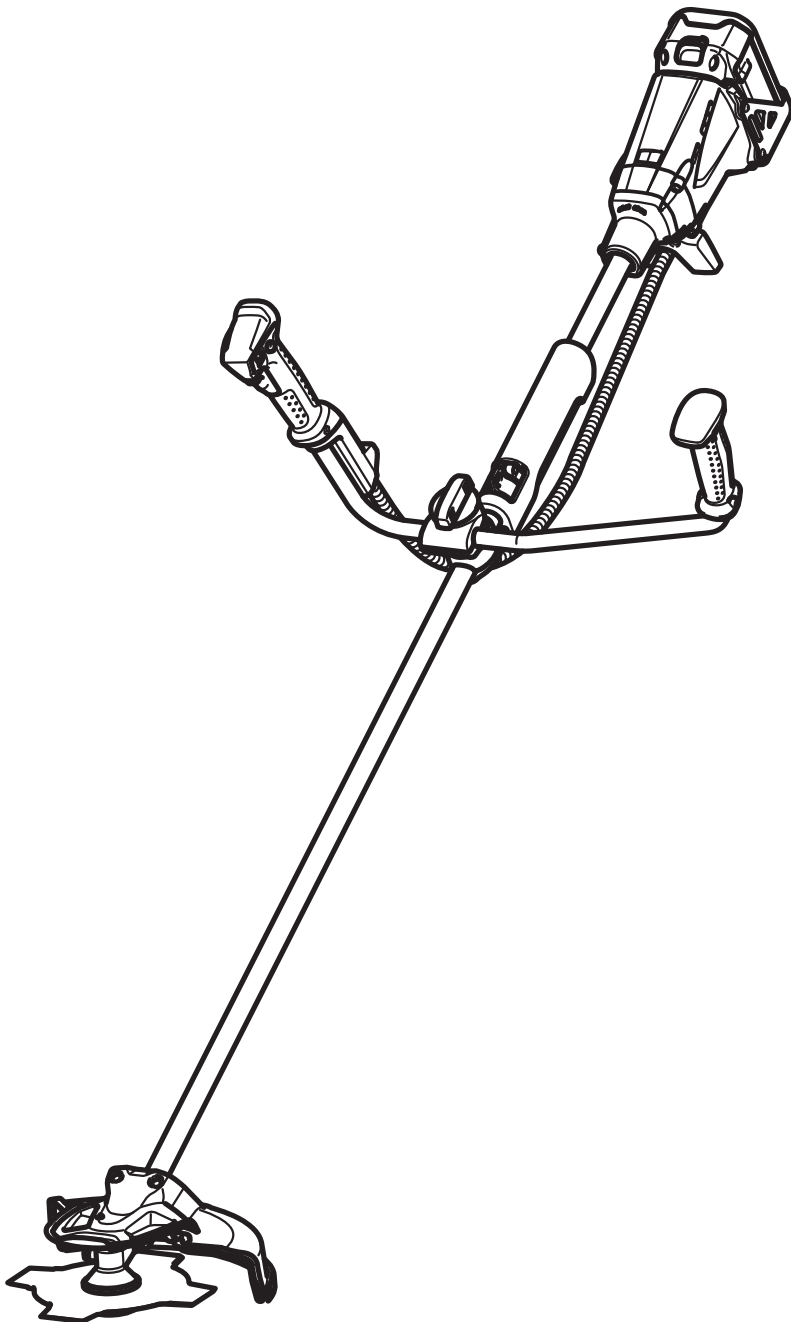

AT-3623 / LGE

**DOLMAR**



A member of the *Makita* Group

995700282 (D, GB, F, E)

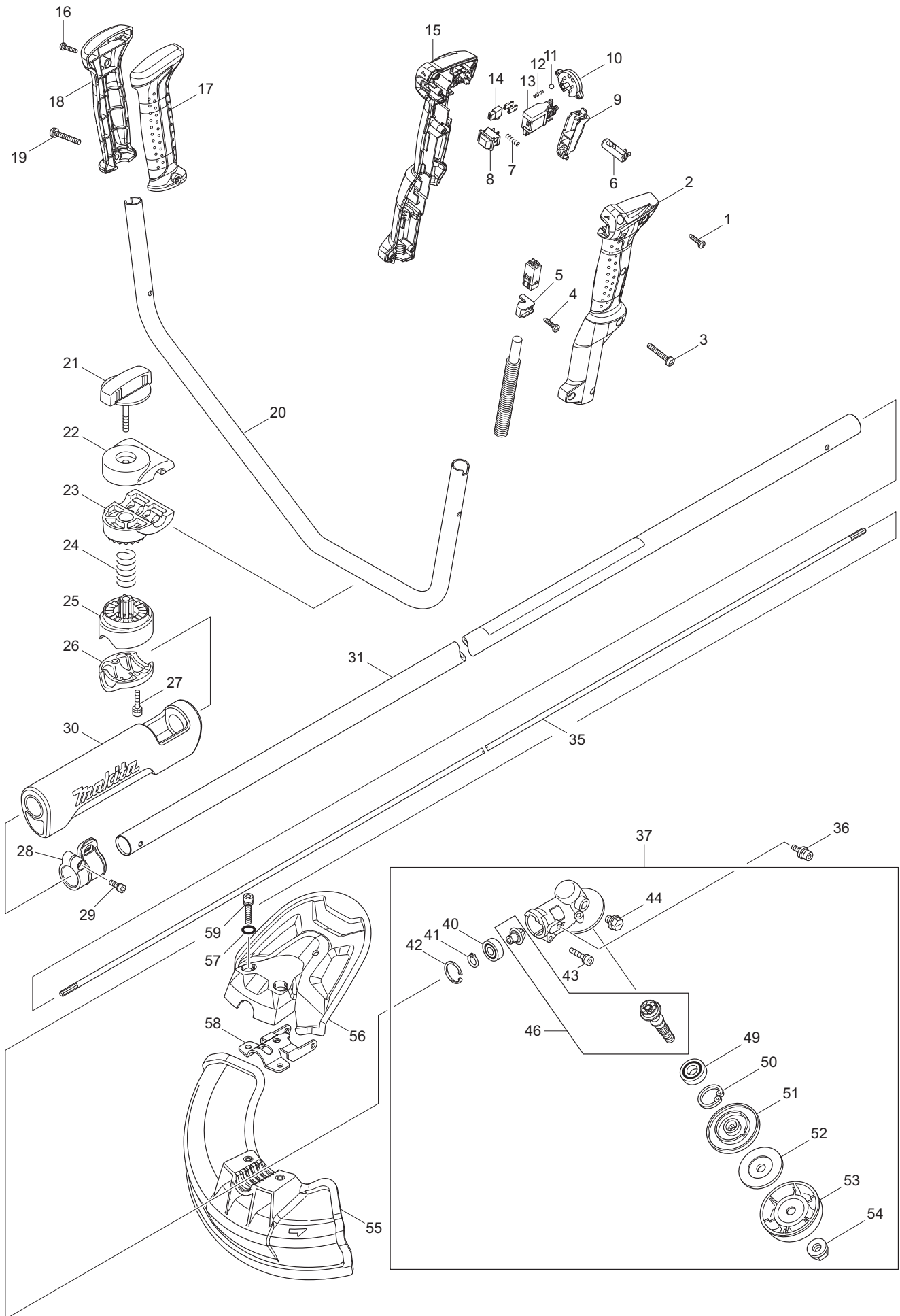

Seite / Page	Pos.	AT-3623 / LGE	Teil-Nr. Part No. No. de pièce No. de pieza	Hinweise Notes Renseign. Nota	Bezeichnung	Spezifikation Specification	Description	Désignation	Denominación
1	1	6	660 265 995		GEWINDESCHNEIDS CHRAUBE	4X18	TAPPING SCREW	VIS TARAUEUSE	TORNILLO DE ROSCA CORTANTE
1	2	1	660 188 839		GRIFFSCHALEN, SATZ	INC. 2, 15	MAIN GRIP SET	POIGNÉE, JEU	MANGO, JUEGO
1	3	1	660 911 256		FLACHKOPFSCHRAU BE	M5X35	PAN HEAD SCREW	VIS À TÊTE CYLINDRIQUE	TORNILLO DE CABEZA PLANA
1	4	1	660 265 995		GEWINDESCHNEIDS CHRAUBE	4X18	TAPPING SCREW	VIS TARAUEUSE	TORNILLO DE ROSCA CORTANTE
1	5	1	660 687 261		ZUGENTLASTUNG KABEL		STRAIN RELIEF CABLE	DÉCONTRACTION CÂBLE	CABLE DESCARGA DE TRACCIÓN
1	6	1	660 451 571		SPERRKNOPF		LOCK OFF BUTTON	BOUTON DE BLOCAGE	BOTON DE BLOQUEO
1	7	1	660 231 473		DRUCKFEDER	4	COMPRESSION SPRING	RESSORT DE PRESSION	MUELLE DE COMPRESIÓN
1	8	1	660 651 533		SCHALTER	SLE6A2-33	SWITCH	INTERRUPTEUR	INTERRUPTOR
1	9	1	660 451 573		SCHALTHEBEL		SWITCH LEVER	LEVIER DU COUPE CIRCUIT	MANO INTERRUPTOR
1	10	1	660 451 574		ANZEIGE		INDICATOR	INDICATEUR	INDICADOR
1	11	1	660 216 018		STAHLKUGEL	5.0	STEEL BALL	BILLE D ARRET	BOLA DE TOPE
1	12	1	660 233 211		DRUCKFEDER	2	COMPRESSION SPRING	RESSORT DE PRESSION	MUELLE DE COMPRESIÓN
1	13	1	660 650 629		SCHALTER	TGR3-2	SWITCH	INTERRUPTEUR	INTERRUPTOR
1	14	1	660 686 015		STECKERHÜLSE		RECEPTACLE SLEEVE	CONNECTEUR	CONECTOR ENCHUFABLE
1	15	1	660 188 839		GRIFFSCHALEN, SATZ	INC. 2, 15	MAIN GRIP SET	POIGNÉE, JEU	MANGO, JUEGO
1	16	1	660 265 995		GEWINDESCHNEIDS CHRAUBE	4X18	TAPPING SCREW	VIS TARAUEUSE	TORNILLO DE ROSCA CORTANTE
1	17	1	367 188 659		GRIFFSCHALEN, SATZ	INC. 17, 18	GRIP, SET	POIGNÉE, JEU	MANGO, JUEGO
1	18	1	367 188 659		GRIFFSCHALEN, SATZ	INC. 17, 18	GRIP, SET	POIGNÉE, JEU	MANGO, JUEGO
1	19	1	660 911 256		FLACHKOPFSCHRAU BE	M5X35	PAN HEAD SCREW	VIS À TÊTE CYLINDRIQUE	TORNILLO DE CABEZA PLANA
1	20	1	367 331 862		GRIFFROHR	19	HANDLE	TUBE DE POIGNÉE	TUBO DE MANGO
1	21	1	367 168 524		KNOPF	57	KNOB	BOUTON	BOTÓN
1	22	1	367 318 429		KLEMMSCHELLE		HANDLE CLAMP	COLLIER DE SERRAGE	ABRAZADERA DE SUJECIÓN
1	23	1	367 318 428		HANDGRIFFHALTER		HANDLE HOLDER	DEPOSITIF DE SERRAGE	SOPORTE PRESOR
1	24	1	367 233 202		DRUCKFEDER	20	COMPRESSION SPRING	RESSORT DE PRESSION	MUELLE DE COMPRESIÓN
1	25	1	367 318 427		KLEMMSCHALE		PIPE HOLDER	DISP. DE SERRAGE	SOPORTE PRESOR
1	26	1	367 318 426		KLEMMSCHELLE		PIPE CLAMP	COLLIER DE SERRAGE	ABRAZADERA DE SUJECIÓN
1	27	2	367 922 241		SCHRAUBE	M5X25	HEX. SOCKET HEAD BOLT	VIS HEXAGONAL	TORNILLO HEXAGONAL
1	28	1	660 168 478		TRAGEGURTAUFNAH ME		HANGER	ATTACHE DE BRETTELLE	SUJECIÓN
1	29	1	367 922 228		SCHRAUBE	5X18	H.S.H.BOLT WITH WR	VIS	TORNILLO
1	30	1	660 424 291		HÜFTSCHUTZ		CUSHION	PROTECTEUR DE HANCHE	PROTECCION DE LA CADERA
1	31	1	660 140 284		SCHAFTROHR KPL.		SHAFT PIPE COMPLETE	TUBE PRINCIPAL CPL.	TUBO PRINCIPAL CPL.
1	31	1	660 810 558		SICHERHEITSAUFKL EBER		CAUTION LABEL	PLAQUE	CALCOMANIA
1	35	1	660 325 812		WELLE		SHAFT	ARBRE	ÁRBOL
1	36	2	367 922 218		SCHRAUBE	M5X14	H.S.H.BOLT WITH WR	VIS	TORNILLO
1	37	1	367 125 556		GETRIEBEGEHÄUSE KPL.	INC. 40-44,46,49-54	GEAR CASE ASS'Y	CARTER D'ENGRENAGES CPL.	CAJA DE ENGRANAJES CPL.
1	40	1	367 210 049		KUGELLAGER	609ZZ	BALL BEARING	ROULEMENT À BILLES	RODAMIENTO DE BOLAS

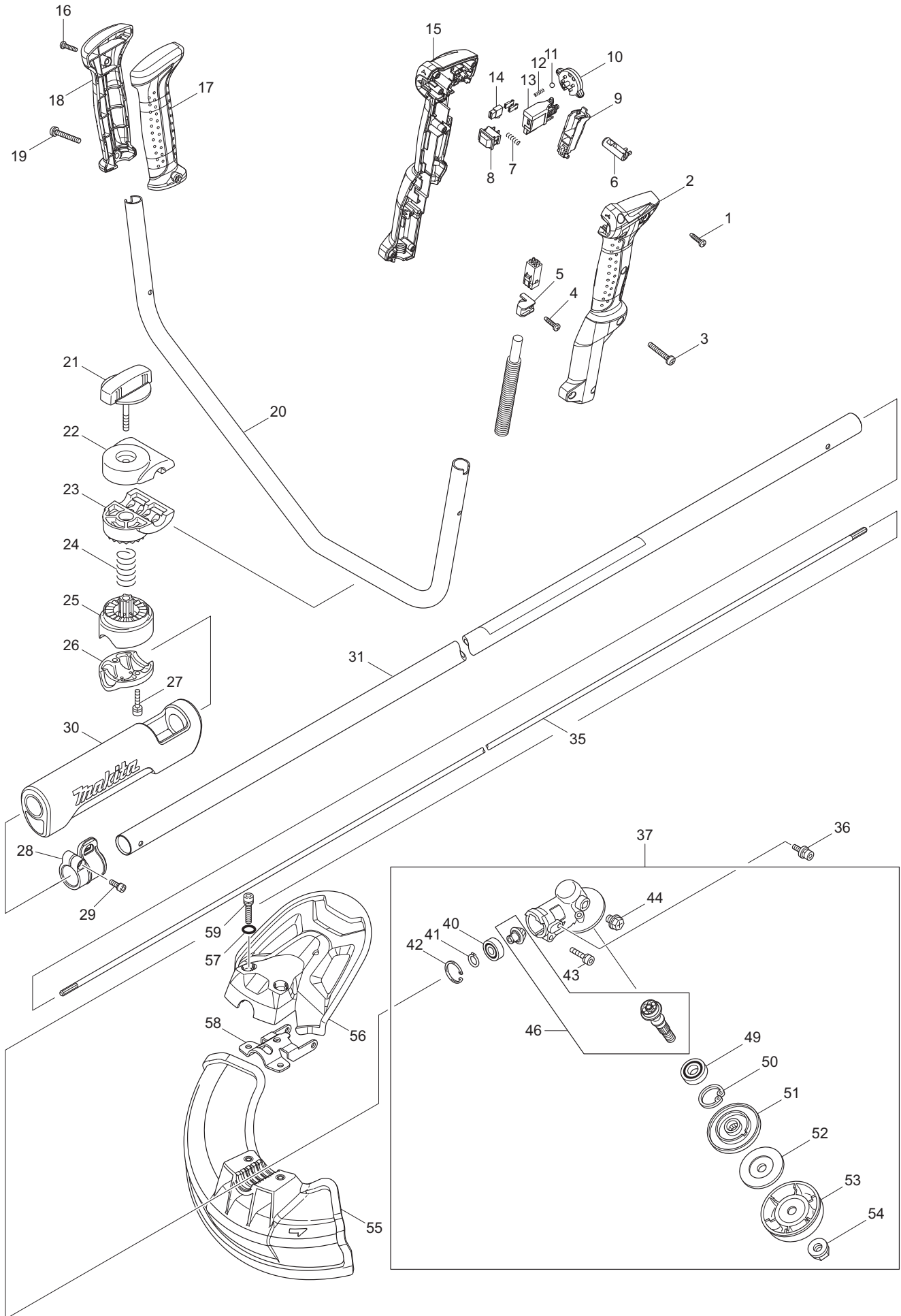

Seite / Page	Pos.	AT-3623 / LGE	Teil-Nr. Part No. No. de pièce No. de pieza	Hinweise Notes Renseign. Nota	Bezeichnung	Spezifikation Specification	Description	Désignation	Denominación
1	41	1	367 961 005		SICHERUNGSRING	S-9	RETAINING RING	CIRCLIP	ANILLO SEGURIDAD
1	42	1	367 962 103		SICHERUNGSRING	R-24	RETAINING RING	CIRCLIP	ANILLO SEGURIDAD
1	43	1	367 922 241		SCHRAUBE	M5X25	HEX. SOCKET HEAD BOLT	VIS HEXAGONAL	TORNILLO HEXAGONAL
1	44	1	367 265 590		SCHRAUBE	M8X10	+HEX.BOLT WITH R	VIS HEXAGONAL	TORNILLO HEXAGONAL
1	46	1	660 188 902		GETRIEBERÄDER KPL.		CUTTER SHAFT SET	ROUES D'ENGRENAGES CPL.	RUEDAS DE ENGRANAJEW CPL.
1	49	1	367 210 115		KUGELLAGER	6001LLU	BALL BEARING	ROULEMENT À BILLES	RODAMIENTO DE BOLAS
1	50	1	367 962 106		SICHERUNGSRING	R-28	RETAINING RING	CIRCLIP	ANILLO SEGURIDAD
1	51	1	367 331 861		AUFNAHMESCHEIBE		RECEIVE WASHER	DISQUE DE SUPPORT	DISCO DE SUJECIÓN
1	52	1	367 346 084		DRUCKSCHEIBE		CLAMP WASHER	JEU DISQUE DE PRESSION CPL.	JUEGO DISCO DE PRESION
1	53	1	367 168 526		GLEITTELLER		SLIDING CUP	BOL DE GLISSEMENT	PLATO DESLIZANTE
1	54	1	367 264 025		SECHSKANTMUTTER	M10-17	HEX NUT	ECROU HEXAGONAL	TUERCA HEXAGONAL
1	55	1	660 451 566		SCHUTZHAUBE		PROTECTOR	CAPOT DE PROTECTION	CUBIERTA PROTECTORA
1	56	1	660 451 565		ABDECKUNG		PROTECTOR COVER	COUVERCLE	CUBIERTA
1	57	2	660 213 105		O-RING	11	O RING	ANNEAU TORIQUE	ANILLO OBTURADOR
1	58	1	367 346 073		SHELLE FÜR SCHUTZHAUBE		PROTECTOR CLAMP	COLLIER	ABRAZADERA
1	59	2	367 922 353		SCHRAUBE	M6X30	HEX. SOCKET HEAD BOLT	VIS HEXAGONAL	TORNILLO HEXAGONAL

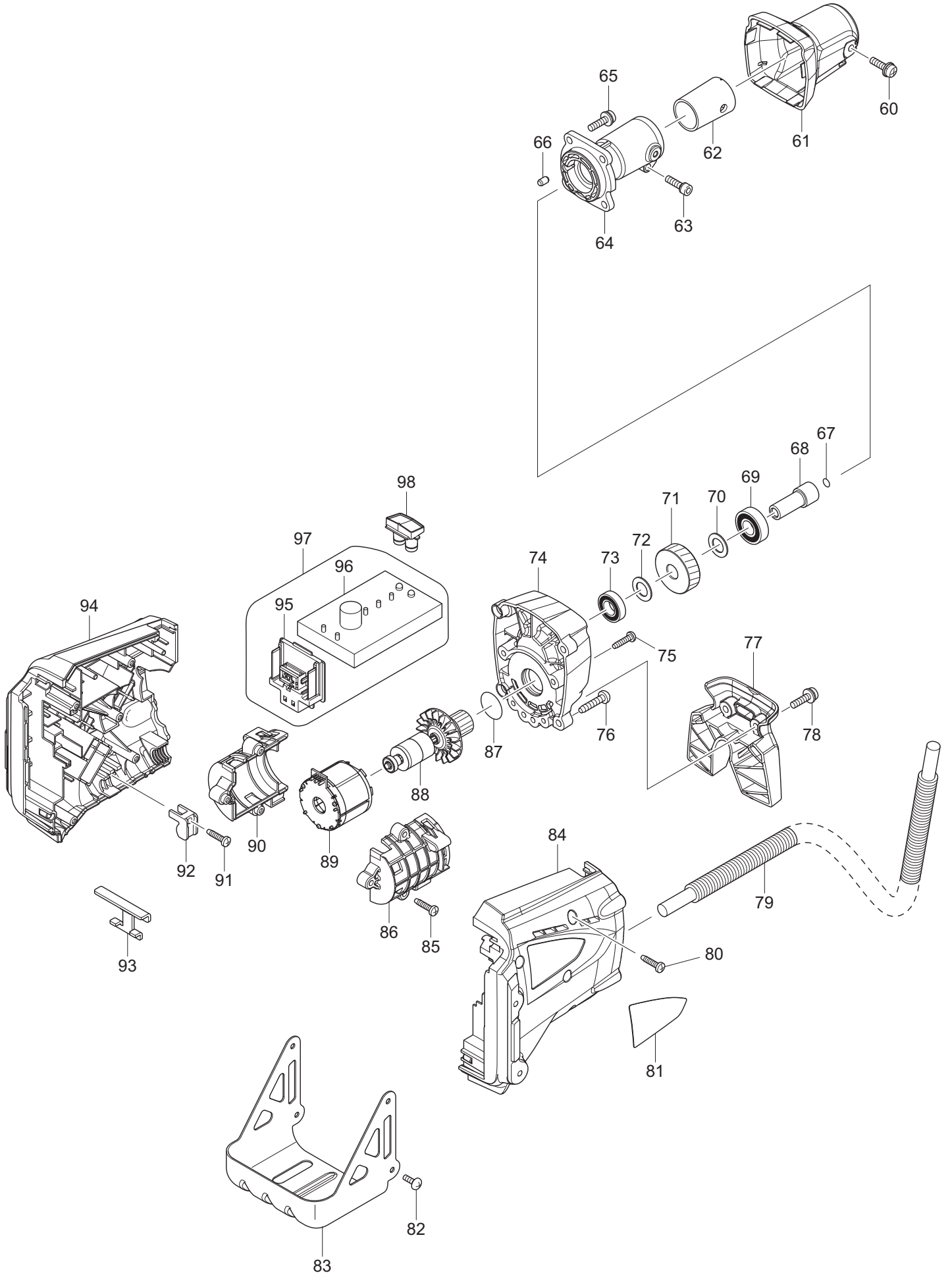

Seite / Page	Pos.	AT-3623 / LGE	Teil-Nr. Part No. No. de pièce No. de pieza	Hinweise Notes Renseign. Nota	Bezeichnung	Spezifikation Specification	Description	Désignation	Denominación
2	60	1	367 911 233		FLACHKOPFSCHRAUBE	M5X20	PAN HEAD SCREW	VIS À TÊTE CYLINDRIQUE	TORNILLO DE CABEZA PLANA
2	61	1	660 451 578		GEHÄUSE		PIPE BRACKET COVER	CARTER	CÁRTER
2	62	1	660 424 307		GUMMIDÄMPFER		PIPE RUBBER	AMORTISSEUR DE VIBRATIONS	AMORTIGUADOR DE VIBRACIONES
2	63	1	320 922 231		SCHRAUBE	M5X20	HEX. SOCKET HEAD BOLT	VIS	TORNILLO
2	64	1	660 318 560		SCHAFTAUFNAHME		PIPE BRACKET	SUPPORT	SOPORTE
2	65	4	367 911 233		FLACHKOPFSCHRAUBE	M5X20	PAN HEAD SCREW	VIS À TÊTE CYLINDRIQUE	TORNILLO DE CABEZA PLANA
2	66	1	660 263 002		GUMMISTIFT	4	RUBBER PIN	CHEVILLE EN CAOUTCHOUC	ESPIGA DE GOMA
2	67	1	660 213 045		O-RING	6	O RING	ANNEAU TORIQUE	ANILLO OBTURADOR
2	68	1	660 325 811		SPINDEL		SPINDLE HUB	FUSEAU	HUSILLO
2	69	1	660 211 148		KUGELLAGER	6001ZZ	BALL BEARING	ROULEMENT À BILLES	RODAMIENTO DE BOLAS
2	70	1	660 253 744		FLACHSCHEIBE	12	FLAT WASHER	RONDELLE PLATE	ARANDELA
2	71	1	660 227 720		SCHRÄGSTIRNRAD	33	HELICAL GEAR	ROUE HÉLICOÏDALE	RUEDA HELICOIDAL
2	72	1	660 253 744		FLACHSCHEIBE	12	FLAT WASHER	RONDELLE PLATE	ARANDELA
2	73	1	660 211 150		KUGELLAGER	6901ZZ	BALL BEARING	ROULEMENT À BILLES	RODAMIENTO DE BOLAS
2	74	1	660 318 559		GETRIEBEGEHÄUSE		GEAR BOX	CARTER D'ENGRENAGES	CAJA DE ENGRANAJES
2	75	4	660 265 995		GEWINDESCHNEIDSC HRAUBE	4X18	TAPPING SCREW	VIS TARAUEUSE	TORNILLO DE ROSCA CORTANTE
2	76	4	660 266 041		SCHNEIDSCHRAUBE	5X25	TAPPING SCREW	VIS TARAUEUSE	TORNILLO DE ROSCA CORTANTE
2	77	1	660 451 572		STÄNDER		STAND	COLONNE	BASTIDOR
2	78	2	367 911 233		FLACHKOPFSCHRAUBE	M5X20	PAN HEAD SCREW	VIS À TÊTE CYLINDRIQUE	TORNILLO DE CABEZA PLANA
2	79	1	660 699 045		KABEL		POWER SUPPLY CORD UNIT	CÂBLE	CABLE
2	80	5	660 265 995		GEWINDESCHNEIDSC HRAUBE	4X18	TAPPING SCREW	VIS TARAUEUSE	TORNILLO DE ROSCA CORTANTE
2	81	1	660 867 946		SCHILD	AT-3623	NAME PLATE	PLAQUE	PLACA
2	82	4	660 251 314		SCHRAUBE	M4X12	SCREW	VIS	TORNILLO
2	83	1	660 346 194		BATTERIESCHUTZ		BATTERY GUARD	PROTECTION	PROTECTOR
2	84	1	660 188 837		GEHÄUSE SATZ	INC. 84, 94	HOUSING SET	CARTER, JEU	CÁRTER, JUEGO
2	85	3	660 265 995		GEWINDESCHNEIDSC HRAUBE	4X18	TAPPING SCREW	VIS TARAUEUSE	TORNILLO DE ROSCA CORTANTE
2	86	1	660 188 838		MOTORGEHÄUSE KPL.	INC. 86, 90	MOTOR HOUSING SET	CARTER MOTEUR CPL.	CÁRTER MOTOR CPL.
2	87	1	660 213 961		O-RING	22	O RING	ANNEAU TORIQUE	ANILLO OBTURADOR
2	88	1	660 619 254		ROTOR KPL.		ROTOR ASSY.	ROTOR CPL.	ROTOR CPL.
2	89	1	660 629 880		STATOR KPL.		STATOR ASSY.	STATOR CPL.	ESTATOR CPL.
2	90	1	660 188 838		MOTORGEHÄUSE KPL.	INC. 86, 90	MOTOR HOUSING SET	CARTER MOTEUR CPL.	CÁRTER MOTOR CPL.
2	91	1	660 265 995		GEWINDESCHNEIDSC HRAUBE	4X18	TAPPING SCREW	VIS TARAUEUSE	TORNILLO DE ROSCA CORTANTE
2	92	1	660 687 261		ZUGENTLASTUNG KABEL		STRAIN RELIEF CABLE	DÉCONTRACTION CÂBLE	CABLE DESCARGA DE TRACCIÓN
2	93	1	660 346 039		STÜTZBLECH		SUPPORT PLATE	TÔLE SUPPORT	CHAPA DE APOYO
2	94	1	660 188 837		GEHÄUSE SATZ	INC. 84, 94	HOUSING SET	CARTER, JEU	CÁRTER, JUEGO
2	95	1	660 643 849		ANSCHLUSSKLEMME		TERMINAL	BORNE	BORNE
2	96	1	660 631 942		CONTROLLER		CONTROLLER	CONTRÔLEUR	CONTROLADOR
2	97	1	660 631 941		CONTROLLER KPL.	INC. 95,96	CONTROLLER COMPLETE	CONTRÔLEUR CPL.	CONTROLADOR CPL.
2	98	1	660 140 285		HINWEISSCHILD KPL.		INDICATION PLATE COMPLETE	PLAQUE CPL.	CALCOMANIA CPL.



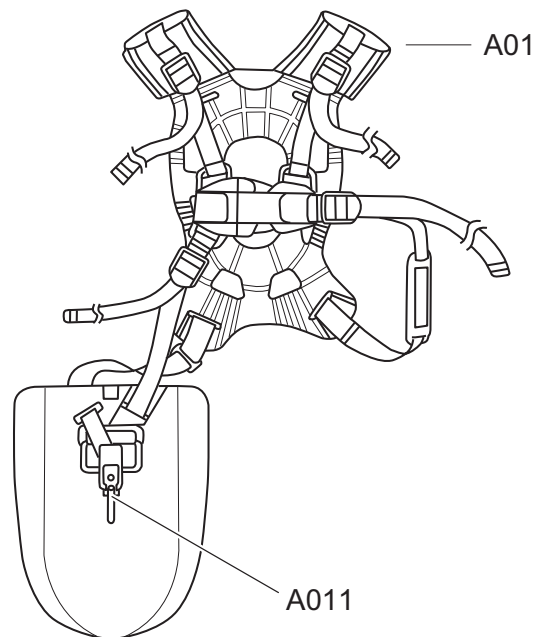
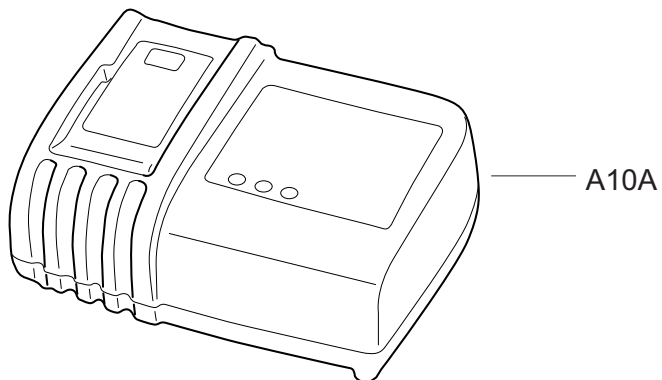
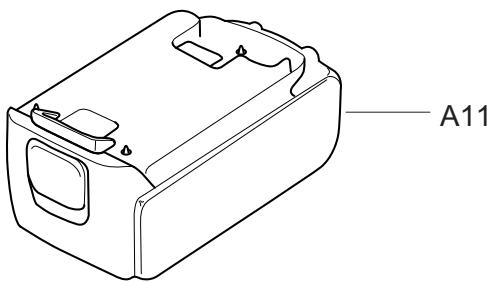
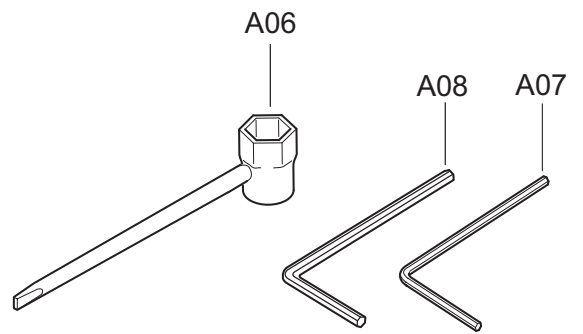
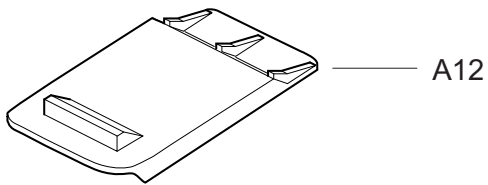
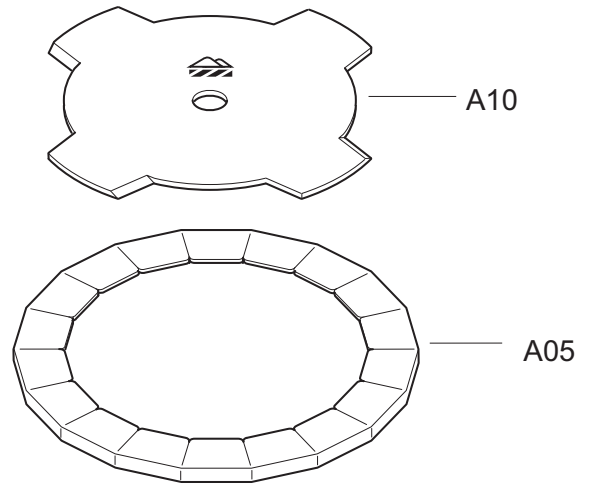
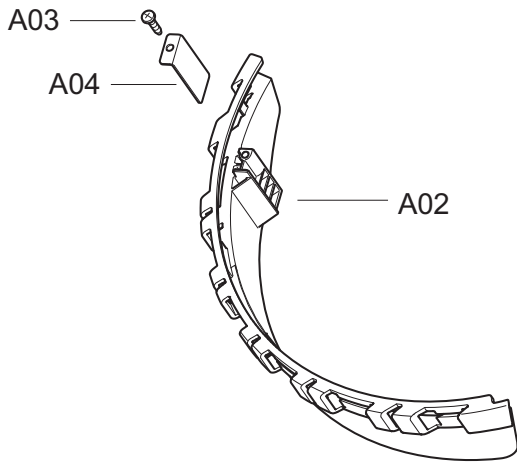



Seite / Page	Pos.	AT-3623 / LGE	Teil-Nr. Part No. No. de pièce No. de pieza	Hinweise Notes Renseign. Nota	Bezeichnung	Spezifikation Specification	Description	Désignation	Denominación
3	A01	1	367 122 907		SCHULTERGURT KPL.		BAND ASS'Y	BRETELLE	HARNESS
3	A01 1	1	377 140 400		KARABINERHAKEN		SNAPHOOK	PORTE-MOUSQUET ON	PORTA-CARABINA
3	A02	1	660 140 583		SCHUTZLEISTE		PROTECTOR EXTENSION COMPLETE	BARRE DE PROTECTION	BARRA DE PROTECCIÓN
3	A02	1			HINWEISSCHILD		INDICATION LABEL	PLAQUE	ETIQUETA DE INDICACIÓN
3	A03	1	660 265 995		GEWINDESCHNEIDS CHRAUBE	4X18	TAPPING SCREW	VIS TARAUDEUSE	TORNILLO DE ROSCA CORTANTE
3	A04	1	660 346 280		FADENMESSER		LINE CUTTER	COUPEAU DE FIL	CUCHILLA DE HILOS
3	A05	2	367 450 573		TRANSPORTSCHUTZ		TOOL COVER	ENVELOPPE	TAPA PROTECTURA
3	A06	1	660 782 210		STECKSCHLÜSSEL	17	SOCKET WRENCH	CLÉ	LLAVE
3	A07	1	374 832 020		6KT-STIFTSCHLÜSS EL	4	HEX. WRENCH	CLÉ MÂLE COUDÉE	LLAVE HEXAGONAL
3	A08	1	367 783 217		6KT-STIFTSCHLÜSS EL	5	HEX. WRENCH	CLÉ MÂLE COUDÉE	LLAVE HEXAGONAL
3	A09	1	660 831 315	o. Abb.	ZUBEHÖRTASCHE		ACCESSORY BAG	POCHETTE D'ACCESSOIRES	BOLSO DE ACCESORIOS
3	A10	1	362 224 140		4-ZAHN-SCHLAGMES SER	230X1.8X25.4 - 4T	STAR BLADE	COUPEAU À 4 DENTS	CUCHILLA DE ACERO DE 4 DIE.
3	A10 A	1	660 195 139		BATTERIELADEGER ÄT	LG-363	BATTERY FAST CHARGER	CHARGEUR DE BATTERIES	CARGADOR DE BATERÍAS
3	A11	1	660 195 126		AKKU	AP-363 SET	BATTERY	BATTERIES	BATERÍAS
3	A12	1	660 451 153		KONTAKTSCHUTZKA PPE		BATTERY COVER	COUVERCLE BATTERIE	CUBIERTA BATERÍA

- 1** Hauptrohr, Griff, Schutzhaube, Getriebe  
 Pipe, handle, protector, bevel gear  
 Tube, poignée, capot de protection, engrenage  
 Tubo, mango, cubierta protectora, engranaje
- 2** Motor  
 Motor  
 Moteur  
 Motor
- 3** Zubehör  
 Accessories  
 Accessoires  
 Accesorios

	<b>Zeichenerklärung</b>	<b>Key to symbols</b>
<b>=&gt; 1999999</b> <b>2000000 =&gt;</b> <b>2003.04 =&gt;</b> <b>TI 2003/07</b> <b>Acc.</b> <b>=</b> <b>{</b> <b>m</b> <b>Corr.</b>	Produktion bis Serien-Nr. Neues Teil ab Serien-Nr. Neues Teil ab Jahr / Monat Siehe Technische Information Jahr / Nr. Zubehör (nicht im Lieferumfang) Keine Serienausführung, jedoch verwendbar Beinhaltet Positions-Nr. Meterware Druckfehlerberichtigung	Production to serial number New part from serial number New part from Year / Month See Technical Information Year / No. Accessories (not included in the delivery inventory) No standard execution, may be used Contains item number Sold by the meter Error correction
	Änderungen vorbehalten	Specifications subject to change without notice
	<b>Légende</b>	<b>Explicación de símbolos</b>
<b>=&gt; 1999999</b> <b>2000000 =&gt;</b> <b>2003.04 =&gt;</b> <b>TI 2003/07</b> <b>Acc.</b> <b>=</b> <b>{</b> <b>m</b> <b>Corr.</b>	Production jusqu'à n° de série Nouveau pièce à partir du n° de série Nouveau pièce à partir de année / mois Voir information technique année / n° Accessoires (non compris dans la livraison) Aucune exécut. en série, cependant utilisable contient n° de numéro Au mètre Rectification d'erreurs	Producción hasta N° de serie Pieza nueva a partir de N° de serie Pieza nueva a partir de año / mes Véase inform. técnico año / N° Accesorios (no incluido en la extensión del suministro) No es de serie, pero sirve Contiene pos N° Por metro Fe de erratas
	Changements sans préavis	Mejoras constructivas sin previo aviso