

Spare Parts List
Ersatzteilliste
Liste de pièces détachées
Lista de piezas de repuesto

2010-01

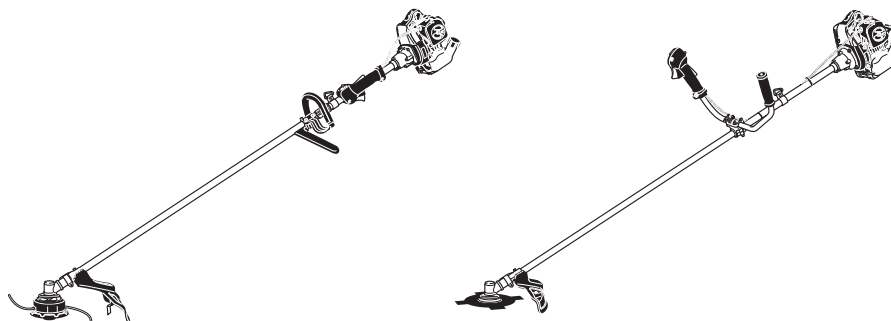

MS-230 C
MS-230 C (USA)
MS-260 C
MS-260 C (USA)
MS-260 U
MS-260 U (USA)

DOLMAR



A member of the *Makita* Group

995700190 (D, GB, F, E)

MS-230 C, MS-230 C ,
MS-260 C, MS-260 C , MS-260
U, MS-260 U

1

Kurbelgehäuse
Crankcase
Carter-vilebrequin
Carter cigüeñal

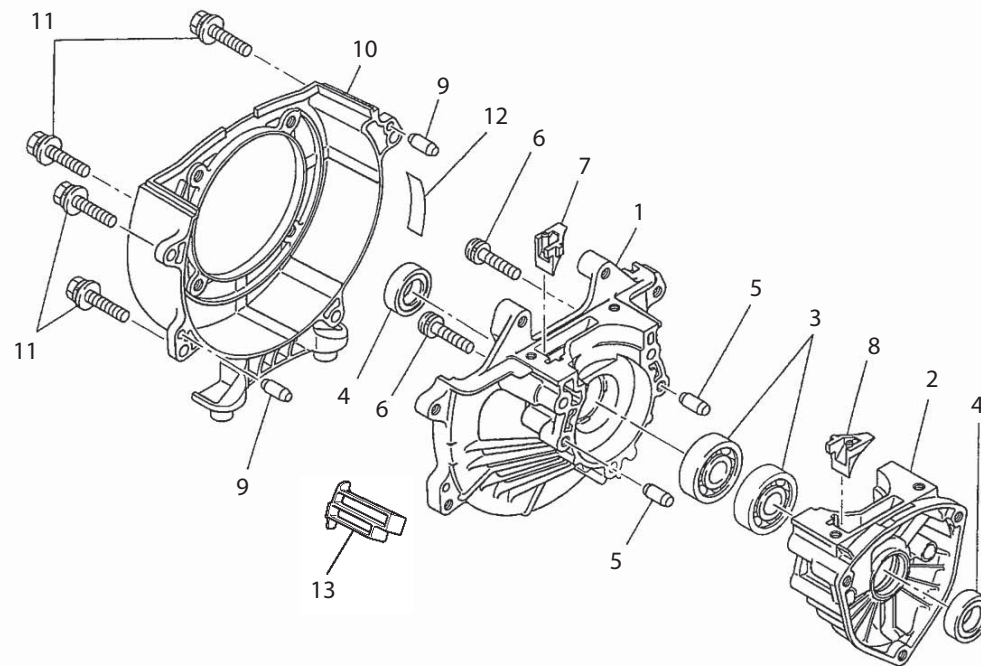

MS-230 C, MS-230 C ,
MS-260 C, MS-260 C , MS-260
U, MS-260 U

1

Kurbelgehäuse
Crankcase
Carter-vilebrequin
Carter cigüeñal

DOLMAR
A member of the **Takita** Group

Seite / Page	Pos.	MS-230 C	MS-230 C (USA)	MS-260 C	MS-260 C (USA)	MS-260 U	MS-260 U (USA)	Teil-Nr. Part No. No. de pièce No. de pieza	Hinweise Notes Renseign. Nota	Bezeichnung	Spezifikation Specification	Description	Désignation	Denominación
1	1	1	1	1	1	1	1	351 130 040		KURBELGEHÄUSE MS		CRANKCASE MS	CARTER-VILEBREQUIN MS	CARTER DEL CIGÜEÑAL MS
1	2	1	1	1	1	1	1	351 130 050		KURBELGEHÄUSE		CRANKCASE	CARTER-VILEBREQUIN	CARTER DEL CIGÜEÑAL
1	3	2	2	2	2	2	2	351 110 601		KUGELLAGER	6001	BALL BEARING	ROULEMENT À BILLES	RODAMIENTO DE BOLAS
1	4	2	2	2	2	2	2	351 210 050		RADIALDICHRING		RADIAL RING	JOINT RADIAL	JUNTA RADIAL
1	5	2	2	2	2	2	2	351 400 030		ZAPFEN		PIN	TOURILLON	PIVOTE
1	6	3	3	3	3	3	3	351 120 280		SCHRAUBE MIT SCHEIBE		SCREW & WASHER	VIS AVEC RONDELLE	TORNILLO CON ARANDELA
1	7	1	1	1	1	1	1	351 900 050		FÜHRUNG		GUIDE	GUIDAGE	GUÍA
1	8	1	1	1	1	1	1	351 900 060		FÜHRUNG		GUIDE	GUIDAGE	GUÍA
1	9	2	2	2	2	2	2	351 400 040		ZAPFEN		PIN	TOURILLON	PIVOTE
1	10	1	1	1	1	1	1	351 300 240		GEHÄUSE, POLRAD		FLYWHEEL HOUSING	CARTER ROUE POLAIRE	CARTER VOLANTE ENCEND.
1	11	4	4	4	4	4	4	352 645 690		6KT-SCHRAUBE MIT SCHEIBE		HEX. SCREW & WASHER	VIS HEX. AVEC RONDELLE	TORNILLO HEX. CON ARANDELA
1	12	1	1	1	1	1	1	351 560 560		SCHILD		LABEL	PLAQUE	CALCOMANÍA
1	13	1		1		1		351 900 760		KONTAKTSCHUTZ		CONTACT PROTECTION	PROTECTION DE CONTACT	PROTECTOR DEL CONTACTO

MS-230 C, MS-230 C ,
MS-260 C, MS-260 C , MS-260
U, MS-260 U

2

Zylinder, Abdeckhaube
Cylinder, top cover
Cylindre, coquille
Cilindro, cubierta

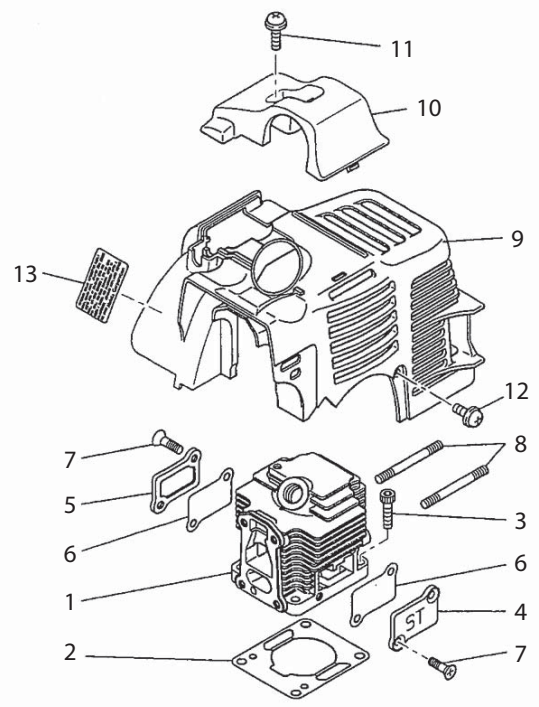

MS-230 C, MS-230 C ,
MS-260 C, MS-260 C , MS-260
U, MS-260 U

2

Zylinder, Abdeckhaube
Cylinder, top cover
Cylindre, coquille
Cilindro, cubierta

DOLMAR
A member of the **Takita** Group

Seite / Page	Pos.	MS-230 C	MS-230 C (USA)	MS-260 C	MS-260 C (USA)	MS-260 U	MS-260 U (USA)	Teil-Nr. Part No. No. de pièce No. de pieza	Hinweise Notes Renseign. Nota	Bezeichnung	Spezifikation Specification	Description	Désignation	Denominación
2	1	1	1					351 130 210		ZYLINDER		CYLINDER	CYLINDRE	CILINDRO
2	1			1	1	1	1	351 130 200		ZYLINDER		CYLINDER	CYLINDRE	CILINDRO
2	2	1	1	1	1	1	1	351 320 140		ZYLINDERDICHTUNG		CYLINDER GASKET	JOINT DE CYLINDRE	JUNTA DEL CILINDRO
2	3	4	4	4	4	4	4	351 121 052		SCHRAUBE		SCREW	VIS	TORNILLO
2	4	1	1	1	1	1	1	351 900 160		ABDECKUNG		COVER	COUVERCLE	TAPA
2	5	1	1	1	1	1	1	351 900 170		ZWISCHENFLANSCH		INTERMEDIATE FLANGE	BRIDE INTERMÉDIAIRE	BRIDA INTERMEDIA
2	6	2	2		2			351 390 770		DICHTUNG		GASKET	JOINT	JUNTA
2	6			2		2	2	351 390 790		DICHTUNG		GASKET	JOINT	JUNTA
2	7	4	4	4	4	4	4	351 120 310		SCHRAUBE	CTSK-CRS	SCREW	VIS	TORNILLO
2	8	2	2	2	2	2	2	351 151 055		BOLT		THREADED BOLT	BOULON FILETÉ	ESPIGA ROSCADA
2	9	1	1	1	1	1	1	352 400 940		HAUBE		COVER	COQUILLE	CUBIERTA
2	10	1	1	1	1	1	1	351 700 200		KERZENABDECKUNG		COVER FOR SPARK PLUG	COUVERCLE P. BOUGIE	TAPA P. BUJÍA
2	11	1	1	1	1	1	1	351 071 520		SCHRAUBE MIT SCHEIBE		SCREW & WASHER	VIS AVEC RONDELLE	TORNILLO CON ARANDELA
2	12	1	1	1	1	1	1	351 120 430		SCHRAUBE MIT SCHEIBE		SCREW & WASHER	VIS AVEC RONDELLE	TORNILLO CON ARANDELA
2	13	1		1		1		351 562 510		SCHILD, EMISSION		LABEL, EMISSION	PLAQUE "ÉMISSION"	CALCOMANÍA 'EMISIÓN'
2	13		1					351 562 490		SCHILD		LABEL, EMISSION	PLAQUE "ÉMISSION"	CALCOMANÍA 'EMISIÓN'
2	13				1		1	352 562 490		SCHILD		LABEL, EMISSION	PLAQUE "ÉMISSION"	CALCOMANÍA 'EMISIÓN'

MS-230 C, MS-230 C ,
MS-260 C, MS-260 C , MS-260
U, MS-260 U

3

Kurbelwelle, Kolben
Crankshaft, piston
Vilebrequin, piston
Cigüeñal, pistón

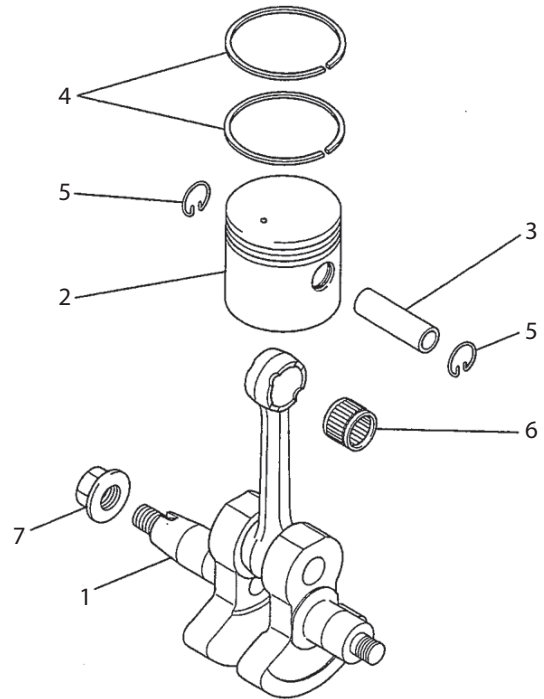

MS-230 C, MS-230 C ,
MS-260 C, MS-260 C , MS-260
U, MS-260 U

3

Kurbelwelle, Kolben
Crankshaft, piston
Vilebrequin, piston
Cigüeñal, pistón

DOLMAR



A member of the **Takita** Group

Seite / Page	Pos.	MS-230 C	MS-230 C (USA)	MS-260 C	MS-260 C (USA)	MS-260 U	MS-260 U (USA)	Teil-Nr. Part No. No. de pièce No. de pieza	Hinweise Notes Renseign. Nota	Bezeichnung	Spezifikation Specification	Description	Désignation	Denominación
3	1	1	1	1	1	1	1	351 010 330		KURBELWELLE KPL.		CRANKSHAFT ASSY.	VILE BREQUIN, COMPL.	CIGÜEÑAL, COMPL.
3	2	1	1					351 130 150		KOLBEN		PISTON	PISTON	PISTÓN
3	2			1	1	1	1	351 130 140		KOLBEN		PISTON	PISTON	PISTÓN
3	3	1	1					351 648 150		KOLBENBOLZEN		PISTON PIN	AXE DE PISTON	PERNO DE PISTÓN
3	3			1	1	1	1	351 510 080		KOLBENBOLZEN		PISTON PIN	AXE DE PISTON	PERNO DE PISTÓN
3	4	2	2					351 642 640		KOLBENRING		PISTON RING	SEGMENT DE PISTON	ANILLO DE PISTÓN
3	4			2	2	2	2	351 230 020		KOLBENRING		PISTON RING	SEGMENT DE PISTON	ANILLO DE PISTÓN
3	5	2	2	2	2	2	2	351 648 170		SPRENGRING		RETAINING RING	JONC	ANILLO DE SUJECIÓN
3	6	1	1	1	1	1	1	351 648 570		NADELLAGER		NEEDLE ROLLER BEARING	ROULEMENT À AIGUILLES	COJINETE DE AGUJAS
3	7	1	1	1	1	1	1	351 700 280		MUTTER	Conical SPG	NUT	ÉCROU	TUERCA

MS-230 C, MS-230 C ,
MS-260 C, MS-260 C , MS-260
U, MS-260 U

4

Polrad, Zünder
Flywheel, ignition coil
Roue polaire, bobine d'allum.
Volante encend., bobina encend.

DOLMAR



A member of the **Trakita** Group

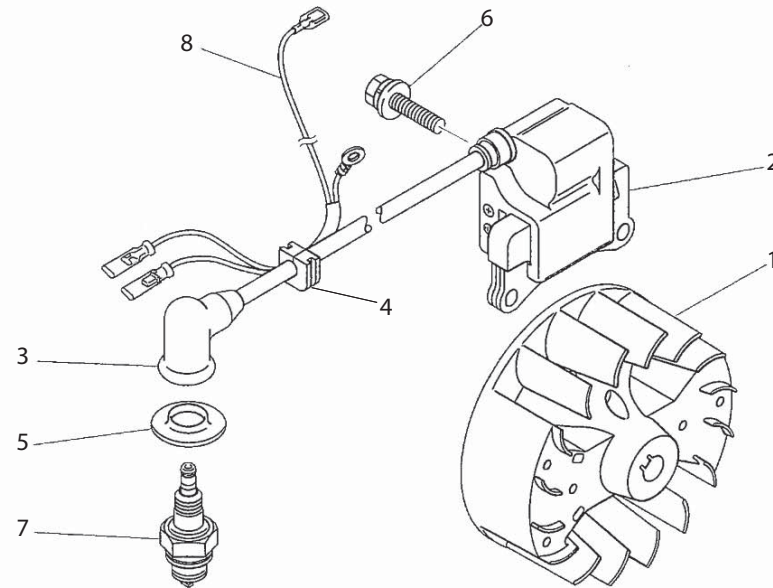

MS-230 C, MS-230 C ,
MS-260 C, MS-260 C , MS-260
U, MS-260 U

4

Polrad, Zünder
Flywheel, ignition coil
Roue polaire, bobine d'allum.
Volante encend., bobina encend.

DOLMAR



A member of the **Takita** Group

Seite / Page	Pos.	MS-230 C	MS-230 C (USA)	MS-260 C	MS-260 C (USA)	MS-260 U	MS-260 U (USA)	Teil-Nr. Part No. No. de pièce No. de pieza	Hinweise Notes Renseign. Nota	Bezeichnung	Spezifikation Specification	Description	Désignation	Denominación
4	1	1	1	1	1	1	1	351 110 260		POLRAD		FLYWHEEL	ROUE POLAIRE	VOLANTE ENCEND.
4	2	1	1	1	1	1	1	351 040 320		ZÜNDANKER	Incl.no.3	IGNITION COIL	BOBINE D'ALLUM.	BOBINA ENCEND.
4	3	1	1	1	1	1	1	351 649 610		KERZENSTECKER		PLUG CAP	FICHE DE BOUGIE	TAPA BUJÍA
4	4	1	1	1	1	1	1	351 900 010		GUMMITÜLLE		RUBBER BUSH	GAINE CAOUTCHOUC	BOQUILLA CAUCHO
4	5	1	1	1	1	1	1	351 667 510		KAPPE		CAP	CAPOT	CAPERUZA
4	6	2	2	2	2	2	2	351 645 690		6KT-SCHRAUBE MIT SCHEIBE		HEX. SCREW & WASHER	VIS HEX. AVEC RONDELLE	TORNILLO HEX. CON ARANDELA
4	7	1	1	1	1	1	1	351 410 110		ZÜNDKERZE	NGK BPMR8Y	SPARK PLUG	BOUGIE	BUJÍA
4	8	1	1	1	1	1	1	351 902 390		KABEL KPL.		CABLE ASSY.	CÂBLE COMPL.	CABLE COMPL.

MS-230 C, MS-230 C ,
MS-260 C, MS-260 C , MS-260
U, MS-260 U

5

Vergaser
Carburetor
Carburateur
Carburador

DOLMAR
A member of the *Takita* Group

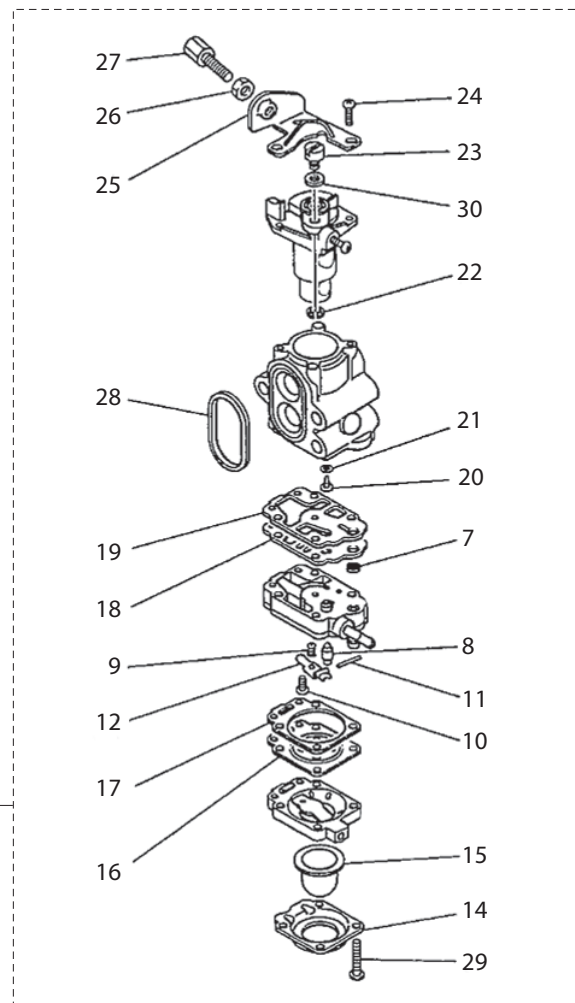
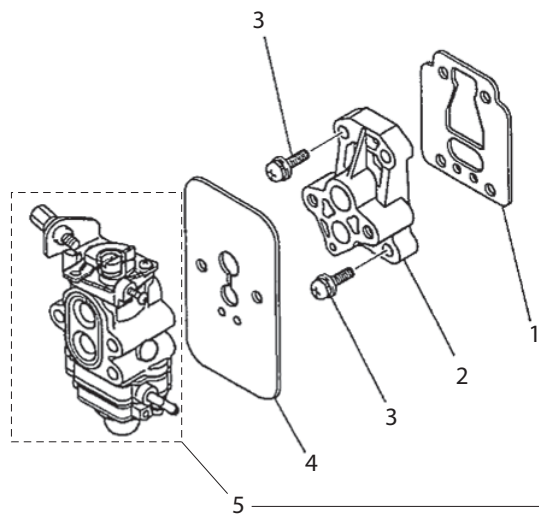

MS-230 C, MS-230 C ,
MS-260 C, MS-260 C , MS-260
U, MS-260 U

5

Vergaser
Carburetor
Carburateur
Carburador

DOLMAR
A member of the **Takita** Group

Seite / Page	Pos.	MS-230 C	MS-230 C (USA)	MS-260 C	MS-260 C (USA)	MS-260 U	MS-260 U (USA)	Teil-Nr. Part No. No. de pièce No. de pieza	Hinweise Notes Renseign. Nota	Bezeichnung	Spezifikation Specification	Description	Désignation	Denominación
5	1	1	1	1	1	1	1	351 340 660		ZWISCHENFLANSCHDICHTUNG		INTERMEDIATE FLANGE GASKET	JOINT BRIDE INTERMÉDIAIRE	JUNTA DE LA BRIDA INTERMEDIA
5	2	1	1	1	1	1	1	351 310 310		ZWISCHENFLANSCH		INTERMEDIATE FLANGE	BRIDE INTERMÉDIAIRE	BRIDA INTERMEDIA
5	3	4	4	4	4	4	4	352 649 600		SCHRAUBE MIT SCHEIBE		SCREW & WASHER	VIS AVEC RONDELLE	TORNILLO CON ARANDELA
5	4	1	1	1	1	1	1	351 390 910		VERGASERDICHTUNG		CARBURETOR GASKET	JOINT CARBURATEUR	JUNTA CARBURADOR
5	5	1	1					351 210 440		VERGASER	Incl.no.6-30	CARBURETOR	CARBURATEUR	CARBURADOR
5	5			1	1	1	1	352 210 520	2005.12 =>	VERGASER	Incl.no.6-30	CARBURETOR	CARBURATEUR	CARBURADOR
5	5			1	1	1	1	351 210 450	=> 2005.11	VERGASER	Incl.no.6-30	CARBURETOR	CARBURATEUR	CARBURADOR
5	7	1	1	1	1	1	1	351 210 092		SIEB		SCREEN	TAMIS	TAMIZ
5	8	1	1	1	1	1	1	351 220 073		EINLASSNADEL		INLET VALVE	POINTEAU D'ARRIVÉE	VÁLVULA DE ADMISIÓN
5	9	1	1	1	1	1	1	352 230 025		FEDER		SPRING	RESSORT	RESORTE
5	10	1	1	1	1	1	1	351 220 075		SCHRAUBE		SCREW	VIS	TORNILLO
5	11	1	1	1	1	1	1	353 666 527		ACHSE		AXLE	AXE	EJE
5	12	1	1	1	1	1	1	353 666 529		STEUERHEBEL		CONTROL LEVER	LEVIER DE COMMANDE	PALANCA DE MANDO
5	14	1	1	1	1	1	1	351 220 077		PUMPENDECKEL		PUMP COVER	COUVERCLE DE POMPE	TAPA DE BOMBA
5	15	1	1	1	1	1	1	351 210 173		KRAFTSTOFFPUMPE "PRIMER"		PRIMER FUEL PUMP	POMPE À CARBURANT (PRIMER)	BOMBA DE COMBUSTIBLE
5	16	1	1	1	1	1	1	351 210 286		MEMBRAN		DIAPHRAGM	MEMBRANE	MEMBRANA
5	17	1	1	1	1	1	1	352 220 072		DICHTUNG		GASKET	JOINT	JUNTA
5	18	1	1	1	1	1	1	352 210 175		MEMBRAN		DIAPHRAGM	MEMBRANE	MEMBRANA
5	19	1	1	1	1	1	1	352 210 289		DICHTUNG		GASKET	JOINT	JUNTA
5	20	1	1					352 220 570		DÜSE		JET	TUYÈRE	TOBERA
5	20			1	1	1	1	351 210 520	2005.12 =>	DÜSE		JET	TUYÈRE	TOBERA
5	20			1	1	1	1	352 210 300	=> 2005.11	DÜSE		JET	TUYÈRE	TOBERA
5	21	1	1	1	1	1	1	351 210 172		O-RING		O-RING	JOINT TORIQUE	ANILLO OBTURADOR
5	22	1	1	1	1	1	1	354 666 522		SICHERUNGSSCHEIBE		SAFETY WASHER	RONDELLE D'ARRÊT	ARANDELA DE SEGURIDAD
5	23	1	1	1	1	1	1	353 210 242		AUFNAHME FÜR BOWDENZUG		BOWDEN CABLE HOLDER	PORTE-CÂBLE BOWDEN	RECEPCIÓN DEL CABLE BOWDEN
5	24	2	2	2	2	2	2	353 210 171		SCHRAUBE		SCREW	VIS	TORNILLO
5	25	1	1	1	1	1	1	352 220 234		HALTERUNG		BRACKET	DISPOSITIF DE FIXATION	MONTURA
5	26	1	1	1	1	1	1	353 210 177		MUTTER		NUT	ÉCROU	TUERCA
5	27	1	1	1	1	1	1	352 220 086		EINSTELLSCHRAUBE		ADJUSTING SCREW	VIS D'AJUSTAGE	PERNO DE AJUSTE
5	28	1	1	1	1	1	1	353 210 289		DICHTRING		SEALING RING	BAGUE D'ÉTANCHÉITÉ	ANILLO DE JUNTA
5	29	4	4	4	4	4	4	352 220 079		SCHRAUBE		SCREW	VIS	TORNILLO
5	30	1	1	1	1	1	1	353 220 044		SCHEIBE		WASHER	RONDELLE	ARANDELA

MS-230 C, MS-230 C ,
MS-260 C, MS-260 C , MS-260
U, MS-260 U

6

Luftfilter
Air cleaner
Filtre à air
Filtro de aire

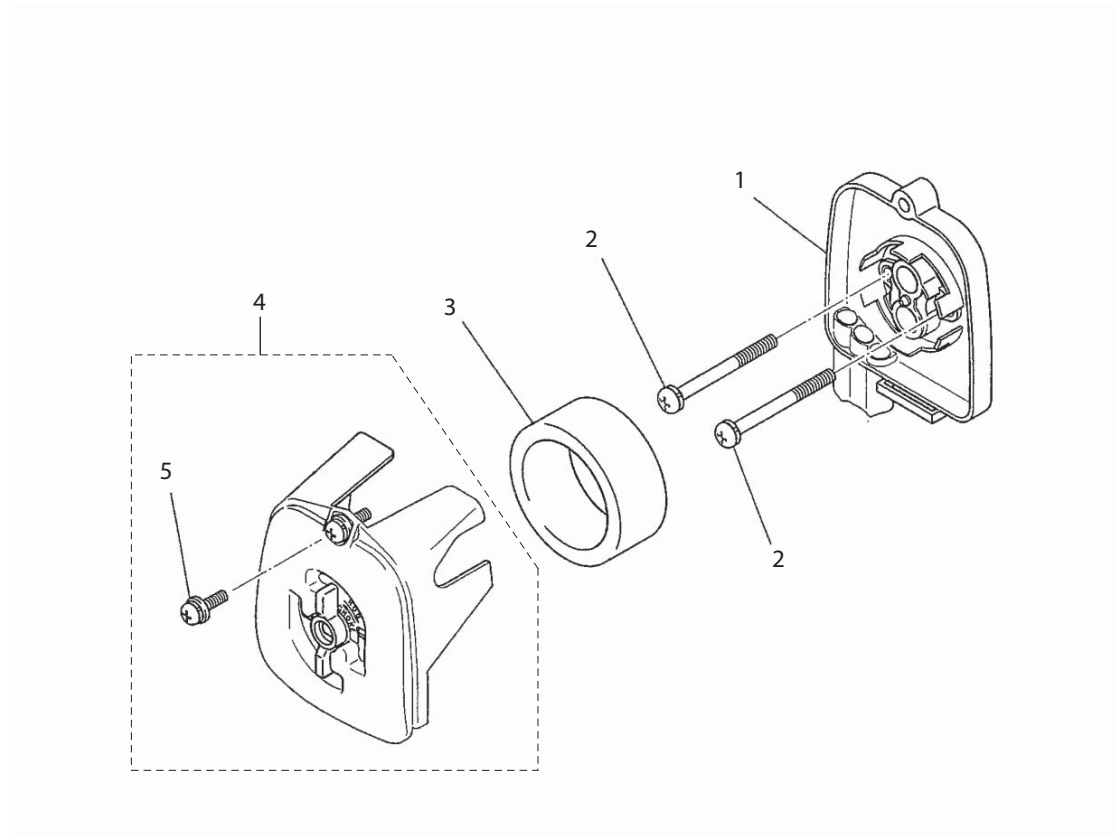

MS-230 C, MS-230 C ,
MS-260 C, MS-260 C , MS-260
U, MS-260 U

6

Luftfilter
Air cleaner
Filtre à air
Filtro de aire

DOLMAR



A member of the **Takita** Group

Seite / Page	Pos.	MS-230 C	MS-230 C (USA)	MS-260 C	MS-260 C (USA)	MS-260 U	MS-260 U (USA)	Teil-Nr. Part No. No. de pièce No. de pieza	Hinweise Notes Renseign. Nota	Bezeichnung	Spezifikation Specification	Description	Désignation	Denominación
6	1	1	1	1	1	1	1	351 110 250		LUFTFILTERAUFNAHME		AIR FILTER HOLDER	SUPPORT POUR FILTRE À AIR	SOPORTE DEL FILTRO DE AIRE
6	2	2	2	2	2	2	2	351 071 550		SCHRAUBE MIT SCHEIBE		SCREW & WASHER	VIS AVEC RONDELLE	TORNILLO CON ARANDELA
6	3	1	1	1	1	1	1	351 400 800		LUFTFILTER		AIR FILTER	FILTRE À AIR	FILTRO DE AIRE
6	4	1	1	1	1	1	1	351 020 320		LUFTFILTERDECKEL	Incl.no.5	AIR FILTER LID	COUVERCLE DE FILTRE À AIR	TAPA DEL FILTRO DE AIRE
6	5	1	1	1	1	1	1	351 649 600		SCHRAUBE MIT SCHEIBE		SCREW & WASHER	VIS AVEC RONDELLE	TORNILLO CON ARANDELA

MS-230 C, MS-230 C ,
MS-260 C, MS-260 C , MS-260
U, MS-260 U

7

Schalldämpfer
Muffler
Pot d' échappement
Silencioso

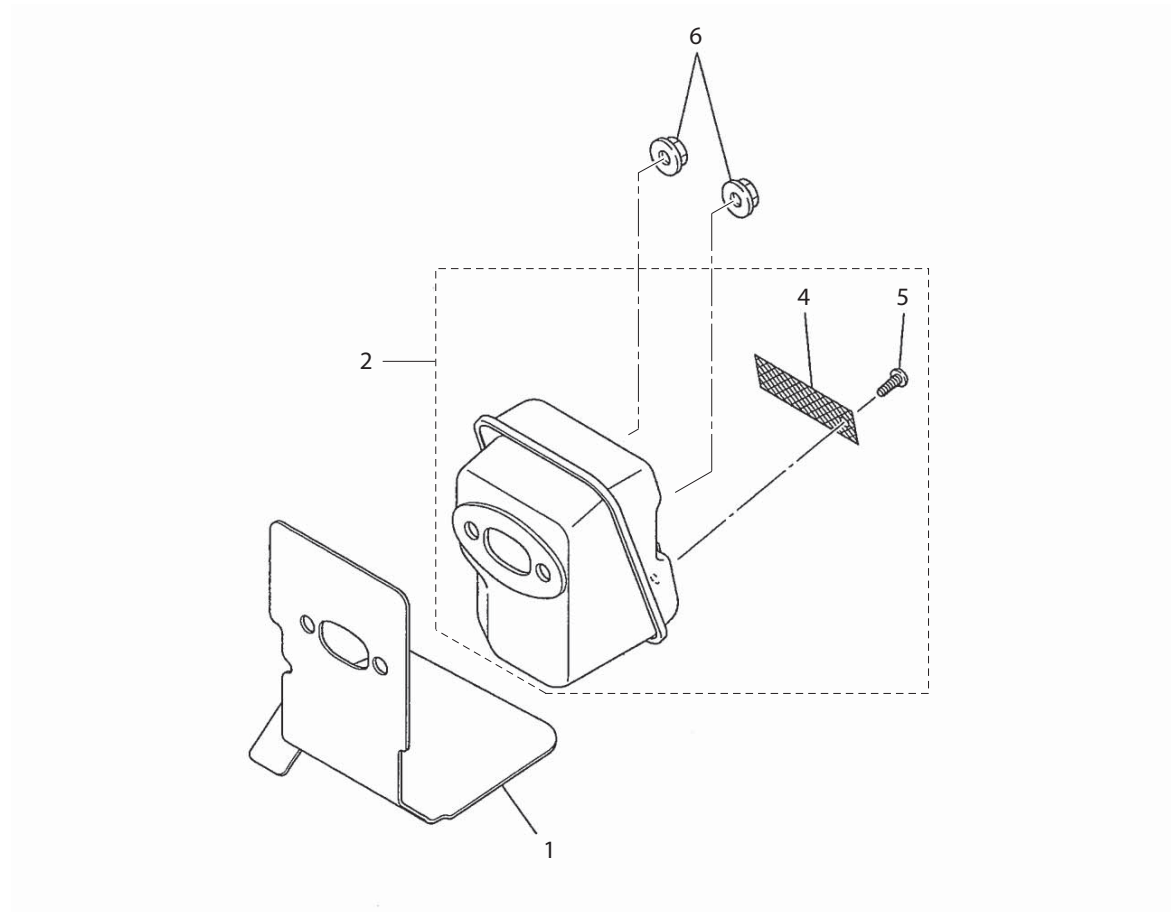

MS-230 C, MS-230 C ,
MS-260 C, MS-260 C , MS-260
U, MS-260 U

7

Schalldämpfer
Muffler
Pot d' échappement
Silencioso

DOLMAR



A member of the **Takita** Group

Seite / Page	Pos.	MS-230 C	MS-230 C (USA)	MS-260 C	MS-260 C (USA)	MS-260 U	MS-260 U (USA)	Teil-Nr. Part No. No. de pièce No. de pieza	Hinweise Notes Renseign. Nota	Bezeichnung	Spezifikation Specification	Description	Désignation	Denominación
7	1	1	1	1	1	1	1	351 700 610		DICHTUNG		GASKET	JOINT	JUNTA
7	2	1	1	1	1	1	1	351 010 801	2005.12 =>	SCHALLDÄMPFER KPL.	Incl.no.4-5	MUFFLER ASSY.	POT D'ÉCHAPPEMENT CPL.	SILENCIADOR CPL.
7	2	1	1	1	1	1	1	351 010 800	=> 2005.11	SCHALLDÄMPFER KPL.	Incl.no.4-5	MUFFLER ASSY.	POT D'ÉCHAPPEMENT CPL.	SILENCIADOR CPL.
7	4	1	1	1	1	1	1	352 901 890	2005.12 =>	FUNKENSCHUTZSIEB		SPARK ARRESTER SCREEN	TAMIS CONTRE ÉTINCELLES	TAMIZ PARACHISPAS
7	4	1	1	1	1	1	1	351 901 790	=> 2005.11	FUNKENSCHUTZSIEB		SPARK ARRESTER SCREEN	TAMIS CONTRE ÉTINCELLES	TAMIZ PARACHISPAS
7	5	1	1	1	1	1	1	351 006 306		SCHRAUBE		SCREW	VIS	TORNILLO
7	6	2	2	2	2	2	2	351 675 660		6KT-MUTTER		HEXAGONAL NUT	ÉCROU HEXAGONAL	TUERCA HEXAGONAL

MS-230 C, MS-230 C ,
MS-260 C, MS-260 C , MS-260
U, MS-260 U

8

Kupplung
Clutch
Embrayage
Embrague

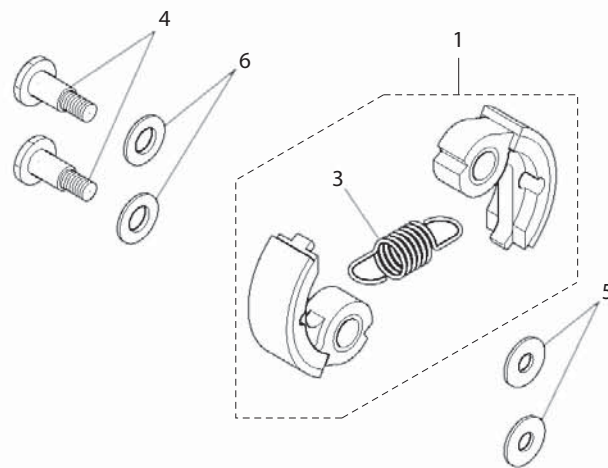

USA

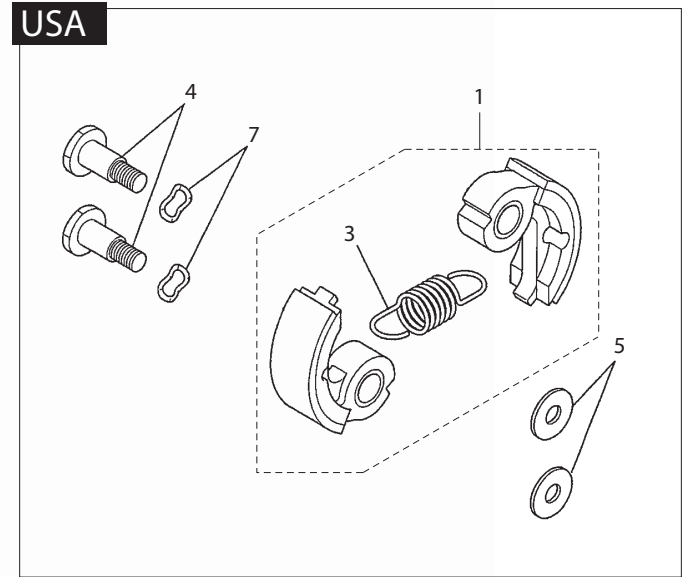

MS-230 C, MS-230 C ,
MS-260 C, MS-260 C , MS-260
U, MS-260 U

8

Kupplung
Clutch
Embrayage
Embrague

DOLMAR



A member of the **Takita** Group

Seite / Page	Pos.	MS-230 C	MS-230 C (USA)	MS-260 C	MS-260 C (USA)	MS-260 U	MS-260 U (USA)	Teil-Nr. Part No. No. de pièce No. de pieza	Hinweise Notes Renseign. Nota	Bezeichnung	Spezifikation Specification	Description	Désignation	Denominación
8	1	1		1		1		351 010 490		KUPPLUNG	Incl.no.3	CLUTCH	EMBAYAGE	EMBRAGUE
8	1		1		1		1	351 010 020		KUPPLUNG	Incl.no.3	CLUTCH	EMBAYAGE	EMBRAGUE
8	3	1		1		1		351 010 492		FEDER		SPRING	RESSORT	RESORTE
8	3		1		1		1	351 642 330		FEDER		SPRING	RESSORT	RESORTE
8	4	2		2		2		351 140 040		6KT-SCHRAUBE		HEX. SCREW	VIS HEX. AVEC RONDELLE	TORNILLO HEXAGONAL
8	4		2		2		2	351 140 030		SCHRAUBE		HEX. SCREW	VIS HEX. AVEC RONDELLE	TORNILLO HEXAGONAL
8	5	2		2		2		351 340 030		SCHEIBE		WASHER	RONDELLE	ARANDELA
8	5		2		2		2	352 673 470		SCHEIBE		WASHER	RONDELLE	ARANDELA
8	6	2		2		2		351 340 070		SCHEIBE		WASHER	RONDELLE	ARANDELA
8	7		2		2		2	351 360 010		SCHEIBE		WASHER	RONDELLE	ARANDELA

MS-230 C, MS-230 C ,
MS-260 C, MS-260 C , MS-260
U, MS-260 U

9

Starter
Starter
Dispositif de démarrage
Dispositivo de arranque

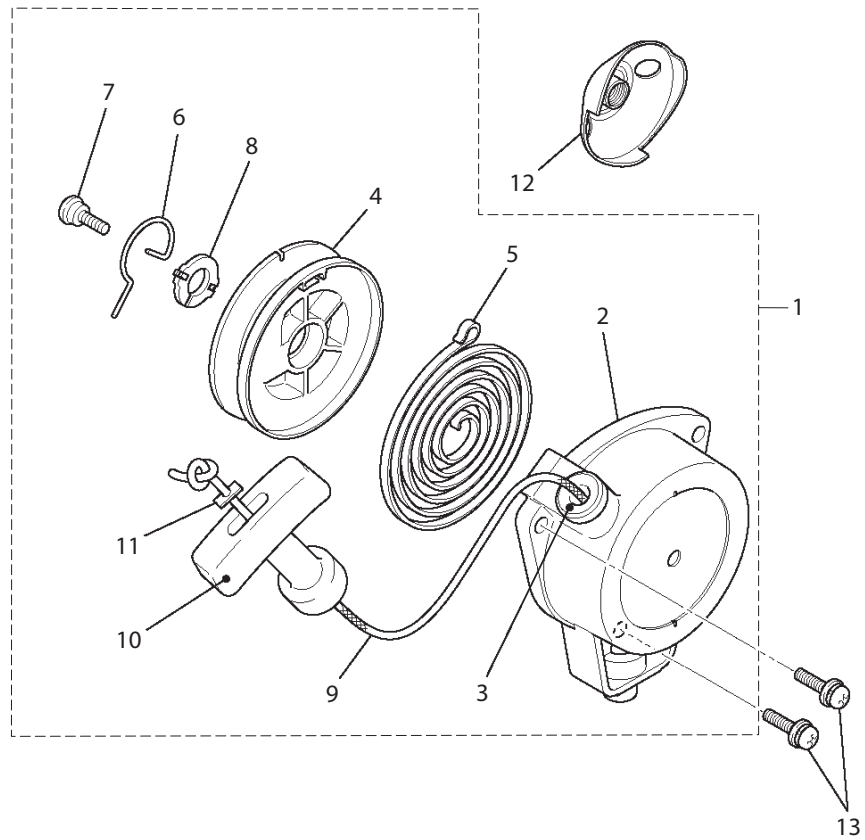

MS-230 C, MS-230 C ,
MS-260 C, MS-260 C , MS-260
U, MS-260 U

9

Starter
Starter
Dispositif de démarrage
Dispositivo de arranque

DOLMAR
A member of the **Takita** Group

Seite / Page	Pos.	MS-230 C	MS-230 C (USA)	MS-260 C	MS-260 C (USA)	MS-260 U	MS-260 U (USA)	Teil-Nr. Part No. No. de pièce No. de pieza	Hinweise Notes Renseign. Nota	Bezeichnung	Spezifikation Specification	Description	Désignation	Denominación
9	1	1	1	1	1	1	1	351 200 880		STARTER KPL.	Incl.no.2-11	STARTER ASSY.	LANCEUR COMPL.	ARRANQUE COMPL.
9	2	1	1	1	1	1	1	351 200 881		STARTERGEHÄUSE	Incl.no.3	STARTER HOUSING	CARTER LANCEUR	CAJA DE ARRANQUE
9	3	1	1	1	1	1	1	351 200 216		SEILFÜHRUNG		ROPE GUIDE	GUIDAGE DU CÂBLE	GUÍA DE CORDÓN
9	4	1	1	1	1	1	1	351 200 885		SEILTROMMEL		ROPE DRUM	TAMBOUR À CÂBLE	TAMBOR PARA CORDÓN
9	5	1	1	1	1	1	1	351 671 663		RÜCKHOLFEDER		REWIND SPRING	RESSORT RAPPEL	RESORTE RETENCIÓN
9	6	1	1	1	1	1	1	351 200 887		MITNEHMER		CATCH	TOC D'ENTRAÎNEMENT	ARRASTRE
9	7	1	1	1	1	1	1	351 200 888		SCHRAUBE		SCREW	VIS	TORNILLO
9	8	1	1	1	1	1	1	351 200 889		DISTANZSTÜCK		SPACER	PIÈCE DISTANCE	PIEZA DE SEPARACIÓN
9	9	1	1	1	1	1	1	352 200 881		ANWERFSEIL		STARTER ROPE	CÂBLE DÉMARRAGE	CORDÓN DE ARRANQUE
9	10	1	1	1	1	1	1	352 668 811		ANWERFGRIFF		STARTER GRIP	POIGNÉE DE LANCEMENT	TIRADOR DE ARRANQUE
9	11	1	1	1	1	1	1	352 200 970		SCHEIBE		WASHER	RONDELLE	ARANDELA
9	12	1	1	1	1	1	1	351 300 450		STARTERRAD		STARTER WHEEL	ROUE DÉCLENCHER	RUEDA DE ARRANQUE
9	13	2	2	2	2	2	2	351 120 430		SCHRAUBE MIT SCHEIBE		SCREW & WASHER	VIS AVEC RONDELLE	TORNILLO CON ARANDELA

MS-230 C, MS-230 C ,
MS-260 C, MS-260 C , MS-260
U, MS-260 U

10

Kraftstofftank
Fuel tank
Reservoir d'essence
Depósito de combustible

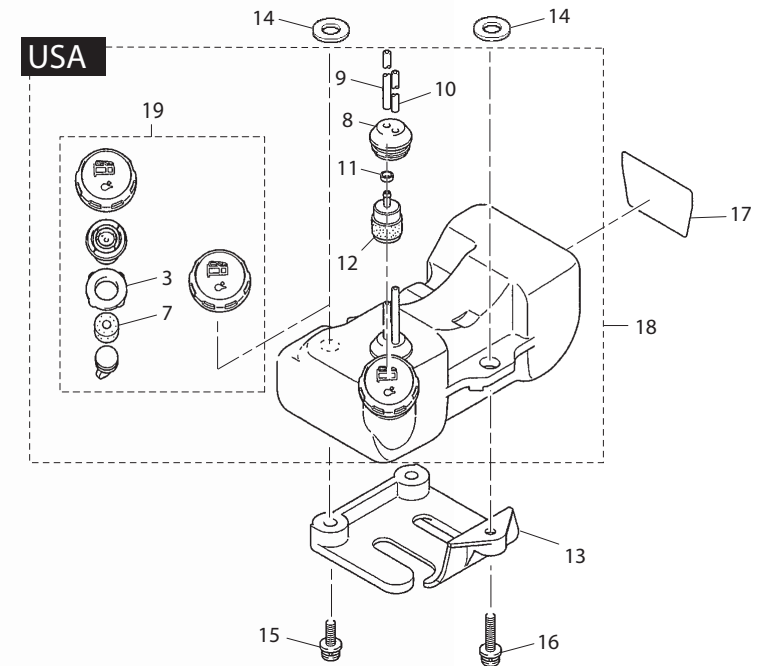
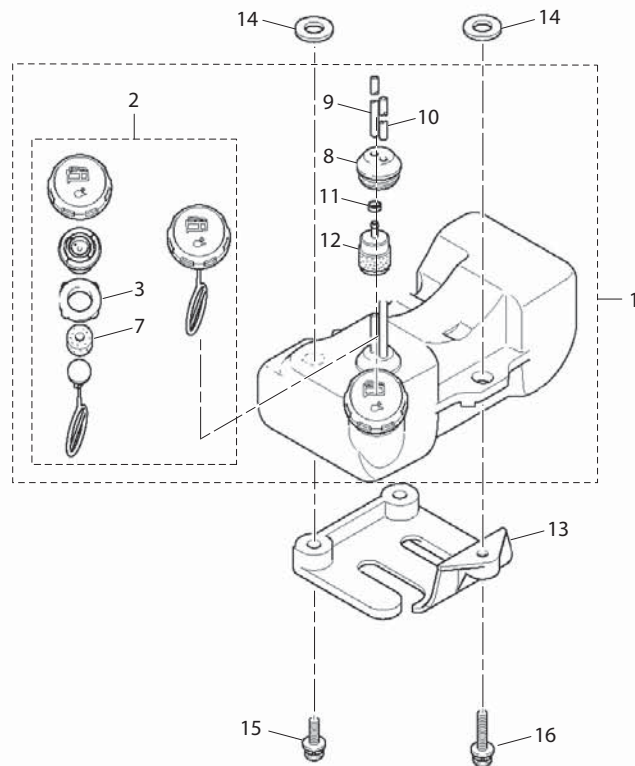

MS-230 C, MS-230 C ,
MS-260 C, MS-260 C , MS-260
U, MS-260 U

10

Kraftstofftank
Fuel tank
Reservoir d'essence
Depósito de combustible

DOLMAR
A member of the **Takita** Group

Seite / Page	Pos.	MS-230 C	MS-230 C (USA)	MS-260 C	MS-260 C (USA)	MS-260 U	MS-260 U (USA)	Teil-Nr. Part No. No. de pièce No. de pieza	Hinweise Notes Renseign. Nota	Bezeichnung	Spezifikation Specification	Description	Désignation	Denominación
10	1	1		1		1		351 010 750		KRAFTSTOFFTANK KPL.	Incl.no.2-12	FUEL TANK ASSY.	RÉSERVOIR D'ESSENCE COMPL.	DEPÓSITO DE COMBUSTIBLE COMPL.
10	2	1		1		1		351 050 230		TANKVERSCHLUß KPL.		TANK CAP	BOUCHON RÉSERVOIR	TAPA DEL DEPÓSITO
10	3	1	1	1	1	1	1	351 901 550		DICHTRING		SEALING RING	BAGUE D'ÉTANCHÉITÉ	ANILLO DE JUNTA
10	7	1	1	1	1	1	1	351 901 540		SCHAUMSTOFF		FOAMED MATERIAL	PRODUIT ALVÉOLAIRE	PLÁSTICO CELULAR
10	8	1	1	1	1	1	1	351 900 480		SCHLAUCHDURCHFÜHRUNG		HOSE FEEDTHROUGH	PASSAGE DE TUYAU	PASO DE TUBO
10	9	1	1	1	1	1	1	351 700 110		KRAFTSTOFFLEITUNG	L=220	FUEL HOSE	TUYAU ESSENCE	TUBO GASOLINA
10	10	1	1	1	1	1	1	351 700 310		KRAFTSTOFFLEITUNG	L=75	FUEL HOSE	TUYAU ESSENCE	TUBO GASOLINA
10	11	1	1	1	1	1	1	351 010 337		SCHLAUCHKLEMME		HOSE CLAMP	PINCE POUR TUYAUX	APRIETE DE TUBO
10	12	1	1	1	1	1	1	352 400 040		KRAFTSTOFFFILTER		FUEL FILTER	FILTRE ESSENCE	FILTRO GASOLINA
10	13	1	1	1	1	1	1	351 300 200		STANDFUß		BASE	BASE	BASE
10	14	3	3	3	3	3	3	351 800 080		PUFFER		BUFFER	BUTOIR	TOPE
10	15	2	2	2	2	2	2	352 120 180		SCHRAUBE MIT SCHEIBE		SCREW & WASHER	VIS AVEC RONDELLE	TORNILLO CON ARANDELA
10	16	1	1	1	1	1	1	354 120 180		SCHRAUBE MIT SCHEIBE		SCREW&WASHER	VIS AVEC RONDELLE	TORNILLO CON ARANDELA
10	17		1		1		1	351 561 810		SCHILD		LABEL	PLAQUE	CALCOMANÍA
10	18		1		1		1	352 010 750		TANK KPL.	Incl.no.8-12, 19	FUEL TANK ASSY.	RÉSERVOIR D'ESSENCE COMPL.	DEPÓSITO DE COMBUSTIBLE COMPL.
10	19		1		1		1	352 050 190		TANKDECKEL		TANK CAP	BOUCHON RÉSERVOIR	TAPA DEL DEPÓSITO

MS-230 C, MS-230 C ,
MS-260 C, MS-260 C , MS-260
U, MS-260 U

11

Werkzeug
Tools
Outils
Herramientas

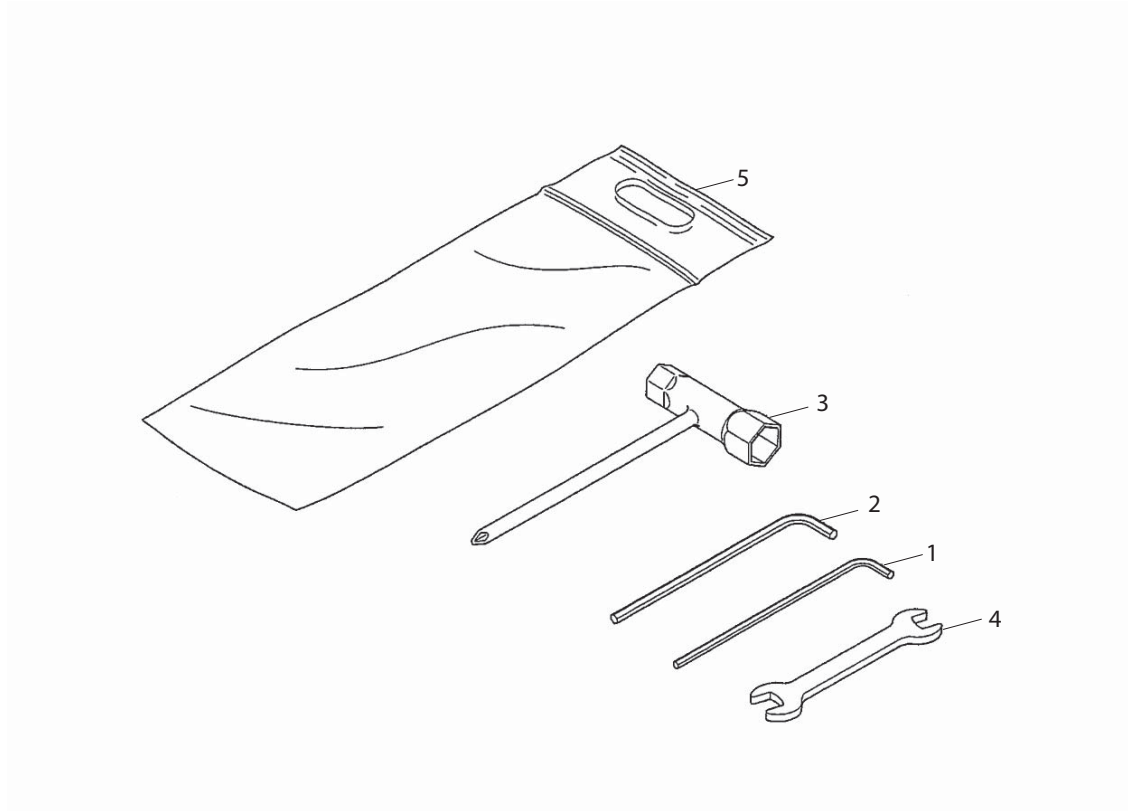

MS-230 C, MS-230 C ,
MS-260 C, MS-260 C , MS-260
U, MS-260 U

11

Werkzeug
Tools
Outils
Herramientas

DOLMAR



A member of the **Makita** Group

Seite / Page	Pos.	MS-230 C	MS-230 C (USA)	MS-260 C	MS-260 C (USA)	MS-260 U	MS-260 U (USA)	Teil-Nr. Part No. No. de pièce No. de pieza	Hinweise Notes Renseign. Nota	Bezeichnung	Spezifikation Specification	Description	Désignation	Denominación
11	1	1	1	1	1	1	1	351 010 151		6KT-STIFTSCHLÜSSEL		ALLEN KEY	CLÉ MÂLE COUDÉE	LLAVE HEXAGONAL
11	2	1	1	1	1	1	1	351 010 152		6KT-STIFTSCHLÜSSEL		ALLEN KEY	CLÉ MÂLE COUDÉE	LLAVE HEXAGONAL
11	3	1	1	1	1	1	1	351 010 153		KOMBISCHLÜSSEL		COMBI WRENCH	CLÉ COMBI	LLAVE COMBI
11	4	1	1	1	1	1	1	351 010 154		MAULSCHLÜSSEL		SPANNER	CLÉ PLATE	LLAVE DE BOCA
11	5	1	1	1	1	1	1	351 010 155		WERKZEUGTASCHE		TOOL-BAG	POCHETTE À OUTILS	BOLSA DE HERRAMIENTAS

MS-230 C, MS-230 C ,
MS-260 C, MS-260 C , MS-260
U, MS-260 U

12,1

C - Schaftrohr, Handgriff
C - Main pipe, handle
C - Tube principal, poignée
C - Tubo principal, mango

DOLMAR



A member of the **Takita** Group

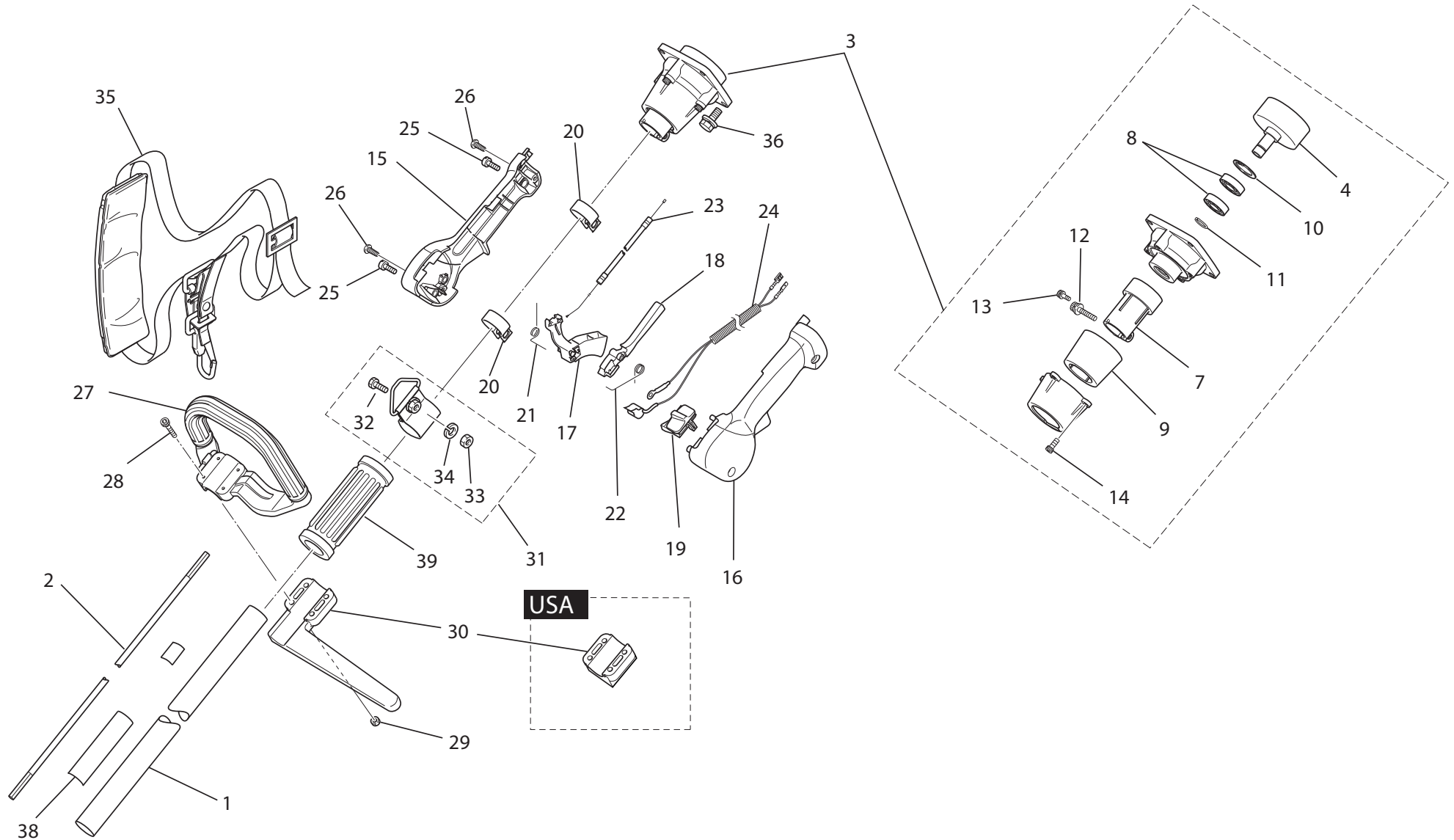

MS-230 C, MS-230 C ,
MS-260 C, MS-260 C , MS-260
U, MS-260 U

12,1

C - Schaftrohr, Handgriff
C - Main pipe, handle
C - Tube principal, poignée
C - Tubo principal, mango

DOLMAR
A member of the **Takita** Group

Seite / Page	Pos.	MS-230 C	MS-230 C (USA)	MS-260 C	MS-260 C (USA)	Teil-Nr. Part No. No. de pièce No. de pieza	Hinweise Notes Renseign. Nota	Bezeichnung	Spezifikation Specification	Description	Désignation	Denominación
12,1	1	1	1	1	1	351 501 091		SCHAFTROHR		MAIN PIPE	TUBE PRINCIPALE	TUBO PRINCIPAL
12,1	2	1	1	1	1	351 501 042		ANTRIEBSWELLE		DRIVE SHAFT	ARBRE MOTEUR	ÁRBOL MOTOR
12,1	3	1	1	1	1	351 505 080		KUPPLUNGSGEHÄUSE KPL.	Incl.no.5-15	CLUTCH CASE ASSY.	CARTER D'EMBRAYAGE CPL.	CARTER DE EMBRAGUE CPL.
12,1	4	1	1	1	1	351 505 041		KUPPLUNGSTROMMEL		CLUTCH DRUM	CLOCHE D'EMBRAYAGE	TAMBOR DE EMBRAGUE
12,1	7	1	1	1	1	351 505 044		KLEMMBUCHSE		BEARING SPACER	DOUILLE DE SERRAGE	CASQUILLO DE APRIETE
12,1	8	2	2	2	2	351 505 013		KUGELLAGER		BALL BEARING	ROULEMENT À BILLES	RODAMIENTO DE BOLAS
12,1	9	1	1	1	1	351 505 046		GUMMIDÄMPFER		VIBRATION DAMPER	AMORTISSEUR DE VIBRATIONS	AMORTIGUADOR DE VIBRACIONES
12,1	10	1	1	1	1	351 505 015		SICHERUNGSRING		CIRCLIP	CIRCLIP	ANILLO FIJADOR
12,1	11	1	1	1	1	351 505 016		SICHERUNGSRING		CIRCLIP	CIRCLIP	ANILLO FIJADOR
12,1	12	1	1	1	1	351 505 017		SCHRAUBE		SCREW	VIS	TORNILLO
12,1	13	1	1	1	1	351 505 018		SCHRAUBE		SCREW	VIS	TORNILLO
12,1	14	4	4	4	4	351 505 047		6KT-SCHRAUBE		SCREW	VIS	TORNILLO
12,1	15	1	1	1	1	351 506 021		GRIFFHÄLFTE RECHTS		LEVER CASE, RIGHT	DEMI-POIGNÉE DROIT	SEMI-MANGO DER.
12,1	16	1	1	1	1	351 506 023		GRIFFHÄLFTE		HANDLE HALF	POIGNÉE EXTÉRIEURE	PARTE DEL MANGO
12,1	17	1	1	1	1	351 506 025		GASHEBEL		THROTTLE LEVER	LEVIER DE GAZ	PALANCA DE GAS
12,1	18	1	1	1	1	351 506 026		SICHERUNGSHABEL		SAFETY LEVER	LEVIER DE SECURITÉ	PALANCA SEGURIDAD
12,1	19	1	1	1	1	351 506 027		KURZSCHLUßSCHALTER		SHORT-CIRCUIT SWITCH	INTERRUPTEUR COURT-CIRCUIT	INTERRUPTOR DE CORTOCICUITO
12,1	20	2	2	2	2	351 506 028		SHELLE		CLIP	PINCE	ABRAZADERA
12,1	21	1	1	1	1	351 506 019		DREHFEDER		TORSION SPRING	RESSORT DE TENSION	RESORTE DE TORSIÓN
12,1	22	1	1	1	1	352 506 010		FEDER		SPRING	RESSORT	RESORTE
12,1	23	1	1	1	1	352 506 011		BOWDENZUG		BOWDEN CABLE	CÂBLE BOWDEN	CABLE BOWDEN
12,1	24	1	1	1	1	352 506 013		KABEL KPL.		CABLE ASSY.	CÂBLE COMPL.	CABLE COMPL.
12,1	25	2	2	2	2	351 505 018		SCHRAUBE		SCREW	VIS	TORNILLO
12,1	26	4	4	4	4	352 506 015		SCHRAUBE		SCREW	VIS	TORNILLO
12,1	27	1		1		351 507 061		HANDGRIFF		HANDLE	POIGNÉE	MANGO
12,1	27		1		1	351 507 021		GRIFF		HANDLE	POIGNÉE	MANGO
12,1	28	4	4	4	4	351 507 014		SCHRAUBE		SCREW	VIS	TORNILLO
12,1	29	4	4	4	4	351 504 016		MUTTER		NUT	ÉCROU	TUERCA
12,1	30	1		1		351 507 026		KLEMMSCHALE FÜR HANDGRIFF		CLAMPING HOLDER FOR HANDLE	DISP. DE SERRAGE POUR POIGNÉE	SOPORTE PRESOR PARA MANGO
12,1	30		1		1	351 507 306		KAPPE		CLAMPING HOLDER FOR HANDLE	DISP. DE SERRAGE POUR POIGNÉE	SOPORTE PRESOR PARA MANGO
12,1	31	1		1		351 508 050		GURTAUFNAHME KPL.	Incl.no.33-35	HARNESS ATTACHMENT ASSY.	ATTACHE DE BRETTELLE COMPL.	SUJECIÓN COMPL.
12,1	31		1		1	351 508 030		GURTAUFNAHME KPL.	Incl.no.33-35	HARNESS ATTACHMENT ASSY.	ATTACHE DE BRETTELLE COMPL.	SUJECIÓN COMPL.
12,1	32	1	1	1	1	351 508 012		SCHRAUBE		SCREW	VIS	TORNILLO
12,1	33	1	1	1	1	351 508 013		MUTTER		NUT	ÉCROU	TUERCA
12,1	34	1	1	1	1	351 508 014		SCHLEIBE		WASHER	RONDELLE	ARANDELA
12,1	35	1	1	1	1	351 509 010		SCHULTERGURT		SHOULDER HARNESS	BRETTELLE	HARNESS
12,1	36	4	4	4	4	351 504 020		SCHRAUBE		SCREW	VIS	TORNILLO
12,1	38	1		1		351 501 093		SCHILD, BEDIENHINWEISE		LABEL, CAUTION	PLAQUE, DIRECTIVES DE COMMANDE	CALCOMANÍA, INDICACIONES DE MANEJO
12,1	39	1		1		351 501 095		HANDGRIFF		HANDLE	POIGNÉE	MANGO

MS-230 C, MS-230 C ,
MS-260 C, MS-260 C , MS-260
U, MS-260 U

12,2

U - Schaftrohr, Handgriff
U - Main pipe, handle
U - Tube principal, poignée
U - Tubo principal, mango

DOLMAR



A member of the **Takita** Group

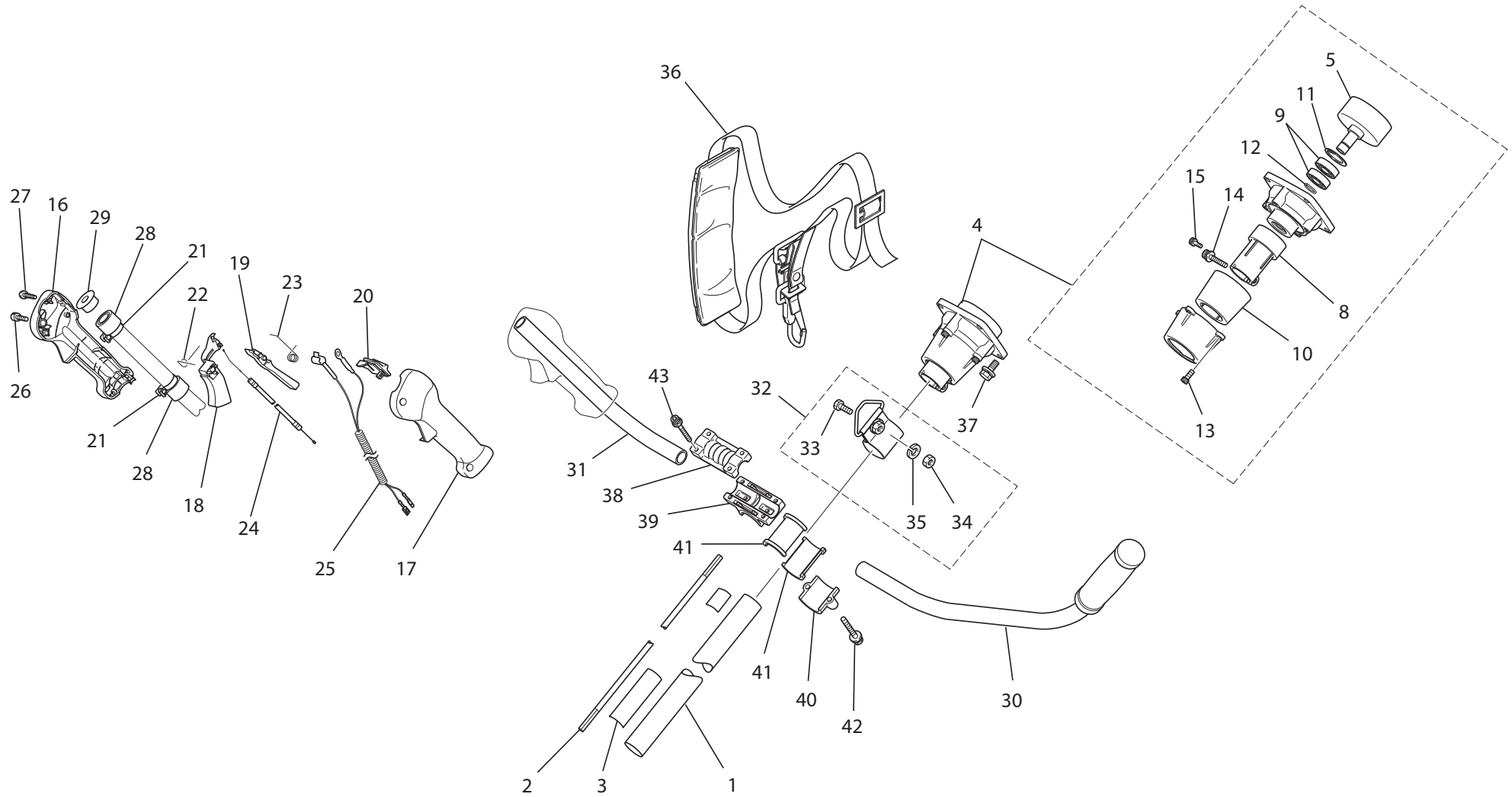

MS-230 C, MS-230 C ,
MS-260 C, MS-260 C , MS-260
U, MS-260 U

12,2

U - Schaftrohr, Handgriff
U - Main pipe, handle
U - Tube principal, poignée
U - Tubo principal, mango

DOLMAR
A member of the **Takita** Group

Seite / Page	Pos.	MS-260 U	MS-260 U (USA)	Teil-Nr. Part No. No. de pièce No. de pieza	Hinweise Notes Renseign. Nota	Bezeichnung	Spezifikation Specification	Description	Désignation	Denominación
12.2	1	1	1	351 501 091		SCHAFTROHR		MAIN PIPE	TUBE PRINCIPALE	TUBO PRINCIPAL
12.2	2	1	1	351 501 042		ANTRIEBSWELLE		DRIVE SHAFT	ARBRE MOTEUR	ÁRBOL MOTOR
12.2	3	1		351 501 093		SCHILD, BEDIENHINWEISE		LABEL, CAUTION	PLAQUE, DIRECTIVES DE COMMANDE	CALCOMANÍA, INDICACIONES DE MANEJO
12.2	3		1	351 501 014		SCHILD		LABEL, CAUTION	PLAQUE, DIRECTIVES DE COMMANDE	CALCOMANÍA, INDICACIONES DE MANEJO
12.2	4	1	1	351 505 080		KUPPLUNGSGEHÄUSE KPL.	Incl.no.5-15	CLUTCH CASE ASSY.	CARTER D'EMBRAYAGE CPL.	CARTER DE EMBRAGUE CPL.
12.2	5	1	1	351 505 041		KUPPLUNGSTROMMEL		CLUTCH DRUM	CLOCHE D'EMBRAYAGE	TAMBOR DE EMBRAGUE
12.2	8	1	1	351 505 044		KLEMMBUCHSE		BEARING SPACER	DOUILLE DE SERRAGE	CASQUILLO DE APRIETE
12.2	9	2	2	351 505 013		KUGELLAGER		BALL BEARING	ROULEMENT À BILLES	RODAMIENTO DE BOLAS
12.2	10	1	1	351 505 046		GUMMIDÄMPFER		VIBRATION DAMPER	AMORTISSEUR DE VIBRATIONS	AMORTIGUADOR DE VIBRACIONES
12.2	11	1	1	351 505 015		SICHERUNGSRING		CIRCLIP	CIRCLIP	ANILLO FIJADOR
12.2	12	1	1	351 505 016		SICHERUNGSRING		CIRCLIP	CIRCLIP	ANILLO FIJADOR
12.2	13	4	4	351 505 047		6KT-SCHRAUBE		SCREW	VIS	TORNILLO
12.2	14	1	1	351 505 017		SCHRAUBE		SCREW	VIS	TORNILLO
12.2	15	1	1	351 505 018		SCHRAUBE		SCREW	VIS	TORNILLO
12.2	16	1	1	351 506 021		GRIFFHÄLFTE RECHTS		LEVER CASE, RIGHT	DEMI-POIGNÉE DROIT	SEMI-MANGO DER.
12.2	17	1	1	351 506 023		GRIFFHÄLFTE		HANDLE HALF	POIGNÉE EXTÉRIEURE	PARTE DEL MANGO
12.2	18	1	1	351 506 025		GASHEBEL		THRITTLE LEVER	LEVIER DE GAZ	PALANCA DE GAS
12.2	19	1	1	351 506 026		SICHERUNGSHABEL		SAFETY LEVER	LEVIER DE SECURITÉ	PALANCA SEGURIDAD
12.2	20	1	1	351 506 027		KURZSCHLUßSCHALTER		SHORT-CIRCUIT SWITCH	INTERRUPTEUR COURT-CIRCUIT	INTERRUPTOR DE CORTOCIRCUITO
12.2	21	2		351 506 038		SHELLE		CLIP	PINCE	ABRAZADERA
12.2	21		2	351 506 028		SHELLE		CLIP	PINCE	ABRAZADERA
12.2	22	1	1	351 506 019		DREHFEDER		TORSION SPRING	RESSORT DE TENSION	RESORTE DE TORSIÓN
12.2	23	1	1	352 506 010		FEDER		SPRING	RESSORT	RESORTE
12.2	24	1	1	352 506 031		BOWDENZUG		BOWDEN CABLE	CÂBLE BOWDEN	CABLE BOWDEN
12.2	25	1	1	352 506 033		KABEL KPL.		CABLE ASSY.	CÂBLE COMPL.	CABLE COMPL.
12.2	26	1	1	351 505 018		SCHRAUBE		SCREW	VIS	TORNILLO
12.2	27	4	4	352 506 015		SCHRAUBE		SCREW	VIS	TORNILLO
12.2	28	2	2	352 506 036		GUMMIDÄMPFER		VIBRATION DAMPER	AMORTISSEUR DE VIBRATIONS	AMORTIGUADOR DE VIBRACIONES
12.2	29	1	1	352 506 037		ROHRENDSTOPFEN		TUBE END PLUG	TAMPON FINAL POUR TUBE	TAPÓN TERMINAL DE TUBO
12.2	30	1	1	351 507 073		GRIFFROHR LINKS		HANDLE LEFT	TUBE DE POIGNÉE GAUCHE	TUBO DE MANGO IZQUIERDO
12.2	31	1	1	352 507 072		GRIFFROHR RECHTS		HANDLE TUBE RIGHT	POIGNÉE DROITE	MANGO DERECHO
12.2	32	1		351 508 050		GURTAUFNAHME KPL.	Incl.no.33-35	HARNESS ATTACHMENT ASSY.	ATTACHE DE BRETTELLE COMPL.	SUJECIÓN COMPL.
12.2	32		1	351 508 030		GURTAUFNAHME KPL.	Incl.no.33-35	HARNESS ATTACHMENT ASSY.	ATTACHE DE BRETTELLE COMPL.	SUJECIÓN COMPL.
12.2	33	1	1	351 508 012		SCHRAUBE		SCREW	VIS	TORNILLO
12.2	34	1	1	351 508 013		MUTTER		NUT	ÉCROU	TUERCA
12.2	35	1	1	351 508 014		SCHEIBE		WASHER	RONDELLE	ARANDELA
12.2	36	1	1	351 509 010		SCHULTERGURT		SHOULDER HARNESS	BRETTELLE	HARNESS
12.2	37	4	4	351 504 020		SCHRAUBE		SCREW	VIS	TORNILLO
12.2	38	1	1	351 512 011		KLEMMSCHELE GRIFFROHR		CLAMPING HOLDER, HANDLE TUBE	DISP. DE SERRAGE POUR TUBE DE POIGNÉE	SOPORTE PRESOR, TUBO DE MANGO

MS-230 C, MS-230 C ,
MS-260 C, MS-260 C , MS-260
U, MS-260 U

12,2

U - Schaftrohr, Handgriff
U - Main pipe, handle
U - Tube principal, poignée
U - Tubo principal, mango

DOLMAR



A member of the **Takita** Group

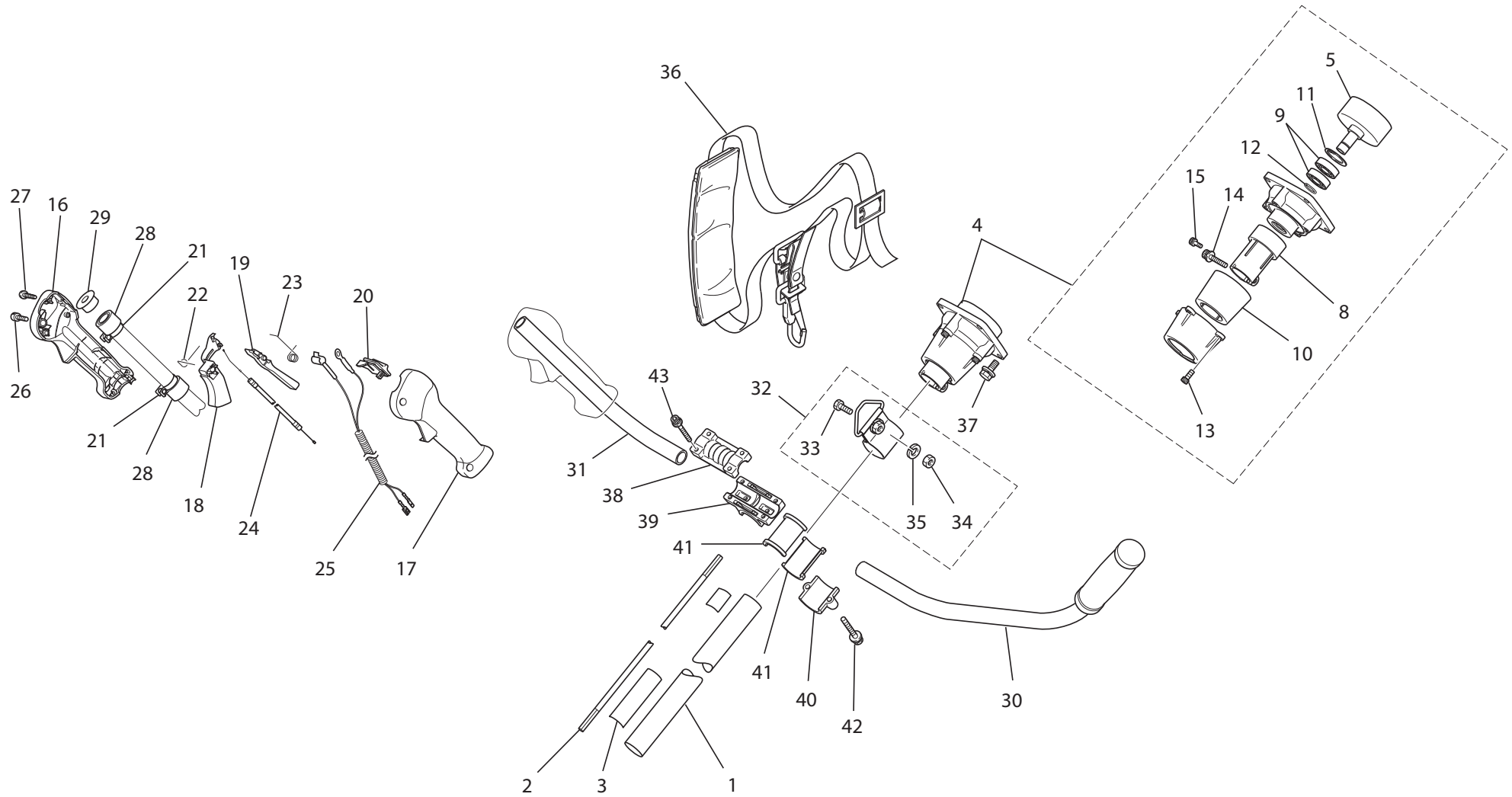

MS-230 C, MS-230 C ,
MS-260 C, MS-260 C , MS-260
U, MS-260 U

12,2

U - Schaftrohr, Handgriff
U - Main pipe, handle
U - Tube principal, poignée
U - Tubo principal, mango



Seite / Page	Pos.	MS-260 U	MS-260 U (USA)	Teil-Nr. Part No. No. de pièce No. de pieza	Hinweise Notes Renseign. Nota	Bezeichnung	Spezifikation Specification	Description	Désignation	Denominación
12.2	39	1	1	351 512 012		GRIFFHALTERUNG		HANDLE BRACKET	PORTE-POIGNÉE	MONTURA DE EMPUÑADURA
12.2	40	1	1	351 512 013		KLEMMSCHALE SCHAFTROHR		CLAMPING HOLDER, MAIN PIPE	DISP. DE SERRAGE POUR TUBE PRINCIPALE	SOPORTE PRESOR, TUBO PRINCIPAL
12.2	41	2	2	351 512 014		DÄMPFUNGSELEMENT		DAMPING ELEMENT	ÉLEMENT DE AMORTISSEUR	ELEMENTO AMORTIGUADOR
12.2	42	2	2	351 505 017		SCHRAUBE		SCREW	VIS	TORNILLO
12.2	43	4	4	351 505 047		6KT-SCHRAUBE		SCREW	VIS	TORNILLO

MS-230 C, MS-230 C ,
MS-260 C, MS-260 C , MS-260
U, MS-260 U

13

Getriebe, Schneidwerkzeug
Gear, cutting tools
Engrenage, Outils tranchants
Engranaje, Herramientas de corte

DOLMAR



A member of the **Takita** Group

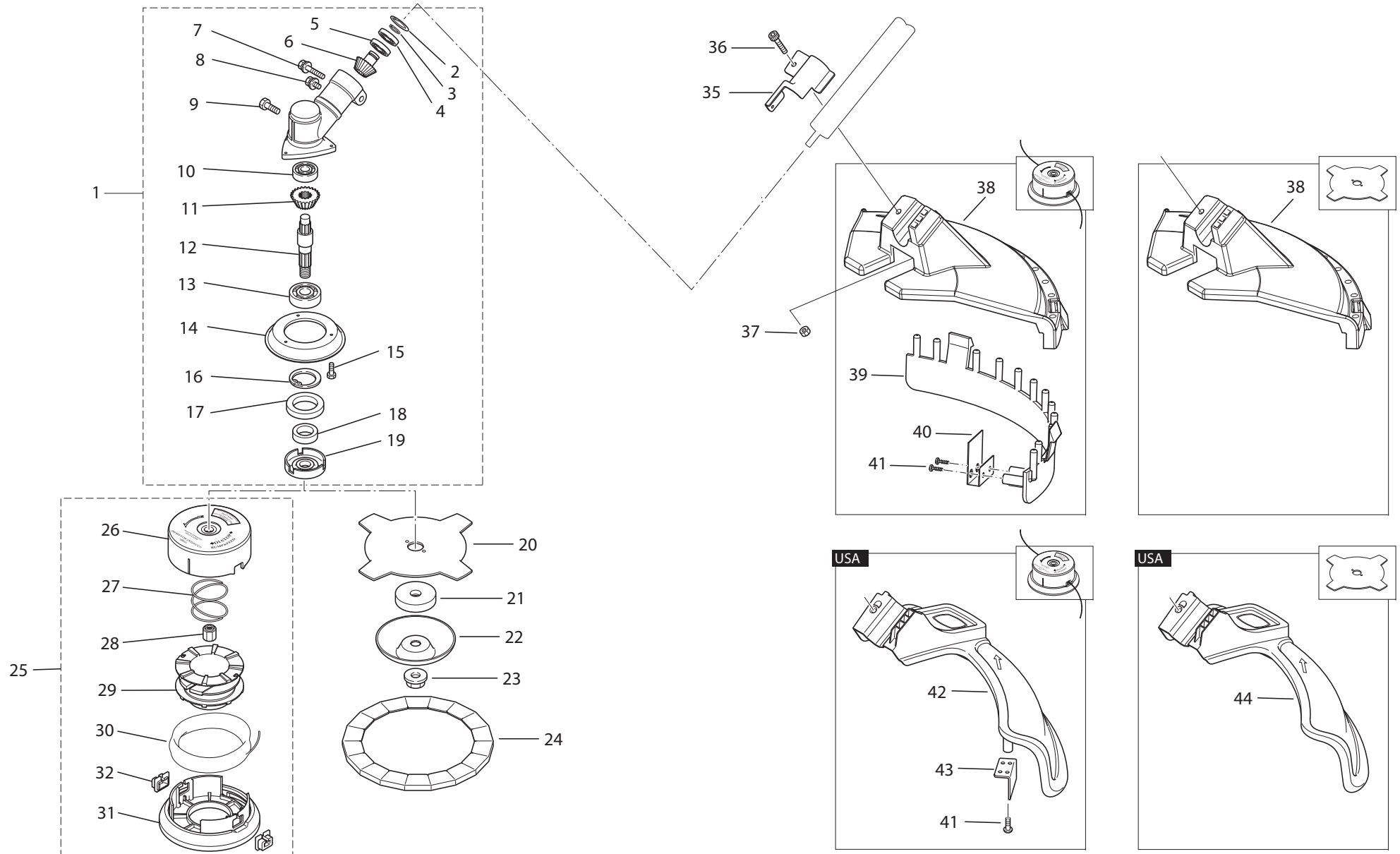

MS-230 C, MS-230 C ,
MS-260 C, MS-260 C , MS-260
U, MS-260 U

13

Getriebe, Schneidwerkzeug
Gear, cutting tools
Engrenage, Outils tranchants
Engranaje, Herramientas de corte

DOLMAR
A member of the **Takita** Group

Seite / Page	Pos.	MS-230 C	MS-230 C (USA)	MS-260 C	MS-260 C (USA)	MS-260 U	MS-260 U (USA)	Teil-Nr. Part No. No. de pièce No. de pieza	Hinweise Notes Renseign. Nota	Bezeichnung	Spezifikation Specification	Description	Désignation	Denominación
13	1	1	1	1	1	1	1	351 503 040		GETRIEBE KPL.		GEAR ASSY	ENGRENAGE COMPL.	ENGRANAJE COMPL.
13	2	1	1	1	1	1	1	352 503 040		SICHERUNGSRING		CIRCLIP	CIRCLIP	ANILLO FIJADOR
13	3	1	1	1	1	1	1	352 503 020		SICHERUNGSRING		CIRCLIP	CIRCLIP	ANILLO FIJADOR
13	4	1	1	1	1	1	1	351 503 048		KUGELLAGER		BALL BEARING	ROULEMENT À BILLES	RODAMIENTO DE BOLAS
13	5	1	1	1	1	1	1	351 503 047		KUGELLAGER		BALL BEARING	ROULEMENT À BILLES	RODAMIENTO DE BOLAS
13	6	1	1	1	1	1	1	351 503 043		KEGELRAD		BEVEL GEAR	ROUE CONIQUE	ENGRANAJE CÓNICO
13	7	1	1	1	1	1	1	352 503 048		6KT-SCHRAUBE		HEX. SCREW	VIS HEX. AVEC RONDELLE	TORNILLO HEXAGONAL
13	8	1	1	1	1	1	1	351 505 047		6KT-SCHRAUBE		SCREW	VIS	TORNILLO
13	9	1	1	1	1	1	1	352 503 022		6KT-SCHRAUBE		HEX. SCREW	VIS HEX. AVEC RONDELLE	TORNILLO HEXAGONAL
13	10	1	1	1	1	1	1	351 503 046		KUGELLAGER		BALL BEARING	ROULEMENT À BILLES	RODAMIENTO DE BOLAS
13	11	1	1	1	1	1	1	351 503 042		KEGELRAD		BEVEL GEAR	ROUE CONIQUE	ENGRANAJE CÓNICO
13	12	1	1	1	1	1	1	351 503 044		WELLE		SHAFT	ARBRE	ÁRBOL
13	13	1	1	1	1	1	1	351 503 049		KUGELLAGER		BALL BEARING	ROULEMENT À BILLES	RODAMIENTO DE BOLAS
13	14	1	1	1	1	1	1	352 503 043		WICKELSCHUTZ		ANTI-CLOGGING DEVICE	PROTECTEUR D'ENROULEMENT	PROTEC. DE ARROLLAMIENTO
13	15	3	3	3	3	3	3	352 503 045		SCHRAUBE		SCREW	VIS	TORNILLO
13	16	1	1	1	1	1	1	352 503 021		SICHERUNGSRING		CIRCLIP	CIRCLIP	ANILLO FIJADOR
13	17	1	1	1	1	1	1	352 503 047		WELLENDICHRING		OIL SEAL	JOINT RADIAL	JUNTA RADIAL
13	18	1	1	1	1	1	1	352 503 046		DIFANZRING		SPACER	ENTRETOISE	ANILLO
13	19	1	1	1	1	1	1	351 503 045		AUFNAHMEscheibe		MOUNTING DISC	DISQUE DE SUPPORT	DISCO DE SUJECIÓN
13	20	1		1		1	1	362 224 140		4-ZAHN-SCHLAGMESSER	230X1.8X25.4 - 4T	STAR BLADE	COUPEAU À 4 DENTS	CUCHILLA DE ACERO DE 4 DIE.
13	21	1		1		1	1	351 510 011		DRUCKSCHEIBE		PRESSURE DISC	DISQUE DE PRESSION	DISCO DE PRESIÓN
13	22	1		1		1	1	351 510 012		GLEITTELLER		SLIDING CUP	BOL DE GLISSEMENT	PLATO DESLIZANTE
13	23	1		1		1	1	351 510 013		MUTTER		NUT	ÉCROU	TUERCA
13	24	1		1		1	1	351 511 032		TRANSPORTSCHUTZ		PROTECTION CASE	ENVELOPPE	ENVOLTURA PROTECTORA
13	25	1	1	1	1			351 502 030		2-FADENKOPF		DUAL LINE TRIMMING HEAD	TÊTE À 2 FILS DE NYLON	CABEZAL DE 2 HILOS DE NILÓN
13	26	1	1	1	1			351 502 031		GEHÄUSE		HOUSING	CARTER	CARTER
13	27	1	1	1	1			351 502 037		FEDER		SPRING	RESSORT	RESORTE
13	28	1	1	1	1			351 502 034		ADAPTER		ADAPTOR	ADAPTEUR	ADAPTADOR
13	29	1	1	1	1			351 502 033		FADENSPULE		THREAD BUSH	DOUILLE DE FIL	BUJE DE HILO
13	30	1	1	1	1			369 224 070		LEISER FADEN	ø2,4 x 15 m	SILENT NYLON LINE	FIL DE COUPE SILENCIEUX	HILO CORTANTE SILENCIOSO
13	31	1	1	1	1			351 502 032		DECKEL		COVER	COUVERCLE	TAPA
13	32	2	2	2	2			351 502 015		FADENBUCHSE		THREAD BUSH	DOUILLE DE FIL	BUJE DE HILO
13	35	1	1	1	1	1	1	351 504 032		SCHUTZHAUBENBEFESTIGUNG		PROTECTION HOOD FASTENING	FIXATION DE CAPOT DE PROTECTION	FIJACIÓN DE CUBIERTA PROTECTORA
13	36	1	1	1	1	1	1	351 504 020		SCHRAUBE		SCREW	VIS	TORNILLO
13	37	1	1	1	1	1	1	351 504 086		MUTTER		NUT	ÉCROU	TUERCA
13	38	1		1		1		351 504 101		SCHUTZHAUBE		PROTECTION HOOD	CAPOT DE PROTECTION	CUBIERTA PROTECTORA
13	39	1		1				351 504 102		SCHUTZLEISTE		GUARD EXTENSION	BANDE DE PROTECTION	BANDA DE PROTECCIÓN
13	40	1						351 504 103		FADENMESSER		LINE CUTTER	COUPEAU DE FIL	CUCHILLA DE HILO
13	40			1				351 504 113		FADENMESSER		LINE CUTTER	COUPEAU DE FIL	CUCHILLA DE HILO
13	41	2	2	2	2			352 506 015		SCHRAUBE		SCREW	VIS	TORNILLO
13	42		1		1			352 504 081		SCHUTZHAUBE		PROTECTION HOOD	CAPOT DE PROTECTION	CUBIERTA PROTECTORA

MS-230 C, MS-230 C ,
MS-260 C, MS-260 C , MS-260
U, MS-260 U

13

Getriebe, Schneidwerkzeug
Gear, cutting tools
Engrenage, Outils tranchants
Engranaje, Herramientas de corte

DOLMAR



A member of the **Takata** Group

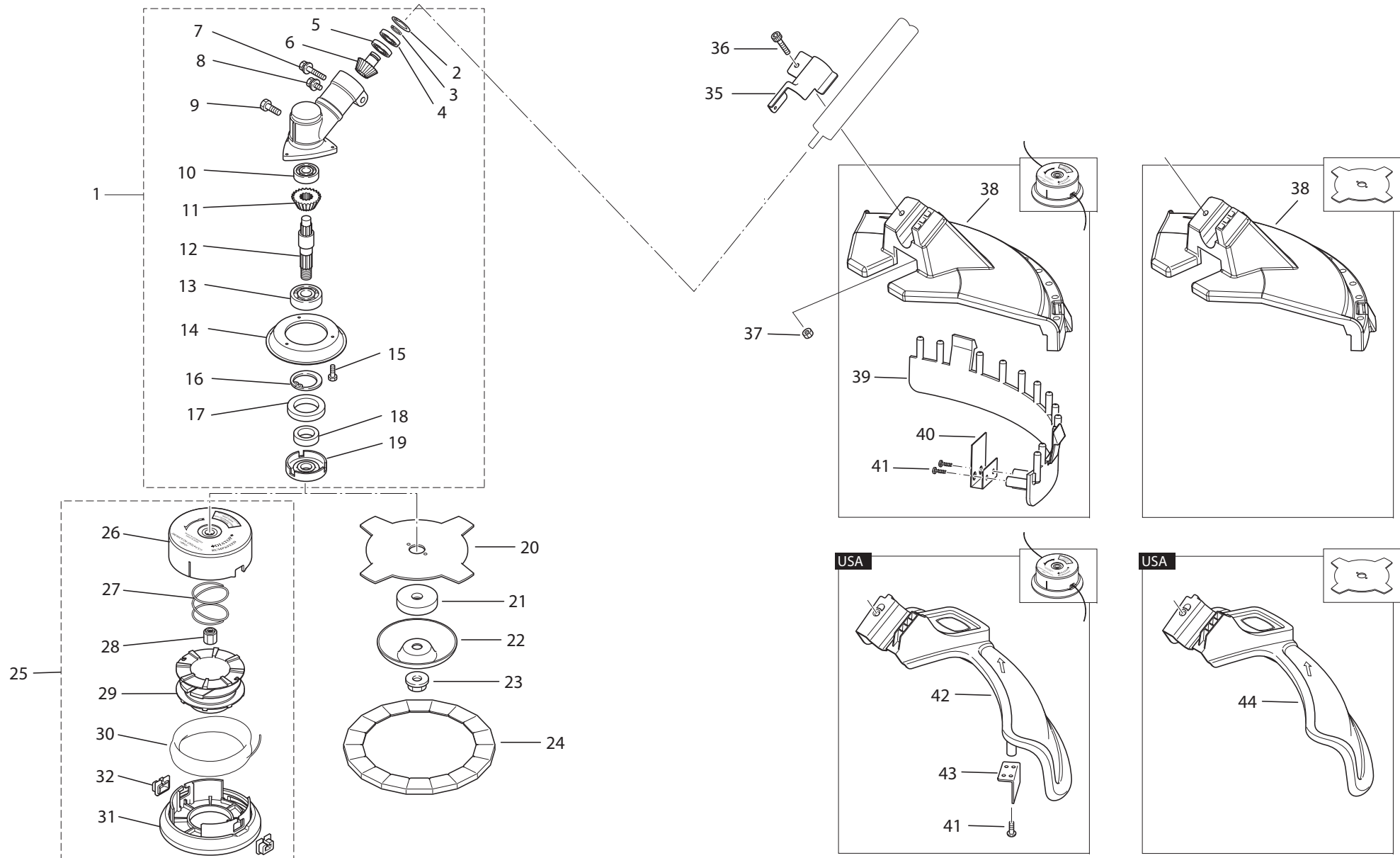

MS-230 C, MS-230 C ,
MS-260 C, MS-260 C , MS-260
U, MS-260 U

13

Getriebe, Schneidwerkzeug
Gear, cutting tools
Engrenage, Outils tranchants
Engranaje, Herramientas de corte



Seite / Page	Pos.	MS-230 C	MS-230 C (USA)	MS-260 C	MS-260 C (USA)	MS-260 U	MS-260 U (USA)	Teil-Nr. Part No. No. de pièce No. de pieza	Hinweise Notes Renseign. Nota	Bezeichnung	Spezifikation Specification	Description	Désignation	Denominación
13	43		1		1			351 504 023		SCHNEIDER		LINE CUTTER	COUPEAU DE FIL	CUCHILLA DE HILO
13	44						1	353 504 050		SCHUTZHAUBE		PROTECTION HOOD	CAPOT DE PROTECTION	CUBIERTA PROTECTORA

MS-230 C, MS-230 C ,
MS-260 C, MS-260 C , MS-260
U, MS-260 U

DOLMAR



A member of the **Takita** Group

	Zeichenerklärung	Key to symbols	Légende	Explicación de símbolos
=> 1999999 2000000 => 2003.04 => TI 2003/07 Acc. = { m Corr.	Produktion bis Serien-Nr. Neues Teil ab Serien-Nr. Neues Teil ab Jahr / Monat Siehe Technische Information Jahr / Nr. Zubehör (nicht im Lieferumfang) Keine Serienausführung, jedoch verwendbar Beinhaltet Positions-Nr. Meterware Druckfehlerberichtigung	Production to serial number New part from serial number New part from Year / Month See Technical Information Year / No. Accessories (not included in the delivery inventory) No standard execution, may be used Contains item number Sold by the meter Error correction	Production jusqu'à n° de série Nouveau pièce à partir du n° de série Nouveau pièce à partir de année / mois Voir information technique année / n° Accessoires (non compris dans la livraison) Aucune exécut. en série, cependant utilisable contient n° de numéro Au mètre Rectification d'erreurs	Producción hasta N° de serie Pieza nueva a partir de N° de serie Pieza nueva a partir de año / mes Véase inform. técnico año / N° Accesorios (no incluido en la extensión del suministro) No es de serie, pero sirve Contiene pos N° Por metro Fe de erratas
	Änderungen vorbehalten	Specifications subject to change without notice	Changements sans préavis	Mejoras constructivas sin previo aviso