

Spare Parts List
Ersatzteilliste
Liste de pièces détachées
Lista de piezas de repuesto

2008-09



(2008):
RM-72.13 H

DOLMAR



A member of the *Makita* Group

995700141 (D, GB, F, E)

(2008): RM-72.13 H

1

RAHMENSATZ
CHASSIS
CHASSIS
CHASSIS

DOLMAR
A member of the *Trakita* Group

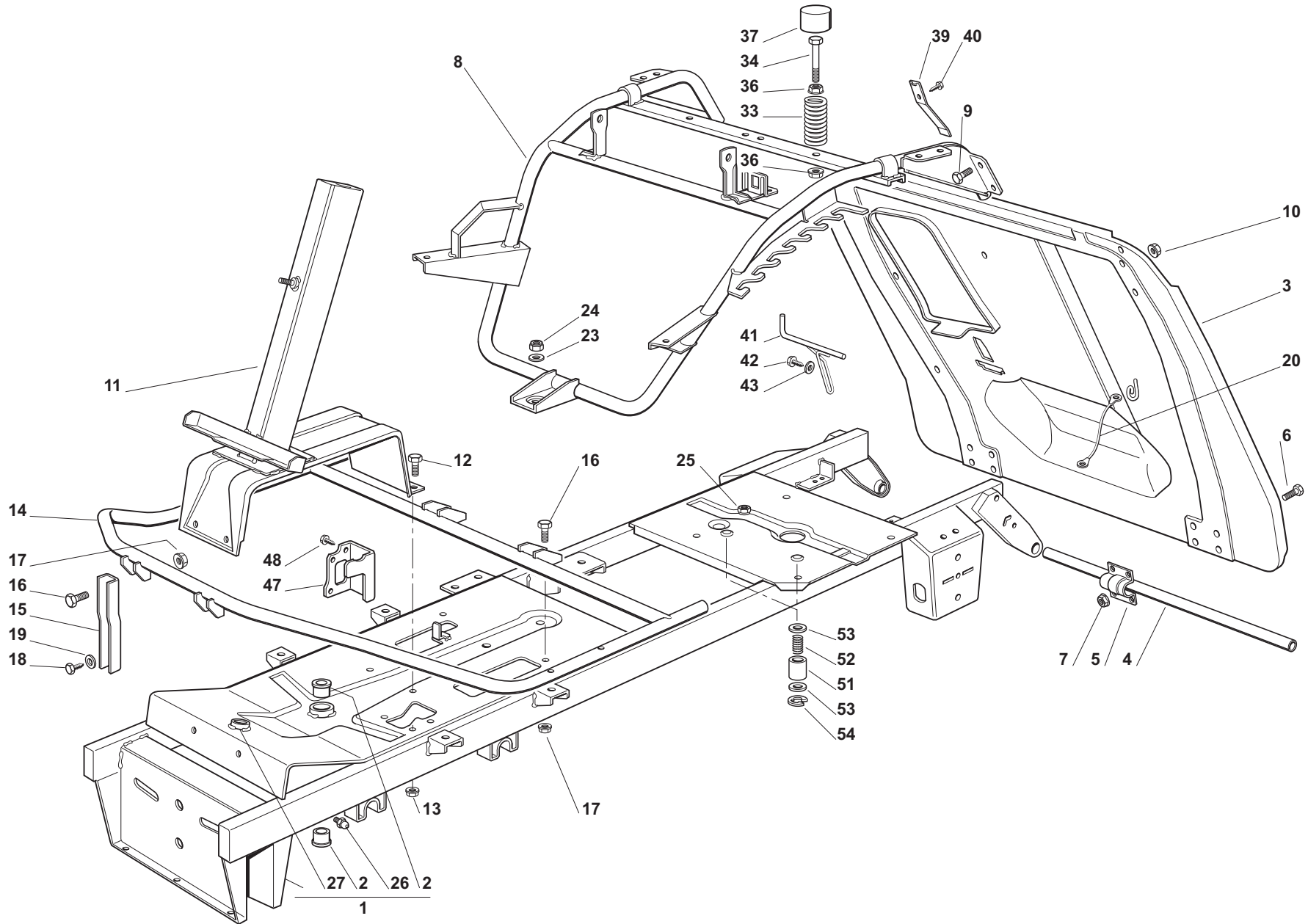

(2008): RM-72.13 H

1

RAHMENSATZ
CHASSIS
CHASSIS
CHASSIS

DOLMARA member of the **Takita** Group

Seite / Page	Pos.	RM-72.13 H	Teil-Nr. Part No. No. de pièce No. de pieza	Hinweise Notes Renseign. Nota	Bezeichnung	Spezifikation Specification	Description	Désignation	Denominación
1	1	1	664 801 135		RAHMENSATZ		CHASSIS	CHASSIS	CHASSIS
1	2	2	664 034 002		BUCHSE		BUSH	DOUILLE	CASQUILLO
1	3	1	664 545 057		PLATTE		PLATE	PLAQUE	PLACA
1	4	1	664 037 000		BOLZEN		PIN	PIVOT	PIVOTE
1	5	2	664 547 012		PLATTE		PLATE	PLAQUE	PLACA
1	6	8	664 791 200		SCHRAUBE		SCREW	VIS	TORNILLO
1	7	8	664 292 102		MUTTER		NUT	ECROU	TUERCA
1	8	1	664 801 127		RAHMENSATZ		CHASSIS	CHASSIS	CHASSIS
1	9	4	664 792 611		SCHRAUBE		SCREW	VIS	TORNILLO
1	10	4	664 293 201		MUTTER		NUT	ECROU	TUERCA
1	11	1	664 783 027		HALTER		SUPPORT	SUPPORT	SOPORTE
1	12	4	664 792 611		SCHRAUBE		SCREW	VIS	TORNILLO
1	13	4	664 293 201		MUTTER		NUT	ECROU	TUERCA
1	14	1	664 801 107		FUSSBRETTALTER		SUPPORT	SUPPORT	SOPORTE
1	15	2	664 787 025		HALTER		SUPPORT	SUPPORT	SOPORTE
1	16	4	664 792 611		SCHRAUBE		SCREW	VIS	TORNILLO
1	17	4	664 293 201		MUTTER		NUT	ECROU	TUERCA
1	18	2	664 734 995		SCHRAUBE		SCREW	VIS	TORNILLO
1	19	2	664 521 331		SCHEIBE		WASHER	RONDELLE	ARANDELA
1	20	1	664 040 300		SEIL		CORD	CORDE	CUERDA
1	23	1	664 523 060		SCHEIBE		WASHER	RONDELLE	ARANDELA
1	24	1	664 155 000		MUTTER		NUT	ECROU	TUERCA
1	25	1	664 500 090		MUTTER		NUT	ECROU	TUERCA
1	26	1	664 379 511		FETTBUCHSE		GREASE DISPENSER	GRAISSEUR	CASQUILLO DE ENGRASE
1	27	1	664 034 001		BUCHSE		BUSH	DOUILLE	CASQUILLO
1	33	2	664 430 575		FEDER		SPRING	RESSORT	MUELLE
1	34	2	664 943 050		SCHRAUBE		SCREW	VIS	TORNILLO
1	36	4	664 293 201		MUTTER		NUT	ECROU	TUERCA
1	37	2	664 122 000		SCHUTZKASTEN		HOOD	PROTECTEUR	CUBIERTA
1	39	1	664 430 554		FEDER		SPRING	RESSORT	MUELLE
1	40	1	664 735 110		SCHRAUBE		SCREW	VIS	TORNILLO
1	41	1	664 294 001		FÜHRUNG		GUIDE	GUIDE	GUÍA
1	42	1	664 735 120		SCHRAUBE		SCREW	VIS	TORNILLO
1	43	1	664 523 040		SCHEIBE		WASHER	RONDELLE	ARANDELA
1	47	1	664 772 095		HALTER		CLAMP	ETRIER	SOPORTE
1	48	2	664 735 106		SCHRAUBE		SCREW	VIS	TORNILLO
1	51	2	664 047 012		BUCHSE		BUSH	DOUILLE	CASQUILLO
1	52	2	664 430 577		FEDER		SPRING	RESSORT	MUELLE
1	53	4	664 670 008		SCHEIBE		WASHER	RONDELLE	ARANDELA
1	54	2	664 999 955		SPRENGRING		SNAP RING	ANNEAU RESSORT	ANILLO DE SUJECIÓN

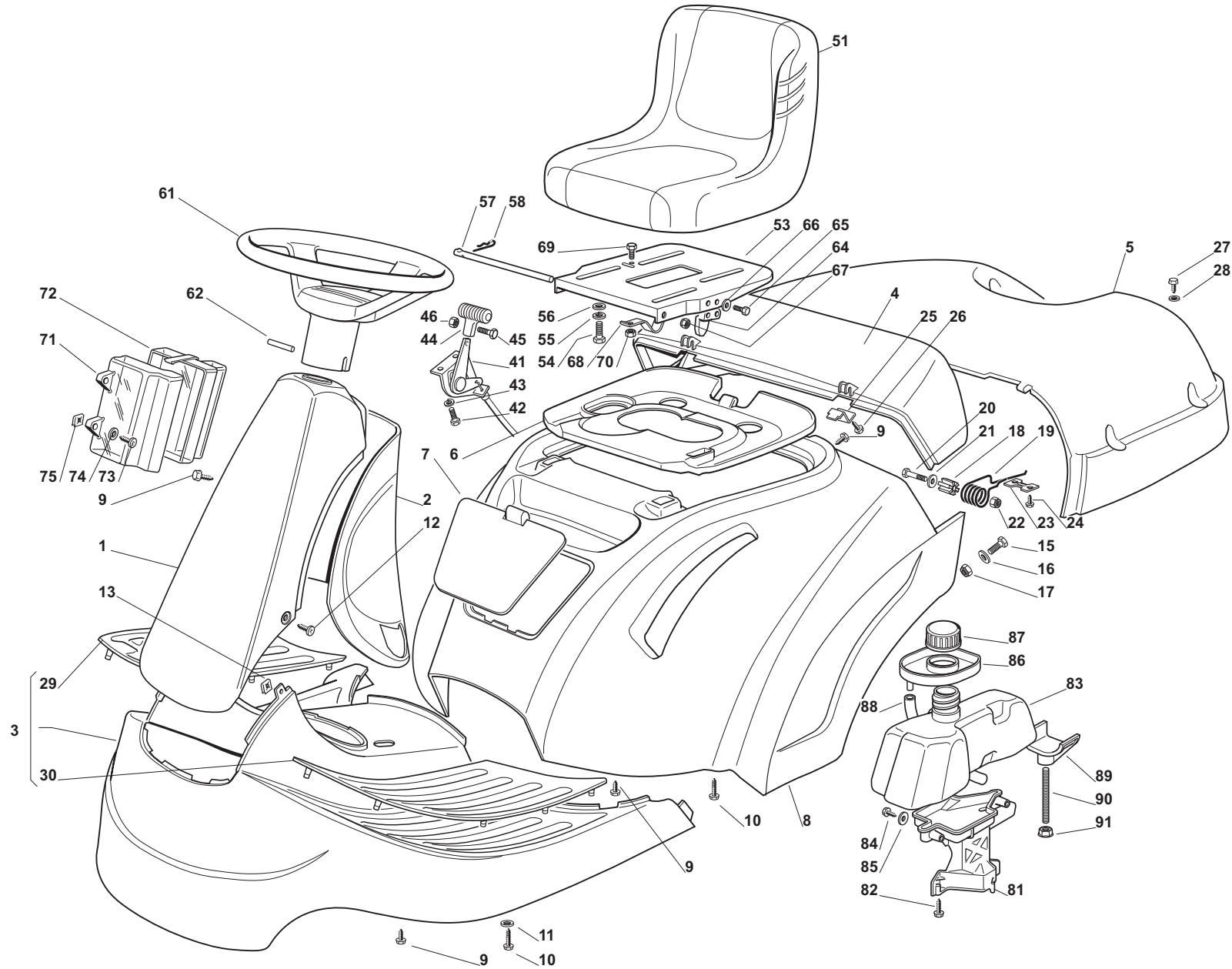



Seite / Page	Pos.	RM-72.13 H	Teil-Nr. Part No. No. de pièce No. de pieza	Hinweise Notes Renseign. Nota	Bezeichnung	Spezifikation Specification	Description	Désignation	Denominación
2	1	1	664 598 076		VORDERDECKEL ROT		FRONT COVER	COUVERCLE AVANT	CUBIERTA DELANTERA
2	2	1	664 600 111		HINTERDECKEL ROT		REAR COVER	COUVERCLE ARRIER	CUBIERTA TRASERA
2	3	1	664 110 130		FUSSBRETTDECKEL ROT		FOOTBOARD COVER	COUVRE MARCHEPIED	CUBIERTA DEL APOYAPIE
2	4	1	664 110 353		HAUBE ROT		GRASS-CATCHER COVER	COUVRE-BAC	CUBIERTA
2	5	1	664 110 354		HAUBE ROT		GRASS-CATCHER COVER	COUVRE-BAC	CUBIERTA
2	6	1	664 110 306		MOTORABDECKUNG		COVER	COUVERCLE	CUBIERTA
2	7	1	664 109 515		DECKEL ROT		FRONT COVER	COUVERCLE AVANT	TAPA
2	8	1	664 110 129		RADABDECKUNG, ROT		COVER	COUVERCLE	CONSOLA
2	9	10	664 735 402		SCHRAUBE		SCREW	VIS	TORNILLO
2	10	8	664 735 410		SCHRAUBE		SCREW	VIS	TORNILLO
2	11	4	664 523 040		SCHEIBE		WASHER	RONDELLE	ARANDELA
2	12	2	664 727 790		SCHRAUBE		SCREW	VIS	TORNILLO
2	13	2	664 437 503		PLATTE		PLATE	PLAQUE	PLACA
2	15	2	664 791 200		SCHRAUBE		SCREW	VIS	TORNILLO
2	16	2	664 523 040		SCHEIBE		WASHER	RONDELLE	ARANDELA
2	17	2	664 154 510		MUTTER		NUT	ECROU	TUERCA
2	18	2	664 047 003		BUCHSE		BUSH	DOUILLE	CASQUILLO
2	19	2	664 430 551		FEDER		SPRING	RESSORT	MUELLE
2	20	2	664 691 200		SCHRAUBE		SCREW	VIS	TORNILLO
2	21	2	664 523 070		SCHEIBE		WASHER	RONDELLE	ARANDELA
2	22	2	664 155 000		MUTTER		NUT	ECROU	TUERCA
2	23	2	664 546 001		PLATTE		PLATE	PLAQUE	PLACA
2	24	4	664 735 402		SCHRAUBE		SCREW	VIS	TORNILLO
2	25	2	664 546 003		PLATTE		PLATE	PLAQUE	PLACA
2	26	2	664 735 402		SCHRAUBE		SCREW	VIS	TORNILLO
2	27	4	664 729 601		SCHRAUBE		SCREW	VIS	TORNILLO
2	28	4	664 521 331		SCHEIBE		WASHER	RONDELLE	ARANDELA
2	29	1	664 110 314		FUSSBRETTDECKEL RECHTS		RIGHT FOOTBOARD COVER	COUVRE MARCHEPIED DRO.	TAPA APOYAPIES DER.
2	30	1	664 110 315		FUSSBRETTDECKEL LINKS		LEFT FOOTBOARD COVER	COUVRE MARCHEPIED GAU.	CUBIERTA APOYAPIES IZ.
2	41	1	664 999 250		GASZUG		BOWDEN CABLE	CÂBLE BOWDEN	TRACCIÓN BOWDEN
2	42	2	664 788 512		SCHRAUBE		SCREW	VIS	TORNILLO
2	43	2	664 581 200		FEDERRING		GROWER	GROWER	ARANDELA ELÁSTICA
2	44	1	664 394 501		GRIFF		HANDLE	POIGNEE	MANETA
2	45	1	664 726 399		SCHRAUBE		SCREW	VIS	TORNILLO
2	46	1	664 290 800		MUTTER		NUT	ECROU	TUERCA
2	51	1	664 722 463		SITZ		SEAT	SIEGE	ASIENTO
2	53	1	664 547 033		PLATTE		PLATE	PLAQUE	PLACA
2	54	4	664 793 101		SCHRAUBE		SCREW	VIS	TORNILLO
2	55	4	664 583 500		FEDERRING		GROWER	GROWER	ARANDELA ELÁSTICA
2	56	4	664 523 060		SCHEIBE		WASHER	RONDELLE	ARANDELA
2	57	1	664 864 052		BOLZEN		PIN	PIVOT	PIVOTE
2	58	1	664 487 997		SPLINT		COTTER PIN	GOUPILLE	PASADOR
2	61	1	664 961 216		LENKRAD		STEERING WHEEL	VOLANT	VOLANTE

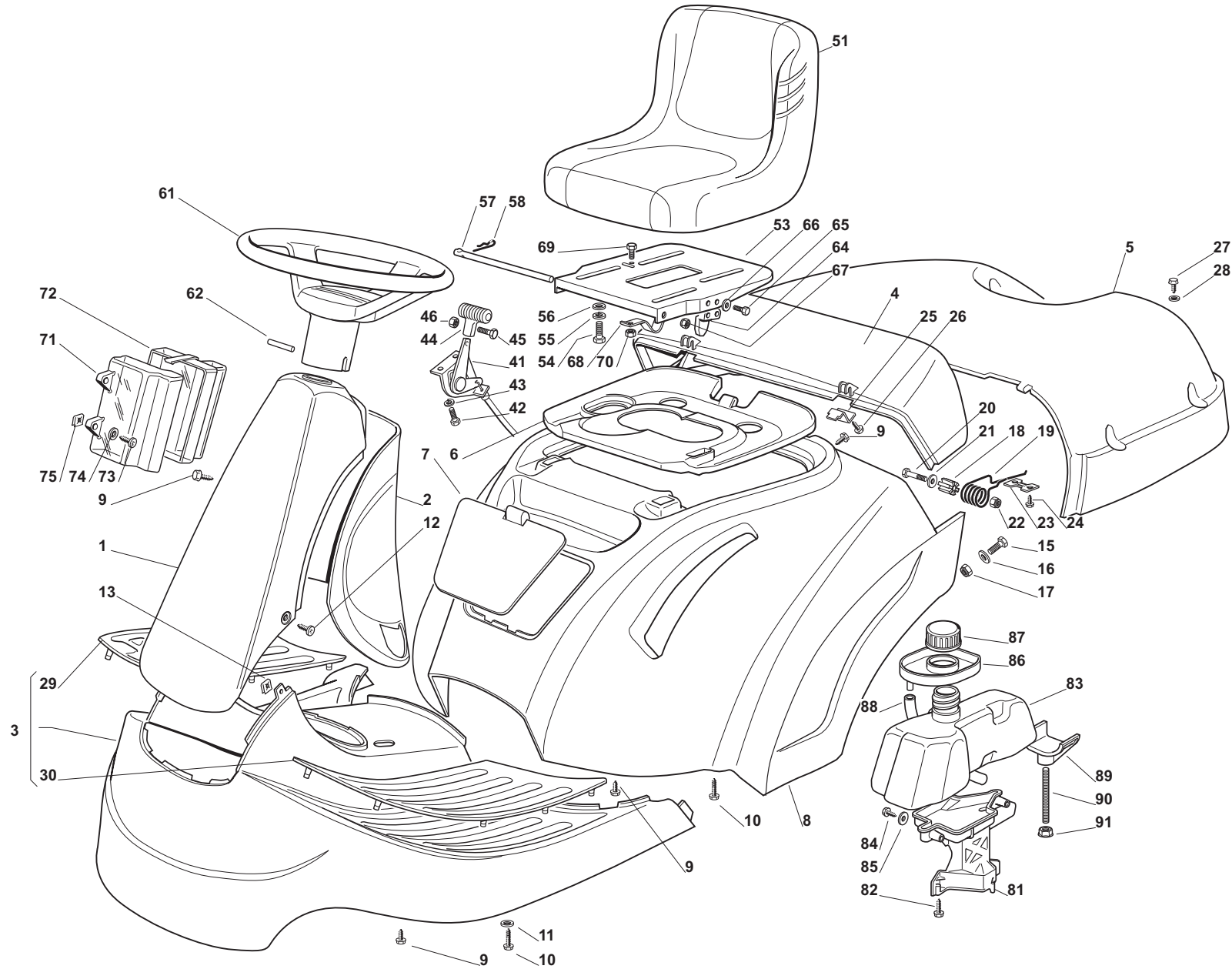

(2008): RM-72.13 H

2

KARROSSERIE
BODY
CARROSSERIE
CARROCERÍA**DOLMAR**A member of the **Takita** Group

Seite / Page	Pos.	RM-72.13 H	Teil-Nr. Part No. No. de pièce No. de pieza	Hinweise Notes Renseignn. Nota	Bezeichnung	Spezifikation Specification	Description	Désignation	Denominación
2	62	1	664 620 299		STIFT		PIN	GOUPILLE	PASADOR
2	64	1	664 063 021		NOCKEN		CAM	CAME	LEVA
2	65	2	664 789 100		SCHRAUBE		SCREW	VIS	TORNILLO
2	66	2	664 523 020		SCHEIBE		WASHER	RONDELLE	ARANDELA
2	67	2	664 154 330		MUTTER		NUT	ECROU	TUERCA
2	68	1	664 430 223		FEDER		SPRING	RESSORT	MUELLE
2	69	1	664 789 000		SCHRAUBE		SCREW	VIS	TORNILLO
2	70	1	664 154 330		MUTTER		NUT	ECROU	TUERCA
2	71	1	664 600 020		OBERSCHUTZ		UPPER GUARD	PROTECTION SUPERIEUR	PROTECCIÓN SUPERIOR
2	72	1	664 600 021		UNTERSCHUTZ		LOWER GUARD	PROTECTION INFERIEUR	PROTECCIÓN INFERIOR
2	73	2	664 728 460		SCHRAUBE		SCREW	VIS	TORNILLO
2	74	2	664 521 320		SCHEIBE		WASHER	RONDELLE	ARANDELA
2	75	2	664 437 502		PLATTE		PLATE	PLAQUE	PLACA
2	81	1	664 787 062		HALTER		SUPPORT	SUPPORT	SOPORTE
2	82	3	664 735 410		SCHRAUBE		SCREW	VIS	TORNILLO
2	83	1	664 733 003		TANK		TANK	RESERVOIR	DEPÓSITO
2	84	2	664 735 410		SCHRAUBE		SCREW	VIS	TORNILLO
2	85	2	664 523 040		SCHEIBE		WASHER	RONDELLE	ARANDELA
2	86	1	664 600 061		SCHUTZ		PROTECTION	PROTECTION	PROTECCIÓN
2	87	1	664 795 000		TANKVERSCHLUSS		CAP	BOUCHON	TAPÓN DEL DEPÓSITO
2	88	1	664 869 014		ROHR		TUBE	TUBE	TUBO
2	89	1	664 787 063		HALTER		SUPPORT	SUPPORT	SOPORTE
2	90	1	664 510 118		BOLZEN		PIN	PIVOT	PIVOTE
2	91	2	664 293 201		MUTTER		NUT	ECROU	TUERCA

(2008): RM-72.13 H

3

LENKGETRIEBE
STEERING
BARRE DE DIRECTION
BARRA DE DIRECCIÓN

DOLMAR
A member of the *Trakita* Group

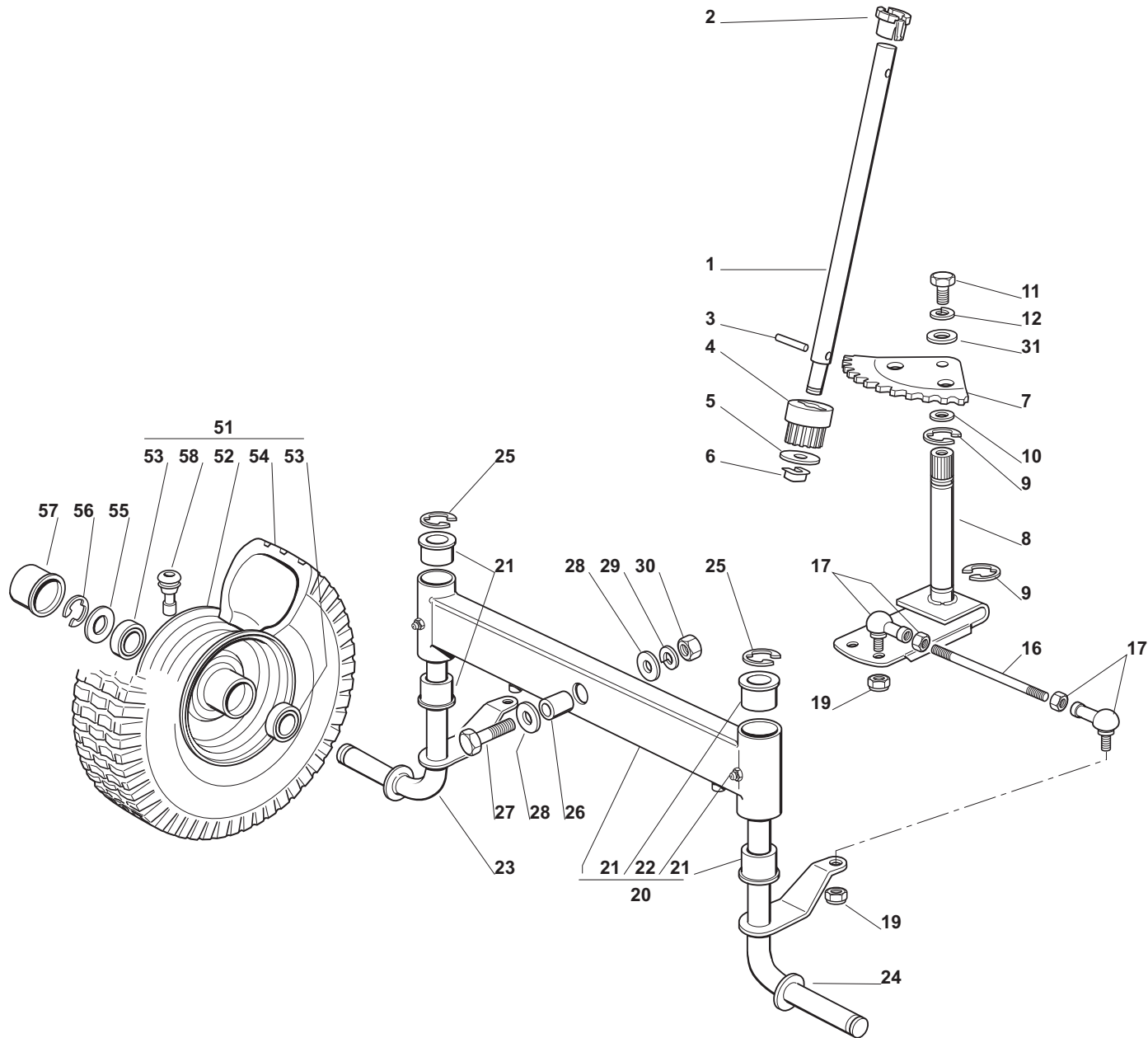

(2008): RM-72.13 H

3

LENKGETRIEBE
STEERING
BARRE DE DIRECTION
BARRA DE DIRECCIÓN

DOLMARA member of the **Makita** Group

Seite / Page	Pos.	RM-72.13 H	Teil-Nr. Part No. No. de pièce No. de pieza	Hinweise Notes Renseign. Nota	Bezeichnung	Spezifikation Specification	Description	Désignation	Denominación
3	1	1	664 520 050		LENKSÄULE		STEERING COLUMN	COLONNE DE DIRECTION	COLUMNA DE DIRECCIÓN
3	2	1	664 038 004		BUCHSE		BUSH	DOUILLE	CASQUILLO
3	3	1	664 622 650		STIFT		PIN	GOUPILLE	PASADOR
3	4	1	664 570 050		RITZEL		PINION	PIGNON	PIÑÓN
3	5	1	664 521 370		SCHEIBE		WASHER	RONDELLE	ARANDELA
3	6	1	664 436 030		PLÄTTCHEN		PLATE	PLAQUETTE	PLAQUITA
3	7	1	664 735 551		LENKWELLE		STEERING SHAFT	ARBRE DIRECTION	ÁRBOL DE DIRECCIÓN
3	8	1	664 999 501		WELLE		SHAFT	ARBRE	ÁRBOL
3	9	2	664 001 000		SPRENGRING		SNAP RING	ANNEAU RESSORT	ANILLO DE SUJECCIÓN
3	10	0-2	664 520 031		SCHEIBE		WASHER	RONDELLE	ARANDELA
3	11	1	664 793 102		SCHRAUBE		SCREW	VIS	TORNILLO
3	12	1	664 583 500		FEDERRING		GROWER	GROWER	ARANDELA ELÁSTICA
3	16	2	664 840 050		SPANNSTANGE		TIE ROD	TIRANT	SENSOR
3	17	4	664 746 600		GELENK		JOINT	JOINT	ARTICULACIÓN
3	19	4	664 156 602		MUTTER		NUT	ECROU	TUERCA
3	20	1	664 034 057		KIPPEBEL		EQUALIZER	BALANCIER	PALANCA
3	21	4	664 034 002		BUCHSE		BUSH	DOUILLE	CASQUILLO
3	22	2	664 379 511		FETTBUCHSE		GREASE DISPENSER	GRAISSEUR	CASQUILLO DE ENGRASE
3	23	1	664 230 401		ACHSSCHENKEL RECHTS		STUB AXLE RIGHT	FUSEAU DROITE	MANGUETA DERECHA
3	24	1	664 230 403		ACHSSCHENKEL LINKS		STUB AXLE LEFT	FUSEAU GAUCHE	MANGUETA IZQUIERDA
3	25	2	664 001 000		SPRENGRING		SNAP RING	ANNEAU RESSORT	ANILLO DE SUJECCIÓN
3	26	1	664 160 016		DISTANZRING		SPACER	ENTRETOISE	DISTANCIADOR
3	27	1	664 692 695		SCHRAUBE		SCREW	VIS	TORNILLO
3	28	2	664 523 100		SCHEIBE		WASHER	RONDELLE	ARANDELA
3	29	1	664 587 100		FEDERRING		GROWER	GROWER	ARANDELA ELÁSTICA
3	30	1	664 295 300		MUTTER		NUT	ECROU	TUERCA
3	31	1	664 521 350		SCHEIBE		WASHER	RONDELLE	ARANDELA
3	51	2	664 680 052		VORDERRAD		FRONT WHEEL	ROUE AVANT	RUEDA DELANTERA
3	52	2	664 044 000		FELGE		RIMM	JANTE	LLANTA
3	53	4	664 122 210		LAGER		BEARING	COUSSINET	RODAMIENTO
3	54	2	664 590 050		REIFEN		SHOE	PNEU	NEUMÁTICO
3	55	2	664 670 005		SCHEIBE		WASHER	RONDELLE	ARANDELA
3	56	2	664 001 000		SPRENGRING		SNAP RING	ANNEAU RESSORT	ANILLO DE SUJECCIÓN
3	57	2	664 110 230		NABENDECKEL		HUB COVER	COUVRE MOYEU	TAPACUBOS
3	58	2	664 950 000		VENTIL		VALVE	SOUPAPE	VÁLVULA

(2008): RM-72.13 H

4y

GETRIEBE UND BREMSE ANTRIEB
DRIVE AND BRAKE CONTROLS
COMMANDE TRANSMISSION ET FREIN
ACCIONAMIENTO TRANSMISIÓN Y FRENOS

DOLMAR
A member of the *Trakita* Group

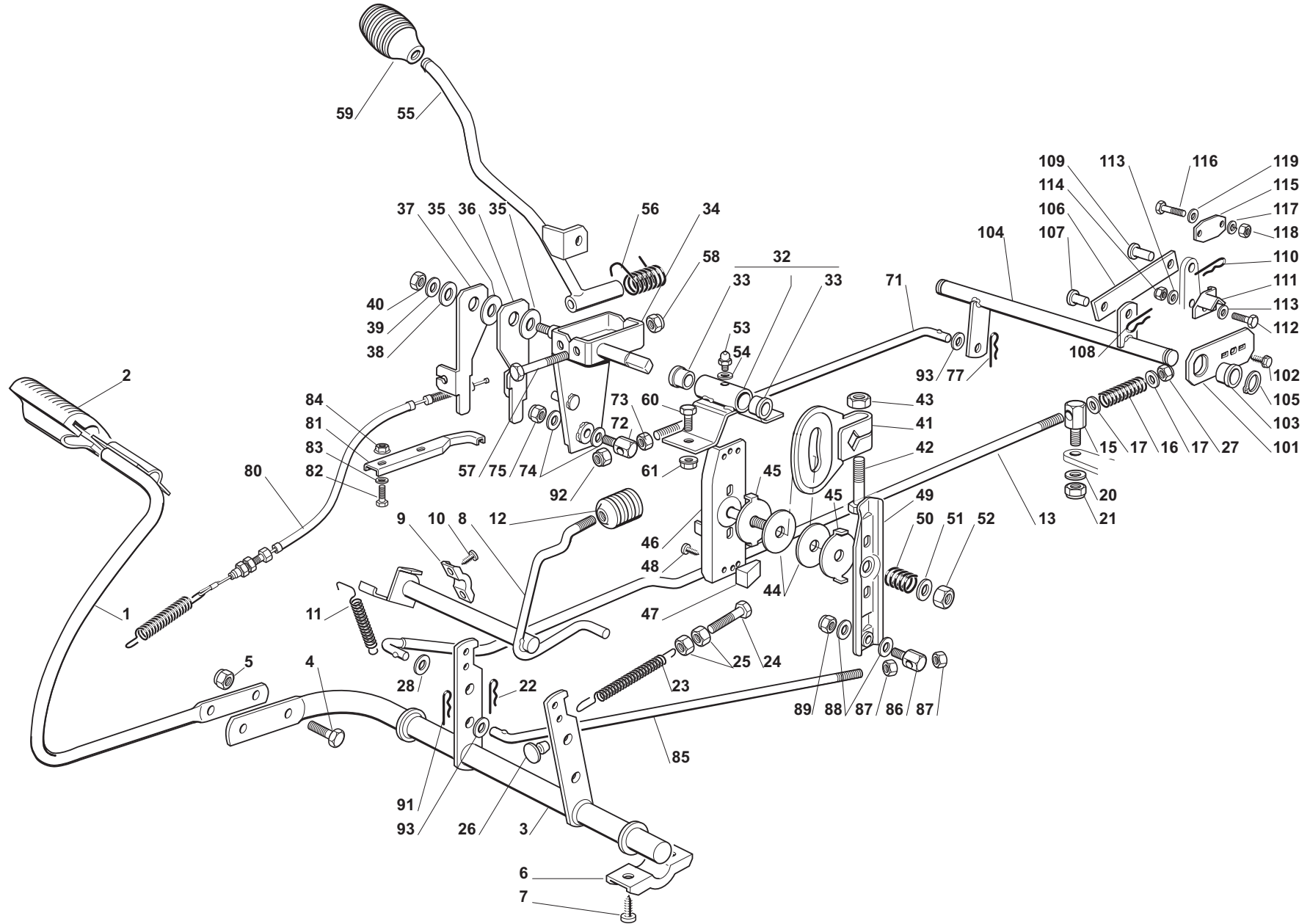

(2008): RM-72.13 H

4y

GETRIEBE UND BREMSE ANTRIEB
DRIVE AND BRAKE CONTROLS
COMMANDE TRANSMISSION ET FREIN
ACCIONAMIENTO TRANSMISIÓN Y FRENOS

DOLMARA member of the **Takita** Group

Seite / Page	Pos.	RM-72.13 H	Teil-Nr. Part No. No. de pièce No. de pieza	Hinweise Notes Renseign. Nota	Bezeichnung	Spezifikation Specification	Description	Désignation	Denominación
4y	1	1	664 503 001		PEDAL		PEDAL	PEDAL	PEDAL
4y	2	1	664 110 267		PEDALGUMMI		CLAMP COVER	COUVRE ETRIER	GOMA DEL PEDAL
4y	3	1	664 001 015		ACHSE		AXLE	AXE	EJE
4y	4	2	664 793 301		SCHRAUBE		SCREW	VIS	TORNILLO
4y	5	2	664 155 000		MUTTER		NUT	ECROU	TUERCA
4y	6	2	664 546 015		PLATTE		PLATE	PLAQUE	PLACA
4y	7	4	664 731 350		SCHRAUBE		SCREW	VIS	TORNILLO
4y	8	1	664 001 011		ACHSE		AXLE	AXE	EJE
4y	9	2	664 547 049		PLATTE		PLATE	PLAQUE	PLACA
4y	10	4	664 731 601		SCHRAUBE		SCREW	VIS	TORNILLO
4y	11	1	664 430 552		FEDER		SPRING	RESSORT	MUELLE
4y	12	1	664 395 050		KNOPF		KNOB	POIGNEE	BOTÓN
4y	13	1	664 034 070		STANGE		ROD	BARRE	BARRA
4y	15	1	664 510 067		BOLZEN		PIN	PIVOT	PIVOTE
4y	16	1	664 430 236		FEDER		SPRING	RESSORT	MUELLE
4y	17	2	664 521 360		SCHEIBE		WASHER	RONDELLE	ARANDELA
4y	20	1	664 523 050		SCHEIBE		WASHER	RONDELLE	ARANDELA
4y	21	1	664 155 000		MUTTER		NUT	ECROU	TUERCA
4y	22	1	664 487 997		SPLINT		COTTER PIN	GOUPILLE	PASADOR
4y	23	1	664 430 210		FEDER		SPRING	RESSORT	MUELLE
4y	24	1	664 943 005		SCHRAUBE		SCREW	VIS	TORNILLO
4y	25	2	664 293 200		MUTTER		NUT	ECROU	TUERCA
4y	26	1	664 275 000		GUMMI		GROMMET	CAOUTCHOUC	CAUCHO
4y	27	1	664 156 602		MUTTER		NUT	ECROU	TUERCA
4y	28	1	664 670 011		SCHEIBE		WASHER	RONDELLE	ARANDELA
4y	32	1	664 773 568		LAGERBUCHSE		BRACKET WITH BUSH	INGSETRIER AVEC DOUILLES	CASQUILLO DEL RODAMIENTO
4y	33	2	664 045 080		LAGER		BEARING	COUSSINET	RODAMIENTO
4y	34	1	664 773 561		HEBEL		LEVER	LEVIER	PALANCA
4y	35	2	664 672 151		SCHEIBE		WASHER	RONDELLE	ARANDELA
4y	36	1	664 772 101		HEBEL LINKS		LEVER LEFT	LEVIER GAUCHE	PALANCA IZQUIERDA
4y	37	1	664 772 103		HEBEL RECHTS		LEVER RIGHT	LEVIER DROITE	PALANCA DERECHA
4y	38	1	664 672 152		SCHEIBE		WASHER	RONDELLE	ARANDELA
4y	39	1	664 523 060		SCHEIBE		WASHER	RONDELLE	ARANDELA
4y	40	1	664 155 010		MUTTER		NUT	ECROU	TUERCA
4y	41	1	664 734 055		SEKTOR		SECTOR	SECTEUR	SECTOR
4y	42	1	664 794 900		SCHRAUBE		SCREW	VIS	TORNILLO
4y	43	1	664 155 020		MUTTER		NUT	ECROU	TUERCA
4y	44	2	664 158 000		SCHEIBE		WASHER	RONDELLE	ARANDELA
4y	45	2	664 670 053		SCHEIBE		WASHER	RONDELLE	ARANDELA
4y	46	1	664 773 565		ZUGPLATTE		CLAMP	ETRIER	PLACA DE TRACCIÓN
4y	47	2	664 063 020		NOCKEN		CAM	CAME	LEVA
4y	48	2	664 735 110		SCHRAUBE		SCREW	VIS	TORNILLO
4y	49	1	664 773 563		HEBEL		LEVER	LEVIER	PALANCA

(2008): RM-72.13 H

4y

GETRIEBE UND BREMSE ANTRIEB
DRIVE AND BRAKE CONTROLS
COMMANDE TRANSMISSION ET FREIN
ACCIONAMIENTO TRANSMISIÓN Y FRENOS

DOLMAR



A member of the *Trakita* Group

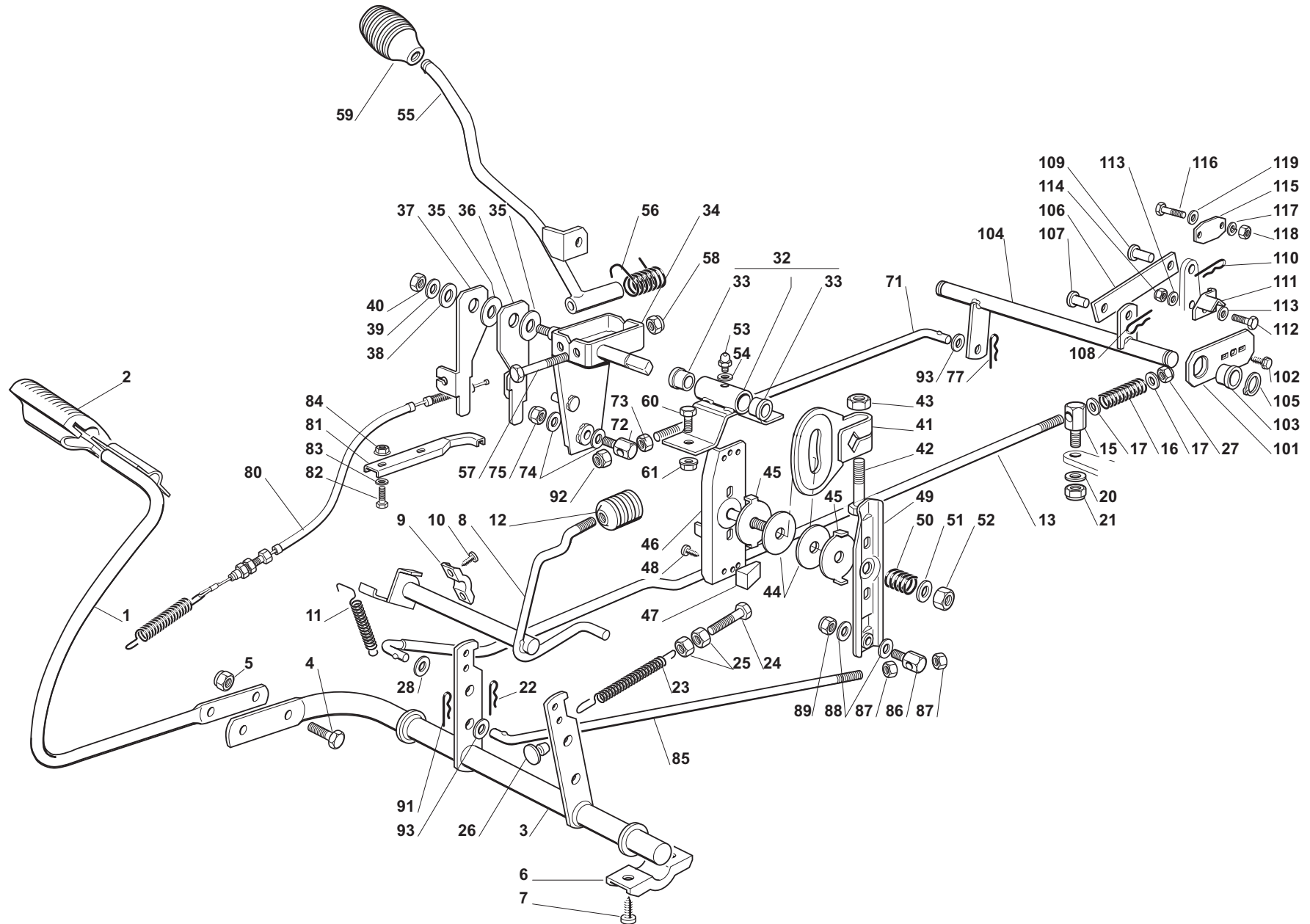

(2008): RM-72.13 H

4y

GETRIEBE UND BREMSE ANTRIEB
DRIVE AND BRAKE CONTROLS
COMMANDE TRANSMISSION ET FREIN
ACCIONAMIENTO TRANSMISIÓN Y FRENOS

DOLMAR
A member of the **Takita** Group

Seite / Page	Pos.	RM-72.13 H	Teil-Nr. Part No. No. de pièce No. de pieza	Hinweise Notes Renseign. Nota	Bezeichnung	Spezifikation Specification	Description	Désignation	Denominación
4y	50	1	664 430 560		FEDER		SPRING	RESSORT	MUELLE
4y	51	1	664 670 008		SCHEIBE		WASHER	RONDELLE	ARANDELA
4y	52	1	664 155 020		MUTTER		NUT	ECROU	TUERCA
4y	53	1	664 379 511		FETTBUCHSE		GREASE DISPENSER	GRAISSEUR	CASQUILLO DE ENGRASE
4y	54	1	664 521 330		SCHEIBE		WASHER	RONDELLE	ARANDELA
4y	55	1	664 317 051		HEBEL		LEVER	LEVIER	PALANCA
4y	56	1	664 430 226		FEDER		SPRING	RESSORT	MUELLE
4y	57	1	664 692 050		SCHRAUBE		SCREW	VIS	TORNILLO
4y	58	1	664 155 000		MUTTER		NUT	ECROU	TUERCA
4y	59	1	664 394 508		KNAUF		KNOB	POIGNEE	MANETA
4y	60	2	664 793 102		SCHRAUBE		SCREW	VIS	TORNILLO
4y	61	2	664 293 201		MUTTER		NUT	ECROU	TUERCA
4y	71	1	664 034 071		STANGE		ROD	BARRE	BARRA
4y	72	1	664 510 040		BOLZEN		PIN	PIVOT	PIVOTE
4y	73	1	664 293 200		MUTTER		NUT	ECROU	TUERCA
4y	74	2	664 670 011		SCHEIBE		WASHER	RONDELLE	ARANDELA
4y	75	1	664 155 010		MUTTER		NUT	ECROU	TUERCA
4y	77	1	664 487 997		SPLINT		COTTER PIN	GOUPILLE	PASADOR
4y	80	1	664 207 101		KABEL		CABLE	FIL	CABLE
4y	81	1	664 772 105		FÜHRUNG		CLAMP	ETRIER	GUÍA
4y	82	2	664 791 400		SCHRAUBE		SCREW	VIS	TORNILLO
4y	83	2	664 521 330		SCHEIBE		WASHER	RONDELLE	ARANDELA
4y	84	2	664 292 102		MUTTER		NUT	ECROU	TUERCA
4y	85	1	664 034 074		STANGE		ROD	BARRE	BARRA
4y	86	1	664 510 040		BOLZEN		PIN	PIVOT	PIVOTE
4y	87	2	664 293 200		MUTTER		NUT	ECROU	TUERCA
4y	88	2	664 670 011		SCHEIBE		WASHER	RONDELLE	ARANDELA
4y	89	1	664 155 010		MUTTER		NUT	ECROU	TUERCA
4y	91	1	664 487 997		SPLINT		COTTER PIN	GOUPILLE	PASADOR
4y	92	1	664 155 000		MUTTER		NUT	ECROU	TUERCA
4y	93	2	664 670 011		SCHEIBE		WASHER	RONDELLE	ARANDELA
4y	101	2	664 546 047		PLATTE		PLATE	PLAQUE	PLACA
4y	102	2	664 735 121		SCHRAUBE		SCREW	VIS	TORNILLO
4y	103	2	664 040 614		LAGER		BEARING	COUSSINET	RODAMIENTO
4y	104	1	664 001 023		ACHSE		AXLE	AXE	EJE
4y	105	2	664 608 900		SICHERUNGSRING		RETAINING RING	ANNEAU DE SÛRETÉ	ANILLO DE SEGURIDAD
4y	106	1	664 034 073		STANGE		ROD	BARRE	BARRA
4y	107	1	664 510 111		BOLZEN		PIN	PIVOT	PIVOTE
4y	108	1	664 487 997		SPLINT		COTTER PIN	GOUPILLE	PASADOR
4y	109	1	664 510 110		BOLZEN		PIN	PIVOT	PIVOTE
4y	110	1	664 487 997		SPLINT		COTTER PIN	GOUPILLE	PASADOR
4y	111	1	664 063 022		NOCKEN		CAM	CAME	LEVA
4y	112	1	664 791 400		SCHRAUBE		SCREW	VIS	TORNILLO

(2008): RM-72.13 H

4y

GETRIEBE UND BREMSE ANTRIEB
DRIVE AND BRAKE CONTROLS
COMMANDE TRANSMISSION ET FREIN
ACCIONAMIENTO TRANSMISSION Y FRENOS

DOLMAR
A member of the *Trakita* Group

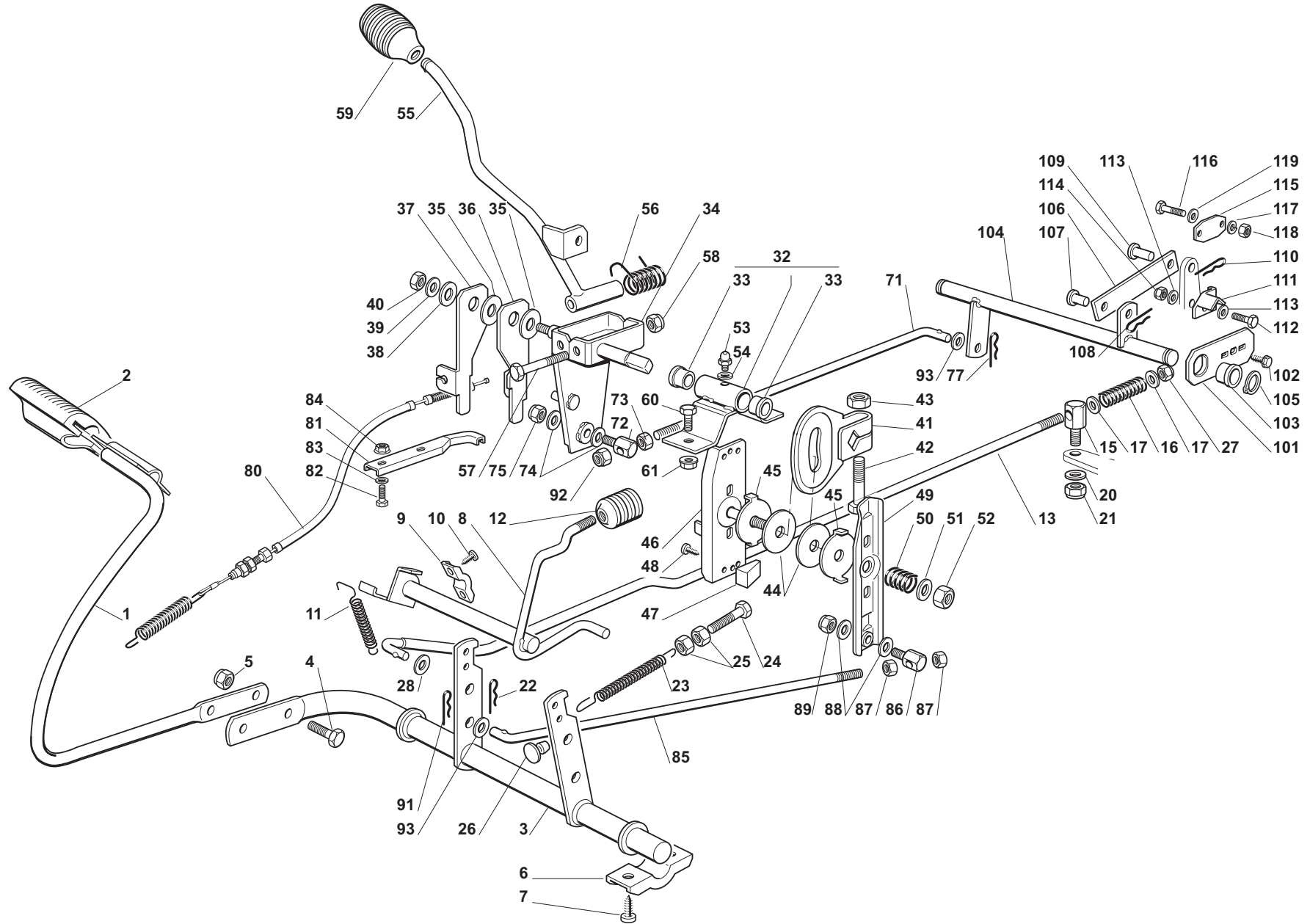

(2008): RM-72.13 H

4y

GETRIEBE UND BREMSE ANTRIEB
DRIVE AND BRAKE CONTROLS
COMMANDE TRANSMISSION ET FREIN
ACCIONAMIENTO TRANSMISIÓN Y FRENOS



Seite / Page	Pos.	RM-72.13 H	Teil-Nr. Part No. No. de pièce No. de pieza	Hinweise Notes Renseign. Nota	Bezeichnung	Spezifikation Specification	Description	Désignation	Denominación
4y	113	2	664 521 330		SCHEIBE		WASHER	RONDELLE	ARANDELA
4y	114	1	664 154 510		MUTTER		NUT	ECROU	TUERCA
4y	115	1	664 546 019		PLATTE		PLATE	PLAQUE	PLACA
4y	116	2	664 735 602		SCHRAUBE		SCREW	VIS	TORNILLO
4y	117	2	664 581 100		FEDERING		SPRING RING	BAGUE À RESSORT	ARANDELA ELÁSTICA
4y	118	2	664 290 791		MUTTER		NUT	ECROU	TUERCA
4y	119	2	664 540 020		SCHEIBE		WASHER	RONDELLE	ARANDELA

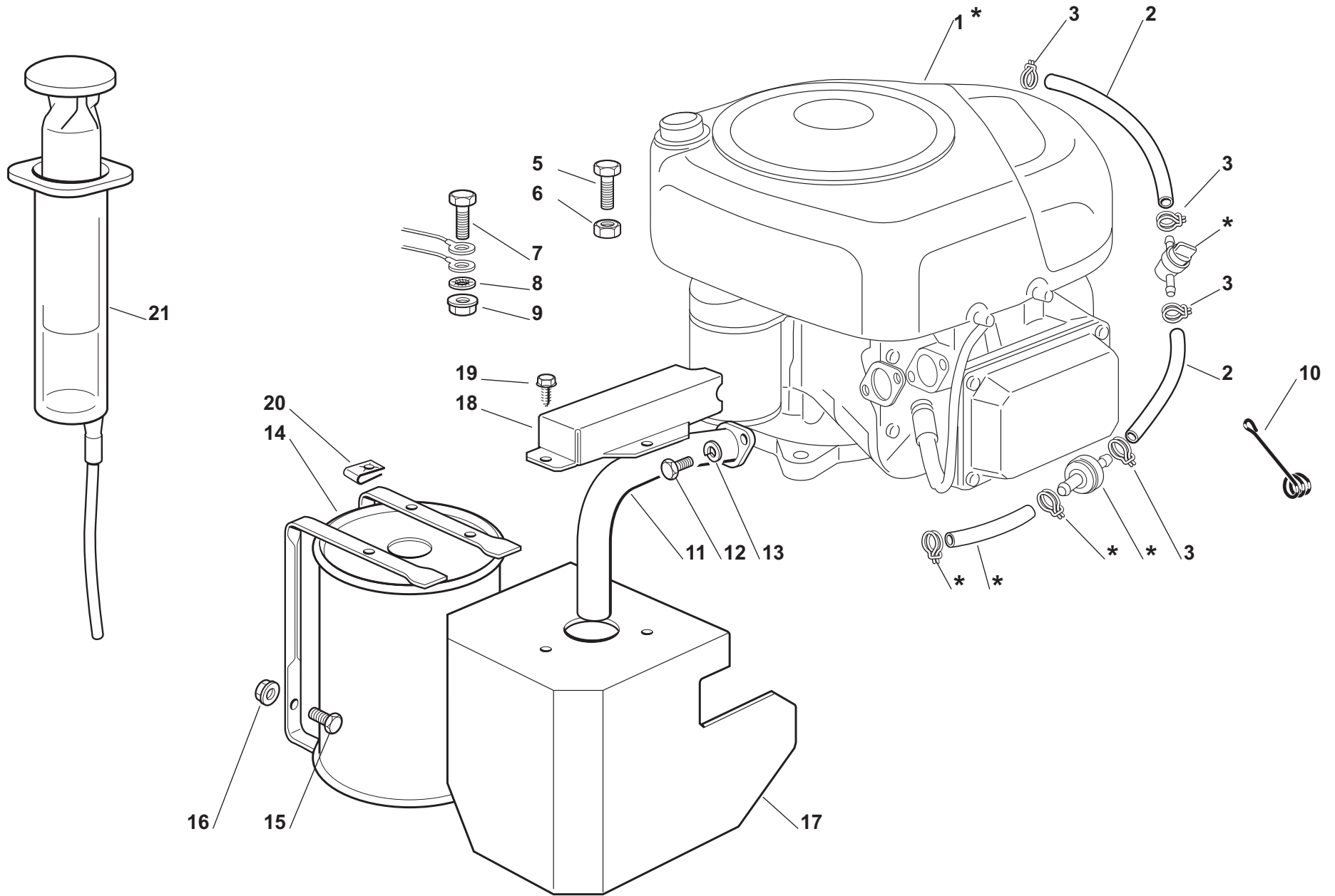

(2008): RM-72.13 H

5Motor
Motor
Moteur
Motor**DOLMAR**A member of the **Takita** Group

Seite / Page	Pos.	RM-72.13 H	Teil-Nr. Part No. No. de pièce No. de pieza	Hinweise Notes Renseign. Nota	Bezeichnung	Spezifikation Specification	Description	Désignation	Denominación
5	*	x			ZUM AUSTAUSCH DER MIT «*» GEKENNZEICHNETEN TEILE, WENDEN SIE SICH AN DEN KUNDENDIENST DES MOTORHERSTELLERS.		TO REPLACE THE PARTS MARKED «*» SEEK ASSISTANCE FROM THE ENGINE MANUFACTURER'S AFTER SALES SERVICE.	POUR LE REMPLACEMENT DES PIÈCES MARQUÉES AVEC «*» S'ADRESSER AU SERVICE APRÈS VENTES DU CONSTRUCTEUR DU MOTEUR.	PARA RECAMBIO DE LAS PIEZAS MARCADO CON «*» FAVOR SE DIRIGEN AL SERVICIO TÉCNICO DEL FABRICANTE DEL MOTOR.
5	1*	1			TECUMSEH MOTOR		TECUMSEH ENGINE	TECUMSEH MOTEUR	TECUMSEH MOTOR
5	2	2	664 869 035		ROHR		TUBE	TUBE	TUBO
5	3	4	664 869 035		ROHR		TUBE	TUBE	TUBO
5	5	3	664 691 100		SCHRAUBE		SCREW	VIS	TORNILLO
5	6	3	664 154 210		MUTTER		NUT	ECROU	TUERCA
5	7	1	664 691 115		SCHRAUBE		SCREW	VIS	TORNILLO
5	8	1	664 540 260		SCHEIBE		WASHER	RONDELLE	ARANDELA
5	9	1	664 154 210		MUTTER		NUT	ECROU	TUERCA
5	10	1	664 430 239		FEDER		SPRING	RESSORT	MUELLE
5	11	1	664 738 225		AUSPUFFANSCHLUSS		EXHAUST CONNECTION	CONNEXION ECHAPPEMENT	CONEXIÓN DEL ESCAPE
5	12	2	664 737 450		SCHRAUBE		SCREW	VIS	TORNILLO
5	13	2	664 583 500		FEDERRING		GROWER	GROWER	ARANDELA ELÁSTICA
5	14	1	664 750 006		AUSPUFF		MUFFLER	SILENCIEUX	SILENCIADOR
5	15	2	664 793 102		SCHRAUBE		SCREW	VIS	TORNILLO
5	16	2	664 154 210		MUTTER		NUT	ECROU	TUERCA
5	17	1	664 598 081		AUSPUFFSCHUTZ		GUARD	PROTECTION	PROTECCIÓN
5	18	1	664 600 137		SCHUTZ		PROTECTION	PROTECTION	PROTECCIÓN
5	19	3	664 729 601		SCHRAUBE		SCREW	VIS	TORNILLO
5	20	3	664 437 504		PLATTE		PLATE	PLAQUE	PLACA
5	21	1	664 718 000		SPRITZE		SYRINGE	SIRINGUE	JERINGUILLA

(2008): RM-72.13 H

6y

Getriebe
Gear
Engrenage
Engranaje

DOLMAR
A member of the *Trakita* Group

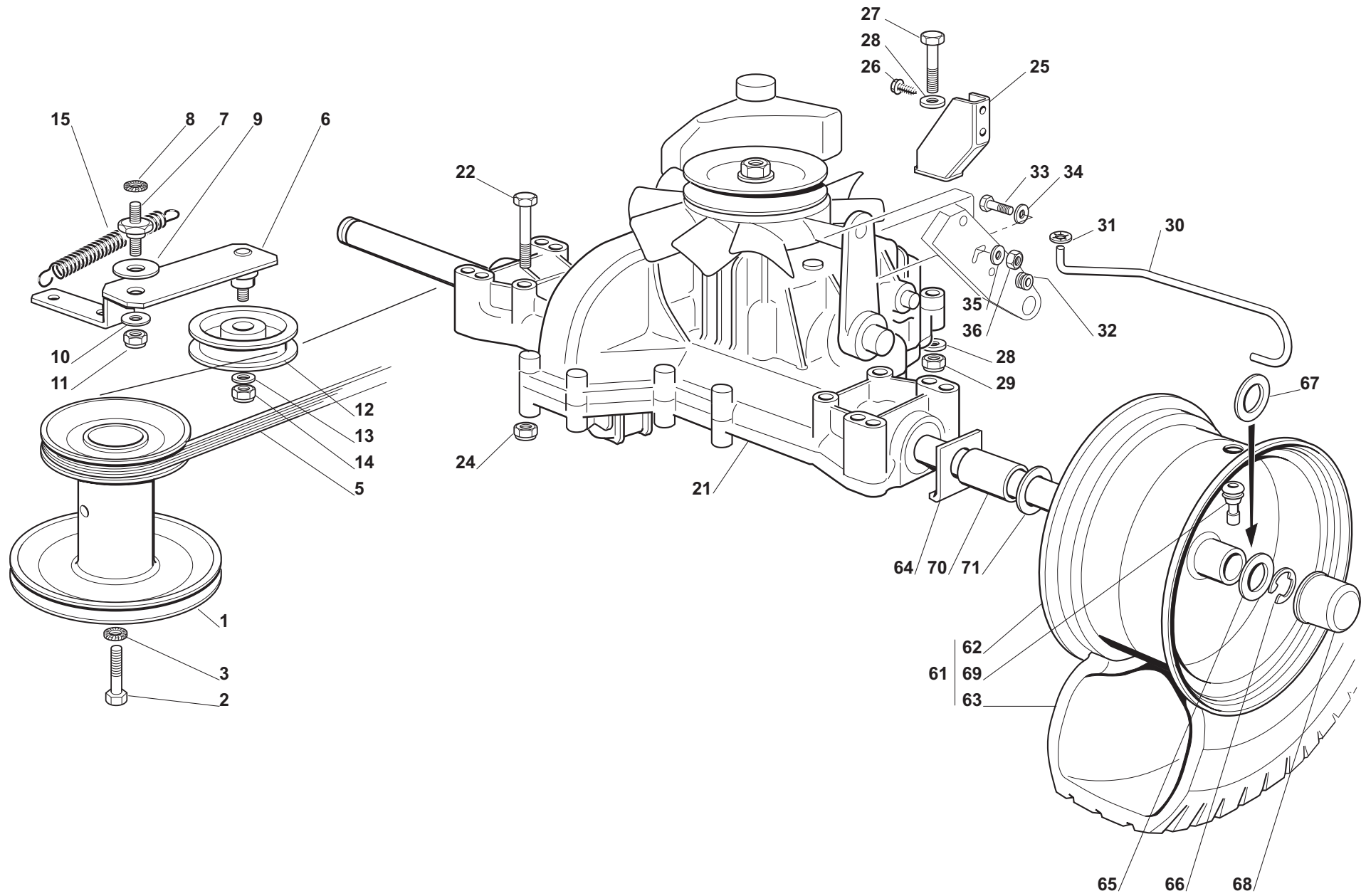

(2008): RM-72.13 H

6yGetriebe
Gear
Engrenage
Engranaje**DOLMAR**A member of the **Takita** Group

Seite / Page	Pos.	RM-72.13 H	Teil-Nr. Part No. No. de pièce No. de pieza	Hinweise Notes Renseign. Nota	Bezeichnung	Spezifikation Specification	Description	Désignation	Denominación
6y	1	1	664 604 005		RIEMENSCHLEIBE		PULLEY	POULIE	POLEA
6y	2	1	664 737 310		SCHRAUBE		SCREW	VIS	TORNILLO
6y	3	1	664 543 000		SCHEIBE		WASHER	RONDELLE	ARANDELA
6y	5	1	664 061 404		RIEMEN		BELT	COURROIE	CORREA
6y	6	1	664 317 081		HEBEL		LEVER	LEVIER	PALANCA
6y	7	1	664 510 096		BOLZEN		PIN	PIVOT	PIVOTE
6y	8	1	664 540 260		SCHEIBE		WASHER	RONDELLE	ARANDELA
6y	9	1	664 672 151		SCHEIBE		WASHER	RONDELLE	ARANDELA
6y	10	1	664 670 011		SCHEIBE		WASHER	RONDELLE	ARANDELA
6y	11	1	664 155 010		MUTTER		NUT	ECROU	TUERCA
6y	12	1	664 601 554		RIEMENSCHLEIBE		PULLEY	POULIE	POLEA
6y	13	1	664 523 060		SCHEIBE		WASHER	RONDELLE	ARANDELA
6y	14	1	664 155 000		MUTTER		NUT	ECROU	TUERCA
6y	15	1	664 446 402		FEDER		SPRING	RESSORT	MUELLE
6y	21	1	664 400 965		HINTERACHSE		REAR AXLE	AXE ARRIERE	EJE TRASERO, ENGRANAJE CPL.
6y	22	4	664 691 800		SCHRAUBE		SCREW	VIS	TORNILLO
6y	24	4	664 154 210		MUTTER		NUT	ECROU	TUERCA
6y	25	1	664 783 019		HALTER		SUPPORT	SUPPORT	SOPORTE
6y	26	1	664 735 121		SCHRAUBE		SCREW	VIS	TORNILLO
6y	27	1	664 691 200		SCHRAUBE		SCREW	VIS	TORNILLO
6y	28	1	664 521 350		SCHEIBE		WASHER	RONDELLE	ARANDELA
6y	29	1	664 155 000		MUTTER		NUT	ECROU	TUERCA
6y	30	1	664 034 069		HEBEL		LEVER	LEVIER	PALANCA
6y	31	1	664 000 930		SPRENGRING		SAFETY WASHER	RONDELLE DE SÉCURITÉ	ANILLO DE SEGURIDAD
6y	32	1	664 564 512		KABELDURCHGANG		FAIR LEAD	PASSE CABLE	SUJETACABLE
6y	33	1	664 793 301		SCHRAUBE		SCREW	VIS	TORNILLO
6y	34	1	664 523 060		SCHEIBE		WASHER	RONDELLE	ARANDELA
6y	35	1	664 521 350		SCHEIBE		WASHER	RONDELLE	ARANDELA
6y	36	1	664 155 000		MUTTER		NUT	ECROU	TUERCA
6y	61	2	664 680 050		HINTERRAD		WHEEL	ROUE	RUEDA
6y	62	2	664 044 001		HINTERRAD FELGE		RIMM	BANDAGE ROUE	LLANTA RUEDA TRASERA
6y	63	2	664 590 051		REIFEN		SHOE	PNEU	NEUMÁTICO
6y	64	2	664 670 017		SCHEIBE		WASHER	RONDELLE	ARANDELA
6y	65	2	664 670 005		SCHEIBE		WASHER	RONDELLE	ARANDELA
6y	66	2	664 001 010		SPRENGRING		SNAP RING	ANNEAU RESSORT	ANILLO DE SUJECIÓN
6y	67	0-4	664 670 006		SCHEIBE		WASHER	RONDELLE	ARANDELA
6y	68	2	664 110 230		NABENDECKEL		HUB COVER	COUVRE MOYEU	TAPACUBOS
6y	69	2	664 950 000		VENTIL		VALVE	SOUPAPE	VÁLVULA
6y	70	2	664 160 031		DISTANZSTÜCK		SPACER	ENTRETOISE	SEPARADOR
6y	71	2	664 670 005		SCHEIBE		WASHER	RONDELLE	ARANDELA

(2008): RM-72.13 H

7

SCHNEIDWERKZEUG AUFHEBESATZ
CUTTING PLATE LIFTING
SOULEVEMENT PLATEAU DE COUPE
HERRAMIENTA DE CORTE PLATO DE ELEVACIÓN

DOLMAR
A member of the *Trakita* Group

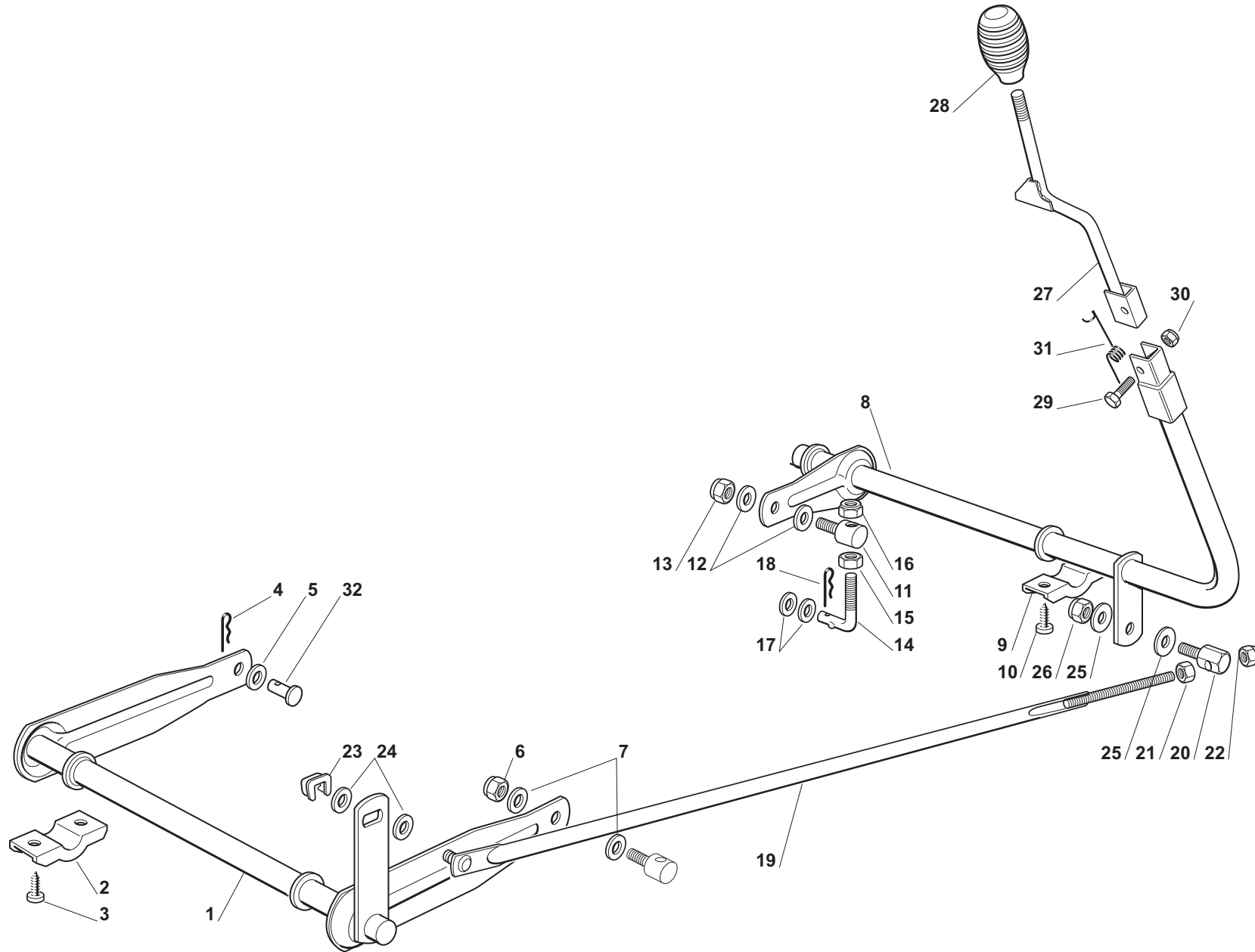

(2008): RM-72.13 H

7

SCHNEIDWERKZEUG AUFHEBESATZ
CUTTING PLATE LIFTING
SOULEVEMENT PLATEAU DE COUPE
HERRAMIENTA DE CORTE PLATO DE ELEVACIÓN

DOLMARA member of the **Takita** Group

Seite / Page	Pos.	RM-72.13 H	Teil-Nr. Part No. No. de pièce No. de pieza	Hinweise Notes Renseign. Nota	Bezeichnung	Spezifikation Specification	Description	Désignation	Denominación
7	1	1	664 001 025		ACHSE		AXLE	AXE	EJE
7	2	2	664 546 015		PLATTE		PLATE	PLAQUE	PLACA
7	3	4	664 731 350		SCHRAUBE		SCREW	VIS	TORNILLO
7	4	1	664 487 997		SPLINT		COTTER PIN	GOUPILLE	PASADOR
7	5	1	664 670 008		SCHEIBE		WASHER	RONDELLE	ARANDELA
7	6	1	664 156 602		MUTTER		NUT	ECROU	TUERCA
7	7	2	664 670 008		SCHEIBE		WASHER	RONDELLE	ARANDELA
7	8	1	664 001 005		ACHSE		AXLE	AXE	EJE
7	9	2	664 546 015		PLATTE		PLATE	PLAQUE	PLACA
7	10	4	664 731 350		SCHRAUBE		SCREW	VIS	TORNILLO
7	11	1	664 510 007		BOLZEN		PIN	PIVOT	PIVOTE
7	12	2	664 670 008		SCHEIBE		WASHER	RONDELLE	ARANDELA
7	13	1	664 156 602		MUTTER		NUT	ECROU	TUERCA
7	14	1	664 840 003		SPANNSTANGE		TIE ROD	TIRANT	SENSOR
7	15	1	664 295 200		MUTTER		NUT	ECROU	TUERCA
7	16	1	664 156 602		MUTTER		NUT	ECROU	TUERCA
7	17	2	664 672 150		SCHEIBE		WASHER	RONDELLE	ARANDELA
7	18	1	664 487 997		SPLINT		COTTER PIN	GOUPILLE	PASADOR
7	19	1	664 002 051		STAB		ROD	TIGE	VARILLA
7	20	1	664 510 040		BOLZEN		PIN	PIVOT	PIVOTE
7	21	1	664 293 200		MUTTER		NUT	ECROU	TUERCA
7	22	1	664 155 000		MUTTER		NUT	ECROU	TUERCA
7	23	1	664 436 050		PLATTE		PLATE	PLAQUE	PLACA
7	24	2	664 670 011		SCHEIBE		WASHER	RONDELLE	ARANDELA
7	25	2	664 670 011		SCHEIBE		WASHER	RONDELLE	ARANDELA
7	26	1	664 155 000		MUTTER		NUT	ECROU	TUERCA
7	27	1	664 317 065		HEBEL		LEVER	LEVIER	PALANCA
7	28	1	664 394 510		GRIFF		KNOB	POIGNEE	MANETA
7	29	1	664 674 700		SCHRAUBE		SCREW	VIS	TORNILLO
7	30	1	664 154 510		MUTTER		NUT	ECROU	TUERCA
7	31	1	664 430 555		FEDER		SPRING	RESSORT	MUELLE
7	32	1	664 510 114		BOLZEN		PIN	PIVOT	PIVOTE

(2008): RM-72.13 H

8

SCHNEIDWERKZEUG (1)
CUTTING PLATE (1)
PLATEAU DE COUPE (1)
HERRAMIENTA DE CORTE (1)

DOLMAR
A member of the *Takita* Group

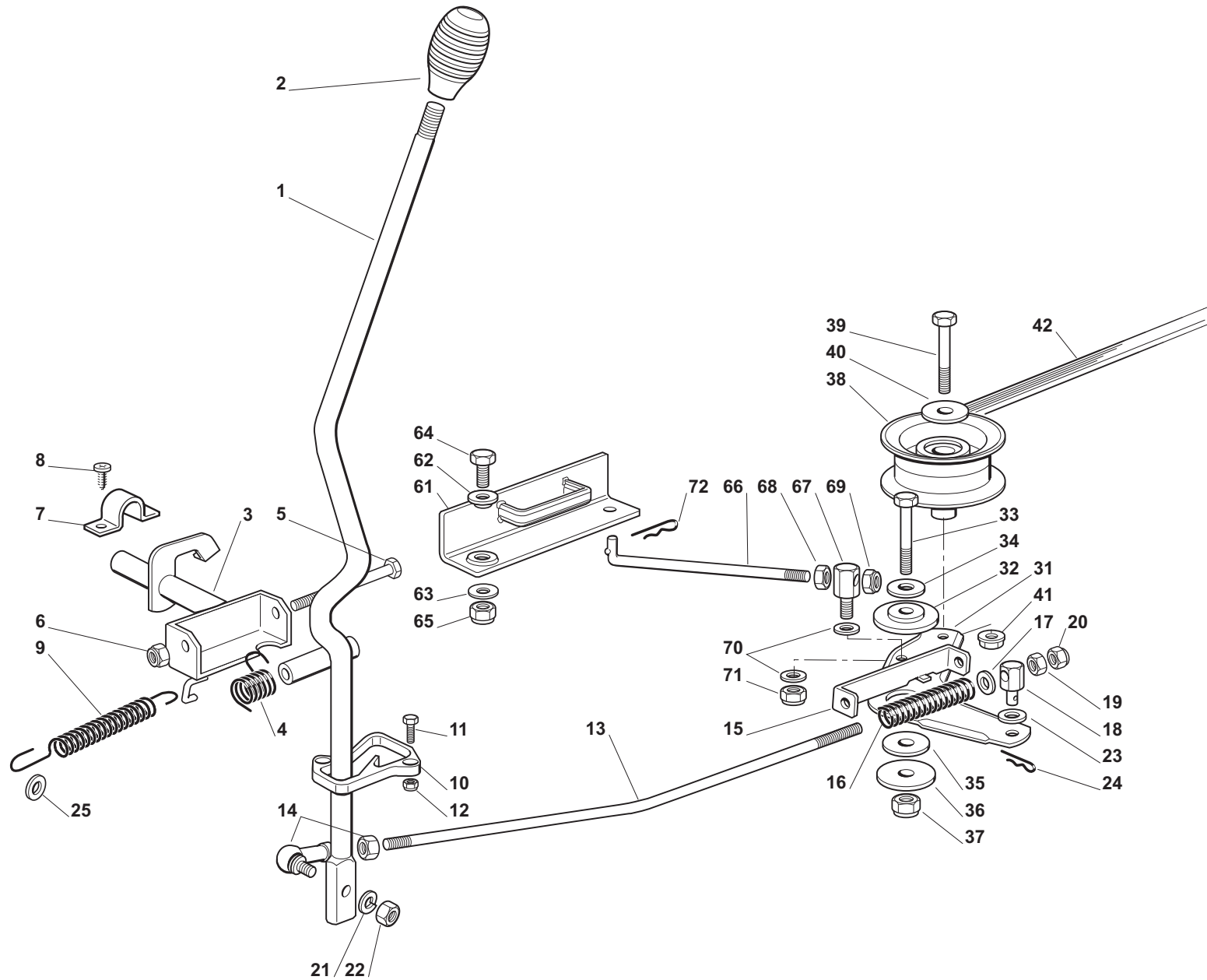

(2008): RM-72.13 H

8

SCHNEIDWERKZEUG (1)
 CUTTING PLATE (1)
 PLATEAU DE COUPE (1)
 HERRAMIENTA DE CORTE (1)

DOLMARA member of the **Takita** Group

Seite / Page	Pos.	RM-72.13 H	Teil-Nr. Part No. No. de pièce No. de pieza	Hinweise Notes Renseign. Nota	Bezeichnung	Spezifikation Specification	Description	Désignation	Denominación
8	1	1	664 317 069		HEBEL		LEVER	LEVIER	PALANCA
8	2	1	664 394 510		GRIFF		KNOB	POIGNEE	MANETA
8	3	1	664 001 007		ACHSE		AXLE	AXE	EJE
8	4	1	664 430 226		FEDER		SPRING	RESSORT	MUELLE
8	5	1	664 692 050		SCHRAUBE		SCREW	VIS	TORNILLO
8	6	1	664 155 000		MUTTER		NUT	ECROU	TUERCA
8	7	2	664 547 049		PLATTE		PLATE	PLAQUE	PLACA
8	8	4	664 731 601		SCHRAUBE		SCREW	VIS	TORNILLO
8	9	1	664 430 571		FEDER		SPRING	RESSORT	MUELLE
8	10	1	664 487 000		GLEITBLOCK		SHOE	BLOC DE GLISSEMENT	BLOQUE DESLIZANTE
8	11	2	664 791 200		SCHRAUBE		SCREW	VIS	TORNILLO
8	12	2	664 154 510		MUTTER		NUT	ECROU	TUERCA
8	13	1	664 034 078		STAB		ROD	TIGE	VARILLA
8	14	1	664 746 601		GELENK		JOINT	JOINT	ARTICULACIÓN
8	15	1	664 772 143		KLAMMER FEDERDÄMPFER		CLAMP	ETRIER	GRAPA
8	16	1	664 430 576		FEDER		SPRING	RESSORT	MUELLE
8	17	1	664 521 350		SCHEIBE		WASHER	RONDELLE	ARANDELA
8	18	1	664 510 113		BOLZEN		PIN	PIVOT	PIVOTE
8	19	1	664 293 200		MUTTER		NUT	ECROU	TUERCA
8	20	1	664 155 000		MUTTER		NUT	ECROU	TUERCA
8	21	1	664 583 500		FEDERRING		GROWER	GROWER	ARANDELA ELÁSTICA
8	22	1	664 293 200		MUTTER		NUT	ECROU	TUERCA
8	23	1	664 670 008		SCHEIBE		WASHER	RONDELLE	ARANDELA
8	24	1	664 487 997		SPLINT		COTTER PIN	GOUVILLE	PASADOR
8	25	1	664 670 006		SCHEIBE		WASHER	RONDELLE	ARANDELA
8	31	1	664 317 083		HEBEL		LEVER	LEVIER	PALANCA
8	32	1	664 047 000		BUCHSE		BUSH	DOUILLE	CASQUILLO
8	33	1	664 691 200		SCHRAUBE		SCREW	VIS	TORNILLO
8	34	1	664 523 060		SCHEIBE		WASHER	RONDELLE	ARANDELA
8	35	1	664 672 152		SCHEIBE		WASHER	RONDELLE	ARANDELA
8	36	1	664 523 070		SCHEIBE		WASHER	RONDELLE	ARANDELA
8	37	1	664 155 000		MUTTER		NUT	ECROU	TUERCA
8	38	1	664 604 008		RIEMENSCHLEIBE		PULLEY	POULIE	POLEA
8	39	1	664 691 600		SCHRAUBE		SCREW	VIS	TORNILLO
8	40	1	664 523 060		SCHEIBE		WASHER	RONDELLE	ARANDELA
8	41	1	664 293 201		MUTTER		NUT	ECROU	TUERCA
8	42	1	664 061 423		RIEMEN		BELT	COURROIE	CORREA
8	61	1	664 220 501		BREMSE		BRAKE	FREIN	FRENO
8	62	1	664 041 980		BUCHSE		BUSH	DOUILLE	CASQUILLO
8	63	1	664 672 152		SCHEIBE		WASHER	RONDELLE	ARANDELA
8	64	1	664 793 102		SCHRAUBE		SCREW	VIS	TORNILLO
8	65	1	664 155 010		MUTTER		NUT	ECROU	TUERCA
8	66	1	664 034 077		STAB		ROD	TIGE	VARILLA

(2008): RM-72.13 H

8

SCHNEIDWERKZEUG (1)
CUTTING PLATE (1)
PLATEAU DE COUPE (1)
HERRAMIENTA DE CORTE (1)

DOLMAR
A member of the *Takita* Group

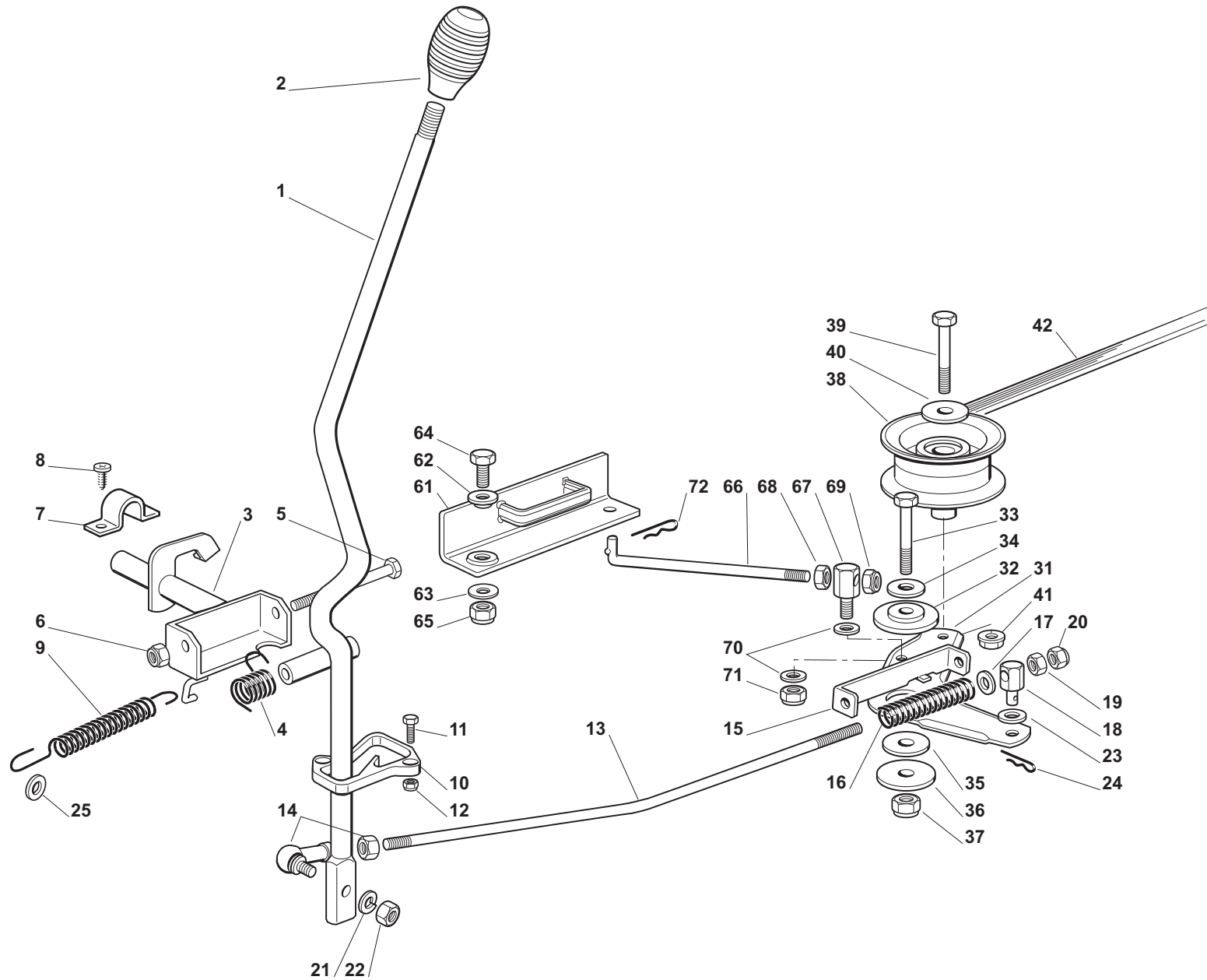

(2008): RM-72.13 H

8

SCHNEIDWERKZEUG (1)
CUTTING PLATE (1)
PLATEAU DE COUPE (1)
HERRAMIENTA DE CORTE (1)

DOLMAR



A member of the **Takita** Group

Seite / Page	Pos.	RM-72.13 H	Teil-Nr. Part No. No. de pièce No. de pieza	Hinweise Notes Renseign. Nota	Bezeichnung	Spezifikation Specification	Description	Désignation	Denominación
8	67	1	664 510 040		BOLZEN		PIN	PIVOT	PIVOTE
8	68	1	664 293 200		MUTTER		NUT	ECROU	TUERCA
8	69	1	664 155 000		MUTTER		NUT	ECROU	TUERCA
8	70	2	664 670 011		SCHEIBE		WASHER	RONDELLE	ARANDELA
8	71	1	664 155 000		MUTTER		NUT	ECROU	TUERCA
8	72	1	664 487 997		SPLINT		COTTER PIN	GOUPILLE	PASADOR

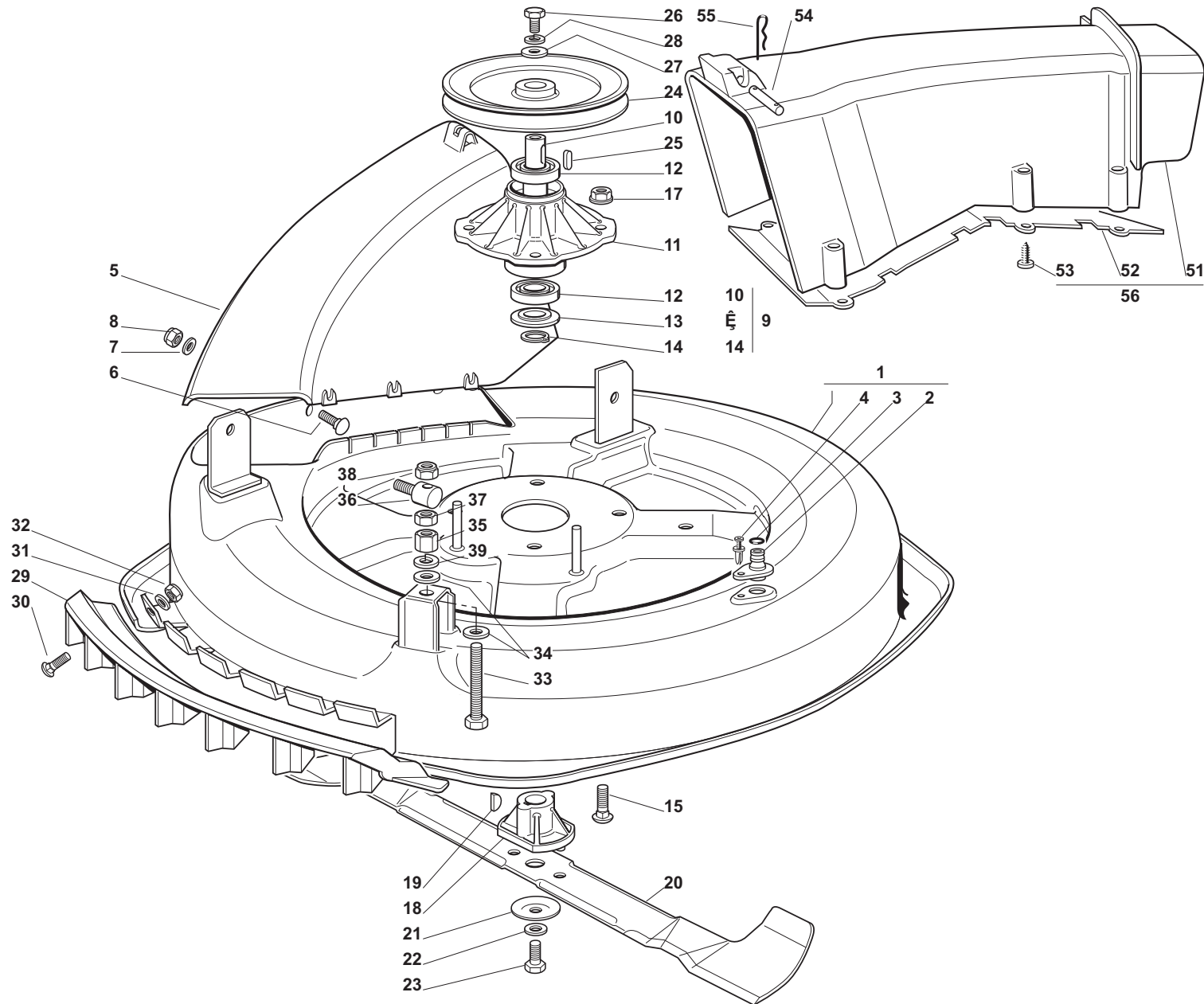

(2008): RM-72.13 H

9

SCHNEIDWERKZEUG (2)
CUTTING PLATE (2)
PLATEAU DE COUPE (2)
HERRAMIENTA DE CORTE (2)

DOLMAR
A member of the **Takita** Group

Seite / Page	Pos.	RM-72.13 H	Teil-Nr. Part No. No. de pièce No. de pieza	Hinweise Notes Renseign. Nota	Bezeichnung	Spezifikation Specification	Description	Désignation	Denominación
9	1	1	664 564 097		MESSERTROMMEL		PLATE	PLATEAU	PLANCHA
9	2	1	664 033 060		WASSERANSCHLUSS		WATER HOSE CONNECTION	RACCORD TUYAU D'EAU	TOMA DE AGUA
9	3	1	664 035 000		O-RING		O-RING	O-RING	JUNTA TÓRICA
9	4	1	664 500 030		NIET		RIVET	RIVET	REMACHE
9	5	1	664 045 000		BLECHSATZEINGANG		CONVEYOR INLET	BOUCHE CONVOYEUR	CHAPA DE GUÍA
9	6	6	664 815 210		SCHRAUBE		SCREW	VIS	TORNILLO
9	7	6	664 523 040		SCHEIBE		WASHER	RONDELLE	ARANDELA
9	8	6	664 154 510		MUTTER		NUT	ECROU	TUERCA
9	9	1	664 207 250		NABE, KPL.		FLANGE ASSY.	ENS. BRIDE	BRIDA CPL.
9	10	1	664 023 000		WELLE		SHAFT	ARBRE	ÁRBOL
9	11	1	664 208 402		FLANSCH		FLANGE	BRIDE	BRIDA
9	12	2	664 216 032		KUGELLAGER		BEARING	ROULEMENT	RODAMIENTO A BOLAS
9	13	1	664 160 501		STAUBSCHUTZSCHEIBE		DUST COVER	PROTEGE-POUSSIÈRE	CUBIERTA GUARDAPOLVO
9	14	1	664 609 260		SICHERUNGSRING		RETAINING RING	ANNEAU DE SÛRETÉ	ANILLO DE SEGURIDAD
9	15	4	664 818 700		SCHRAUBE		SCREW	VIS	TORNILLO
9	17	4	664 154 210		MUTTER		NUT	ECROU	TUERCA
9	18	1	664 463 200		MESSERHALTER		BLADE HUB	MOYEU LAME	SOPORTE DE LA CUCHILLA
9	19	1	664 139 100		KEIL		KEY	CLAVETTE	CHAVETA
9	20	1	664 109 502		FANGMESSER		BLADE (COLLECT)	LAME	CUCHILLA ESTÁNDAR
9	21	1	664 160 400		FEDERSCHEIBE		ELASTIC WASHER	RONDELLE ELASTIQUE	ARANDELA ELÁSTICA
9	22	1	664 523 080		SCHEIBE		WASHER	RONDELLE	ARANDELA
9	23	1	664 735 694		SCHRAUBE		SCREW	VIS	TORNILLO
9	24	1	664 604 009		RIEMENSCHLEIBE		PULLEY	POULIE	POLEA
9	25	1	664 139 480		KEIL		KEY	CLAVETTE	CHAVETA
9	26	1	664 793 102		SCHRAUBE		SCREW	VIS	TORNILLO
9	27	1	664 670 007		SCHEIBE		WASHER	RONDELLE	ARANDELA
9	28	1	664 583 500		FEDERRING		GROWER	GROWER	ARANDELA ELÁSTICA
9	29	1	664 488 000		ANSAUGGITTER		AIR INTAKE GRILL	GRILLE D'ASPIRATION	PARRILLA DE ASPIRACIÓN
9	30	4	664 815 200		SCHRAUBE		SCREW	VIS	TORNILLO
9	31	4	664 521 340		SCHEIBE		WASHER	RONDELLE	ARANDELA
9	32	4	664 154 510		MUTTER		NUT	ECROU	TUERCA
9	33	1	664 794 970		SCHRAUBE		SCREW	VIS	TORNILLO
9	34	2	664 523 080		SCHEIBE		WASHER	RONDELLE	ARANDELA
9	35	1	664 154 250		MUTTER		NUT	ECROU	TUERCA
9	36	1	664 510 007		BOLZEN		PIN	PIVOT	PIVOTE
9	37	1	664 295 200		MUTTER		NUT	ECROU	TUERCA
9	38	1	664 156 602		MUTTER		NUT	ECROU	TUERCA
9	39	1	664 585 100		FEDERRING		GROWER	GROWER	ARANDELA ELÁSTICA
9	51	1	664 107 501		BLECHSATZ		CONVEYOR	CONVOYEUR	JUEGO DE CHAPA
9	52	1	664 140 051		ABWEISER		DEFLECTOR	DEFLECTEUR	DEFLECTOR
9	53	8	664 735 402		SCHRAUBE		SCREW	VIS	TORNILLO
9	54	1	664 510 097		BOLZEN		PIN	PIVOT	PIVOTE
9	55	2	664 487 997		SPLINT		COTTER PIN	GOUPILLE	PASADOR

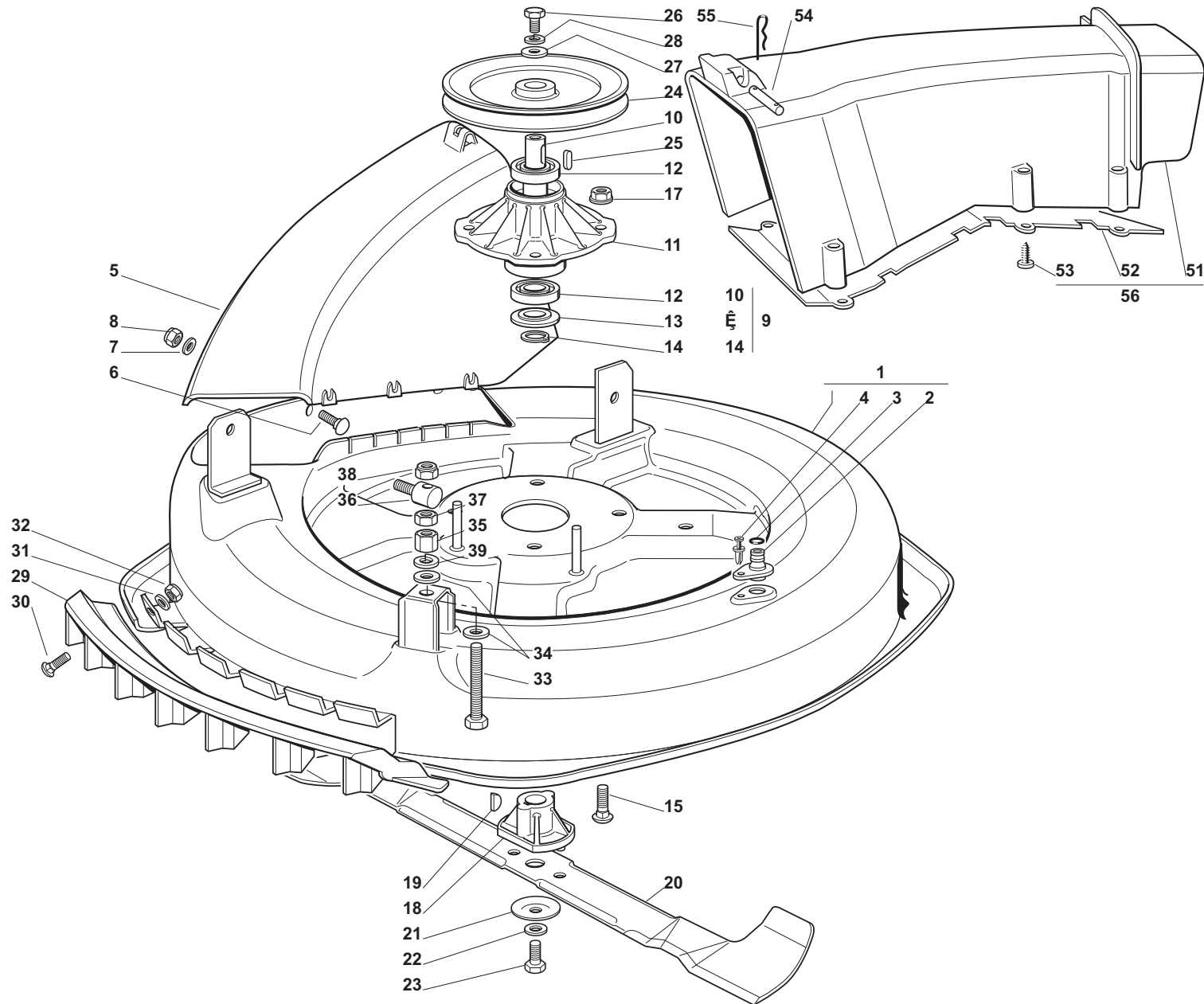

(2008): RM-72.13 H

9

SCHNEIDWERKZEUG (2)
CUTTING PLATE (2)
PLATEAU DE COUPE (2)
HERRAMIENTA DE CORTE (2)

DOLMAR



A member of the **Makita** Group

Seite / Page	Pos.	RM-72.13 H	Teil-Nr. Part No. No. de pièce No. de pieza	Hinweise Notes Renseign. Nota	Bezeichnung	Spezifikation Specification	Description	Désignation	Denominación
9	56	1	664 108 051		BLECHSATZ KPL.		CONVEYOR ASSY.	ENS. CONVOYEUR	JUEGO DE CHAPA, CPL.

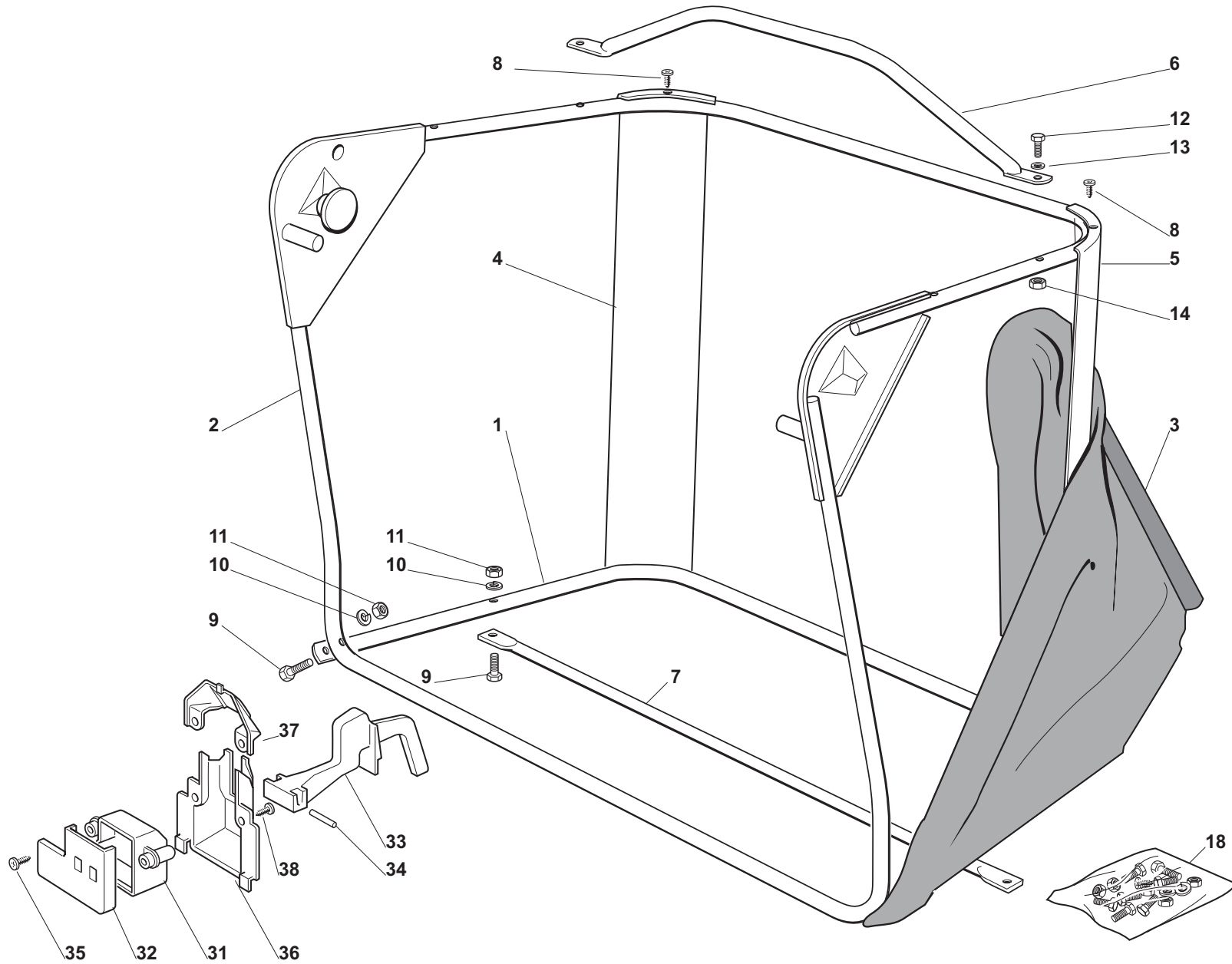

(2008): RM-72.13 H

10

GRASS-SACK
GRASSCATCHER
BAC
CESTO**DOLMAR**A member of the **Takita** Group

Seite / Page	Pos.	RM-72.13 H	Teil-Nr. Part No. No. de pièce No. de pieza	Hinweise Notes Renseign. Nota	Bezeichnung	Spezifikation Specification	Description	Désignation	Denominación
10	1	1	664 801 103		UNTERERRAHMEN		LOWER FRAME	CHASSIS INFÉRIEUR	CHASIS INFERIOR
10	2	1	664 801 105		OBERERRAHMEN		UPPER FRAME	CHASSIS SUPÉRIEUR	CHASIS SUPERIOR
10	3	1	664 106 050		GRASS-SACK		GRASSCATCHER	BAC	CESTO
10	4	1	664 010 205		HALTER RECHTS		SUPPORT RIGHT	SUPPORT DROITE	SOPORTE DER.
10	5	1	664 010 207		HALTER LINKS		SUPPORT LEFT	SUPPORT GAUCHE	SOPORTE IZQ.
10	6	1	664 869 051		STANGE		ROD	BARRE	BARRA
10	7	1	664 650 100		VERSTÄRKUNG		STIFFENING	REINFORCEMENT	REFUERZO INFERIOR
10	8	4	664 729 601		SCHRAUBE		SCREW	VIS	TORNILLO
10	9	4	664 792 099		SCHRAUBE		SCREW	VIS	TORNILLO
10	10	4	664 582 101		FEDERRING		GROWER	GROWER	ARANDELA ELÁSTICA
10	11	4	664 292 100		MUTTER		NUT	ECROU	TUERCA
10	12	2	664 674 701		SCHRAUBE		SCREW	VIS	TORNILLO
10	13	2	664 521 331		SCHEIBE		WASHER	RONDELLE	ARANDELA
10	14	2	664 154 510		MUTTER		NUT	ECROU	TUERCA
10	18	1	664 180 180		SCHRAUBENAUSRÜSTUNG		SCREWS OUTFIT	ENSEMBLE DES VIS	JUEGO DE TORNILLOS
10	31	1	664 600 041		SCHUTZ		PROTECTION	PROTECTION	PROTECCIÓN
10	32	1	664 600 042		SCHUTZDECKEL		PROTECTION COVER	COUVERCLE PROTECTION	CUBIERTA PROTECTORA
10	33	1	664 318 124		HEBEL		LEVER	LEVIER	PALANCA
10	34	1	664 400 030		BOLZEN		PIN	PIVOT	PIVOTE
10	35	1	664 728 510		SCHRAUBE		SCREW	VIS	TORNILLO
10	36	1	664 600 047		SCHUTZ		PROTECTION	PROTECTION	PROTECCIÓN
10	37	1	664 600 048		ABWEISERDECKEL		DEFLECTOR COVER	COUVERCLE DEFLECTEUR	CUBIERTA DEL DEFLECTOR
10	38	2	664 728 450		SCHRAUBE		SCREW	VIS	TORNILLO

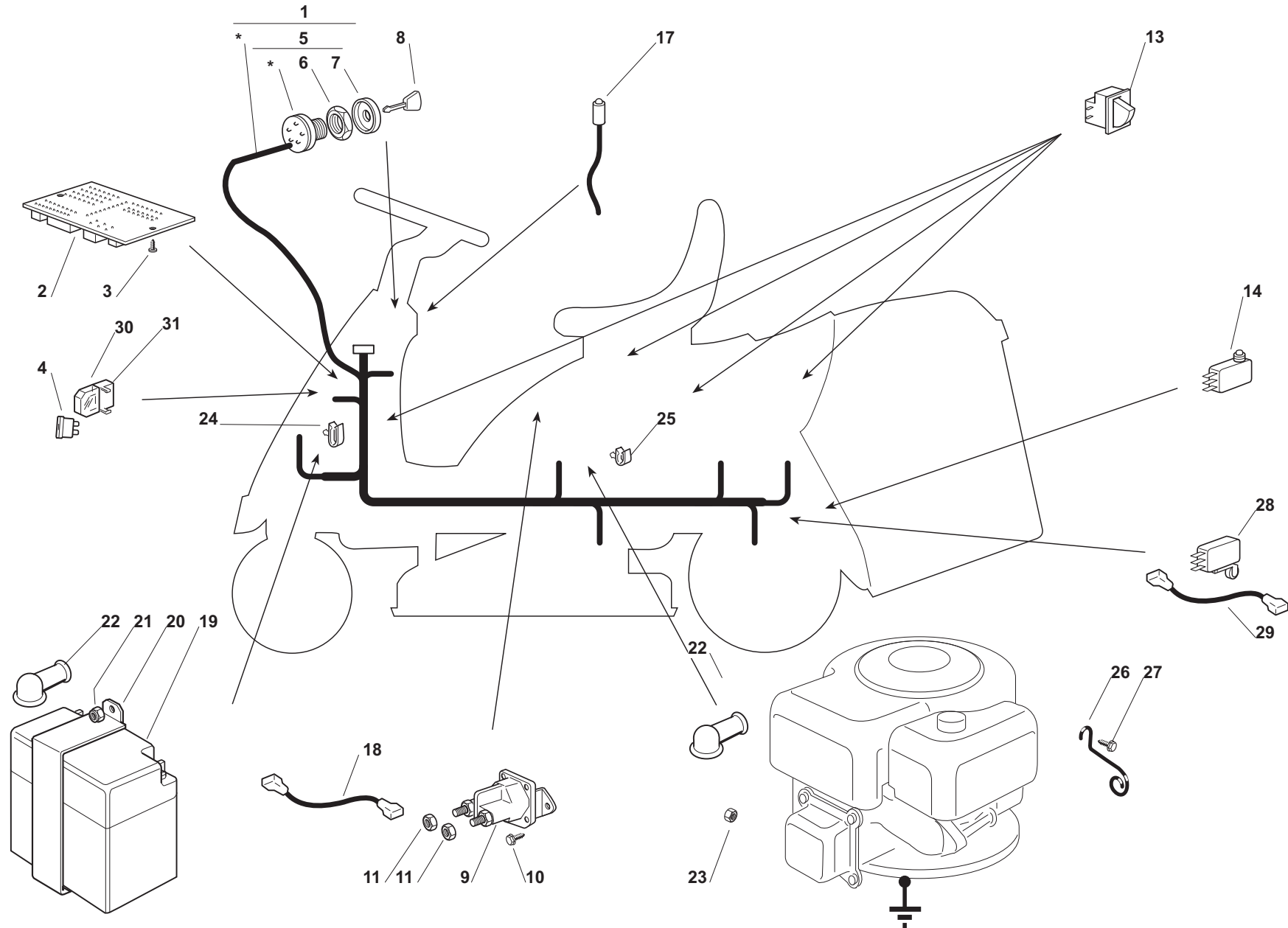

(2008): RM-72.13 H

11

ELEKTRISCHE TEILE
ELECTRICAL PARTS
PIECES ELECTRIQUES
PARTES ELÉCTRICAS**DOLMAR**A member of the **Takita** Group

Seite / Page	Pos.	RM-72.13 H	Teil-Nr. Part No. No. de pièce No. de pieza	Hinweise Notes Renseign. Nota	Bezeichnung	Spezifikation Specification	Description	Désignation	Denominación
11	*	x			ZUM AUSTAUSCH DER MIT «*» GEKENNZEICHNETEN TEILE, WENDEN SIE SICH AN DEN KUNDENDIENST DES MOTORHERSTELLERS.		TO REPLACE THE PARTS MARKED «*» SEEK ASSISTANCE FROM THE ENGINE MANUFACTURER'S AFTER SALES SERVICE.	POUR LE REMPLACEMENT DES PIÈCES MARQUÉES AVEC «*» S'ADRESSER AU SERVICE APRÈS VENTES DU CONSTRUCTEUR DU MOTEUR.	PARA RECAMBIO DE LAS PIEZAS MARCADO CON <<*>> FAVOR SE DIRIGEN AL SERVICIO TÉCNICO DEL FABRICANTE DEL MOTOR.
11	1	1	664 999 008		KABELSATZ		SET OF WIRES	JEU DE CÂBLES	JUEGO DE CABLES
11	2	1	664 722 415		ELEKTRONISCHE KARTE		ELECTRONIC CARD	CARTE ELECTRONIQUE	TARJETA ELECTRÓNICA
11	3	2	664 727 810		SCHRAUBE		SCREW	VIS	TORNILLO
11	4	1	664 340 040		SICHERUNG		FUSE	FUSIBLE	FUSIBLE
11	4	1	664 340 036		SICHERUNG		FUSE	FUSIBLE	FUSIBLE
11	5	1	664 450 065		SCHALTER		STARTING SWITCH	INTERRUPTEUR DEMARRAGE	INTERRUPTOR DE ENCENDIDO
11	6	1	664 400 861		NUTMUTTER		RING NUT	EMBOUT	TUERCA RANURADA
11	7	1	664 565 351		NUTMUTTER SCHUTZ		SCREWED RING PROTECTION	PROTECTION EMBOUT	PROTECCIÓN TUERCA RANURADA
11	8	1	664 210 016		SCHLÜSSEL FÜR START		STARTING KEY	CLEF A DEMARRAGE	LLAVE DE ENCENDIDO
11	9	1	664 736 110		ANLASSRELAIS		STARTER RELAY	RELAIS D'ALLUMAGE	RELÉ DE ARRANQUE
11	10	2	664 735 110		SCHRAUBE		SCREW	VIS	TORNILLO
11	11	2	664 360 352		MUTTER		NUT	ECROU	TUERCA
11	13	4	664 410 606		MIKROSCHALTER		MICROSWITCH	MICROINTERRUPTEUR	MICROINTERRUPTOR
11	14	1	664 410 605		FÜLLHÖHENSCHALTER		FULL GRASSCATC. MICRO	MICRO BAC PLEIN	MICRO. CESTO LLENO
11	17	1	664 065 014		KABEL		CABLE	CABLES	CABLE
11	18	1	664 065 050		KABEL		CABLE	CABLES	CABLE
11	19	1	664 120 002		BATTERIE		BATTERY	BATTERIE	BATERÍA
11	20	1	664 772 099		BATTERIEHALTER		CLAMP	ETRIER	SOPORTE DE BATERÍA
11	21	1	664 155 000		MUTTER		NUT	ECROU	TUERCA
11	22	2	664 564 861		STECKER		PROTECTION	CAPUCHON	CAPUCHÓN
11	23	1	664 361 005		MUTTER		NUT	ECROU	TUERCA
11	24	3	664 320 506		KABELBEFESTIGUNG		FAIRLEAD	FIXATION CABLE	SUJETACABLE
11	25	1	664 320 504		KABELBEFESTIGUNG		FAIRLEAD	FIXATION CABLE	SUJETACABLE
11	26	1	664 430 561		FEDER		SPRING	RESSORT	MUELLE
11	27	1	664 735 121		SCHRAUBE		SCREW	VIS	TORNILLO
11	28	1	664 410 609		MIKROSCHALTER LEERLAUF		SWITCH	INTERRUPTEUR	INTERRUPTOR
11	29	1	664 065 025		KABEL		CABLE	CÂBLE	CABLE
11	30	2	664 215 000		DECKEL		COVER	COUVERCLE	CUBIERTA
11	31	2	664 500 007		SICHERUNGHALTER		FUSE CARRIER	TABLEAU DE FUSIBLE	SOPORTE

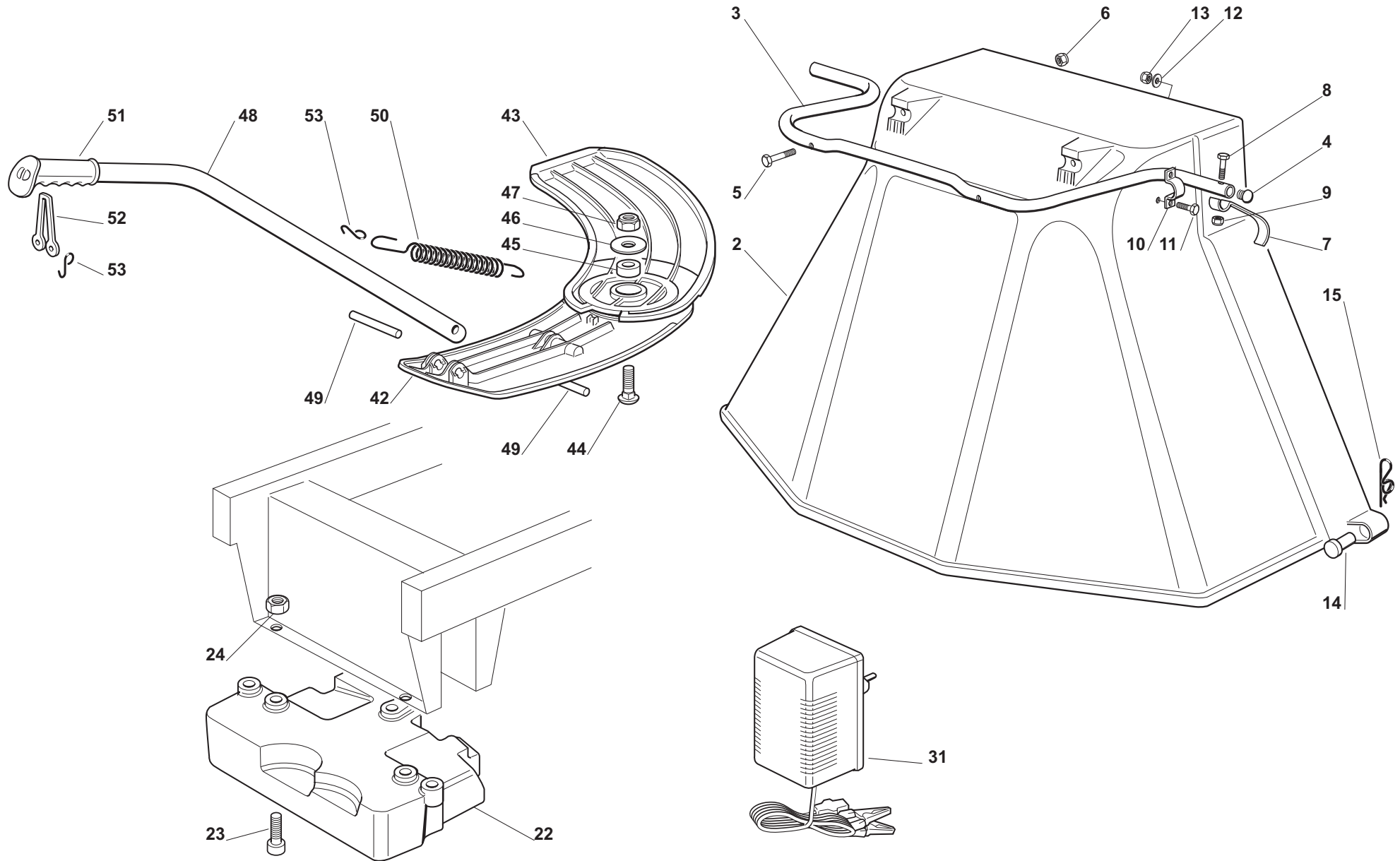

(2008): RM-72.13 H

12

ZUBEHÖR NACH ANFRAGE
 OPTIONALS ON REQUEST
 ACCESSOIRES SUR DEMANDE
 ACCESORIO BAJO DEMANDA

DOLMARA member of the **Takita** Group

Seite / Page	Pos.	RM-72.13 H	Teil-Nr. Part No. No. de pièce No. de pieza	Hinweise Notes Renseign. Nota	Bezeichnung	Spezifikation Specification	Description	Désignation	Denominación
12	2	1	664 598 062		AUSWURFSCHUTZ		EJECTION GUARD	PROTECTION SORTIE	PROTECCIÓN DE SALIDA
12	3	1	664 869 053		HALTER		SUPPORT	SUPPORT	SOPORTE
12	4	2	664 566 113		PFROPFEN		CAP	BOUCHON	TAPÓN
12	5	2	664 674 701		SCHRAUBE		SCREW	VIS	TORNILLO
12	6	2	664 154 510		MUTTER		NUT	ECROU	TUERCA
12	7	1	664 547 053		PLÄTTCHEN		PLATE	PLAQUETTE	PLAQUITA
12	8	1	664 791 500		SCHRAUBE		SCREW	VIS	TORNILLO
12	9	1	664 154 510		MUTTER		NUT	ECROU	TUERCA
12	10	2	664 547 049		PLATTE		PLATE	PLAQUE	PLACA
12	11	4	664 788 910		SCHRAUBE		SCREW	VIS	TORNILLO
12	12	4	664 523 020		SCHEIBE		WASHER	RONDELLE	ARANDELA
12	13	4	664 154 320		MUTTER		NUT	ECROU	TUERCA
12	14	2	664 510 022		BOLZEN		PIN	PIVOT	PIVOTE
12	15	2	664 487 997		SPLINT		COTTER PIN	GOUPILLE	PASADOR
12	22	1	664 519 997		GEWICHT		WEIGHT	POIDS	PESO
12	23	3	664 760 520		SCHRAUBE		SCREW	VIS	TORNILLO
12	24	3	664 155 000		MUTTER		NUT	ECROU	TUERCA
12	31	1	664 180 050		BATTERIELADEGERÄT		BATTERY CHARGER	CHARGEUR DE BATTERIES	CARGADOR DE BATERÍAS
12	31	1	664 180 052		BATTERIELADEGERÄT		BATTERY CHARGER	CHARGEUR DE BATTERIES	CARGADOR DE BATERÍAS
12	42	1	664 140 055		ABWEISER, HINTER		DEFLECTOR, REAR	DEFLECTEUR, ARRIERE	DEFLECTOR, DETRÁS
12	43	1	664 140 054		ABWEISER, VORDER		DEFLECTOR, FRONT	DEFLECTEUR, AVANT	DEFLECTOR, DELANTE
12	44	1	664 818 700		SCHRAUBE		SCREW	VIS	TORNILLO
12	45	1	664 047 013		LAGER		BEARING	COUSSINET	RODAMIENTO
12	46	1	664 672 152		SCHEIBE		WASHER	RONDELLE	ARANDELA
12	47	1	664 155 000		MUTTER		NUT	ECROU	TUERCA
12	48	1	664 394 003		STIEL		HANDLE	GUIDON	MANGO
12	49	2	664 510 116		BOLZEN		PIN	PIVOT	PIVOTE
12	50	1	664 430 229		FEDER		SPRING	RESSORT	MUELLE
12	51	1	664 280 000		GRIFF		HANDGRIP	BRANCHE	MANETA
12	52	1	664 840 011		GUMMIZUG		ELASTIC TIE-ROD	TIRANT ELASTIQUE	TENSOR DE GOMA
12	53	3	664 253 004		HAKEN		HOOK	CROCHET	GANCHO

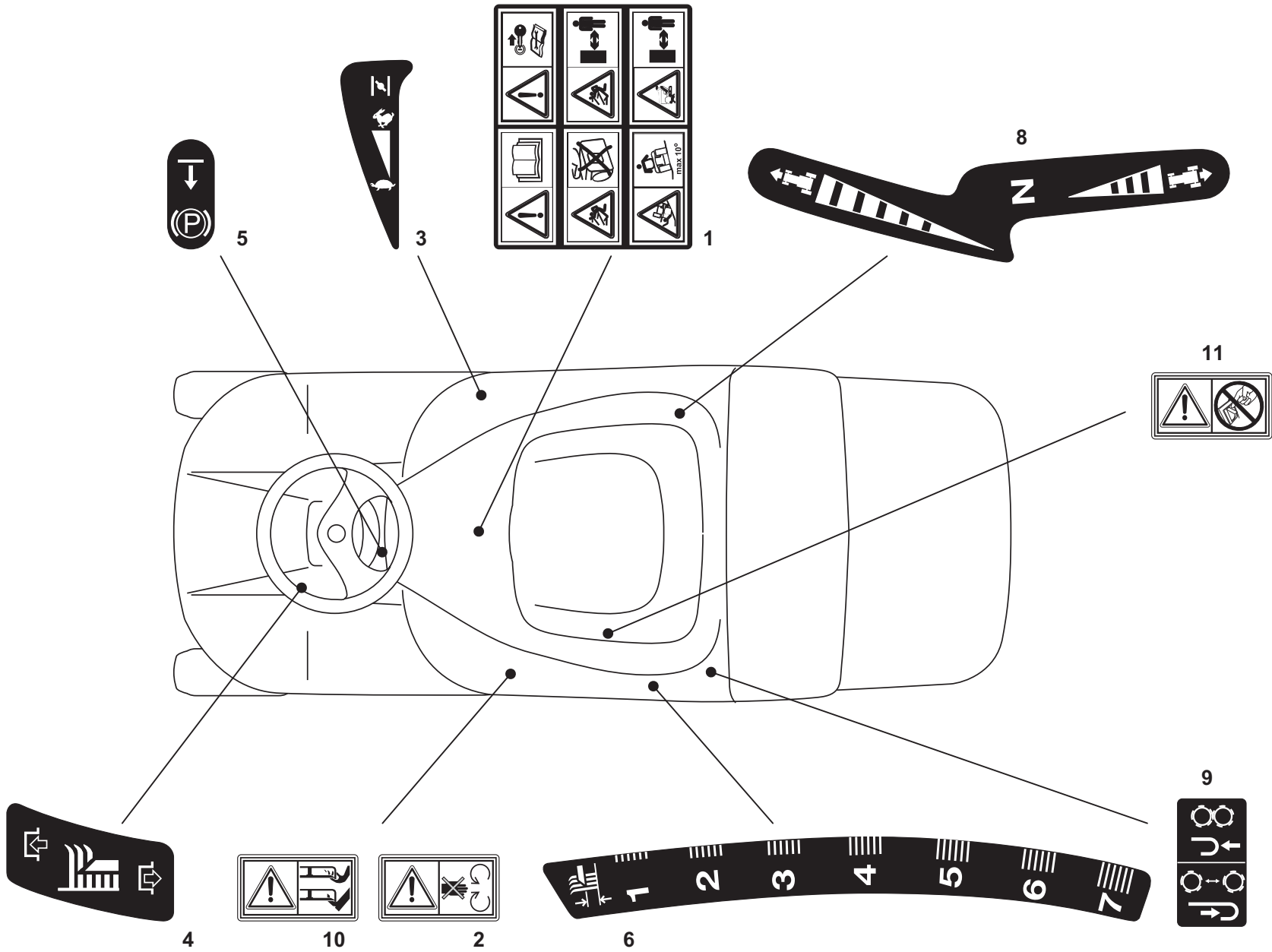

(2008): RM-72.13 H

13

AUFKLEBER
LABELS
ETIQUETTES
ETIQUETA

DOLMAR



A member of the **Takita** Group

Seite / Page	Pos.	RM-72.13 H	Teil-Nr. Part No. No. de pièce No. de pieza	Hinweise Notes Renseign. Nota	Bezeichnung	Spezifikation Specification	Description	Désignation	Denominación
13	1	1	664 357 428		SCHILD		LABEL	ETIQUETTE	ETIQUETA
13	2	1	664 999 519		SCHILD		LABEL	ETIQUETTE	ETIQUETA
13	3	1	664 999 425		SCHILD		LABEL	ETIQUETTE	ETIQUETA
13	4	1	664 357 431		SCHILD		LABEL	ETIQUETTE	ETIQUETA
13	5	1	664 999 526		SCHILD		LABEL	ETIQUETTE	ETIQUETA
13	6	1	664 357 427		SCHILD		LABEL	ETIQUETTE	ETIQUETA
13	8	1	664 357 702		SCHILD		LABEL	ETIQUETTE	ETIQUETA
13	9	1	664 358 513		SCHILD		LABEL	ETIQUETTE	ETIQUETA
13	10	2	664 356 699		SCHILD		LABEL	ETIQUETTE	ETIQUETA
13	11	1	664 360 118		SCHILD		LABEL	ETIQUETTE	ETIQUETA

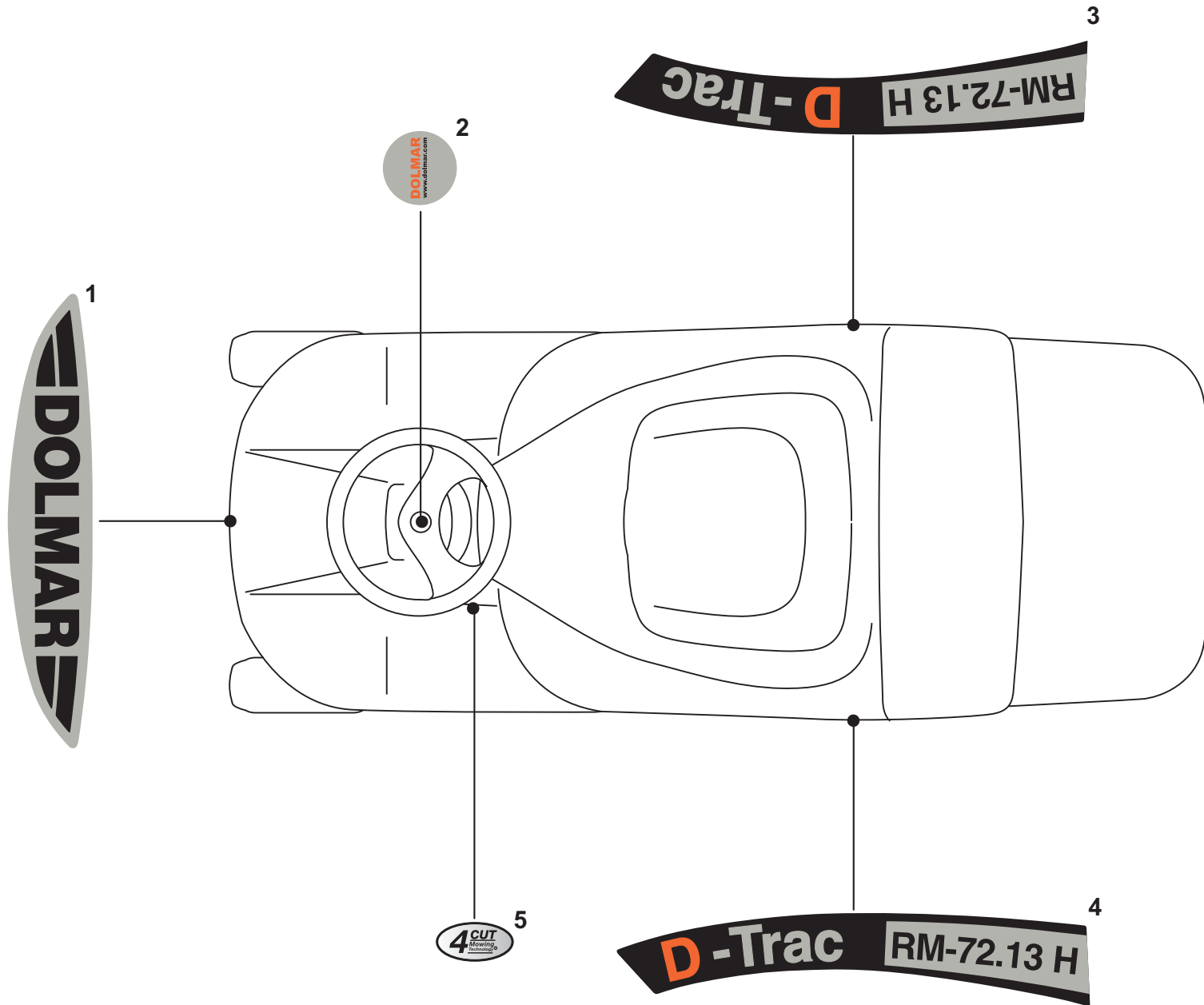

(2008): RM-72.13 H

14

AUFKLEBER
LABELS
ETIQUETTES
ETIQUETA

DOLMAR



A member of the **Makita** Group

Seite / Page	Pos.	RM-72.13 H	Teil-Nr. Part No. No. de pièce No. de pieza	Hinweise Notes Renseign. Nota	Bezeichnung	Spezifikation Specification	Description	Désignation	Denominación
14	1	1	664 362 505		SCHILD		LABEL	ETIQUETTE	ETIQUETA
14	2	1	664 361 485		SCHILD		LABEL	ETIQUETTE	ETIQUETA
14	3	1	664 362 506		SCHILD		LABEL	ETIQUETTE	ETIQUETA
14	4	1	664 362 507		SCHILD		LABEL	ETIQUETTE	ETIQUETA
14	5	1	664 361 576		SCHILD		LABEL	ETIQUETTE	ETIQUETA

(2008): RM-72.13 H

DOLMAR



A member of the **Takita** Group

	Zeichenerklärung	Key to symbols	Légende	Explicación de símbolos
=> 1999999 2000000 => 2003.04 => TI 2003/07 Acc. = { m Corr.	Produktion bis Serien-Nr. Neues Teil ab Serien-Nr. Neues Teil ab Jahr / Monat Siehe Technische Information Jahr / Nr. Zubehör (nicht im Lieferumfang) Keine Serienausführung, jedoch verwendbar Beinhaltet Positions-Nr. Meterware Druckfehlerberichtigung	Production to serial number New part from serial number New part from Year / Month See Technical Information Year / No. Accessories (not included in the delivery inventory) No standard execution, may be used Contains item number Sold by the meter Error correction	Production jusqu'à n° de série Nouveau pièce à partir du n° de série Nouveau pièce à partir de année / mois Voir information technique année / n° Accessoires (non compris dans la livraison) Aucune exécut. en série, cependant utilisable contient n° de numéro Au mètre Rectification d'erreurs	Producción hasta N° de serie Pieza nueva a partir de N° de serie Pieza nueva a partir de año / mes Véase inform. técnico año / N° Accesorios (no incluido en la extensión del suministro) No es de serie, pero sirve Contiene pos N° Por metro Fe de erratas
	Änderungen vorbehalten	Specifications subject to change without notice	Changements sans préavis	Mejoras constructivas sin previo aviso