

Pos.	*PG	Bestell-Nr.	Bezeichnung	Pos.	*PG	Bestell-Nr.	Bezeichnung
001	14	322566-3	DICHTUNG	051	26	212358-7	NADELLAGER 2520
002	21	211256-2	RILLENKUGELLAGER 6203LLB	052	39	322476-4	PLEUELSTANGE
003	9	267706-5	ISOLIERSCHEIBE	053	3	213662-7	O-RING 55
004	67	516922-9	ANKER	054	44	324536-8	KOLBEN
005	18	681646-7	ISOLIERSCHEIBE	055	13	268130-5	STIFT 15
006	18	211066-7	RILLENKUGELLAGER 6200LLB	056	22	213666-9	O-RING 52
007	1	263002-9	GUMMISTIFT 4 [4]	057	74	331694-3	ZYLINDER 62
008	43	154586-7	MOTORGEHAEUSE B	058	22	213666-9	O-RING 52
009	26	191957-7	KOHLEBUERSTEN CB-204	059	49	324546-5	SCHLAEGER
010	7	643710-2	BUERSTENKAPPE	060			
011	32	317899-9	LAGERSCHILD	061			
012	3	265366-7	SCHRAUBE M6x22 [4]	062			
013	23	240024-6	LUEFTERRAD	063			
014	2	253165-9	UNTERLAGSCHEIBE 8	064			
015	2	931402-8	MUTTER M8	065	8	213855-6	O-RING 95
016	6	265344-7	SECHSKANTSCHR. M5x85 [2]	066	24	419001-1	DECKEL
017	51	628943-0	FELD	067	2	922331-6	INNENSECHSKANTSCHR. M6x20 [4]
018	30	414787-2	MOTORGEHAEUSE B	068			
019	2	254001-2	KEIL 4 [2]	069			
020	8	213507-9	O-RING 40	070			
021	3	256151-9	STIFT 5	071			
022	49	154585-9	GETRIEBEGEHAEUSEDECKEL	072			
023	20	211209-1	RILLENKUGELLAGER 6202	073			
024	46	226251-9	STIRNRAD KPL. 22	074			
025	2	254001-2	KEIL 4 [2]	075			
026	26	211361-5	RILLENKUGELLAGER 6305LLB	076			
027	19	213476-4	SIMMERRING 35	077			
028	8	213721-7	O-RING 61	078	3	256151-9	STIFT 5
029	9	213806-9	O-RING 90	079	17	324606-3	KAPPE
030	46	324544-9	KURBELWELLE	080	22	162241-7	DICHTUNG
031	78*	318027-9	GETRIEBEGEHAEUSE				
032	1	263002-9	GUMMISTIFT 4				
033	22	418955-9	GETRIEBEGEHAEUSEDECKEL A				
034	22	418953-3	GETRIEBEGEHAEUSEDECKEL B				
035	45	221793-8	STIRNRAD 50				
036	20	211209-1	RILLENKUGELLAGER 6202				
037	10	922496-4	INNENSECHSKANTSCHR. M8x75 [4]				
038	23	418415-1	SEITENGRIF				
039	1	922353-6	INNENSECHSKANTSCHR. M6x30 [4]				
040	45	317902-6	GETRIEBEGEHAEUSEABDECKUNG				
041	21	211214-8	RILLENKUGELLAGER 6302				
042	1	961060-6	SICHERUNGRING S-20				
043	49	226242-0	STIRNRAD 47				
044	16	331416-1	HUELSE 25				
045	13	962301-3	SICHERUNGRING 62				
046	2	922331-6	INNENSECHSKANTSCHR. M6x20 [4]				
047	1	941152-7	SCHEIBE 6 [4]				
048	34	183984-8	GEHAEUSEDECKEL				
049	14	267296-8	SCHEIBE 63				
050	28	324580-5	RING				

Zubehör
 - 783203-8 SECHSKANTSTIFTSCHLUESSEL 5mm

Ersatzteile
(nicht in der Explosionszeichnung vorhanden)
 zu Pos. 008:
 - 414665-6 HALTERING (PG 7)
 - 643711-0 KOHLEBUERSTENHALTER (PG 22)

Modell HM1801

Abbruchhammer

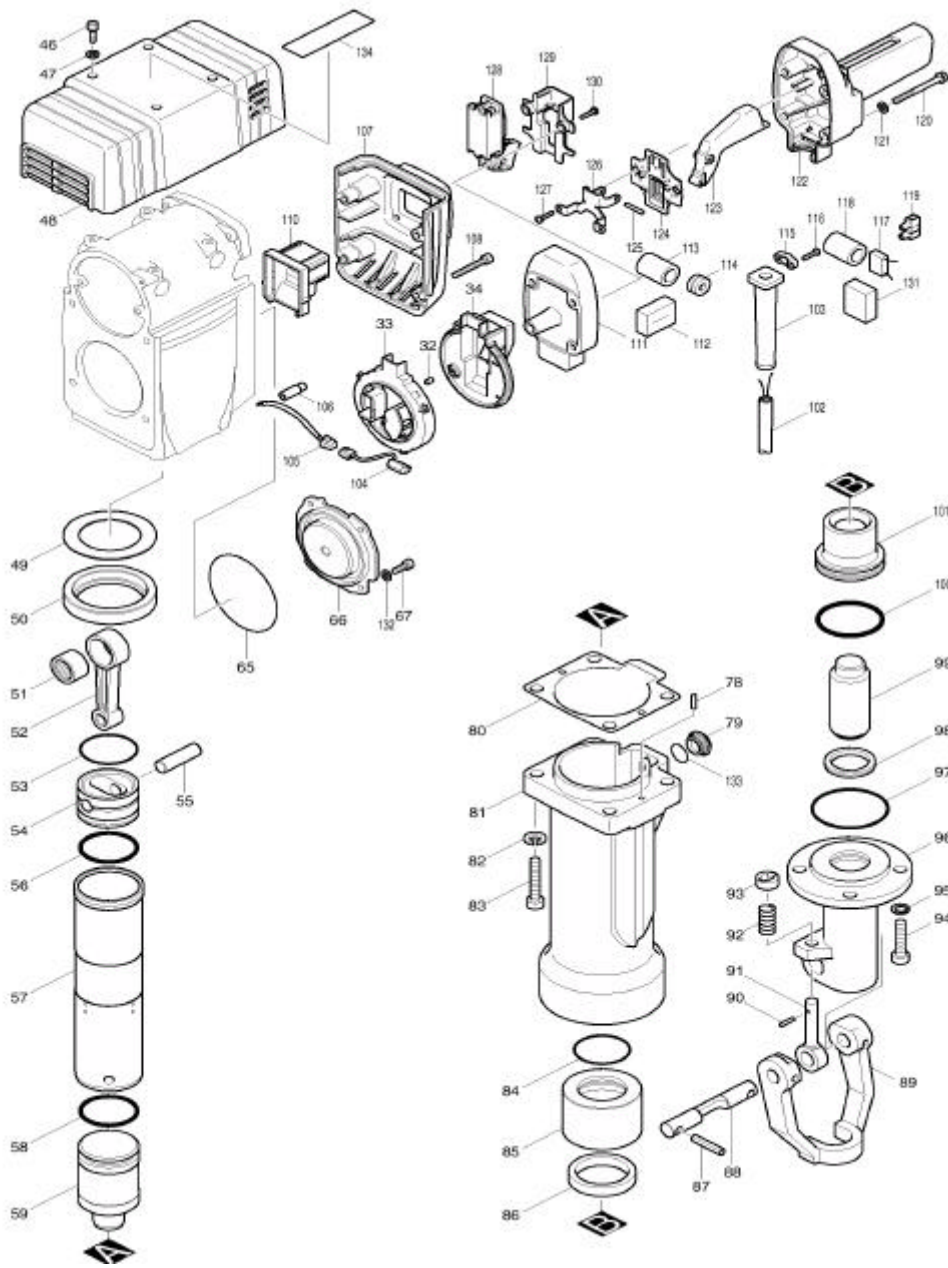

Pos.	*PG	Bestell-Nr.	Bezeichnung	Pos.	*PG	Bestell-Nr.	Bezeichnung
081	74	317917-3	ZYLINDER	131	2	685718-0	SCHAUMGUMMI
082	1	942301-9	FEDERRING 12 [4]	132	1	941152-7	SCHEIBE 6 [4]
083	8	922677-0	SCHRAUBE M12x55 [4]	133	2	213373-4	O-RING 22
084	5	213660-1	O-RING 53	134	12	819213-0	FIRMENSCHILD
085	51	322548-5	HUELSE				
086	16	262050-5	GUMMIRING 54 [2]				
087	4	951272-9	SPANNSTIFT 8-40				
088	31	324238-6	WERKZEUGHALTER				
089	71	324236-0	HALTEBUEGEL				
090	2	256219-1	STIFT 4 [2]				
091	35	322477-2	BUEGELHALTER [2]				
092	6	233083-7	DRUCKFEDER 13 [2]				
093	15	322560-5	HALTERING [2]				
094	9	265989-1	SCHRAUBE M12x45 [4]				
095	4	253989-3	SCHEIBE 12 [4]				
096	72	324539-2	WERKZEUGAUFNAHME				
097	7	213755-0	O-RING 75				
098	33	213517-6	X-RING 40				
099	31	324545-7	SCHLAGBOLZEN				
100	24	213667-7	O-RING 60				
101	44	324541-5	SCHLAGBOLZENFUEHRUNG				
102	25	P-26185	ANSCHLUSSLEITUNG				
103	12	682546-4	KNICKSCHUTZ 12-125				
104	20	631671-8	LAMPE				
105	11	638378-7	LAMPEN-ANSCHLUSSKABEL				
106	10	418951-7	LINSE				
107	40	317901-8	SEITENDECKEL				
108	3	922366-7	INNENSECHSKANTSCHR. M6x45 [4]				
109	5	861404-9	TYPENSCHILD				
110	14	418954-1	KABELFUEHRUNG				
111	20	419044-3	GRIFFPLATTE				
112	1	685700-9	SCHAUMGUMMI				
113	1	685722-9	SCHAUMSTOFFHUELSE				
114	2	688131-1	FILTER				
115	2	687053-2	KABELKLEMMPLATTE				
116	1	265995-6	SCHRAUBE 4x18 [2]				
117	10	645200-1	KONDENSATOR				
118	1	685722-9	SCHAUMSTOFFHUELSE				
119	14	654554-5	LUESTERKLEMME [2]				
120	3	265535-0	INNENSECHSKANTSCHR. M6x65 [4]				
121	1	941152-7	SCHEIBE 6 [4]				
122	30	418333-3	HANDGRIFF				
123	13	418332-5	SCHALTHEBEL				
124	17	421850-4	STAUBSCHUTZ				
125	2	256206-0	STIFT 4				
126	19	345355-9	HALTERUNG				
127	1	265995-6	SCHRAUBE 4x18 [2]				
128	33	651131-4	SCHALTER C3D-15MS				
129	15	419045-1	SCHALTERABDECKUNG				
130	1	265995-6	SCHRAUBE 4x18 [2]				

